

AMSTRAD

DIRECT REMOTE CONTROL

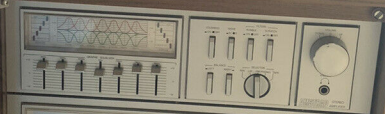

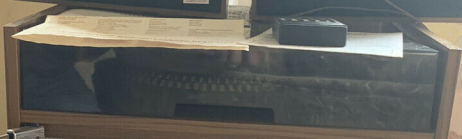

PIONEER
REMOTE CONTROL
TOWER SYSTEM
MODEL RT-2000

PLEASE READ THIS INSTRUCTION MANUAL BEFORE OPERATING THIS UNIT. PLEASE READ THIS INSTRUCTION MANUAL BEFORE OPERATING THIS UNIT. PLEASE READ THIS INSTRUCTION MANUAL BEFORE OPERATING THIS UNIT.



AMSTRAD

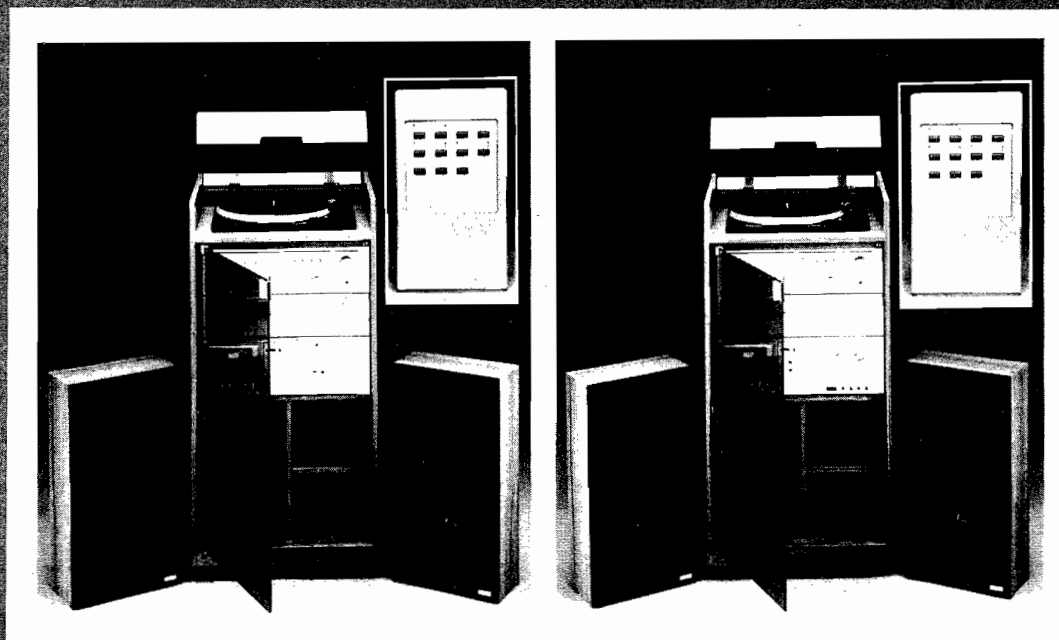

**TS80 / TS88
REMOTE CONTROL
TOWER SYSTEM
SERVICE MANUAL**

Price: £3.50

CONTENTS

General Routine Maintenance	2
Trouble Shooting Guide	3 & 4
Safety Test Procedure	5
Alignment Instructions	6
Cabinet Drawing and Parts List	7
Dial Cord Stringing	7
Cassette Mechanism and Parts List	8
Cassette Deck Alignment and Maintenance	9
Record Deck Drawing	10
Record Deck Parts List	11
Chassis Drawing	Middle Spread
Chassis Parts List	15
Main PCB	16 & 17
TS80 PCB's 2 - 5	18
TS88 PCB's 2 - 5	19
TS88 Tape 11 PCB 10	20
TS80 VU Meter PCB	21
Electrical Parts List	22 & 23
IC Pin Voltages	24
TS80 Circuit Diagram	Inside Back Cover
TS88 Circuit Diagram	Back Cover

AMPLIFIER SECTION	
Power Output	: 8 Watts RMS per channel into 4 ohms 32 watts Total Peak Music Power
Frequency Response	: 30Hz - 20KHz
Distortion	: 1% @ 1KHz Full Power 0.2% @ 1KHz Half Power
Graphic Equaliser	: 50Hz \pm 12dB 150Hz \pm 12dB 400Hz \pm 12dB 1KHz \pm 12dB 2.5KHz \pm 12dB 5KHz \pm 12dB 15KHz \pm 12dB
Filters	: Scratch -10dB @ 12KHz Rumble -10dB @ 40Hz Loudness +10dB @ 100Hz at max. vol. +6dB @ 10KHz -30dB
Signal to noise ratio	: Better than 55dB
TUNER SECTION	
FM Section	: 86.5 - 109MHz
MW Section	: 525 - 1650KHz
LW Section	: 140 - 280KHz
FM Sensitivity	: 5uV
FM Aerial Input	: 75ohms
CASSETTE SECTION	
Tape	: Cassette Type
Tape Speed	: 4.75cm per second
Tracks	: 2 Track Stereo
Wow and Flutter	: 0.15% WRMS
Distortion	: 1% @ 1KHz
Frequency Response	: 80Hz - 6KHz Standard Tape 60Hz - 8KHz Chrome Tape 60Hz - 10KHz Metal Tape
Noise Reduction	: -10dB @ 10KHz
Microphone Sensitivity	: 0.5mV - 600ohm
TURNTABLE	
Cartridge	: BSR P267
Transmission	: SC12M
Speed Control	: Belt Drive
Speed Control	: Electronic
REMOTE CONTROL UNIT	
Method of Transmission	: Infra Red-Pulse Position Modulation (PPM)
Volume up/down	: 0dB max -80dB min
Balance left/right	: -25dB attenuation per channel
Bass up/down	: \pm 10dB @ 100Hz
Treble up/down	: \pm 10dB @ 10KHz
Batteries	: 2 x 1.5V Leak Proof Type: Hitachi Maxell 200. Ever Ready R6PP or equivalent
DIMENSIONS AND WEIGHTS	
Main Unit	: 86cm (h) x 42cm (w) x 37cm (d)
Weight	: 25.0Kg
Speakers	: 49cm (h) x 27cm (w) x 13cm (d)
Weight	: 4Kg each
Mains Voltage	: 220 - 240V AC 50Hz

GENERAL ROUTINE MAINTENANCE

The following cleaning and maintenance should be carried out on a regular basis:

- 1) Always ensure that the stylus is clean and properly located in the cartridge.
- 2) We recommend regular cleaning of the heads and the pinch roller of the cassette deck and there are two ways of cleaning these parts:
 - i. using a commercial 'head cleaning' cassette as per the manufacturers instructions.
 - ii. using a cotton bud and methylated spirits.

To clean the relevant parts, you should press the 'eject' button so that the door is open. Ensure that the power is switched off, then press the 'play' key, which will raise both heads and the pinch roller which can then be cleaned with the cotton bud and methylated spirits.

When carrying out this operation, please be careful not to exert too much force on the cassette door as this may cause damage.

Whilst it is appreciated that using a head cleaning cassette is a more convenient method, this does tend to have a somewhat abrasive action and may increase the wear of the heads.

The cassette parts should be cleaned after approximately 25 hours use. However, it may be necessary to clean the cassette mechanism at specific instances as some cassettes themselves have a deposit of oxide dust which may be deposited on the relevant parts.

SAFETY TEST

PLEASE NOTE: When any work is completed on this unit, correct safety tests must be carried out to ensure continued electrical safety.

PLEASE NOTE: All parts shown with the part number prefix 'S' are Safety Items and must be replaced with similar items having an identical safety specification.

All of these items may be purchased direct from AMSTRAD CONSUMER ELECTRONICS PLC

GENERAL TROUBLE SHOOTING GUIDE

Symptoms	Fault	Cure
All functions on unit fail to operate.	Lack of power supply.	Check mains plug/mains fuse.
All functions fail to operate except record deck mechanism.	Fuse F501 blown. If fuse continues to blow, check for faulty mains transformer or meter bulbs. If fuse still continues to blow.	Replace. Check and replace as necessary. Circuit fault somewhere in area of power supply. Check and replace as necessary.
All functions fail to operate except record deck mechanism	Fuses 502 or 503 blown. If either fuse continues to blow. If fuse still continues to blow.	Replace as necessary. Check Bridge Rectifier or Power IC. General circuit fault. Check and repair as necessary.
VU LEDs not working.	Connecting plug between cassette section and main amplifier not locating properly.	Re-locate.
FM Tuner section selects no station but gives loud hiss.	Aerial not connected or aerial faulty. If there is no fault in the aerial.	Check aerial and replace or repair as necessary. General circuit fault in FM stage. Check and repair as necessary.
FM Tuner gives some sound but poor quality.	Poor aerial: 75ohm downlead broken. If aerial and leads are ok.	Repair/replace as necessary. General FM circuit fault. Check and repair as necessary.
FM works, but stereo light inoperative.	Decoder incorrectly aligned. LED faulty. Check decoder IC UPC1197C. If UPC1197C ok, fault is probably C203 (470pf Poly).	Re-align decoder (see alignment instructions). Replace. Check and replace as necessary. Check and replace as necessary.
AM radio section (MW/LW) inoperative or very weak.	Incorrect alignment. If alignment correct.	Check and re-align as necessary. Circuit fault. Repair as necessary. N.B. If replacing any components on the AM section, the set must be re-aligned.
Record deck fails to operate mechanically.	Wire disconnected from power supply. Motor fault. Belt disconnected.	Repair as necessary. Repair/replace as necessary.
Record deck operates mechanically but gives weak or distorted sound on both channels.	Stylus damaged. Stylus not located correctly in cartridge. Cartridge faulty.	Replace. Re-locate. Replace.
Record Deck operates mechanically but gives no sound on either or one channel.	Cartridge faulty. Wiring between cartridge and amplifier section disconnected.	Replace.
Record deck wow or flutter.	Belt slipping or stretched.	Clean, relocate or replace as necessary.
Record deck speed control inoperative.	Speed control IC faulty.	Check and replace as necessary.

Symptoms	Fault	Cure
Cassette deck mechanism not turning.	Connecting plug between cassette section and main amplifier not locating. Motor faulty. Drive belt not in position. Cassette jammed. General mechanical fault in cassette mechanism.	Re-locate. Check and replace as necessary. Re-position drive belt. Check for stretching of the belt and replace if necessary. Replace cassette. Check and repair as necessary.
Cassette speed varies (wow and flutter)	Dirty or worn pinch roller assembly. Drive belt in incorrect position. Motor faulty. General mechanical fault in cassette mechanism.	Clean or replace as necessary. Re-position drive belt or replace if worn or stretched. Check and replace as necessary. Check and repair as necessary.
Poor quality of recording or playback.	Dirty R/P Head. R/P Head picks up dust deposit almost constantly. R/P Head worn. Pin on connecting plug between cassette circuit and amplifier circuit not locating properly. General electronic fault on Cassette	Clean as necessary. Head requires demagnetisation. Replace. N.B. Please refer to cassette re-alignment instructions. Re-locate plug correctly. Check and repair as necessary.
When making new recordings, old recordings not erasing properly.	Faulty erase head. Wire disconnected from erase head. Faulty oscillator coil (L303).	Replace. Repair as necessary. Check and replace as necessary.
VU LEDs not working correctly.	Faulty leads from main amplifier and cassette. LEDs faulty.	Check and repair as necessary. Replace and re-adjust.
Severe hum on one or both channels with volume at minimum.	Output IC faulty.	Check and replace.
Hum on one or both channels at high volume only.	General circuit fault.	Check and repair as necessary.
One channel not working.	Check speaker and speaker leads by reversal.	Repair or replace as necessary.
One channel not working and blows fuse(s) 502 or 503.	Output IC faulty.	Check and replace as necessary.
Volume or tone controls crackling when operated.	Dirty or worn potentiometers.	Spray with switchclean or replace if necessary.
Output LEDs not working correctly.	Faulty LEDs. Fault on LED PCB.	Replace as necessary. Check and repair as necessary.
Sound through headphones but not speakers, one or both channels.	Headphone socket faulty. Lead disconnected between 'phone socket and speaker socket. Speaker socket faulty.	Check and replace. Check and repair as necessary. Check and replace as necessary.
One speaker gives distorted sound.	Faulty speaker. Check by reversal of speakers. If reversal of speakers demonstrates fault in amplifier section, faulty power IC. If fault condition persists, general amplifier fault.	Repair and replace as necessary. Check and replace. Check and repair as necessary.

SAFETY TEST PROCEDURE

These tests should be applied to the set after any work is carried out. These tests must be done to the set before the six screw blanking plates are fitted to the cabinet.

REQUIRED TEST EQUIPMENT

1. Flash Test Generator capable of testing at 2.2kV AC.
2. Megger tester rated at 500V DC.
3. Instrument capable of testing resistance down to 0.1ohm at 10amps.

TEST PROCEDURE

1. Stand on bench clear of all metal objects.
No leads should be connected to the unit.
Ensure that the on/off switch is in the ON position.
2. Set Flash test generator to 2.2kV AC.
Connect 1 pole to the live and neutral mains lead connected together and flash test the following points:
 - a) The headphone socket ring.
 - b) The rings of both microphone sockets.
 - c) The record deck transit screw.
 - d) All control knobs and buttons.
 - e) The underneath of the front panel, below the RECORD LEVEL knob.
 - f) The back panel.
3. Connect the megger tester to the live and neutral mains lead connected together and megger test the following points:
 - a) The headphone socket ring.
 - b) The rings of both microphone sockets.
 - c) The record deck transit screw.
 - d) All control knobs and buttons.
 - e) The underneath of the front panel, below the RECORD LEVEL knob.
 - f) The back panel.
4. Check that the earth lead continuity is below 0.5 ohms at 10amps between the mains earth lead core and the record deck transit screw.

CAUTION:

High voltages may be present on a faulty set and care should be taken to avoid electric shocks.

Certain components within this set are specific safety items and must be replaced with similar items which comply to the same safety specification.

All such parts may be obtained direct from AMSTRAD CONSUMER ELECTRONICS PLC

ALIGNMENT INSTRUCTIONS

Equipment required: VTVM; AM/FM Band SSG; Loop Antenna; AM/FM IF Genoscope; Non Metallic Trimming Tool; Dummy Load – 470K; Oscilloscope.

AM Alignment

Step	FUNCTION	SIGNAL IN	SIGNAL OUT	METHOD	REMARKS
1.	AM IF Alignment at 468KHz.	Inject signal at TP1 from AM IF SSG. Select 468KHz AS IF.	Connect G'scope at TP4.	Adjust IFT 103 and IFT 104 to get max signal output on 'scope.	1. Ensure set switched to MW band. - 2. Vol control max. Tone control at centre. 3. Sig. input optimum to avoid AGC action.
2.	REPEAT STEP 1 UNTIL NO FURTHER IMPROVEMENT IS OBSERVED.				
3.	MW Osc. Alignment at 525KHz.	Connect loop antenna to the ferrite rod. Inject signal from AM SSG at 525KHz.	Connect VTVM and O'scope across speaker output via 470K dummy load.	Adjust T101 to obtain max sig. output on the meter and 'scope.	1. Ensure set tuned to 525KHz. 2. Vol control max. Tone control at centre. 3. Sig. input optimum to avoid AGC action.
4.	MW Osc. Alignment at 1650KHz.	Connect loop ant. to the ferrite rod. Inject sig from AM SSG at 1650KHz.	Connect VTVM and O'scope across speaker output via 470K dummy load.	Adjust TC 105 to obtain max sig output on the meter.	1. Ensure set tuned to 1650KHz. 2. Vol control max. Tone control at centre. 3. Sig. input optimum to avoid AGC action.
5.	REPEAT STEPS 3 & 4 UNTIL NO FURTHER IMPROVEMENT OBTAINED				
6.	MW aerial alignment at 600KHz.	Connect loop ant. to the ferrite rod to inject sig from AM SSG at 600KHz.	Connect VTVM and O'scope across speaker output via 470K dummy load.	Adjust L104 to obtain max sig. output on the meter and scope.	1. Ensure set tuned to 600KHz. 2. Vol control max. Tone control at centre. 3. Sig. input optimum to avoid AGC action.
7.	MW aerial alignment at 1400KHz.	Connect loop ant. on the ferrite rod to inject sig from AM SSG at 1400KHz.	Connect VTVM and O'scope across speaker output via 470K dummy load.	Adjust TC 103 to obtain max sig output on the meter & scope.	1. Ensure set tuned to 1400KHz. 2. Vol control max. Tone control at centre. 3. Sig. input optimum to avoid AGC action.
8.	REPEAT STEPS 6 & 7 UNTIL NO FURTHER IMPROVEMENT				
9.	LW Osc and aerial alignment at 140KHz.	Connect loop ant to ferrite rod. Inject 140KHz from AM SSG.	Connect VTVM and O'scope across speaker output via 470K dummy load.	Adjust T102 and L104 to obtain max sig output on the meter and scope.	1. Ensure set switched to LW. 2. Set tuned to 140KHz 3. Vol control max. Tone control at centre. 4. Sig. input optimum to avoid AGC action.
10.	LW Osc alignment at 280KHz.	Connect loop ant to ferrite rod. Inject 280KHz from AM SSG.	Connect VTVM and O'scope across speaker output via 470K dummy load.	Adjust TC 106 and TC 104 to obtain max sig output on the meter and scope.	1. Ensure set switched to LW. 2. Vol control max. Tone control at centre. 3. Sig. input optimum to avoid AGC action.
11.	REPEAT STEPS 9 & 10 UNTIL NO FURTHER IMPROVEMENT				

FM ALIGNMENT

1.	FM IF alignment at 10.7MHz.	Inject 10.7MHz signal from FM IF SSG at TP2.	Connect O'scope to TP5.	Adjust T101 to obtain max output on the scope with a symmetrical 'S' curve centered at 10.7MHz.	1. Ensure set switched to FM. 2. Ensure stereo/mono sw switched to mono. 3. Sig. input optimum to avoid AGC action.
2.	FM IF alignment at 10.7MHz.	Inject 10.7MHz signal from FM IF SSG at TP2.	Connect O'scope to TP5.	Adjust T102 to obtain symmetrical 'S' curve.	1. Ensure set switched to FM. 2. Ensure stereo/mono sw switched to mono. 3. Sig. input optimum to avoid AGC action.
3.	REPEAT STEPS 1 & 2 UNTIL NO FURTHER IMPROVEMENT				
4.	FM Osc alignment at 86.5MHz.	Inject 86.5MHz signal from FM IF SSG at J101.	Connect scope & VTVM across dummy load.	Adjust L103 to obtain max output on the meter.	1. Ensure set tuned to 86.5MHz. 2. Ensure stereo/mono sw switched to mono. 3. Sig. input optimum to avoid AGC action.
5.	FM Osc alignment at 109.5MHz.	Inject 109.5MHz signal from FM IF SSG at J101.	Connect scope & VTVM across dummy load.	Adjust TC2 to obtain max output on the meter.	1. Ensure set tuned to 109.5MHz. 2. Ensure stereo/mono sw switched to mono. 3. Sig. input optimum to avoid AGC action.
6.	REPEAT STEPS 4 & 5 UNTIL NO FURTHER IMPROVEMENT				
7.	FM Osc tracking at 90MHz.	Inject 90MHz signal from FM IF SSG at J101.	Connect scope & VTVM across dummy load.	Adjust L102 to obtain max output on the meter.	Ensure set tuned to 90MHz, vol max, tone control to centre sig input optimum to avoid AGC action.
8.	FM Osc tracking at 106MHz.	Inject 106MHz signal from FM IF SSG at J101.	Connect scope & VTVM across dummy load.	Adjust TC1 to obtain max output on the meter.	Ensure set tuned to 106MHz, vol max, tone control to centre sig input optimum to avoid AGC action.
9.	REPEAT STEPS 7 & 8 UNTIL NO FURTHER IMPROVEMENT				
10.	FM MXP adjustment.	Set tuned to a strong stereo station.	Monitor stereo beacon.	Adjust VR201 to get the st. beacon on.	1. Ensure set switched to FM. 2. Ensure stereo/mono sw to stereo. FM alignment now complete.

Sym	Description	Part No.
1	Dust Cover	B8308
2	BSR P267 Turntable	S/83007
3	Hinge Cover	B9109
4	Cabinet	B3041
5	Castor Receptacle	B9003A
6	Castor	B9003B
7	Screw Cover	B1043
8	Magnet	B9005
13	Glass Door	B8310
14	Handle Pack	B9006A
15	Handle	B9006B
16	Hinge Grommet	B9110A
17	Hinge Screw	B9110B
18	Hinge Top	B9110
19	Hinge Pack	B9110C
20	Hinge Bottom	B9111
21	Cartridge BSR	83002A
	or	
21	Cartridge TETRAD	83007A
22	Stylus BSR	83002B
	or	
22	Stylus TETRAD	83007B

CABINET DRAWING & PARTS LIST

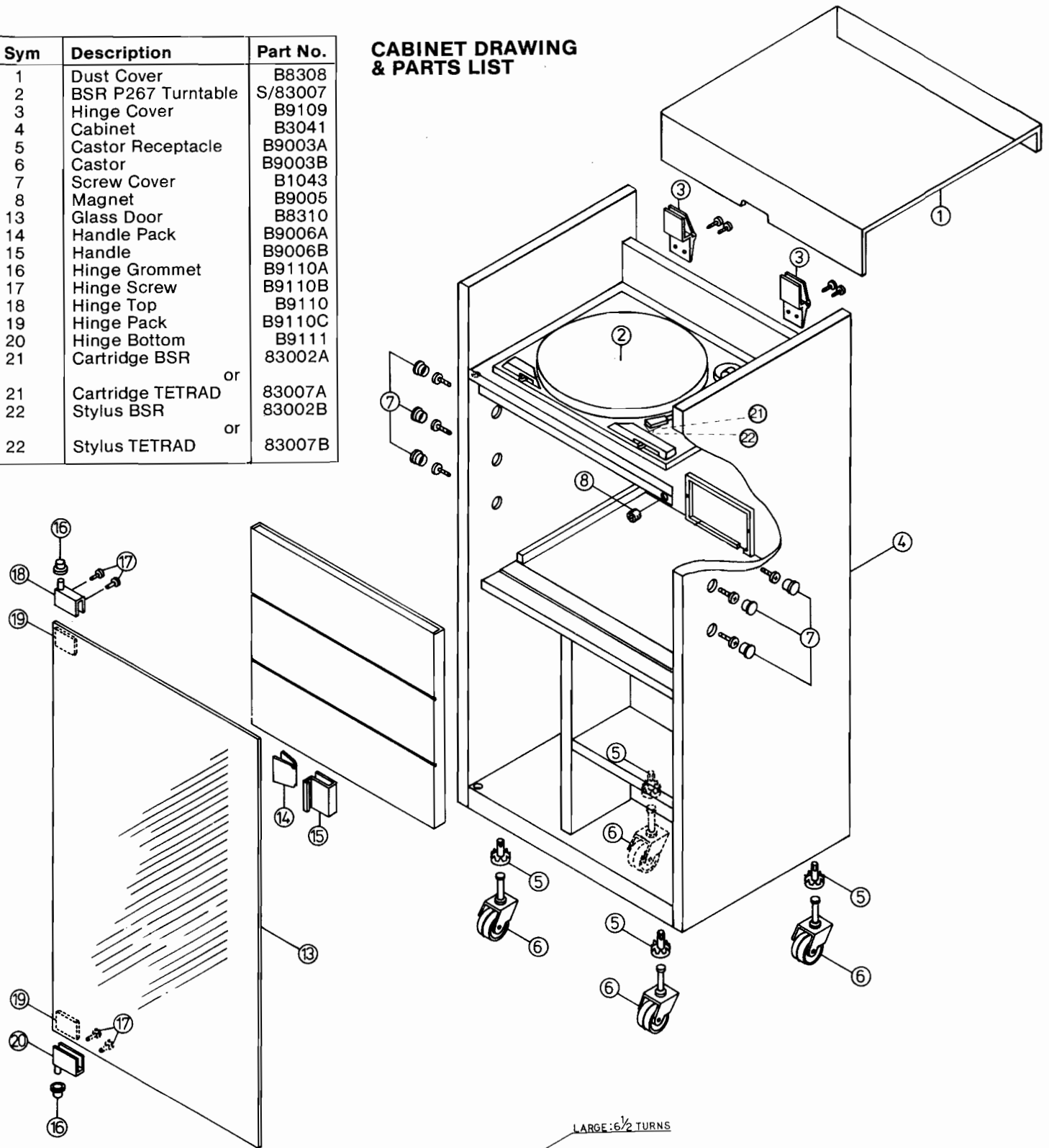

DIAL CORD STRINGING

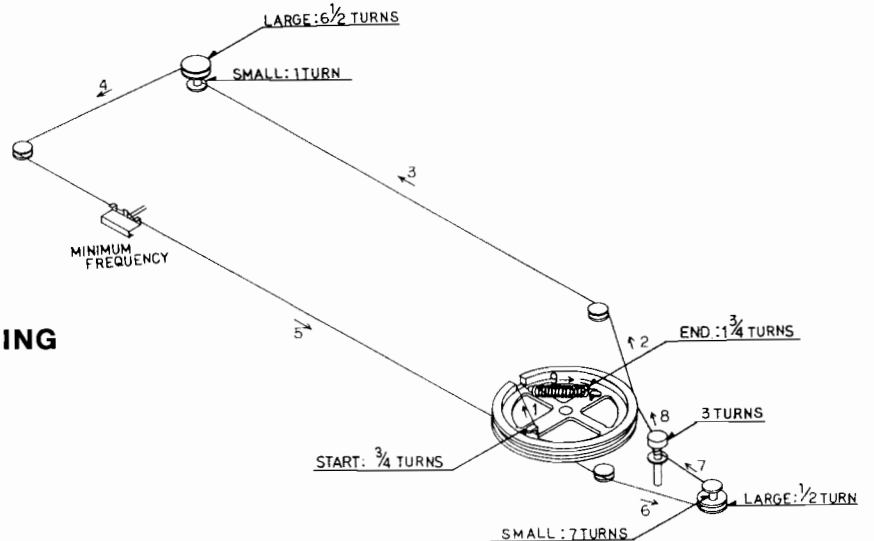

CASSETTE MECHANISM

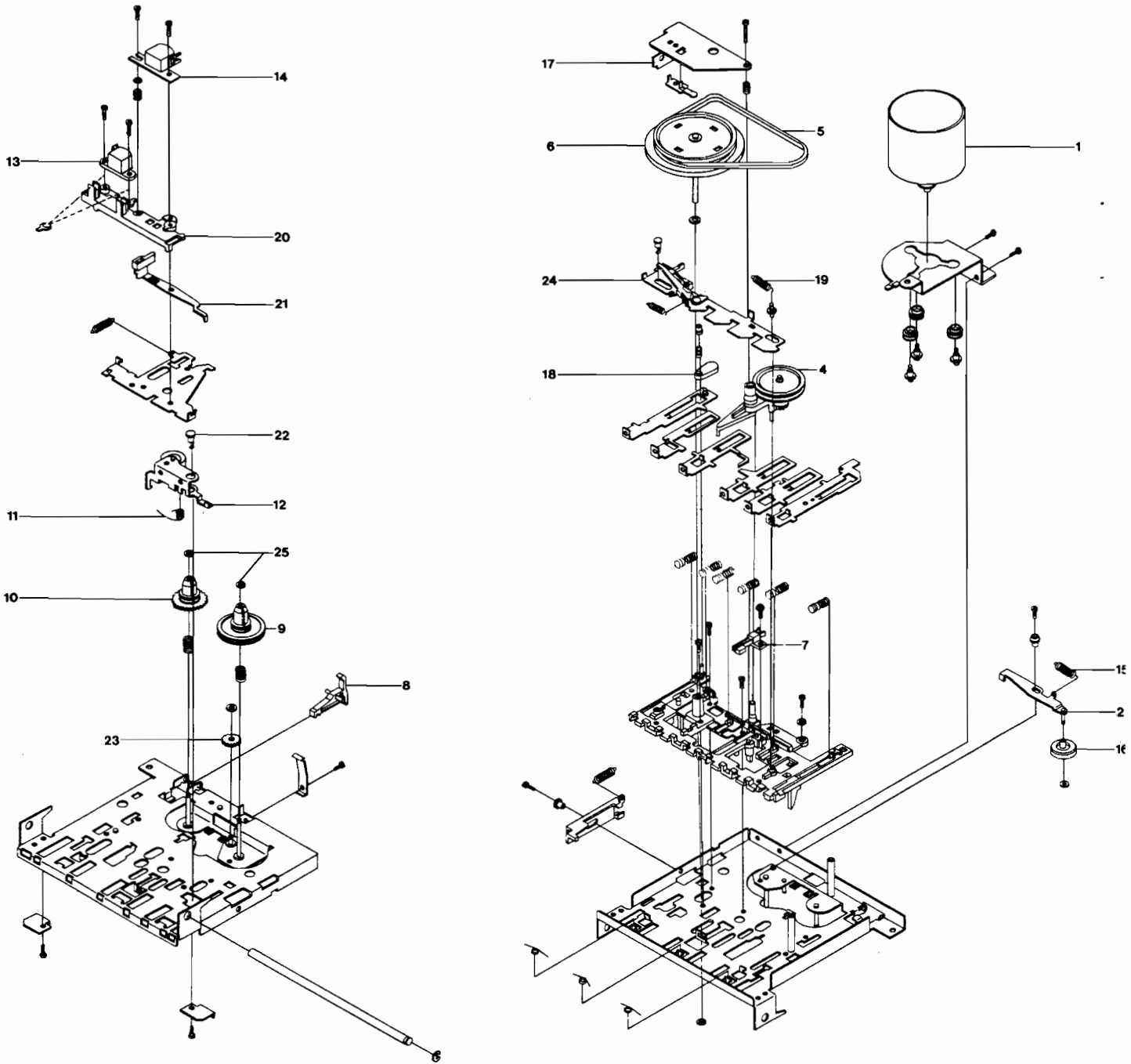

No.	Description	Part No.
1	Motor Assy	809151
2	R.W. Idler Arm Assy	809152
4	Idler Arm Assy	809154
5	Belt Main	809155
6	Flywheel	809156
7	Leaf Switch	809157
8	Record Safety Lever	809158
9	Take Up Spool Assy	809159
10	Rewind Spool Assy	809160
11	Pinch Roller Spring	809161
12	Pinch Roller	809162
13	Head Erase	700017
14	Head R.P.B.	700016

No.	Description	Part No.
15	Idler Spring	809165
16	Idler F.F./R.W.	809166
17	Flywheel Holder	809167
18	Pause Lock Lever	809168
19	Spring Locking Plate	809169
20	Head Base	809170
21	Auto Stop Arm Assy	809171
22	Stopper, Locking Plate	809172
23	F.F. Gear	809173
24	Locking Plate	809174
25	Poly Washer	809175

CASSETTE ALIGNMENT INSTRUCTIONS

Equipment required: Double Beam Oscilloscope; Frequency Counter; RMS Meter; Non-Metallic Trimming Tool; 6.8kHz Test Tape; 1kHz Test Tape.

Step	FUNCTION	SIGNAL IN	SIGNAL OUT	METHOD	REMARKS
1	Bias frequency adjustment.	Switch SW 301 to record.	Monitor 'scope or freq. counter from junction C328, C331.	Adjust L303 to give 625KHz.	Ensure the AFC switch is off.
2	Bias trap adjustment.	Switch SW 301 to record.	RMS Meter across R301/302 in turn.	Adjust L301/302 to get the same voltage at R301 & R302.	Voltage should not change if the AFC sw is on or off.
3	Bias level adjustment.	Switch SW 301 to record.	RMS Meter across R301/302 in turn.	Adjust VR 301/VR 302 to show 4.5mV.	Ensure AFC switch is off.
4	Head azimuth adjustment.	6.8KHz Test tape.	Double beam 'scope at speaker sockets.	Adjust azimuth screw for max amplitude on both channels ensuring both signals in phase.	Ensure set switched to tape.
5	Tape speed adjustment.	1KHz Test tape.	Frequency counter at speaker socket.	Adjust motor with non-metallic trimming tool for correct frequency.	Ensure set switched to tape.

CASSETTE DECK MECHANISM – GENERAL MAINTENANCE

Before attempting any specific fault-finding on the cassette mechanisms, it is recommended that the following checks and maintenance procedures be carried out.

1. **R/P HEAD** (Symbol 14)
Thoroughly clean the head and examine for signs of wear; replace if worn; de-magnetise.
2. **PINCH-ROLLER ASSEMBLY** (Symbol 12)
Thoroughly clean, check general condition. If rubber roller is in any way distorted, replace the assembly.
Check the tension of the Pinch-Roller Spring, the tension should be 40 to 60gm.
3. **MAIN BELT** (Symbol 5)
Ensure the belt is correctly located. Check that it is not stretched or worn and replace if necessary. In any event, remove the belt and clean with methylated spirits.
4. **TAKE-UP SPOOL ASSEMBLY** (Symbol 9)
Check the tension of this using a cassette torque meter. The correct reading should be 40gm per cm. A reading of between 30 and 50gm per cm may be regarded as within tolerance.
Should the reading fall below 30gm per cm, it must be adjusted to give the correct torque.
If it cannot be adjusted it should then be replaced.
5. **REWIND IDLER ASSEMBLY** (Symbol 2)
Check the tension with the cassette torque meter using the rewind function.
The torque should be 100gm per cm but a reading of between 80 and 110gm per cm may be considered within tolerance.
If the torque falls below 80gm per cm, it should be adjusted to give the correct reading.
If it will not adjust sufficiently, it should be replaced.
6. **MOTOR** (Symbol 1)
Ensure that the motor is securely mounted and that the motor rubbers are in good condition.
7. **FLY-WHEEL** (Symbol 6)
Check that the Fly-wheel spindle is not worn or bent and that it is securely seated in its bearing.
8. **INTERNAL MECHANISM**
After prolonged use, the internal mechanism will normally contain substantial deposits of oxide dust.
Ensure that these are thoroughly cleaned.

There are no places on either mechanism which require any oil or grease and the application of any such lubrication is likely to seriously harm the internal workings of the mechanism.

BSR P267 RECORD DECK AND PARTS LIST

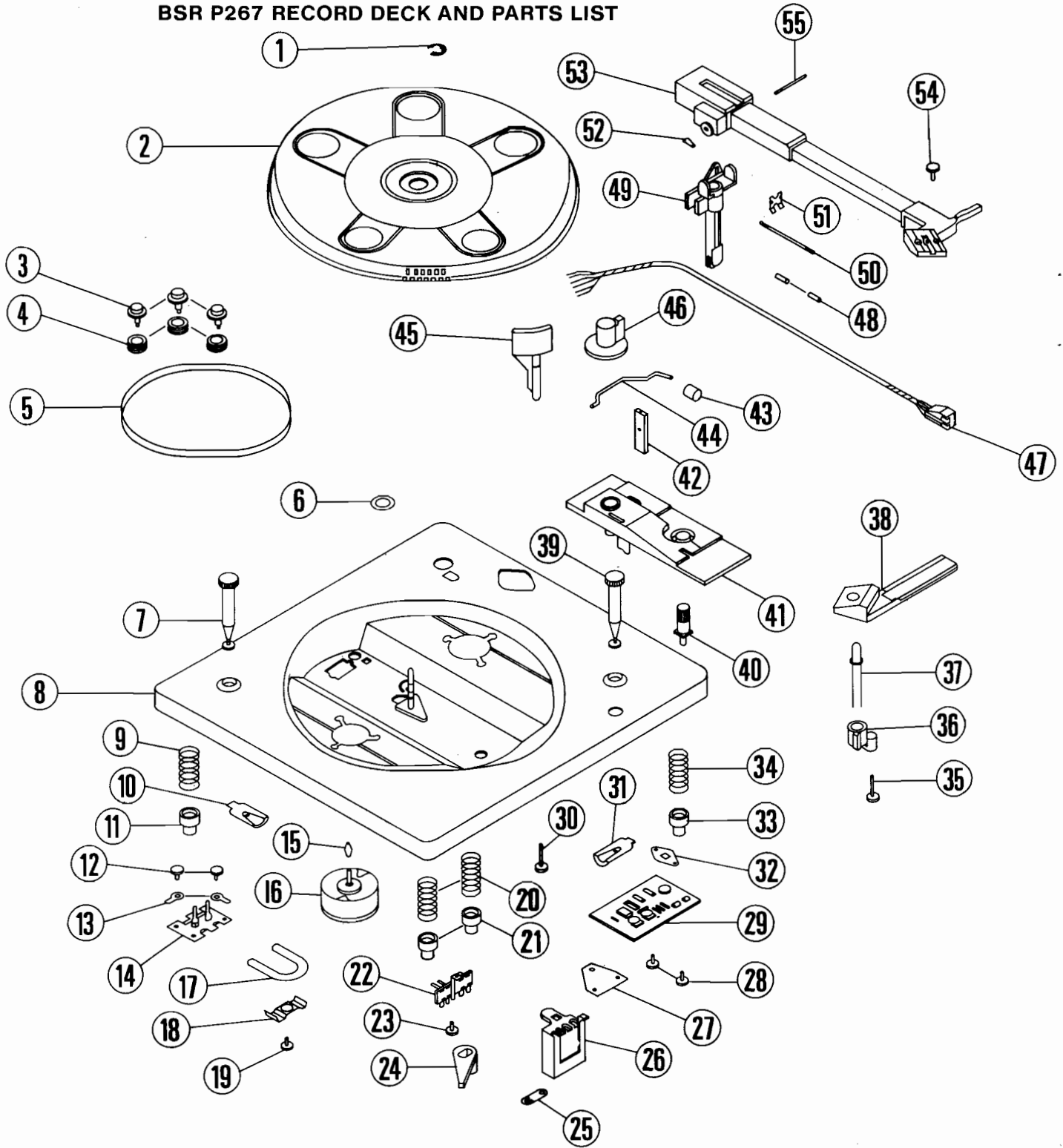

Item	Part No.	Description
1	A102110	Circlip
2	A117441	Turntable Assembly
3	A117382	Motor Mounting Screw (3 off)
4	A106210	Grommet (3 off)
5	A114446	Drive Belt
6	A114621	Thrust Washer
7	A104189	Transit Screw
8	B117437	Mainplate Welding & Riveting Assembly
9	A114759	Unit Mounting Spring
10	A102166	Retaining Clip
11	A106089	Spring Cup
12	A106510	Screw type B No.6 x 6.5 Rec. Pan Hd. (2 off)
13	A102126	Solder Tag (2 off)
14	A102616	Phono Socket
15	A116570	Drive Sleeve
16	B116574	D.C. Motor Requirements
17	A106513	76mm of 05 P.V.C. Sleeving
18	A102718	Cable Clamp
19	A114784	Screw type B.T.6-20 x 8 Rec. Pan Hd.
20	A114759	Unit Mounting Spring (2 off)
21	A106089	Spring Cup (2 off)
22	A106206	Tag Mounting Strip
23	A106510	Screw type B No.6 x 6.5 Rec. Pan Hd.
24	A117393	P.U. Hinge Retainer
25	A106749	4B.A. Tag Lockwasher
26	A111516	Molex Plug
27	A104865	Insulating Strip
28	A105267	Screw type B.T.4-24 x 8 Rec. Pan Hd. (2 off)

Item	Part No.	Description
29	A300126	On/Off Speed Control Board (B40)
30	A106512	Screw type B.T.4-24 x 16 Rec. Pan Hd.
31	A102166	Retaining Clip
32	A116564	Detent Spring
33	A106089	Spring Cup
34	A114759	Spring (Unit Mounting)
35	A106512	Screw type B.T.4-24 x 16 Rec. Pan Hd.
36	B117369	L.E.D. Mounting Clip
37	A325010	L.E.D. Requirements
38	A117464	Escutcheon Printing
39	A104189	Transit Screw
40	A116565	Knob Spindle
41	A117461	Control Escutcheon Printing
42	A117376	Pick-Up Rest
43	A114155	Cue Knob
44	A117378	Raising Arm
45	B117375	Raising Pad
46	B116562	Knob
47	A117439	P.U. Lead Assembly
48	A103373	Securing Rubber (2 off)
49	C117420	Pick-Up Hinge
50	A105237	P.U. Balance Spring
51	A105142	Spring Anchor
52	A103373	Securing Rubber
53	D117379	Pick-Up Arm
54	A117483	Screw type 'Plastite' 4-20 x 6.5 Rec. Pan Hd. (Black)
55	A117368	Pivot Pin

CHASSIS DRAWING

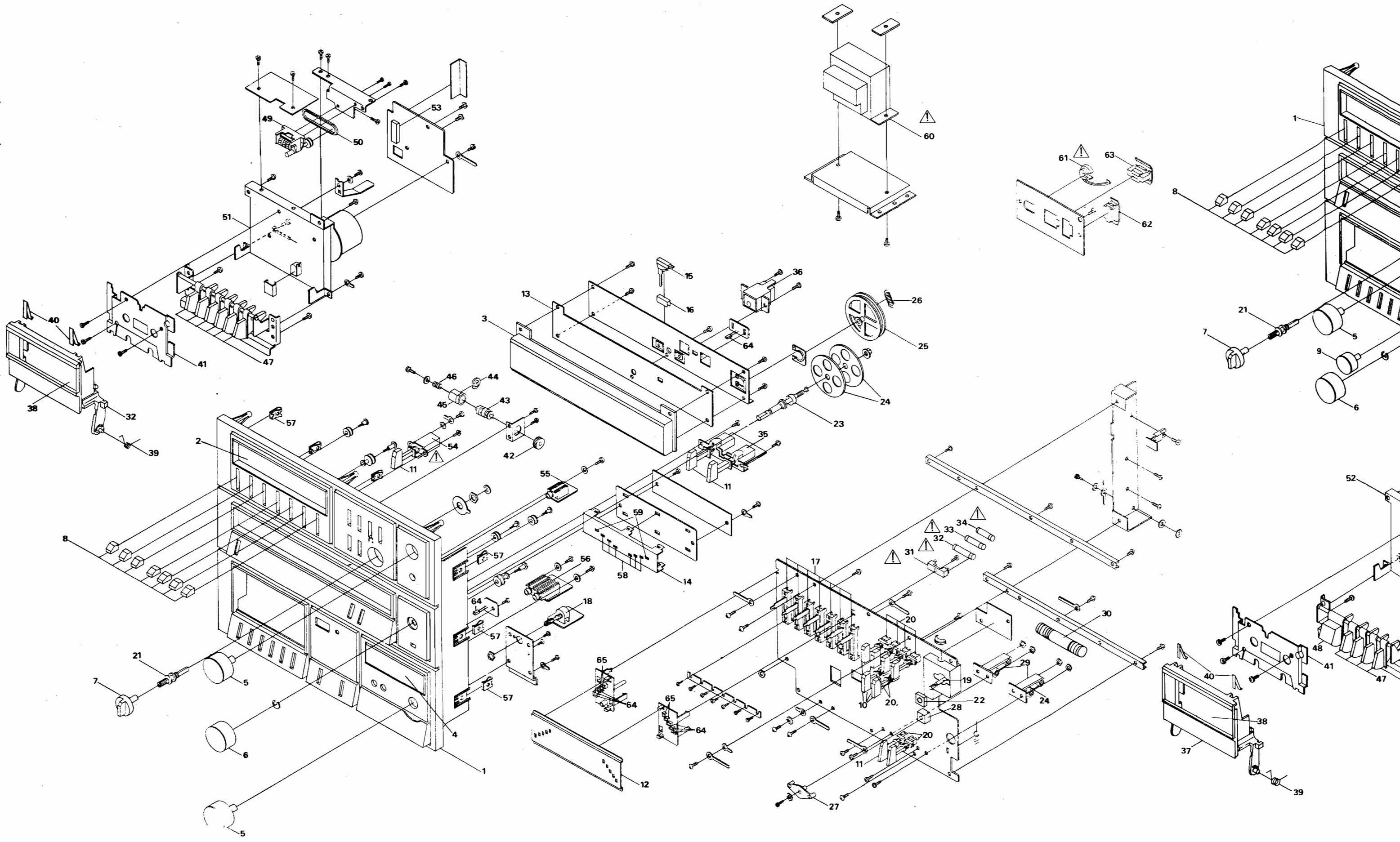

CHASSIS PARTS LIST TS80/88

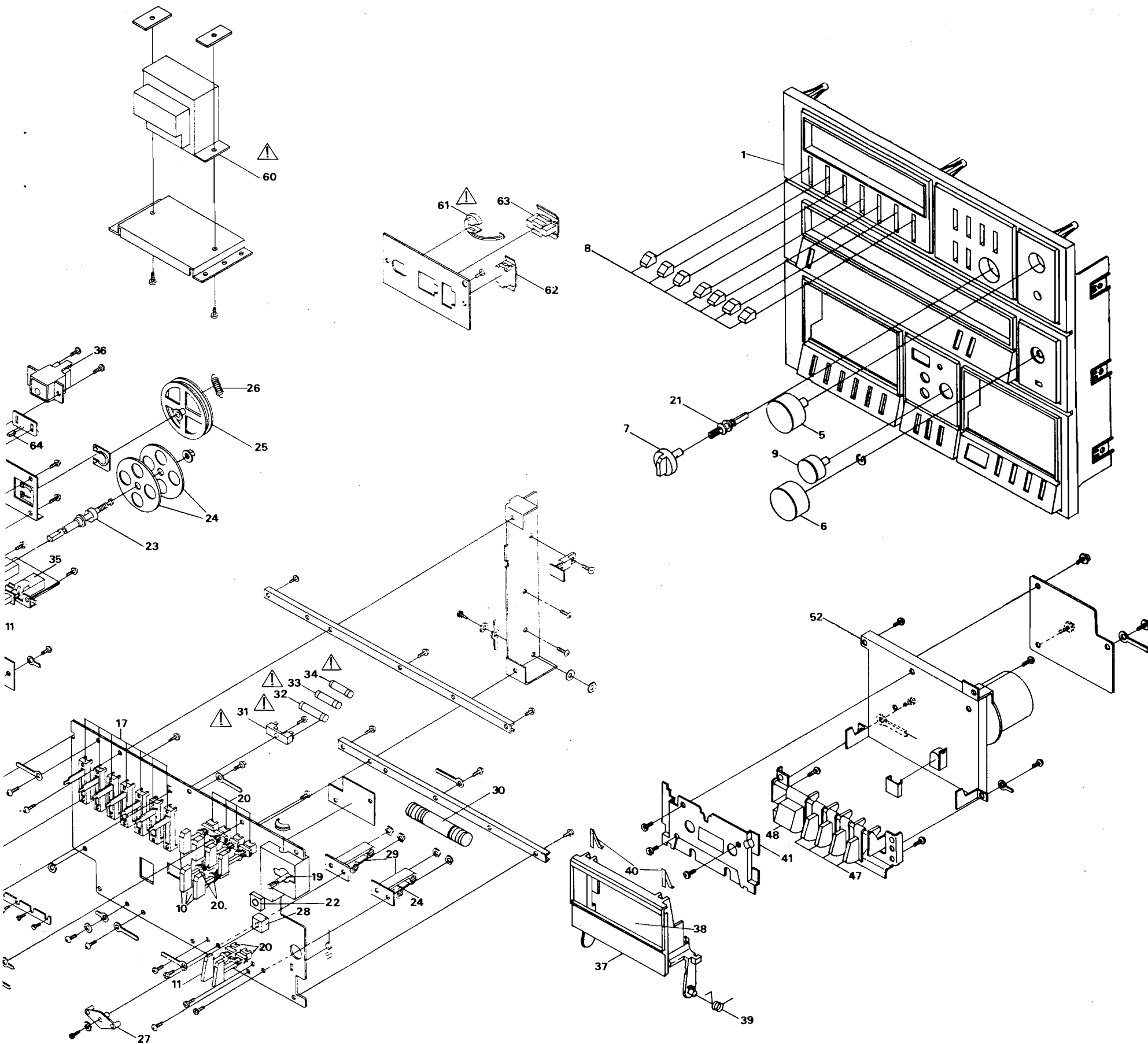

Sym	Description	TS-80 Part No.	TS-88 Part No.
1	Front Panel	800001	800801
2	Graphic Equaliser Lens	800002	800002
3	Dial Lens	800003	800003
4	Record Level Lens	800004	800004
5	Volume Knob	800005	800005
6	Tun. Record Level Knob	800006	800006
7	Select Knob	800007	800007
8	Graphic Tone Knob	800008	800008
9	Record Level Knob		800809
10	Push Button Knob (A)	800010	800010
11	Push Button Knob (B)	800011	800011
12	Graphic Inlay	800012	800812
13	Dial Scale	800013	800013
14	VU Meter Inlay	800014	800014
15	Pointer	800015	800015
16	Carriage Pointer	800016	800016
17	Slide Controls	800017	800017
18	Record Level Pot	300133	300133
19	Volume Switch	800019	800019
20	Push Switch	800020	800020
21	Selector Shaft	800021	800021
22	Selector Switch	800022	800022
23	Tuning Shaft	800023	800023
24	Tuning Flywheel	800024	800024
25	Tuning Drum	800025	800025
26	Tuning Spring	800026	800026
27	Tuning Coupling	800027	800027
28	PVC	800028	800028
29	Ferrite Rod Bracket	800029	800029
30	Ferrite Rod	800030	800030
31	Fuse Holder	S/88020	S/88020
32	T315mA F501 Fuse	S/88150	S/88150
33	T 2.5mA F502 Fuse	S/800033	S/800033
34	T500mA F503 Fuse	S/88005	S/88005
35	Tape Select Switch	800035	800835
36	PPM Sensor	800036	800036
37	Cassette Door	800037	800837
38	Cassette Door Lens	800038	800038
39	Eject Spring	800039	800039
40	Cassette Spring	809039	809039
41	Masking Plate	809040	809040
42	Gear	809042	809042
43	Shaft (Eject)	809043	809043
44	E Ring	809044	809044
45	Bearing Shaft	809045	809045
46	Spring Eject Shaft	809046	809046
47	Cassette Keys	800047	800047
48	Play Cassette Key		800848
49	Counter	809049	809049
50	Counter Belt	809050	809050
51	Complete Cassette Mechanism (A)	809051	809051
52	Complete Cassette Mechanism (B)		800052
53	Record Play Switch	800053	800053
54	ON/OFF Switch	S/35028	S/35028
55	Headphone Socket	800055	800055
56	Microphone Socket	809056	809056
57	Cabinet Securing Bracket	800057	800057
58	Red LED	400822	400822
59	Green LED	400823	400823
60	Transformer	S/800060	S/800060
61	Mains Lead Restraint	S/250011	S/250011
62	Aerial Socket	90042	90042
63	Speaker Socket	250012	250012
64	Red LED	800064	800064
65	Green LED	800065	800065
	Remote Control Module	800061	800061

Note: All parts shown with either the symbol or with an 'S' prefix on the part numbers, are safety critical items and must be replaced with items having an identical safety specification. All these items may be purchased direct from AMSTRAD CONSUMER ELECTRONICS PLC

MAIN PCB Bottom View

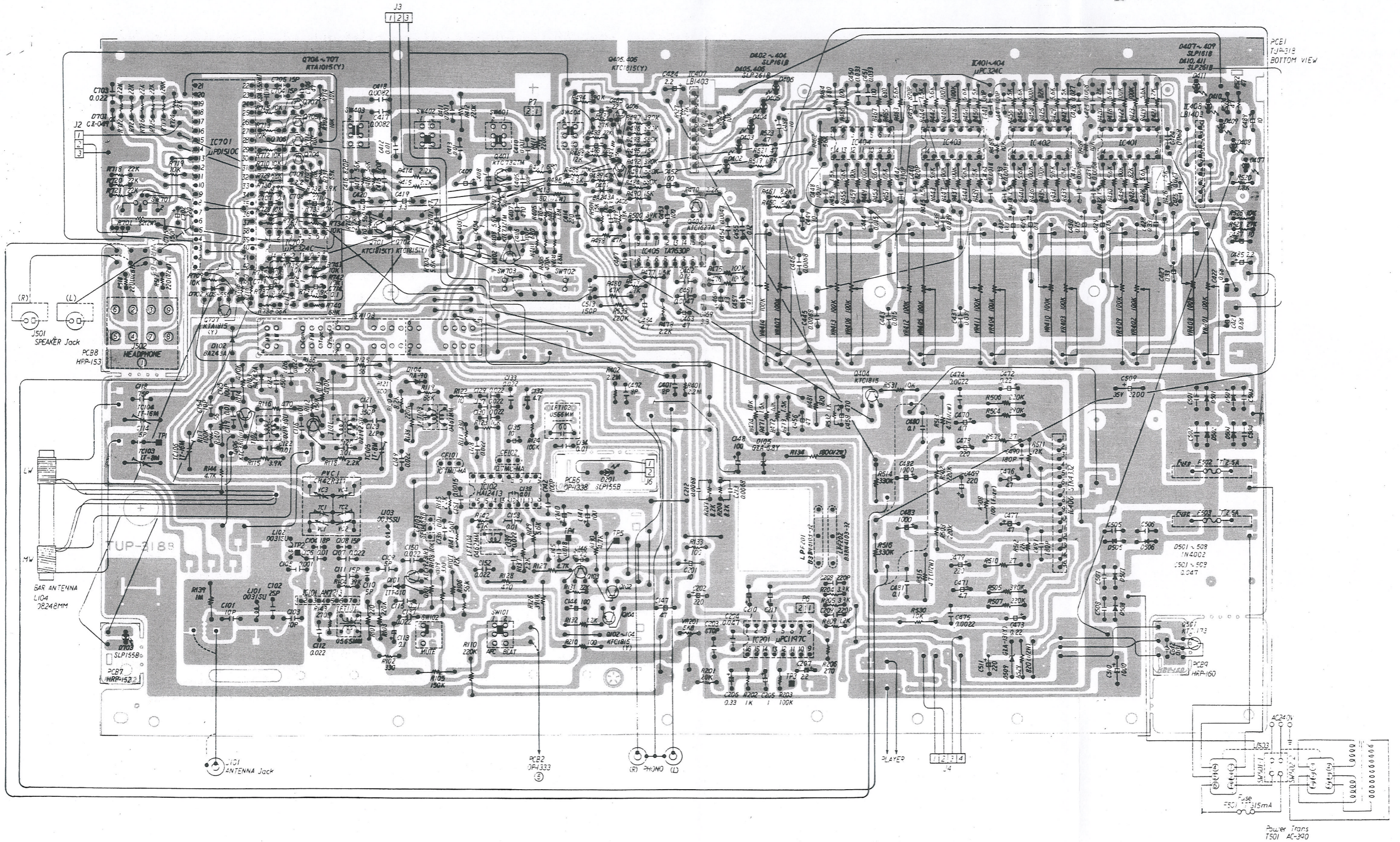

MAIN PCB Top View

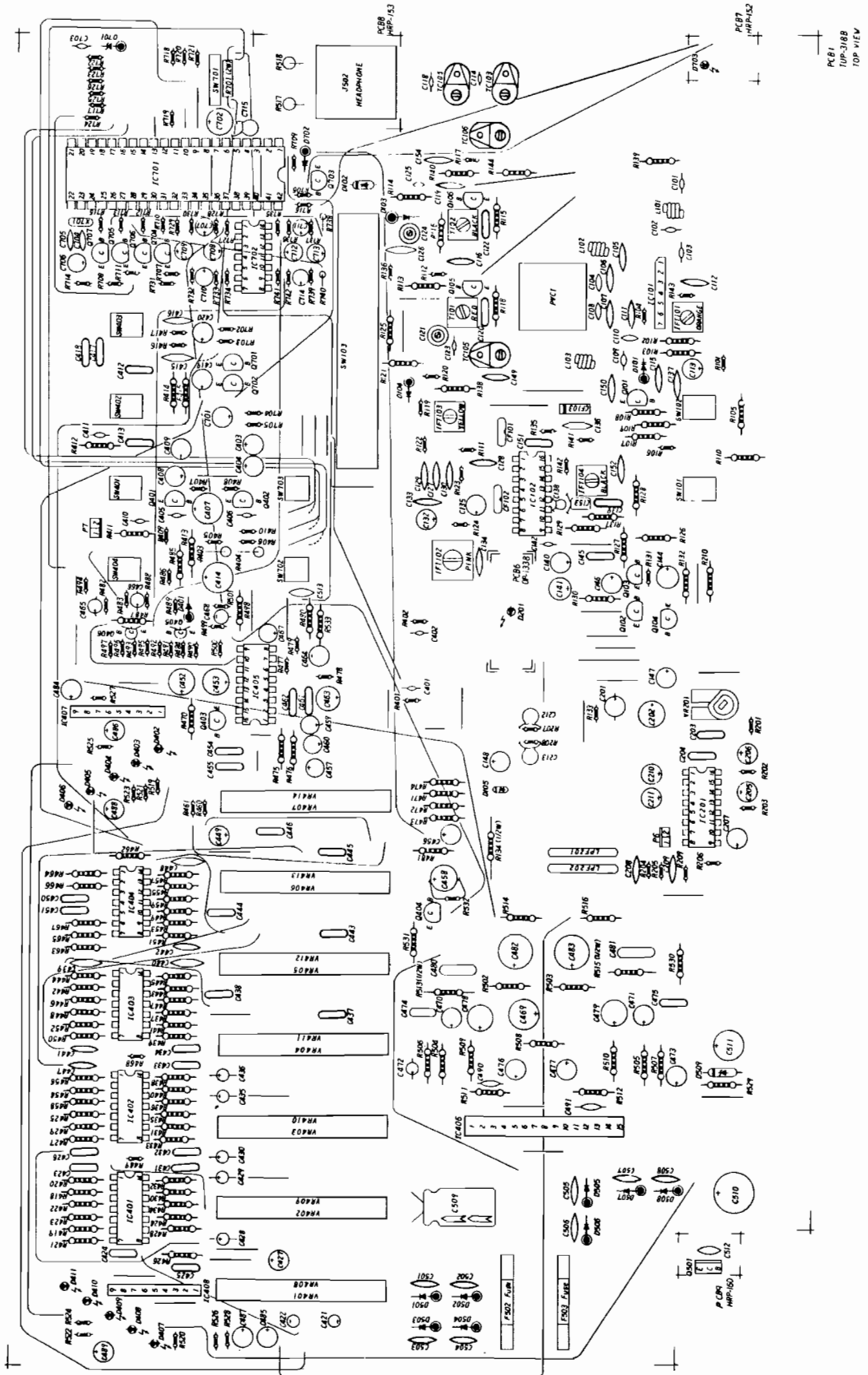

TS88 PCB's 2 - 5 Top View

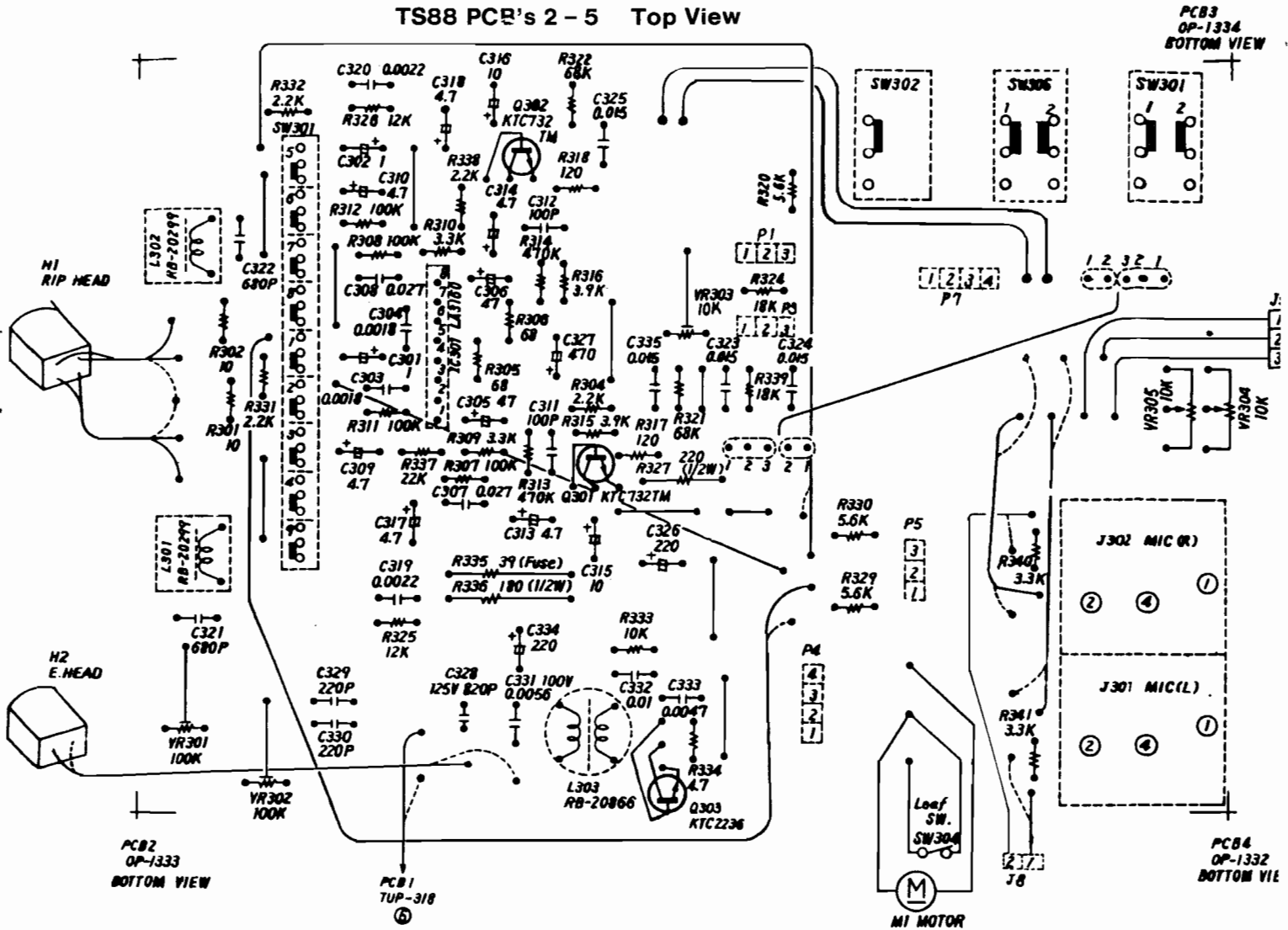

Bottom View

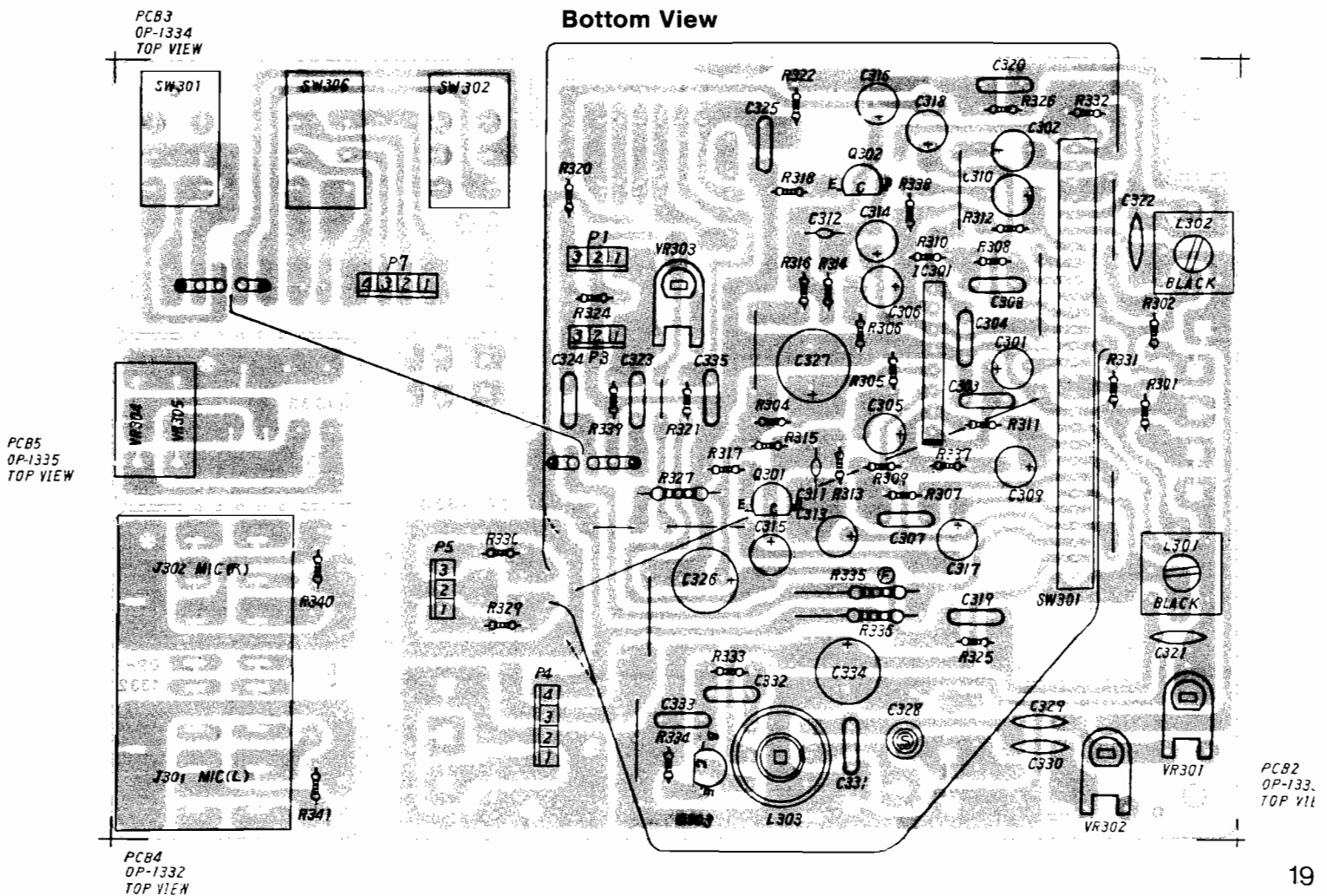

TS88 TAPE II PCB Top View

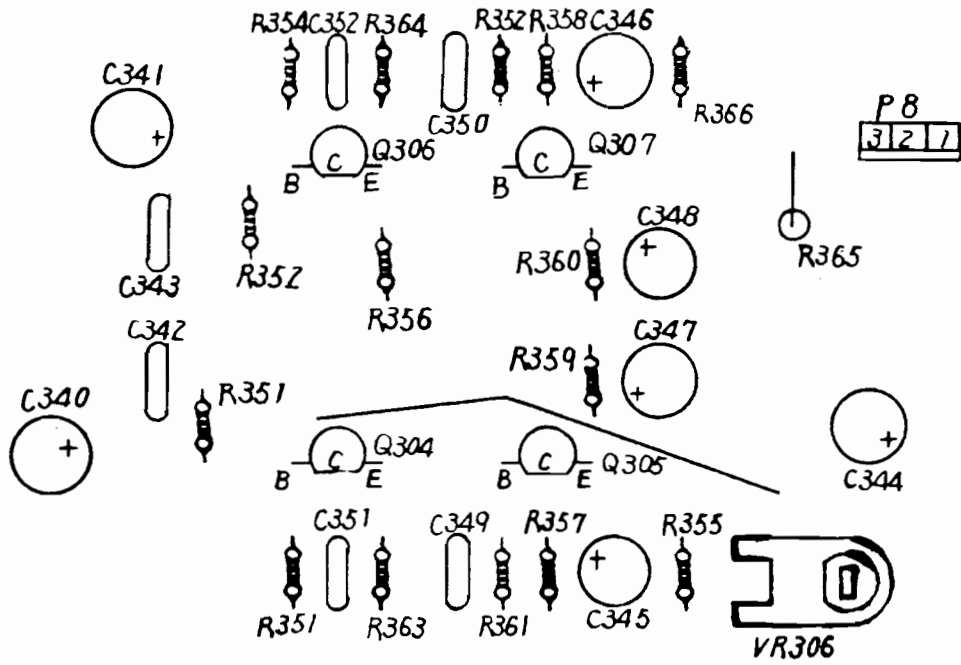

Bottom View

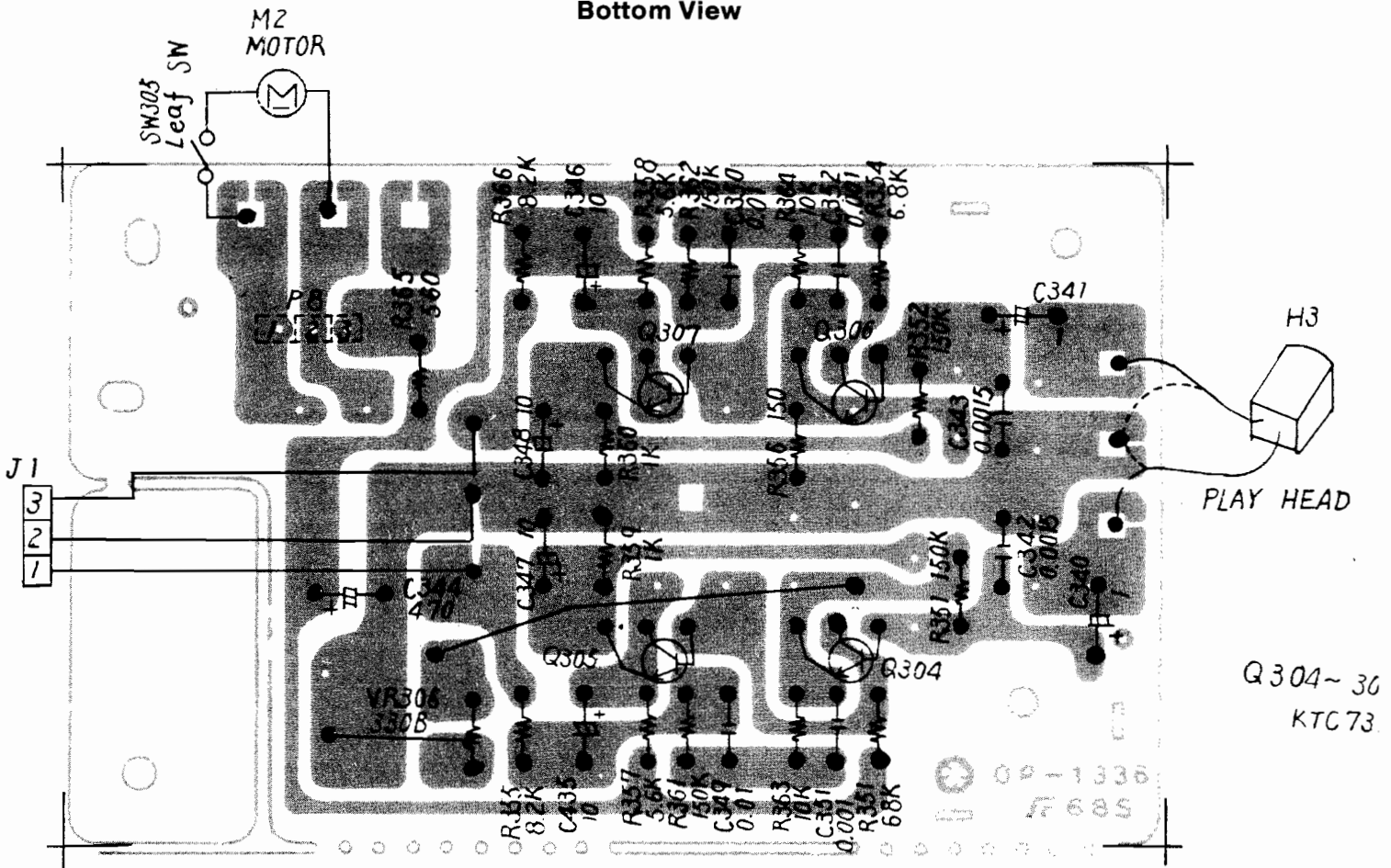

TS80 VU METER PCB Top View

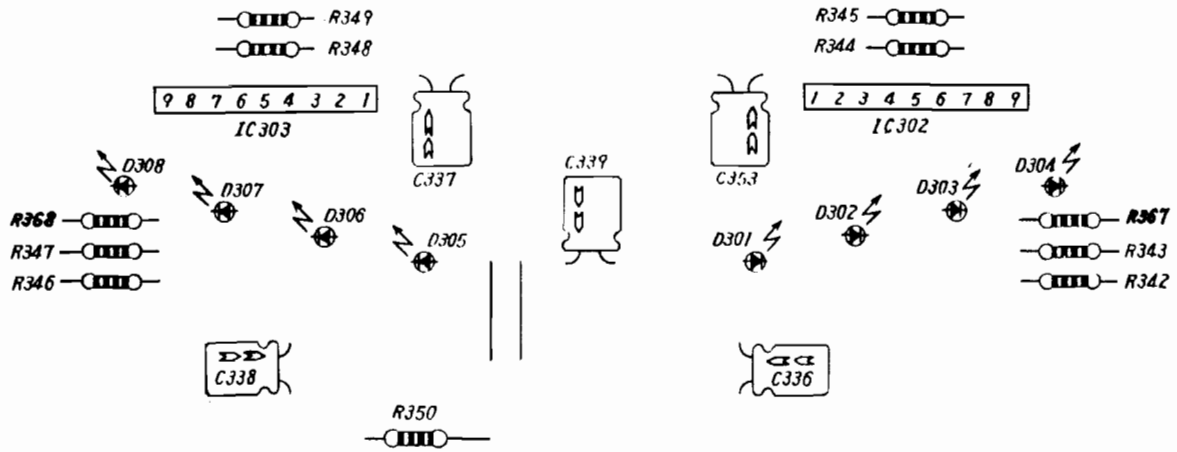

Bottom View

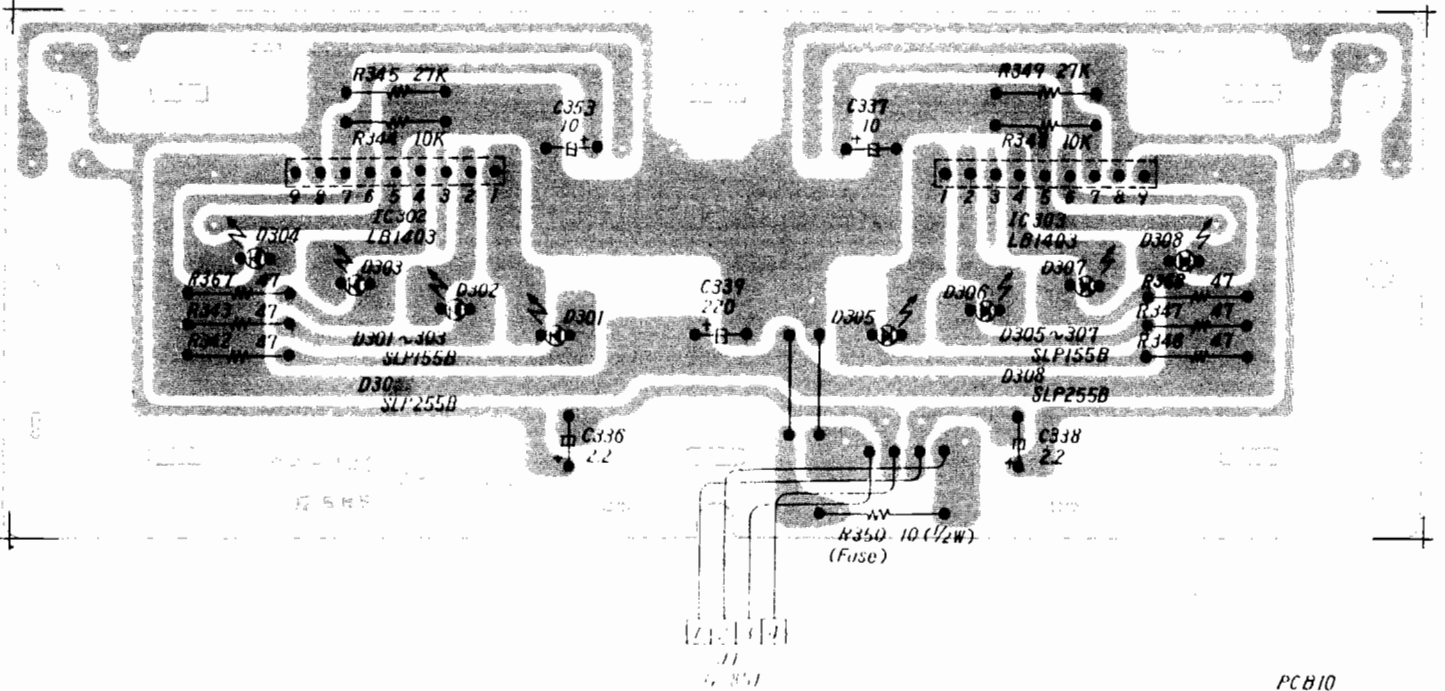

PCB10

ELECTRICAL PARTS LIST

Value	Circuit Reference	Part No.
Electrolytic Capacitors		
0.1uF/50V	C113	800210
0.22uF/50V	C472, 473	800211
1uF/50V	C140, 205, 210, 211, 301, 302, 403, 404, 408, 409, 467, 708, 712, 713	20062
2.2uF/50V	C207, 336, 338, 484, 485, 709	809246
3.3uF/50V	C419, 420, 459, 460, 468	20146
4.7uF/50V	C132, 309, 310, 313, 314, 317, 318, 454, 470, 471	20101
10uF/16V	C135, 201, 315, 316, 337, 353, 449, 486, 487, 488, 489	20024
22uF/10V	C465, 466	20025
47uF/10V	C147, 305, 306, 456, 457, 463, 476, 477, 701, 706	20053
100uF/16V	C141, 144, 148, 452, 453	20028
220uF/16V	C202, 326, 334, 339, 414, 478, 479, 511, 702	20029
220uF/35V	C409	20055
470uF/16V	C327, 407, 458	20044
1000uF/25V	C482, 483, 510	20118
2200uF/35V	C509	20119
Mylar Capacitors		
0.0015uF	C151	809231
0.0018uF	C303, 304, 433, 434	809232
0.0022uF	C319, 320, 474, 475	21002
0.0047uF	C333, 464, 461	21004
0.0056uF	C331	21015
0.0068uF	C212, 213, 323 - 325, 335, 431, 432, 445, 446	21024
0.0082uF	C417, 418	21025
0.01uF	C120, 122, 138, 153, 332, 412, 413	21006
0.015uF	C443, 444	809234
0.018uF	C145	809235
0.022uF	C139, 146	21007
0.027uF	C307, 308, 425, 426	21028
0.033uF	C450, 451	21012
0.039uF	C437, 438	21013
0.047uF	C204	21008
0.068uF	C423, 424	809236
0.1uF	C480, 481, 707, 710, 711, 714	21029
0.12uF	C455, 462	21019
Polystyrene Capacitors		
150pF	C124	800235
350pF	C121	800236
470pF	C203	800212
820pF (125V)	C328	22017
Alumi Solid Capacitors		
0.1uF/25V	C435, 436	800213
0.15uF/25V	C429, 430	809242
0.33uF/25V	C206, 427, 428	809243
0.68uF/25V	C421, 422	800214

Value	Circuit Reference	Part No.
Extra Capacitors on TS-88		
Ceramic Capacitors		
0.22uF	C128, 129	24019
Electrolytic Capacitors		
1uF/50V	C340, 341	20062
10uF/16V	C345, 348	20037
470uF/16V	C344	20044
Mylar Capacitors		
0.001uF	C351, 352	21001
0.0015uF	C342, 343	809231
0.01uF	C349, 350	21006
0.015uF	C323 - 325, 335, 443, 444	809234
ICs		
IC101	AN7213	809201
IC102	HA12413	809202
IC201	UPC1197C	800214
IC301	LA3160	901400
IC302, 303, 407, 408	LB1403	809207
IC401 - 404, 702	UPC3246	800215
IC405	TA7630P	800216
IC406	STK4332	800217
IC701	UPC1510C	800218
Diodes		
D101	ITT410 Varicap Diode	920117
D102, 103, 401	BA243A	800219
D104	OA90	800220
D105	6ZA 6.8Y Zener	809219
D501 - 508	IN4002 P. Rectifier	15008
D509	G. 13Y Zener	15005
D701	CZ. 049 Zener	800221
D702	KDS1555	800222
Transistors		
Q101	KTC1923 BF595	50014
Q102 - 104, 404 - 406, 701 - 703		50014
Q105, 106	KTC380 BF595	50014
Q301, 302, 401, 402	KTC732 BC237	50016
Q303	KTC2236 BD370	50017
Q403	KTC 1627 BC237	50016
Q501	KTC1173/2SD313/2N5496	50005
Q704 - 707	KTC1015 BF594	50041
Coils Ant Transformers		
L101, 102	0031SU FM Ant Coil	300616
	0031SU FM RF Coil	
L103	0035SU FM Osc Coil	300617
L301, 302	RB-20299 Trap Coil	300619
L303	RB20866 Bias Osc Coil	300620
T101	02192SU MW Osc Coil	300621
T102	02193SU LW Osc Coil	800223
IFT101	0565MM FM IFT	300623
IFT102	0566MM FM IFT	300624
IFT103	0461MM AM IFT	300625
IFT104	0462MM AM IFT	300626
Miscellaneous		
PVC 1	CH 42 R311 PVC	800224
CF101, 102	10.7MHz Ceramic Filter	993034
CF103	468KHz Ceramic Filter	800225
TC103, 105	8pF Trimmer	800226
TC104, 106	16pF Trimmer	800227
LPF201, 202	B3BN4103-32 Low Pass Filter	800228
X701	CSA 3.58MT Ceramic Osc	800229

Value	Circuit Reference	Part No.
Resistors (all 1/4W / 5%)		
4ohm7	R334, 513, 515	10004
10ohm	R122, 301, 302	10008
27ohm	R509, 510	10017
47ohm	R342, 343, 346, 347, 367, 368, 521 - 524	10020
56ohm	R125, 140	809247
68ohm	R305, 306	10028
100ohm	R121, 133, 210, 466, 467	10032
120ohm	R317, 318	10034
220ohm	R101, 502, 503, 506, 507, 517, 518	10040
270ohm	R143, 206	10042
330ohm	R102, 109, 111	10044
470ohm	R116, 128	10048
560ohm	R141, 703, 716	10050
680ohm	R409, 410, 464, 465	10052
820ohm	R481	10054
1K	R202, 532	10061
1K2	R132, 209, 420, 421	10063
1K5	R426, 427, 432, 433, 438, 439, 444, 445, 450, 451, 456, 457, 477	10065
1K8	R519, 520	10067
2K2	R118, 135, 137, 304, 331, 332, 414, 415, 470, 478, 702	10069
3K3	R204, 205, 309, 310, 340, 341	10073
3K9	R115, 315, 316, 730, 732, 737, 739	10075
4K7	R127, 130, 144, 705	10077
5K6	R129, 329, 330, 407, 408, 416 - 419, 428 - 431, 440 - 443, 452 - 455, 462, 463, 704	10079
8K2	R120, 207, 208, 460, 461	10083
10K	R108, 123, 333, 344, 348, 468, 469, 472, 474, 525, 526, 530, 531, 707 - 715, 719, 727, 728, 733, 735, 736, 742, 734, 741	10085
12K	R107, 325, 326, 488, 511, 512	10087
15K	R320, 487, 490, 495, 501	10089
18K	R324, 339, 499	10091
20K	R201	10092
22K	R131, 337, 338, 483, 706, 718, 720 - 726	10093
27K	R345, 349, 479, 482, 527, 528	10095
39K	R104, 500	10099
47K	R142, 480, 489, 498	10101
56K	R106, 136	10103
68K	R119, 321, 322, 738, 740, 729, 731	10105
82K	R424, 425	10107
100K	R117, 124, 203, 307, 308, 311, 312, 422, 423, 434 - 437, 446 - 449, 458, 459, 475, 476	10109
120K	R717	10111
150K	R105, 112	10113
220K	R103, 110, 138, 411, 412, 533	10117
330K	R514, 516	10121
390K	R126, 492, 494, 497, 504, 505	10123
470K	R113, 114, 313, 314, 405, 406	10125
680K	R484, 491, 493, 496	10129
1M	R139	10147
1M8	R403, 404	10150
2M2	R401, 402	10151

IC VOLTAGES FOR REMOTE MODULE

1	0	9	0
2	0	10	2.7V DC
3	0V DC	11	3.3V DC
4	0V DC	12	3.3V DC
5	0V DC	13	3.3V DC
6	3.3V DC	14	3.3V DC
7	2.3V DC	15	3.3V DC
8	0.3V DC	16	2.75V DC

Note: All parts shown with either the symbol  or with an 'S' prefix on the part numbers; are safety critical items and must be replaced with items having an identical safety specification. All these items may be purchased direct from AMSTRAD CONSUMER ELECTRONICS PLC

Value	Circuit Reference	Part No.
Extra components on TS-88		
Resistors		
150ohm	R356	10036
560ohm	R365	10050
1K	R359, 360	10061
1K5	R471, 473	10065
5K6	R320, 357, 358, 418	10079
6K8	R485	10081
8K2	R355, 366	10083
10K	R363, 364, 486	10085
56K	R416, 417	10103
68K	R353, 354	10105
150K	R351, 352, 361, 362	10113
Safety Resistors		
10ohm 1/2W	R350	S/800200
39ohm 1/2W(f)	R335	S/800201
82ohm 2W	R701	S/800202
100ohm 1/2W(f)	R508	S/809224
180ohm 1/2W	R134, 336, 413	S/800203
220ohm 1/2W	R327	S/800204
820ohm 1/2W	R529	S/800205
Extra on TS-88		
4ohm7 1/2W	R513, 515	S/800206
220ohm 1/2W	R517, 518	S/800207
* (f) = fusible resistor		
Capacitors		
Ceramic Capacitors		
5pf	C109, 110, 114	400104
8pf	C401, 402	400105
10pf	C101, 103, 154	24001
15pf	C108, 111, 704, 705	400106
18pf	C104	610122
22pf	C123	24021
25pf	C102	24028
75pf	C118	800208
100pf	C125, 142, 311, 312, 405, 406, 447, 448	24016
150pf	C513, 715	24017
180pf	C490, 491	400107
220pf	C208, 209, 329, 330	400107
220pf	C208, 209, 329, 330	400107
330pf	C441, 442	24003
680pf	C321, 322	809239
820pf	C415, 416, 439, 440	800209
0.001uF	C105, 410, 411	24027
0.01uF	C106, 115, 116, 119, 134, 136, 512	24011
0.022uF	C107, 112, 126, 127, 130, 133, 137, 149, 150, 153, 703	24013
0.047uF	C501-508	24015

PARTS LIST FOR REMOTE CONTROL MODULE

Value	Circuit Reference	Part No.
Resistors		
1ohm	R603	809252
56ohm	R602	809247
3K3	R601	10073
22K	R604	10093
Capacitors		
100pF	C602, 603	21001
100uF/6.3V	C601	20028
Transistors		
2SD 736 or 2SD 637	Q601	800230
2SD 638 or 2SD 639	Q601	800231
IC		
IC601	UPC 1913C	800232
Diodes		
MA 165 or MA 150	D601 - 603	800233
SE 303A or LN.66	D604, 605	800234

IC & TRANSISTOR VOLTAGES

IC101 - AN7213

1	4.3V DC	5	4.9V DC
2	5.0V DC	6	5.0V DC
3	5.0V DC	7	4.3V DC
4	0V DC		

IC102 - HA12413

	FM	AM		FM	AM
1	1.8V DC	1.2V DC	9	2.2V DC	2.4V DC
2	1.8V DC	1.2V DC	10	2.2V DC	2.5V DC
3	5.8V DC	0V DC	11	5.9V DC	5.9V DC
4	1.8V DC	2.0V DC	12	0.4V DC	0.7V DC
5	0V DC	0V DC	13	0V DC	0V DC
6	1.3V DC	1.3V DC	14	2.0V DC	2.1V DC
7	2.0V DC	2.1V DC	15	0.2V DC	0.4V DC
8	2.0V DC	2.0V DC	16	0.9V DC	0.9V DC

IC201 - UPC 1197C

1	4.8V DC	0V DC	9	0V DC	0V DC
2	1.5V DC	0V DC	10	1.6V DC	0V DC
3	2.0V DC	0V DC	11	1.6V DC	0V DC
4	1.5V DC	0V DC	12	1.3V DC	0V DC
5	1.6V DC	0V DC	13	1.6V DC	0V DC
6	11.9V DC	11.9V DC	14	1.6V DC	0V DC
7	0V DC	0V DC	15	1.6V DC	0V DC
8	0.3V DC	0V DC	16	1.6V DC	0V DC

IC301 - LA 3160

1	1.3V DC	5	0V DC
2	0.8V DC	6	3.0V DC
3	2.3V DC	7	0.8V DC
4	5.4V DC	8	1.3V DC

IC302, 302 - LB1403

1	11.3V DC	6	11.2V DC
2	11.3V DC	7	0V DC
3	1.3V DC	8	0V DC
4	11.3V DC	9	12.8V DC
5	0V DC		

IC401 - 404 - UPC 324C

1	0V DC	8	6.7V DC
2	6.7V DC	9	6.7V DC
3	6.7V DC	10	6.6V DC
4	13.3V DC	11	0V DC
5	6.7V DC	12	6.6V DC
6	6.7V DC	13	6.7V DC
7	6.7V DC	14	6.7V DC

IC405 - TA 7630P

1	0V DC	9	2.2V DC
2	6.1V DC	10	2.2V DC
3	6.2V DC	11	6.2V DC
4	6.2V DC	12	12.4V DC
5	4.5V DC	13	6.3V DC
6	6.2V DC	14	6.3V DC
7	2.1V DC	15	6.1V DC
8	1.4V DC	16	6.2V DC

IC406 - STK 4332

1	7.1V DC	9	8.5V DC
2	6.8V DC	10	3.6V DC
3	0V DC	11	14.9V DC
4	0V DC	12	0V DC
5	14.9V DC	13	0V DC
6	3.7V DC	14	6.9V DC
7	9.5V DC	15	7.3V DC
8	0V DC		

IC407, 408 - LB 1403

1	11.5V DC	6	11.4V DC
2	11.4V DC	7	0V DC
3	0V DC	8	0V DC
4	11.4V DC	9	12.9V DC
5	0V DC		

IC701 - UPD 1510C

1	0V DC	22	2.0V DC
2	0V DC	23	1.4V DC
3	0V DC	24	5.0V DC
4	0V DC	25	2.6V DC
5	3.9V DC	26	2.5V DC
6	3.6V DC	27	2.6V DC
7	3.9V DC	28	2.5V DC
8	3.9V DC	29	2.6V DC
9	0V DC	30	2.5V DC
10	0.7V DC	31	3.9V DC
11	5.0V DC	32	0V DC
12	0V DC	33	3.9V DC
13	0V DC	34	0V DC
14	0V DC	35	0V DC
15	0V DC	36	0V DC
16	5.0V DC	37	0V DC
17	5.0V DC	38	0V DC
18	5.0V DC	39	0V DC
19	5.0V DC	40	0V DC
20	0V DC	41	5.0V DC
21	0V DC	42	5.0V DC

TRANSISTOR VOLTAGES

Q. No.	E	B	C
Q101	0.4V DC	1.0V DC	5.9V DC
Q102	2.0V DC	2.7V DC	2.0V DC
Q103	0V DC	0V DC	2.7V DC
Q104	0V DC	0.2V DC	6.0V DC
Q105	0.6V DC	1.2V DC	6.9V DC
Q106	0.5V DC	1.0V DC	6.8V DC
Q301	0.3V DC	0.9V DC	3.1V DC
Q302	0.3V DC	0.9V DC	3.3V DC
Q303	0.2V DC	0.7V DC	5.2V DC
Q401	0.9V DC	1.5V DC	5.6V DC
Q402	0.9V DC	1.5V DC	5.2V DC
Q403	12.3V DC	13.1V DC	13.3V DC
Q404	0V DC	0V DC	2.2V DC
Q405	2.1V DC	2.7V DC	2.2V DC
Q406	2.1V DC	2.7V DC	2.2V DC
Q501	13.4V DC	14.0V DC	9.5V DC
Q701	0V DC	0.7V DC	0V DC
Q702	0V DC	0V DC	5.1V DC
Q703	0V DC	0V DC	3.6V DC
Q704	5.1V DC	4.9V DC	1.2V DC
Q705	5.1V DC	4.7V DC	2.5V DC
Q706	5.1V DC	4.7V DC	2.5V DC
Q707	5.1V DC	4.7V DC	2.5V DC

All voltages measured on AVO 8 MkV.

TS80 CIRCUIT DIAGRAM

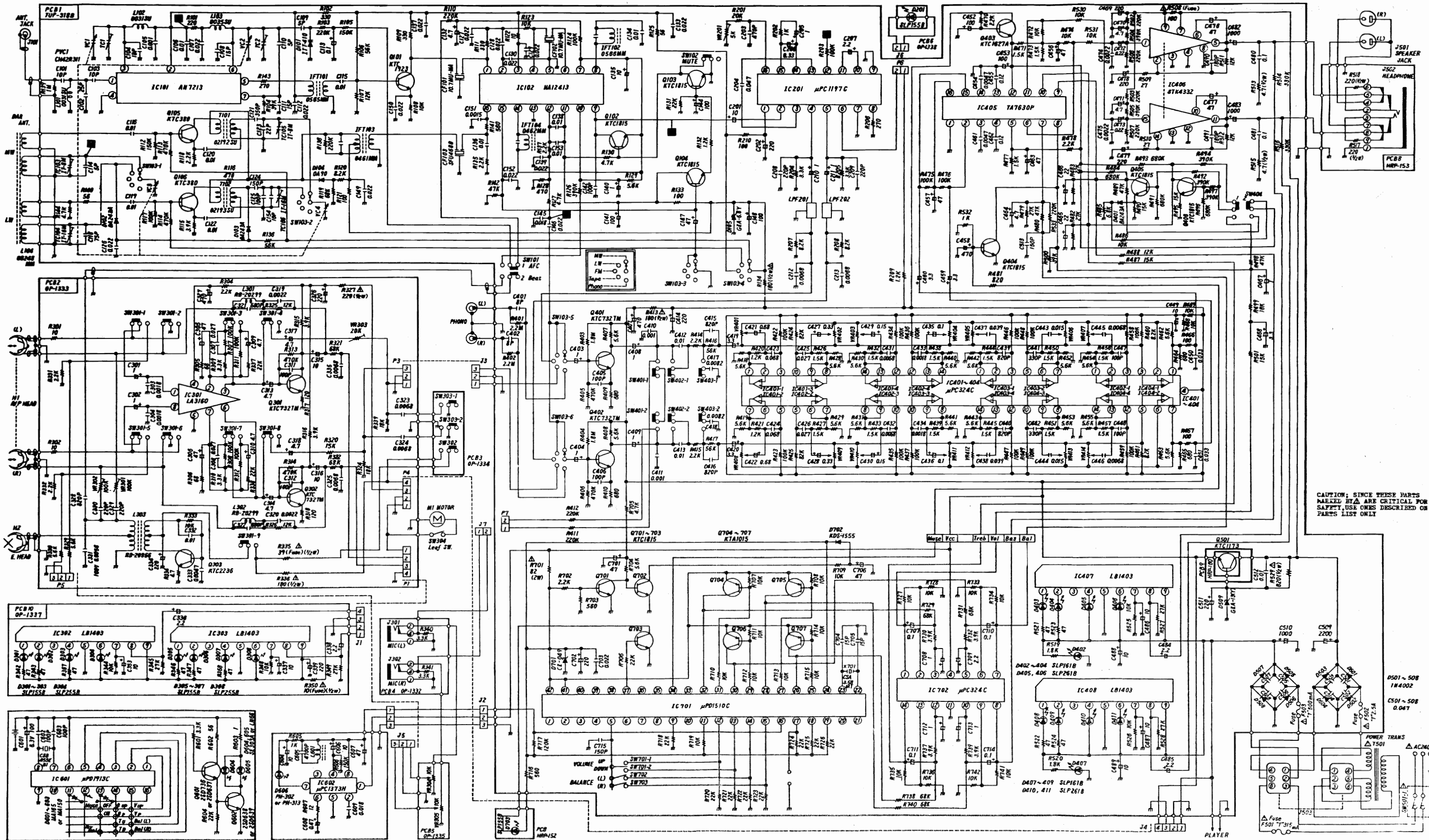

CAUTION: SINCE THESE PARTS MARKED BY Δ ARE CRITICAL FOR SATISFY USE ONES DESCRIBED ON PARTS LIST ONLY

Note: All parts shown with either the symbol Δ or with an 'S' prefix on the part numbers; are safety critical items and must be replaced with items having an identical safety specification.

TS88 CIRCUIT DIAGRAM

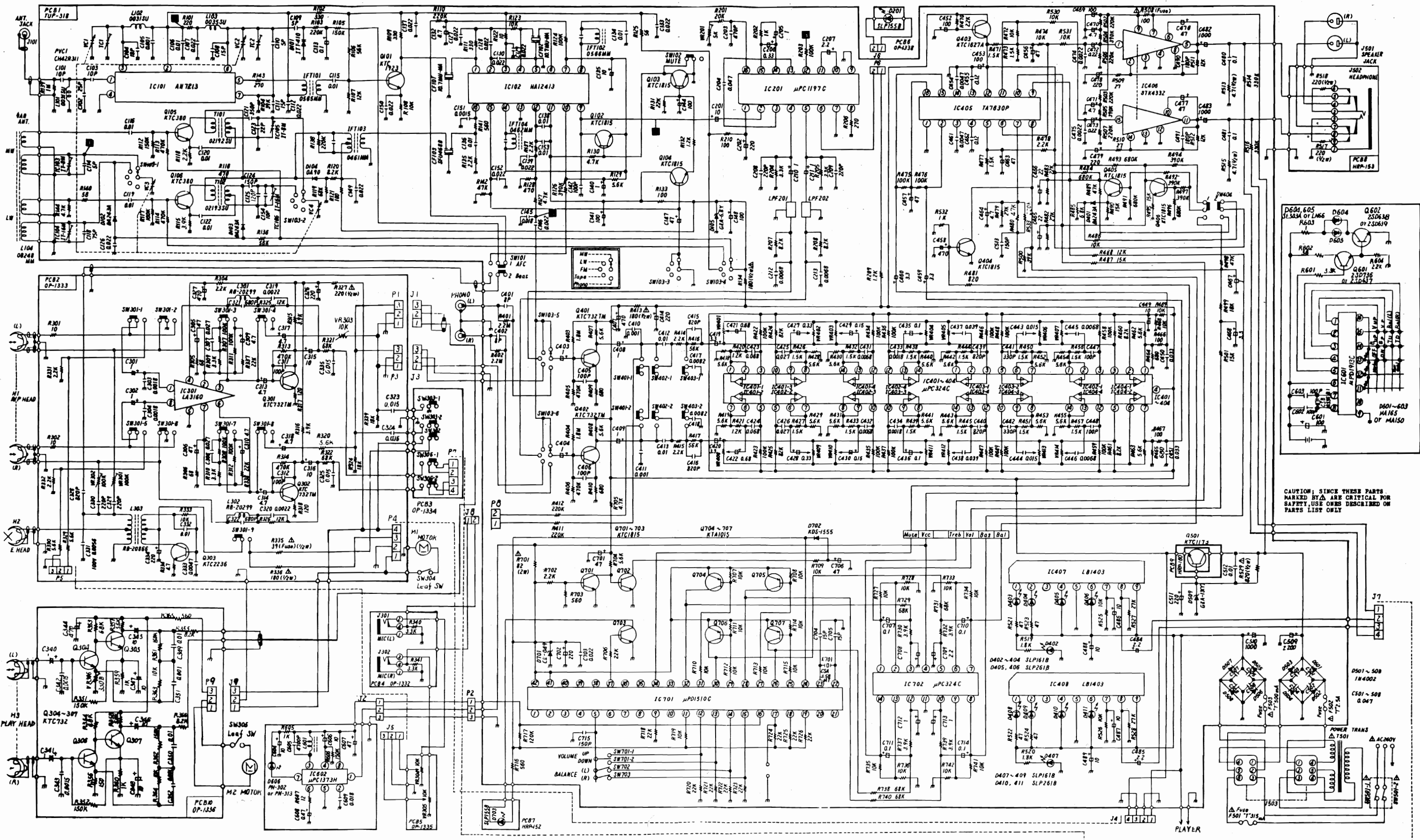

CAUTION: SINCE THESE PARTS MARKED BY Δ ARE CRITICAL FOR SATISFY, USE ONLY ONES DESCRIBED ON PARTS LIST ONLY

Note: All parts shown with either the symbol Δ or with an 'S' prefix on the part numbers; are safety critical items and must be replaced with items having an identical safety specification. All these items may be purchased direct from AMSTRAD CONSUMER ELECTRONICS PLC

AMSTRAD CONSUMER ELECTRONICS PLC
 MANUFACTURERS OF HI-FI AND AUDIO EQUIPMENT
 1-7 GARMAN ROAD, TOTTENHAM LONDON N17 0UF TELEPHONE 01-808 4505
 GRAMS AMSELEC LONDON TELEX 264869 AMSELE G

In keeping with our policy of continually improving our service, and the technical quality of our products, we reserve the right to change component types, manufacturers, sources of supply or technical specification at any time.