

# AMSTRAD



**PC1640**  
**PERSONAL COMPUTER**  
**PC-MD**  
**MONOCHROME DISPLAY**  
**PC-CD**  
**COLOUR DISPLAY**  
**PC-ECD**  
**ENHANCED COLOUR DISPLAY**  
**SERVICE MANUAL**

## CONTENTS

	Page
Technical Specification	2
Safety Tests	2
FD-3 Maintenance	3 - 14
Flow Charts	15 - 17
Hard Disc Installation Instructions	18
Switch Settings	19
Understanding bad sectors on a hard disc	20
Notes	21 & 22
Keyboard Exploded Diagram	23
Keyboard Control PCB Layout	24
Keyboard Schematic Diagram	24 & 25
PC1640 Electrical Parts List	26
PC1640/SD/DD/HD20 Cabinet Drawing & Parts List	27
PC1640/SD/DD/HD20 CPU P.C. Board	28
PC1640/SD/DD/HD20 CPU P.C. Board (Bottom View)	29
PC1640/SD/DD/HD20 Chassis Schematic Diagram	30
PC1640/SD/DD/HD20 Chassis Schematic Diagram	31
PC1640/SD/DD/HD20 Chassis Schematic Diagram	32
PC1640/SD/DD/HD20 Chassis Schematic Diagram	33
PC1640/SD/DD/HD20 Chassis Schematic Diagram	34
PC1640/SD/DD/HD20 Chassis Schematic Diagram	35
PC-MD Electrical Parts List	35
PC-MD Cabinet & Parts List	36
PC/MD Main/CRT/Volume P.C. Board	37
PC/MD Chassis Schematic Diagram - Power Supply	38
PC-MD Chassis Schematic Diagram - Monitor	39
PC-MD Alignment Instructions	40
PC-CD Electrical Parts List	40
PC-CD Electrical Parts List	41
PC-CD Alignment Instructions	41
PC/CD Chassis Schematic Diagram - Power Supply	42
PC/CD Chassis Schematic Diagram - Monitor	43
PC/CD Main P.C. Board	44
PC/ECD Cabinet & Parts List	45
PC-ECD Electrical Parts List	46
PC-ECD Alignment Instructions	47
PC-ECD RGB P.C. Board	48
PC/ECD CRT P.C. Board	48
PC-ECD Relay P.C. Board	48
PC/ECD Main P.C. Board	49
PC/ECD Chassis Schematic Diagram - TTL Decoder	50
PC/ECD Chassis Schematic Diagram - Power Supply	51
PC/ECD Chassis Schematic Diagram - Monitor	52

## TECHNICAL SPECIFICATION

Internal Graphics Adaptor, fully compatible			
640K system unit with all circuitry on a single motherboard			
8MHz 8086 processor			
Three full-size compatible expansion slots (even with hard disc option)			
One or two 360K 5 $\frac{1}{4}$ " floppy disks or one floppy with a 20 Megabyte hard disk drive.			
RS232 serial and parallel interface with standard connectors.			
Loudspeaker with volume control.			
Battery back-up real time clock and configuration RAM.			
Socket for 8087 maths co-processor			
Connector for light pen and/or joystick.			
Full sized keyboard.			
Numpack and Capslock.			
Keyboard joystick port.			
Two-button mouse with dedicated port on system unit.			
Choice of one of three displays (paper-white mono, colour, enhanced colour) with standard video connector.			
ECD monitor has .31mm pitch shadow mask.			
CD monitor has .42mm pitch shadow mask.			
Internal Graphics Adaptor provides:			
Mono (MD):			
80 column high resolution text with 9 x 14 dot characters.			
EGA compatible Monochrome graphics 640 x 350 lines.			
Colour (CD):			
(for use with CGA and 200-line EGA software)			
40/80 column text with 8 x 8 dot characters in 16 colours.			
Medium resolution graphics 320 x 200 lines in 4 colours.			
High resolution colour graphics 640 x 200 lines in 2 or 16 colours.			
Enhanced Colour (ECD):			
40/80 column text with 8 x 14 or 8 x 8 dot characters in 16 colours.			
High resolution colour graphics 640 x 200 lines in 2 or 16 colours.			
Extra-high resolution graphics 640 x 350 lines in 16 out of 64 colours.			
Dimensions (approx):			
Monitors (Unboxed)			
	WIDTH	HEIGHT	DEPTH
PC-MD	350mm	315mm	300mm
PC-CD	370mm	320mm	360mm
PC-ECD	370mm	320mm	360mm
System Unit	370mm	135mm	384mm
Gross Weights (approx):			
Monitors	(Boxed)		(Unboxed)
PC-MD		9.0Kg	8.0Kg
PC-CD		13.5Kg	11.5Kg
PC-ECD		13.5Kg	11.5Kg
System Unit	(Boxed)		(Unboxed)
PC-SD		8.9Kg	5.0Kg
PC-DD		10.5Kg	5.8Kg
PC-HD		11.0Kg	6.0Kg
Keyboard	(Boxed with system unit)		

## SAFETY TEST

All monitors are tested to the following specifications.

- Flash Test:** Test at 1.5kV RMS / 3 sec between the live and neutral poles of the mains lead and all accessible metal points on the exterior of the set.
- Insulation Resistance Test:** Test at 1.5kV RMS / 3 sec between the live and neutral poles of the mains lead and all accessible metal points on the exterior of the set to show a resistance greater than 4Mohms.
- Earth Continuity Test:** The resistance of the mains lead shall not exceed 0.5ohms.

**PLEASE NOTE:** When any work is completed on this unit, correct safety tests must be carried out to ensure continued electrical safety.

**PLEASE NOTE:** All parts shown with the part number prefix  $\Delta$  are Safety Items and must be replaced with similar items having an identical safety specification.

All those items may be purchased direct from AMSTRAD plc.

## AMSTRAD PLC

BRENTWOOD HOUSE, 169 KINGS ROAD, BRENTWOOD, ESSEX CM14 4EF.

TELEPHONE: 0277 230222. TELEGRAMS: AMSELEC BRENTWOOD. TELEX: 995417 AMSELE G.

## NOTE

The flow charts are for information only and for warranty purposes any faulty drive mechanism must be returned to Amstrad for replacement. Service Agents should not attempt to repair the mechanism.

Service Agents should note that the hard disc units are the most sophisticated mechanisms and should never be opened in a normal environment. If any attempts are made to open the hard disc unit the guarantee is then invalidated and Amstrad takes no responsibility to exchange the drive.

You should note further that there are two types of hard disc units in use i.e. Alps and Tandon. When ordering the replacement units make sure that the Part No. is either 175037 for the Alps drive or 60001 for the Tandon drive. This information applies only to the 20MB drives.

Amstrad reserves the right to amend the circuit or change the components without prior warning.

Use RP4 diagnostics expansion card or diagnostic disc for fault findings.

## FD3 MAINTENANCE

1. Introduction  
This maintenance manual is for the maintenance FD3
- 1-1 General  
The floppy disk Drive is a high precision equipment and requires the following Special Jigs, Tools, measuring instruments and Adjustment when repairing or changing parts.
2. Special Jigs, Tools and Measuring Instruments
- 2-1 List of Special Jigs and Tools  
CE diskette ..... Dysan 224/2A  
Blank diskette  
Cleaning diskette
- 2-2 List of Measuring Instruments  
Oscilloscope  
Brian  
Frequency Counter
- 2-3 CE Diskette (Alignment Diskette)  
This Diskette is used for the following adjustments and checks.  
R/W head radial position  
R/W head azimuth  
Index burst timing
3. Diagnosis Procedure
- 3-1 General  
Hard errors are often caused by an incorrect procedure erroneous programming or damaged diskette, and soft errors are often caused by dirty air or random electric noise. And other external factors are often considered to be drive failure or incorrect adjustment. Check that errors are repeatedly produced with the first diskette and that similar errors are also produced with other diskettes, unless obvious assembly trouble or damage are found in visual inspection.
- 3-2 Soft Error Detection and Correction  
Soft errors are generally caused by the following.
  - 1) Dirty air between the R/W Head and Disk. Normally this dirt is cleaned out by the liner in the diskette.
  - 2) Random electrical noise less than several microseconds.
  - 3) Delicate track misalignment and writing timing misalignment, these are not detected during writing, and may cause soft errors during reading.
  - 4) Incorrect ground of the drive or host system power supply.
  - 5) Incorrect spindle speed.

The following actions are required on the control side to recover the foregoing soft errors.

  - 1) Reread the track ten times or until data recovered.
  - 2) Access the head to an adjacent track if the error is not recovered by step (1) then return the head to the previous track.
  - 3) Repeat step (1).
  - 4) Recalibrate the head then access the previous track and repeat step (1).
  - 5) An error that cannot be recovered after taking these steps cannot be recovered.
- 3-3 Write Error  
Operate READ-AFTER-WRITE if an error occurs during the write operation.  
If the error cannot be recovered after operating READ-AFTER-WRITE more than four times, operate READ-AFTER-WRITE on another track to determine whether the diskette or the drive is responsible for the error. If the same error occurs on another track, change the diskette and repeat these steps. If the error still occurs, the drive has some fault. If the error does not occur, the diskette is defective.
- 3-4 Read Error  
Most errors are soft errors. Data can be recovered by following the recovery steps 3-2.
- 3-5 Seek Error  
If seek error occurs, recalibrate the head then access target track once more.  
If seek error occurs again, the drive has some faults.  
Most seek errors are caused by stepping motor trouble or stepping motor drive circuit trouble.
- 3-6 Compatibility Error  
In some cases, data written by one drive cannot be read by another drive.  
This is due to the following reasons:  
The check points are listed below.
  - 1) Incorrect alignment — 5-2
  - 2) The head output is low — 5-6
  - 3) Motor speed irregularity — 5-1
  - 4) Check if the recommended sector format is set up.

Test Point	Signal Name
TP1	READ AMP OUT +
TP2	READ AMP OUT -
TP3	GND
TP4	STEP
TP5	READ DATA
TP6	INDEX
TP7	WRITE PROTECT
TP8	TRACK 00
TP9	GND

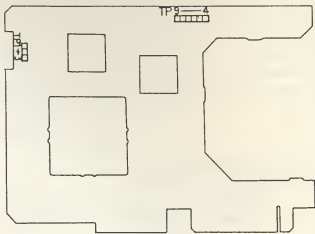

Fig. 3-7 Test Point Layout

4. Parts Exchange

4-1 Printed Circuit Board Exchange (See Fig. 4-1)

4-1-1 Printed Circuit Board Removal

- Remove the drive belt, stretched between the spindle pulley and the DC motor pulley by rotating the spindle pulley as the direction shown in Fig. 4-1. Be careful not to touch the inner surface of the drive belt and the side of the spindle pulley and DC motor pulley.
- Disconnect the connectors. (LED, P.C.B., Track 00 sensor, DC Motor P.C.B., Stepping Motor, Head F.P.C.).
- Unfasten four printed circuit board fixing screws.
- Remove the printed circuit board.
- Remove the insulating sheet.

Fig. 4-1 Printed Circuit Board Exchange

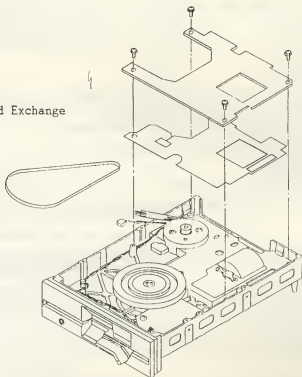

4-1-2 Printed Circuit Board Mounting and Adjustment

- Install the insulating sheet.
- Fix the printed circuit board with four screws.
- Reconnect the disconnected connectors, (LED, P.C.B., Track 00 sensor, DC motor P.C.B., Stepping motor, Head F.P.C.).
- Place the drive belt over the DC motor pulley completely and only partially on the spindle pulley.
- By rotating the spindle pulley, the rest of the belt will fit completely over.

#### 4-2 DC Motor P.C.B. Removal (See Fig. 4-2)

##### 4-2-1 DC Motor P.C.B. Removal

- Disconnect the connectors (Printed Circuit Board, DC Motor)
- Unfasten two DC motor P.C.B. fixing screws.
- Lift the right edge of the DC motor P.C.B. and pull it up.  
Be careful not to touch the spindle pulley with DC motor P.C.B.

##### 4-2-2 DC Motor P.C.B. Mounting and Adjustment.

- Install the DC motor P.C.B.
- Fix the DC motor P.C.B. with two screws.
- Reconnect the disconnected connectors. (Printed Circuit Board, DC Motor).

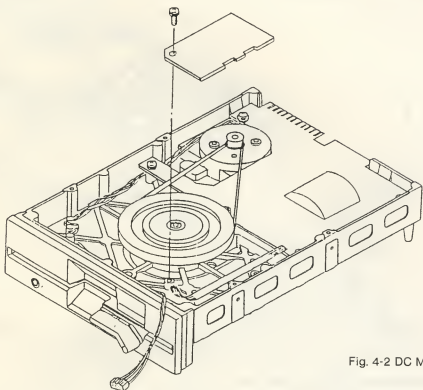

Fig. 4-2 DC Motor P.C.B. Removal

#### 4-3 Lever Exchange (See Fig. 4-3)

##### 4-3-1 Lever Removal

- Set the lever horizontally.
- Unfasten the fixed screw of the lever.
- Pull the lever forward.

##### 4-3-2 Lever Mounting

- Place the wide part of the clamp cam on the hub side and check that the lever shaft hole can be seen from above. ( Hub open state).
- Set the lever horizontally and insert from the front.
- Secure the lever with a screw.

Fig. 4-3 Lever Exchange

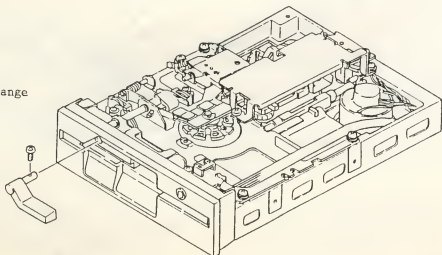

4-4 Bezel Exchange (See Fig. 4-4)

4-4-1 Bezel Removal

- a) Remove the lever as described in 4-3-1.
- b) Unfasten two bezel fixing screws.
- c) Pull the bezel forward.

4-4-2 Bezel Mounting

- a) Insert the bezel from the front.
- b) Secure the bezel with two screws.
- c) Mount the lever as described in 4-3-2.

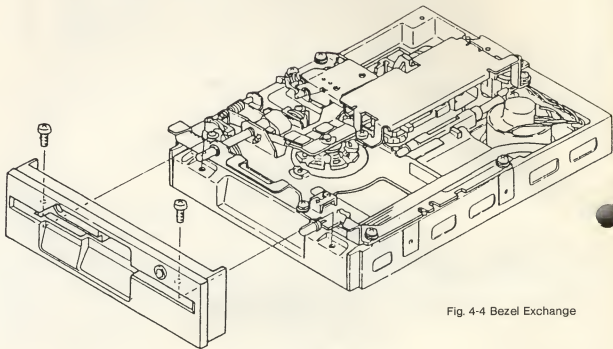

Fig. 4-4 Bezel Exchange

4-5 LED Assembly Exchange (See Fig. 4-5)

4-5-1 LED Assembly Removal

- a) Disconnect the connectors. (Index sensor, W/P sensor and Printed Circuit Board).
- b) Unfasten the LED Assembly fixing screw.
- c) Pull it back.

4-5-2 LED Assembly Mounting and Adjustment

- a) Install the LED Assembly by inserting the LED into the LED insertion hole on the bezel.
- b) Fix the LED Assembly with a screw.
- c) Reconnect the disconnected connectors. (Index sensor, W/P sensor and Printed Circuit Board).

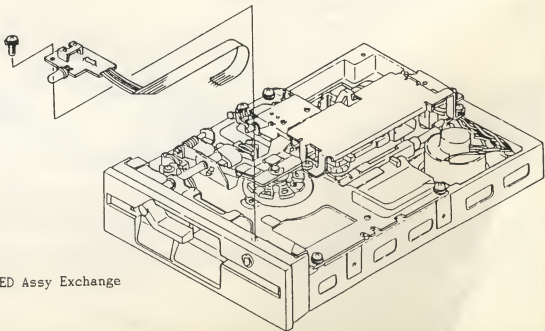

Fig. 4-5 LED Assy Exchange

#### 4-6 Ejector Assembly Exchange (See Fig 4-6)

##### 4-6-1 Ejector Assembly Removal

- a) Set the lever vertical (Clamp state).
- b) Unfasten three cover fixing screws.
- c) Remove the cover.
- d) Insert protection paper (High quality white paper approximately 10 x 30 mm between the top head and bottom head to protect them).
- e) Unfasten two ejector assembly fixing screws.
- f) Lift the top head carefully. (approximately 2-3mm) then remove the ejector assembly.

##### 4-6-2 Ejector Assembly Mounting and Adjustment

- a) Lift the top head and insert the ejector assembly under the head arm.
- b) Place the ejector assembly as two half punched bosses fit into the holes of the lever frame then secure the ejector assembly with two screws.
- c) Remove the protect sheet between the top head and bottom head.
- d) Fix the cover with one short screw and two long screws.  
(Short screw for inner hole).

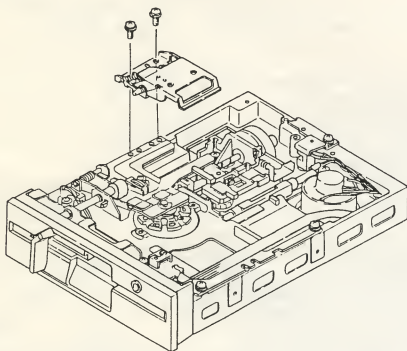

Fig. 4-6 Ejector Assembly Exchange

#### 4-7 Lever Frame Assembly Exchange (See Fig. 4-7)

##### 4-7-1 Lever Frame Assembly Removal

- a) Remove the lever as described in 4-3-1.
- b) Remove the bezel as described in 4-4-1.
- c) Remove the LED assembly as described in 4-5-1.
- d) Remove the ejector assembly as described in 4-6-1.
- e) Unfasten four lever frame fixing screws.
- f) Lift the lever frame assembly slightly making sure that the top head is not raised, and remove the lever frame assembly by sliding it to the left.

##### 4-7-2 Lever Frame Assembly Mounting and Adjustment

- a) Lift the top head slightly and slide the pad mounting arm of the lever frame assembly under the top head.
- b) Secure the lever frame assembly with four screws.
- c) Mount the ejector assembly as described in 4-6-2.
- d) Mount the LED assembly as described in 4-5-2.
- e) Mount the bezel as described in 4-4-2.
- f) Mount the lever as described in 4-3-2.
- g) Turn the lever slowly until it stops. By this operating, the hub assembly is placed in the best position for clamping automatically.
- h) Adjust the index burst time. (Refer to 5-5).

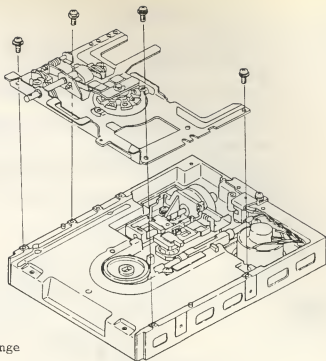

Fig. 4-7 Lever Frame Assy Exchange

#### 4-8 Head Assembly Exchange (See Fig. 4-8)

##### 4-8-1 Head Assembly Removal

- a) Remove the lever as described in 4-3-1.
- b) Remove the bezel as described in 4-4-1.
- c) Remove the LED assembly as described 4-5-1.
- d) Remove the ejector assembly as described in 4-6-1.
- e) Remove the lever frame assembly as described in 4-7-1.
- f) Disconnect the connectors (Head F.P.C.)
- g) Unfasten the screws fixing the guide shaft keeper A and B, then remove keeper A and B.
- h) Hold the bottom head and lift the head assembly slightly then carefully remove by sliding to the right.
- i) Remove the guide shaft from the head assembly in backward direction.

##### 4-8-2 Head Assembly Mounting and Adjustment

- a) Insert the guide shaft into head assembly and mount on the chassis so that the follower pin of the head assembly fits into the screw of the screw shaft of the stepping motor assembly by sliding to the left.
- b) Secure guide shaft keeper A and B with two screws.
- c) Reconnect the disconnected connectors (head F.P.C.).
- d) Mount the lever Frame assembly as described in 4-7-2.
- e) Mount the ejector assembly as described in 4-6-2.
- f) Mount the LED assembly as described in 4-5-2.
- g) Mount the bezel as described in 4-4-2.
- h) Mount the lever as described in 4-3-2.
- i) Adjust the radial track alignment (5-2), index burst time (5-5), track00 sensor timing (5-3), head azimuth (5-4), resolution (5-7) and symmetry (5-8) after head mounting.

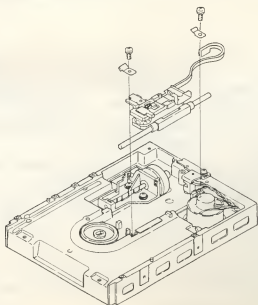

Fig. 4-8 Head Assy Exchange



#### 4-9 Stepping Motor Assembly Exchange (See Fig. 4-9)

##### 4-9-1 Stepping Motor Assembly Removal

- a) Remove the lever as described in 4-3-1.
- b) Remove the bezel as described in 4-4-1.
- c) Remove the LED assembly as described in 4-5-1.
- d) Remove the ejector assembly as described in 4-6-1.
- e) Remove the lever frame assembly as described in 4-7-1.
- f) Remove the head assembly as described in 4-8-1.
- g) Disconnect the connector (stepping motor).
- h) Unfasten two stepping motor fixing screws.
- i) Remove the stepping motor assembly. Be careful not to touch the screw shaft of the stepping motor.

##### 4-9-2 Stepping Motor Assembly Mounting and Adjustment

- a) Install the stepping motor assembly in the chassis, and fix with two screws.
- b) Reconnect the disconnected connector (stepping motor).
- c) Mount the head assembly as described in 4-8-2.
- d) Mount the lever frame assembly as described in 4-7-2.
- e) Mount the ejector assembly as described in 4-6-2.
- f) Mount the LED assembly as described in 4-5-2.
- g) Mount the bezel as described in 4-4-2.
- h) Mount the lever as described in 4-3-2.
- i) Adjust the radial track alignment (5-2), index burst time (5-5), track00 sensor timing (5-3), head azimuth (5-4), resolution (5-7) and symmetry (5-8) after mounting.

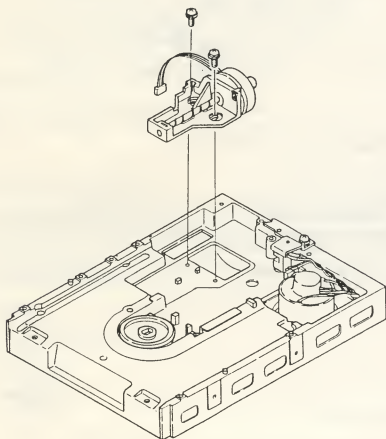

Fig 4-9 Stepping Motor Assy Exchange

#### 4-10 DC Motor Assembly Exchange (See Fig. 4-10)

##### 4-10-1 DC Motor Assembly Removal

- a) Remove the drive belt as described in 4-1-1 a)
- b) Disconnect the connector (DC Motor)
- c) Unfasten two DC motor assembly fixing screws.
- d) Remove the DC motor assembly.

##### 4-10-2 DC Motor Assembly Mounting and Adjustment

- a) Secure the DC Motor assembly with two screws.
- b) Reconnect the disconnected connector (DC Motor).
- c) Replace the drive belt as described in 4-1-2 d), e).
- d) Adjust the spindle speed (5-1) after mounting.

Fig. 4-10 DC Motor Assy Exchange

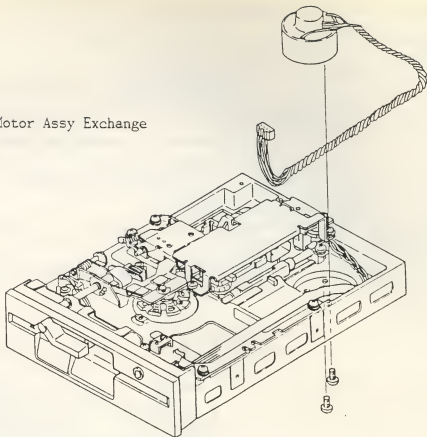

4-11 Track00 Sensor Assembly Exchange (See Fig. 4-11)

- a) Unfasten three cover fixing screws.
- b) Remove the cover.
- c) Disconnect the connector (track00 sensor).
- d) Unfasten track00 sensor assembly fixing screws
- e) Remove the track00 sensor assembly

4-11-2 Track00 Sensor Assembly Mounting and Adjustment

- a) Mount the track00 sensor assembly with a screw.
- b) Reconnect the disconnected connector (track00 sensor).
- c) Fix the cover with one short screw and two long screws. (short screw for inner hole).
- d) Adjust the track00 sensor after mounting (refer to 5-3).

Fig. 4-11 Track00 Sensor Assy Exchange

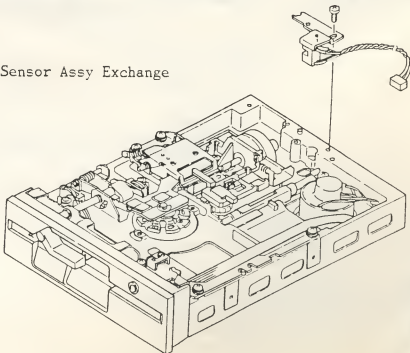

## 5. Adjustment and Check

### 5-1 Spindle Speed Adjustment (See Fig. 5-1)

- Insert and clamp a blank diskette while DC motor is rotating.
- Move the head to track 00.
- Connect the frequency counter to TP6.
- Check that counter shows  $200 \pm 3$ ms.
- If the counter value shows out of range, turn the variable resistor (VR1) on DC motor board located bottom of drive. Spindle speed goes slower by turning to the left, faster to the right.
- If the counter value shows out of range after taking method (e), exchange the drive belt and repeat from (d).
- If the counter value still shows out of range after exchanging the drive belt, exchange the DC motor and/or DC motor board.

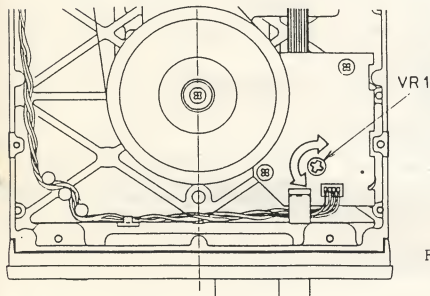

Fig. 5-1 Spindle Speed Adjustment

### 5-2 Radial Track Adjustment (See Fig. 5-2)

- Insert and clamp a CE diskette.
- Move the head to track 16 and check the cat's-eye waveform of the top and bottom heads.
- Adjust as follows if one of the top or bottom head is not more than 75% in an amplitude ratio of two waveforms.
- Slightly loosen the fixed screws of the stepping motor assembly and move the stepping motor back or forward to adjust the amplitude ratio. The amplitude of two wave forms should be nearly the same, then tighten the stepping motor assembly fixing screw.
- Check the cat's-eye waveform of top and bottom heads.
- Repeat from (d) if adjustment fails.

#### Measuring Condition

Channel 1 -TP1 (10mv/div)  
Channel 2 -TP2 (10mv/div), invert  
Mode -ADD  
Sweep -20ms/div

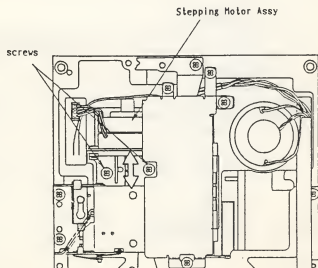
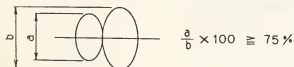

Fig. 5-2 Radial Track Adjustment

5-3 Track00 Adjustment

- Insert a CE diskette
- Continuously seek between track00 and track02 at the minimum access time between tracks of DFD222A specifications.
- Adjust track00 sensor assembly so that the step signal and track00 signal are on the timing as shown in Fig. 5-3. The secure with the fixed screw.

Measuring condition

Channel 1 -TP4 (0.2V/div)  
 Channel 2 -TP8 (0.2V/div)  
 Mode -DUAL  
 Sweep -10ms/div

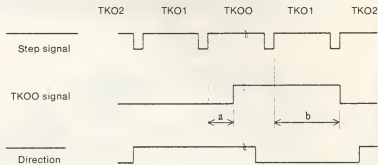

The minimum access time between tracks	a	b
6ms/track	3ms max	8ms max

Fig. 5-3 Track00 Adjustment

5-4 Azimuth Check

- Insert and clamp a CE diskette.
- Move the heads to track 34 and check with third waveform set if azimuth waveforms of top and bottom heads are as described in Fig. 5-4.
- Exchange the head assembly if the azimuth of one of the top or bottom head is not as shown in Fig. 5-4.

Measuring condition

Channel 1 -TP1 (10mv/div)  
 Channel 2 -TP2 (10mv/div), invert  
 Mode -ADD  
 Sweep -1ms/div  
 Trigger -TP6

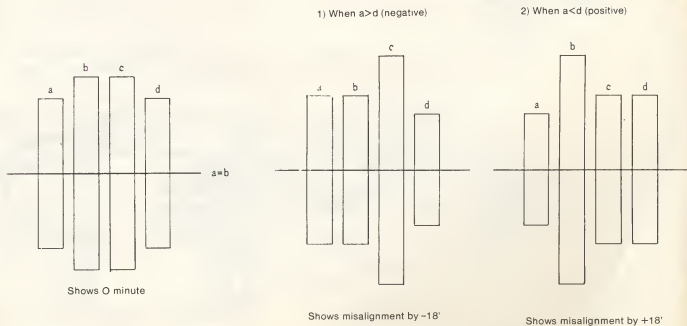

Head azimuth =  $0 \pm 18'$

### 5-5 Index Burst Time Adjustment

- Insert and clamp a CE diskette.
- Move the head to track 34 and check the index burst time of the top and bottom heads. Adjust if the timing of one of the top or bottom head is not as shown in Fig. 5-5.
- Move the index sensor assembly back or forward by slightly loosening the index sensor assembly fixing screw to adjust the index burst time, then secure with the screw.
- Check the index burst time of the top and bottom heads.
- Repeat from (c) if adjustment fails.

#### Measuring condition

Channel 1 -TP1 (10mv/div)  
Channel 2 -TP2 (10mv/div), invert  
Mode -ADD  
Sweep -100 us/div  
Trigger -Edge connector J2 - 8, slope = (-)

Index

Head Reading  
Output Signal

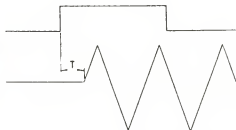

$$T = 200 \pm 200 \mu s$$

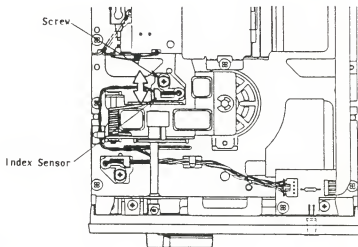

Fig. 5-5 Index Burst Time Adjustment

### 5-6 Lever Check

- Insert and clamp a blank diskette.
- Move the heads to track 39 and write 2F by the top and bottom heads.
- Check that the average output levels of the top and bottom head is more than 270mV. Perform the following if the output level is below the required standard.
- Insert another blank diskette and reconfirm.
- Check the spindle speed as described in 5-1.
- Change the oscilloscope mode to the CHOP mode and check the TP1 and TP2 outputs. Exchange the printed circuit board of one output is smaller than another one or missing, even though the probes are normal.
- Exchange the head assembly if no problems are encountered in (d), (e).

#### Measuring condition

Channel 1 -TP1 (10mv/div)  
Channel 2 -TP2 (10mv/div), invert  
Mode -ADD  
Sweep -20ms/div  
Trigger -TP6

Head Reading Output Signal (TP1-TP2)

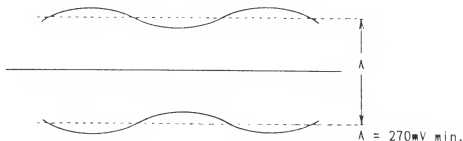

Fig. 5-6 Level Check

- 5-7 Resolution Check
- Insert and clamp a black diskette.
  - Move the heads to track 39, write 1F and 2F by the top head and measure the average output level of each frequency.
  - Write 1F and 2F by the bottom head and measure the average output level of each frequency.
  - The resolution is higher than 55%, and calculation shall be made as follows:

$$\text{Resolution} = 2F \text{ output (mV)} / 1F \text{ output (mV)} \times 100$$

- Move the heads to track 00, write 1F and 2F by the top head and measure the average output level of each frequency.
- Write 1F and 2F by the bottom head and measure the average output level of each frequency.
- The resolution is lower than 95%.

Measuring condition

Channel 1 -TP1 (10mv/div)  
 Channel 2 -TP2 (10mv/div), invert  
 Mode -ADD  
 Sweep -20ms/div  
 Trigger -TP6

5-8 Symmetry Check.

- Insert and clamp a blank diskette.
- Move the heads to track 00 and write 1F by the top and bottom heads.
- Check the symmetry as described in Fig. 5-8.
- Exchange the head assembly if the symmetry is out of the range as described in Fig. 5-8 on only one head side.
- Exchange the printed circuit board if symmetry is out of the range on both heads.
- If the symmetry is still out of the range, exchange head assembly or printed circuit board that was not exchanged on the previous step.



Fig. 5-8 Symmetry Check

Measuring condition

Channel 1 -TP1 (0.1V/div)  
 Channel 2 -NC  
 Mode -CH1  
 Sweep -0.5 us/div  
 Trigger -INTERNAL, Slope = (+)

5-9 Write Protect Sensor Check

- Load and unload a blank diskette which is not write protected, and check that write protect sensing is definitely made using Brian.
- If the write protect sensing does not work well, exchange lever frame assembly according to 4-7.
- Repeat from (a).

5-10 Head Cleaning

- If you tend to clean the heads, use the special diskette which is sold as "cleaning diskette". We would recommend the wet type cleaning diskette that uses "cleaning liquid".

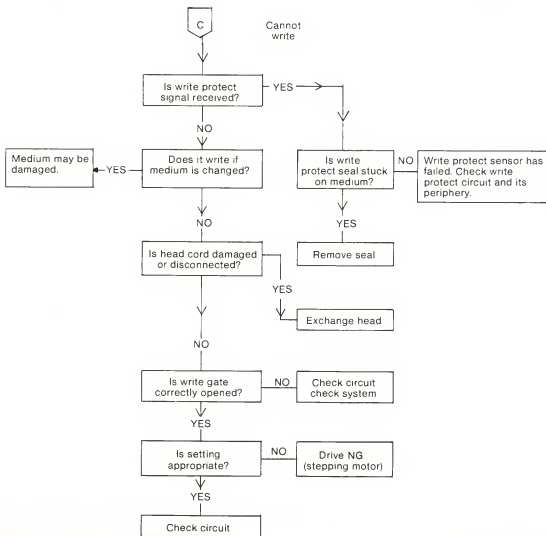
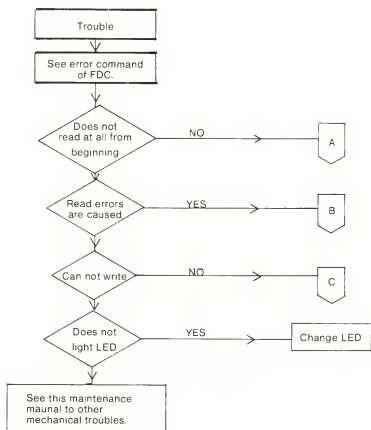

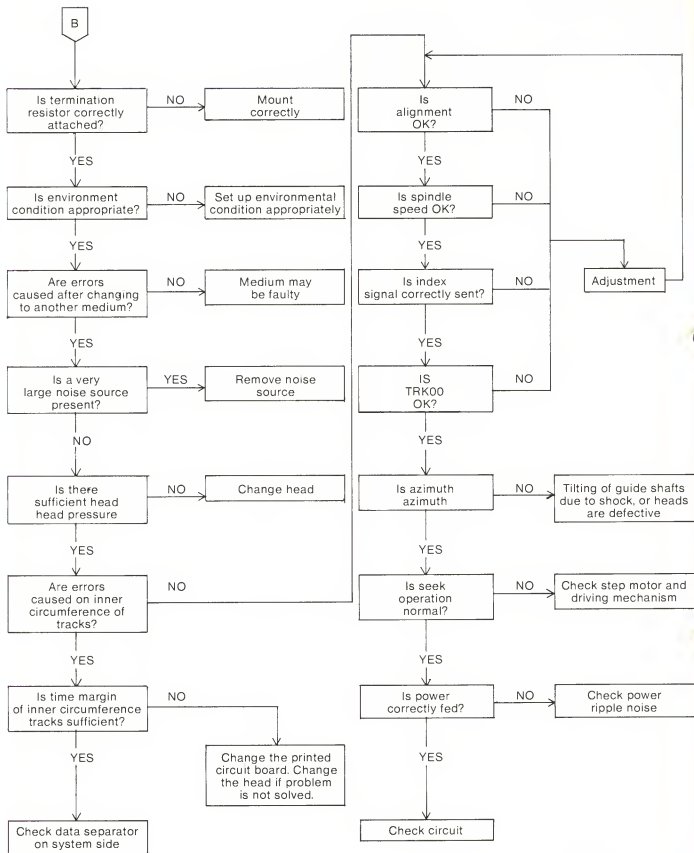

(Read errors are caused)



### FD-3 FLOWCHART

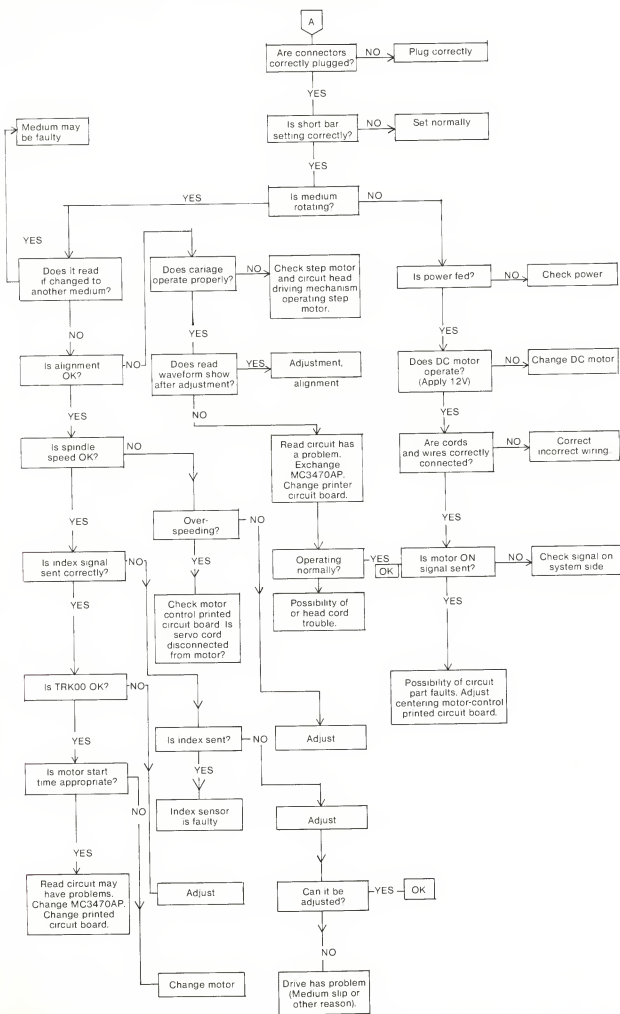

## HARD DISC INSTALLATION ON PC1640

PC1640 hard disc comes ready installed with the necessary software. That is discs 1 to 4 that are supplied ready with the machine.

However in the case of a disc failure it may be necessary to reinstall the supplied software.

This is done in the following way:

1. Put disc one into drive A: and boot up the system.
2. Put disc four into drive A: and type **CD\SUPPLEME** and press return.
3. Type **HDFORMAT** and press return.
4. Answer **YES** to the screen prompt.
5. When HDFORMAT is completed remove disc four and replace with disc one.
6. Type **CD\** and press return.
7. Type **FDISC** and press return.
8. Press return every time you are asked a question.
9. With disc one still in drive A: type **FORMAT C:/S** and press return.
10. When formatting is finished replace disc one with disc four.
11. Type **CD\SUPPLEME** and press return.
12. Type **CONFIG** and press return.

After typing CONFIG the machine will proceed to copy the four system discs to the hard disc. After copying each disc you will be prompted to insert the next disc. You do not need to know in which order to insert the discs because the machine will tell you which disc is needed next.

The system is now installed and should be tested by rebooting the machine.

It should be noted that if the hard disc is ok but the software has been corrupted or deleted you can reinstall the software without reformatting. This is done by following steps 11 and 12.

## IMPORTANT

PLEASE READ BEFORE SWITCHING ON

THE PC1640 SYSTEM UNIT CAN BE USED WITH EITHER A PC-MD MONOCHROME DISPLAY, A PC-CD COLOUR DISPLAY OR A PC-ECD ENHANCED COLOUR DISPLAY. THERE IS A 10 POSITION DIP SWITCH AT THE BACK OF THE SYSTEM UNIT THAT MUST BE ADJUSTED FOR USE WITH EITHER OF THE COLOUR DISPLAYS. PLEASE LOOK AT THE FOLLOWING CHART AND ADJUST THE DIP SWITCHES ACCORDING TO THE DISPLAY YOU HAVE FOR SERVICE.

	DIP SWITCHES									
	1	2	3	4	5	6	7	8	9	10
PC-MD	OFF	OFF	ON	OFF	ON	ON	ON	OFF	OFF	OFF
PC-CD	OFF	OFF	OFF	ON	ON	ON	ON	OFF	OFF	OFF
PC-ECD	OFF	ON	ON	OFF	OFF	ON	ON	ON	OFF	OFF

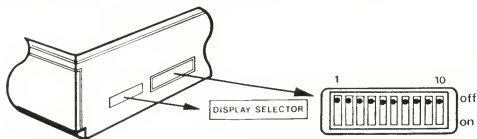

### DISPLAY SELECTOR SWITCH SETTINGS

The display selector switch settings determine how the IGA (Internal Graphics Adaptor) is configured when the machine is powered on or reset. These switch settings can be overridden by software. In particular by the **DISPLAY** command which is installed on all Hard Disc PCs and Disc 2 of your system discs. Many of the modes below have been given a name, unique to the Amstrad PC1640, in order to easily distinguish between them. These names are accepted by the **DISPLAY** command, which will switch to the requested mode, or print an error message if it is not possible or advisable.

Mode	Sw1	Sw2	Sw3	Sw4	Sw5	display	Description
<b>MDTEXT</b>	off	off	on	off	on	MD	MDA or Hercules Diag (1)
<b>MDMONO</b>	off	off	on	off	off	MD	EGA monochrome
<b>CDMONO</b>	on	off	off	on	on	CD	CGA compatible 40 column
	off	off	off	on	on	CD	CGA compatible 80 column (2)
<b>CDCOLOR</b>	on	off	off	on	off	CD	CGA compatible 40 column
	off	off	off	on	off	CD	CDA compatible 80 column
<b>ECD200</b>	on	on	on	off	off	ECD	EGA 200 lines
<b>ECD350</b>	off	on	on	off	off	ECD	EGA 350 lines (3)

all modes:	SW6	SW7	SW8		SW9	SW10
	x	x	on - PC ECD off - PC MD or PC CD		off	off

- (1) Recommended setting for PC MD
- (2) Recommended setting for PC CD
- (3) Recommended setting for PC ECD

x = don't care

## UNDERSTANDING BAD SECTORS ON A HARD DISC

Most hard discs have a number of manufacturing faults, this is completely normal.

These faulty areas are known as bad sectors.

During the formatting procedure of a hard disc these bad sectors are marked so that they are not used, therefore they do not cause any problems.

There is allowance made for one bad sector in each megabyte of disc space. Therefore as one bad sector equals 10240 bytes the total number of bytes allowed on a 20 megabyte hard disc is 204800 bytes which is 200k.

To see the amount of bad sectors on a hard disc type CHKDSK at the C> prompt or place your MS-DOS disc in drive A: and type CHKDSK C:

It is sometimes suggested that by running HDFORMAT the number of bad sectors can be reduced. This is not correct.

## RP4/RP5-2 DIAGNOSTICS

The PC1640 diagnostics card is RP5-2 as opposed to RP4 which was the PC1512 diagnostics.

RP5-2 is a plug in diagnostics card that can be fitted to any of the 1640 expansion slots.

It comes supplied with an IC clip which is placed over IC108.

Note that the pin on the clip with most wires attached connects to pin 10 of IC108.

Also supplied are two loopback connectors one each for serial and parallel ports.

There is also a disc supplied with RP5-2 which will check the VDU.

It should be noted that RP5-2 will perform on a PC1512 exactly as RP4 but RP4 will not run full tests on PC1640.

The reason for this is that RP4 cannot check the 1640 ECD display.

When using RP5-2 on a 1640 the VDU tests are not performed but are run from the supplied disc.

If using RP5-2 on a 1512 the VDU tests are all performed as they were on RP4.

Note that there are no selection switches to choose between 1512 or 1640 as it is automatically selected by the card.

The 1640 VDU tests contain all those previously performed by RP4 but it also contains extra 1640 specific tests.

For those people who already have RP4 the necessary chips to upgrade to an RP5-2 are available.

Full instructions on the use of RP5-2 are included with the product.

NOTES

NOTES

# KEYBOARD EXPLODED DIAGRAM

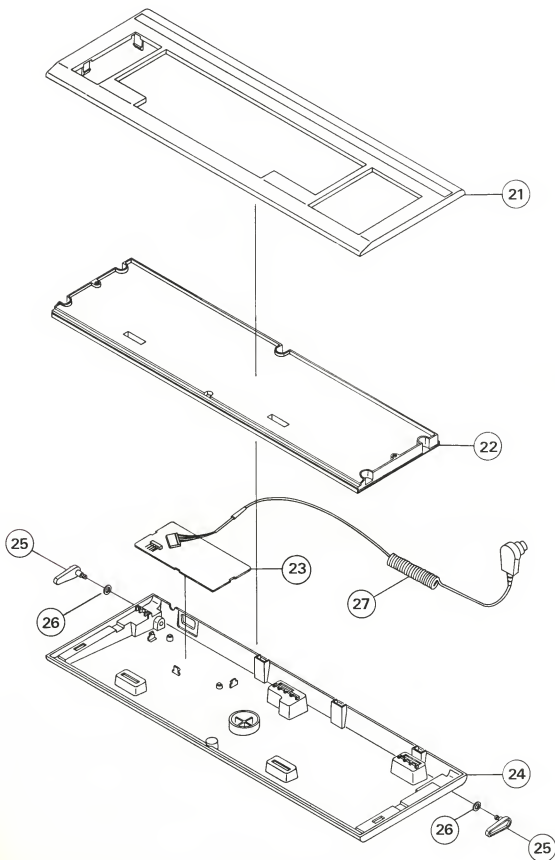

NOTE: FOR PART NUMBERS REFER TO PAGE 27.

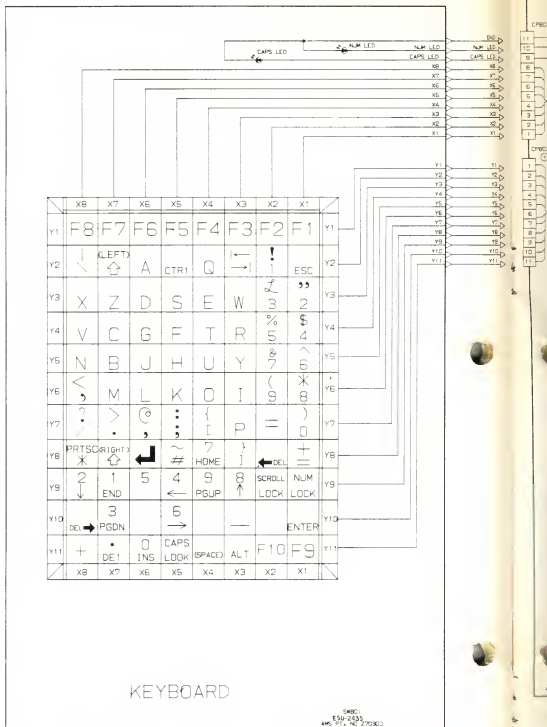

### KEYBOARD CONTROL PCB LAYOUT

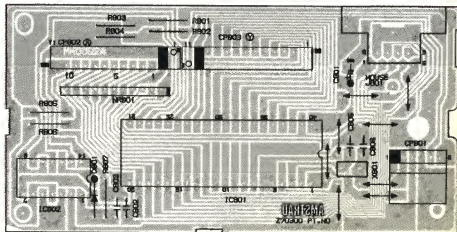





PC1640 ELECTRICAL PARTS LIST

Ref.	Description	Part No.
<b>I.C.s</b>		
IC101	IC MC1488	171378
IC102, 103	IC MC1489	171379
IC104	IC HD7406P	171380
IC105, 122	IC DN74LS373	170108
IC106	IC INS8250N	171381
IC107, 117	IC DN74LS240P	171382
IC108, 115, 121, 124, 909, 914, 915	IC DN74LS244	171383
IC109	IC MBL8259A-2P	171384
IC110	IC DN74LS125P	171385
IC111	IC FDC91C36	175000
IC112	IC Z765APS	40018
IC113, 921	IC DN74LS174P	171387
IC114	IC UPD8253C-2	171388
IC116, 802	IC DN74LS14P	171389
IC118, 125	IC AMS40040	171391
IC119	IC MBL8086-2P	171392
IC123	IC DN74LS245P	171393
IC125	IC AMS40039	171577
IC126	IC AMS40041	171394
IC128	IC TC74HCU04P	40008/A
IC129	IC AMSTRAD 40043	171396
IC130	IC UPD8237AC-5	171397
IC132	IC AMSTRAD 40044	171578
IC134	IC MC146818P	171399
IC135-152	IC MN41256-15	171400
IC153, 154, 156, 157, 901- 908	IC TMS4464-12	175005
IC155, 158	IC MT4264-15	175006
IC171	IC AMS40096 PAL16L8A2NC	40096
IC401	IC LA4140	170111
IC801	IC AMSTRAD 40042	171401
IC910	IC PEGA1A	175008
IC911	IC DN74LS367A	175009
IC912	IC AMS40097 PAL16L8ACN	40097
IC913	IC AMSTRAD 40100	40100
IC916	IC DN74LS00	175012
IC918	IC AMS40098 PAL16L8ACN	40098
IC919	IC DN74LS153	175014
<b>Transistors</b>		
Q101, 102, 105	TR 2SC1815Y	170447
Q103, 104, 106	TR 2SA1015Y	170453
<b>Diodes</b>		
D101-105, 501, 502	D ISS132T-77	171582
D106, 107	DZ MTZ4.7AT-77	175021
D108, 109	DZ GZA4.7Y	175022
D503	D LED TLS134A	171403
D801	D DS442X-BT	1422117

Description	Ref. No.	Part No.
<b>Resistors</b>		
5.6ohm Fuse	R181	175089
68ohm 1/4W	R907	10028
<b>Capacitors</b>		
47pF NPO	C805, 806	175128
68pF	C133	175129
1000pF	C411	175130
0.1uF	C501-506, 508, 509, 802, 803	175131
<b>Electrolytic Capacitors</b>		
47uF/16V	C801	20027
Ref. No.	Description	Part No.
<b>Coils</b>		
L101, 102	2.2uH	175024
<b>Switches</b>		
SW801	Switch Key Board	171409
SW901	Switch Slide Monitor Select	175023
<b>Crystal</b>		
X101	Crystal HC49U .843M	171372
X103	Crystal DSVT30032K	171374
X104	Crystal HC18RW24.0	171375
X105	Crystal HC18RW28.636	171376
X801	Ceramic Resonator KBR-6.0M	171377
X901	Crystal KXO-01-1 16.257M	175025
<b>P.C.B.s</b>		
PCB101	CPU PCB Assy MC0040A	175026
PCB102	Hard Disc Control PCB Assy MC0041A	175028
PCB801	Key Board Processor PCB Assy MK0002A	171412
<b>Jacks &amp; Connectors</b>		
14 Pin DIL	J101, 102, 123	170120
20 Pin DIL	J121, 122	170121
Socket D SUB	J801	175026
9 Way D Socket	JD104, 901	175131
6 Way DIN Socket	JD105	175132
<b>Miscellaneous</b>		
VR401	Volume Control CPU Unit 20kohm	171579
ICP101	ICP SOC315	171483

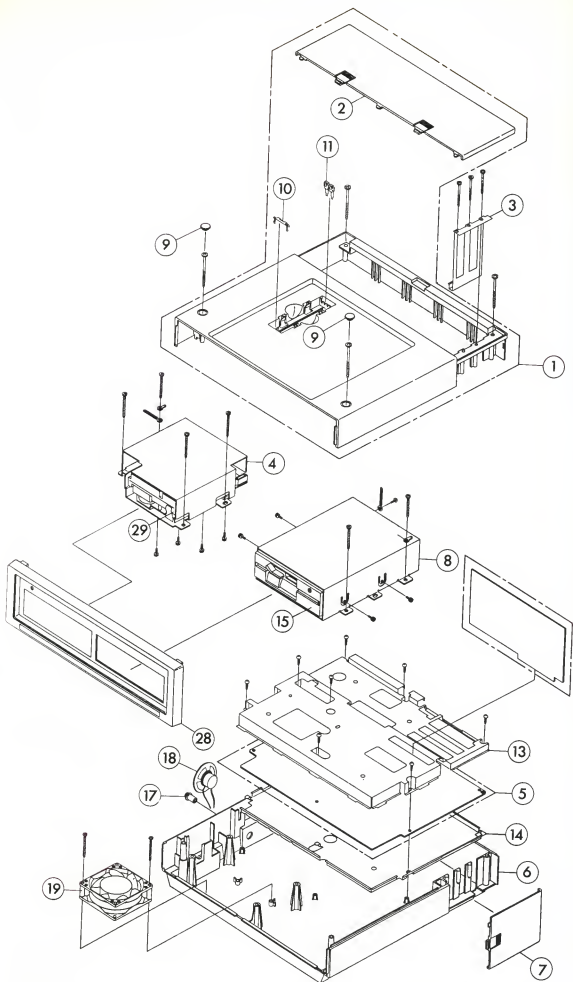

CABINET DRAWING FOR PC1640/SD/DD/HD20

PC1640 PARTS LIST

CABINET PARTS LIST

Ref.	Description	Part No.
1	Cabinet Top	175015
2	Lid Expansion PCB	175132
3	Plate Earth CPU	171364
4	Cabinet Front Assy. SD	175016
5	CPU PCB	175027
6	Cabinet Bottom	175038
7	Lid, Jack	171353
8	Frame FDD SD	171365
8a	Frame FDD A IN DD	171366
9	Screw Cap	171363
10	Plate Spring Battery	171367
11	Terminal Battery	171368
12	Cabinet Front Assy. DD	175089
13	Plate Shield Top	175017
14	Plate Shield Bottom	175018
15	F.D. Drive (A&B)	171576
17	Knob Volume	171362
18	Speaker	171370
19	Fan HD Unit	96001
	Spacer H.D. Fan	175036
21	Top Cabinet Keyboard	175039
22	Switch Key Board	171409
23	Keyboard PCB	171412
24	Cabinet Bottom Key Board Assy	171355
25	Stand Keyboard	171358
26	Washer	171659
27	Cord 6 Pin DIN / Keyboard	171420
28	Cabinet Front Assy, HD20	175032
29	HD20 Tandon	60001
29	HD20 ALPS	175037
	HD Control PCB	60003
	Cable 34 Way	60004
	Cable 20 Way	60005
	Mouse MS-2	171664
	Leg Rubber CPU Unit	171357
	Leg Rubber Key Board	171356
	Panel Front Assy	175033
	Frame HDD	175034
	Frame HDD Back	175035

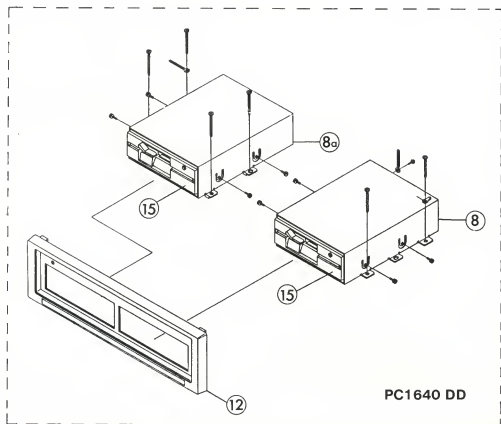
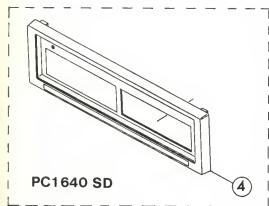

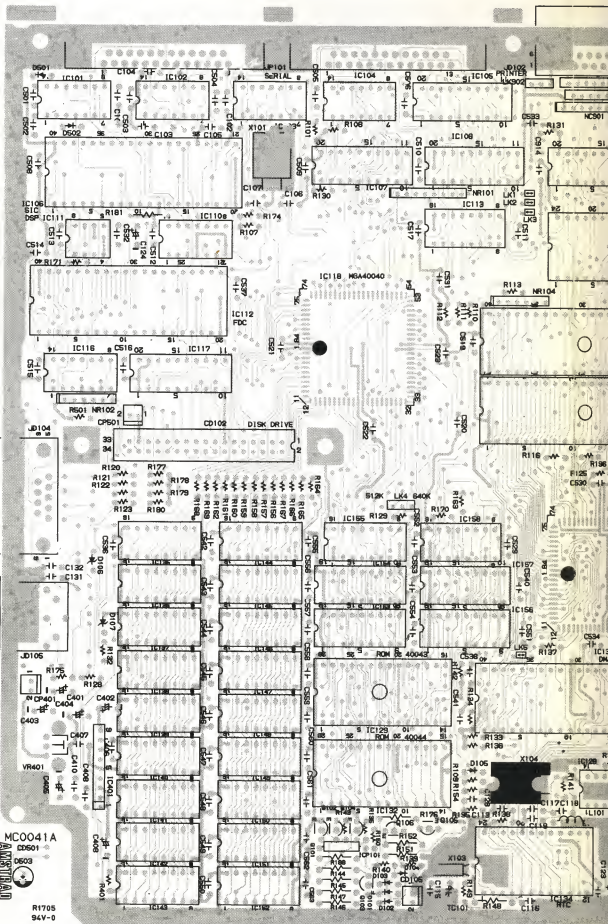

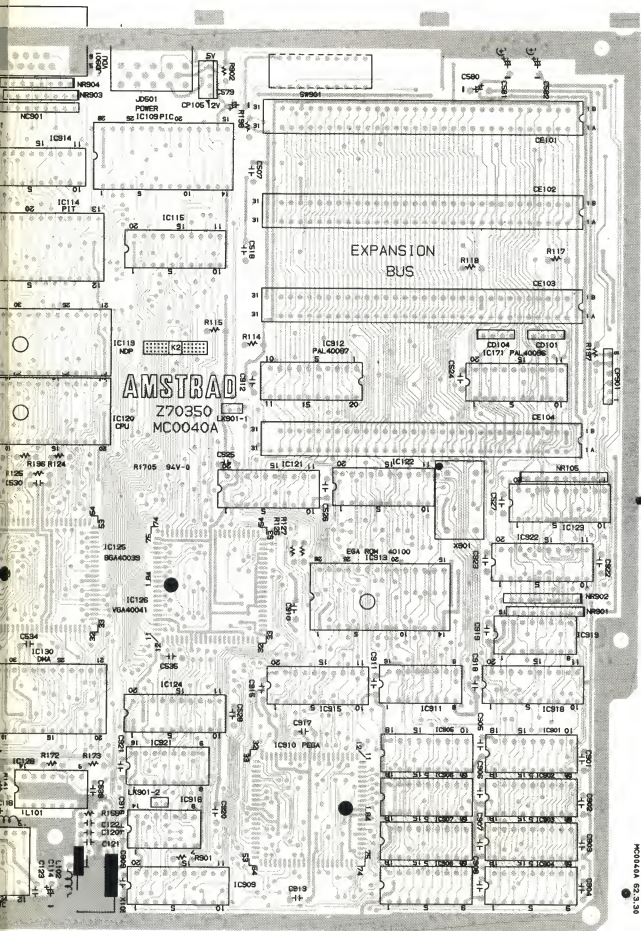

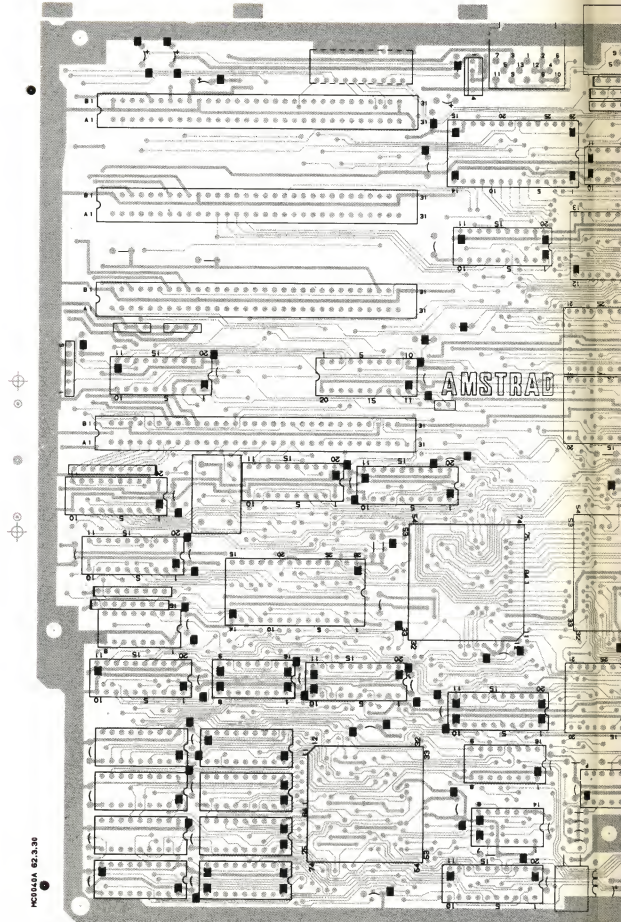

AMSTRAD

PC1640A 02.3.80

0 CPU P.C. BOARD (BOTTOM VIEW)

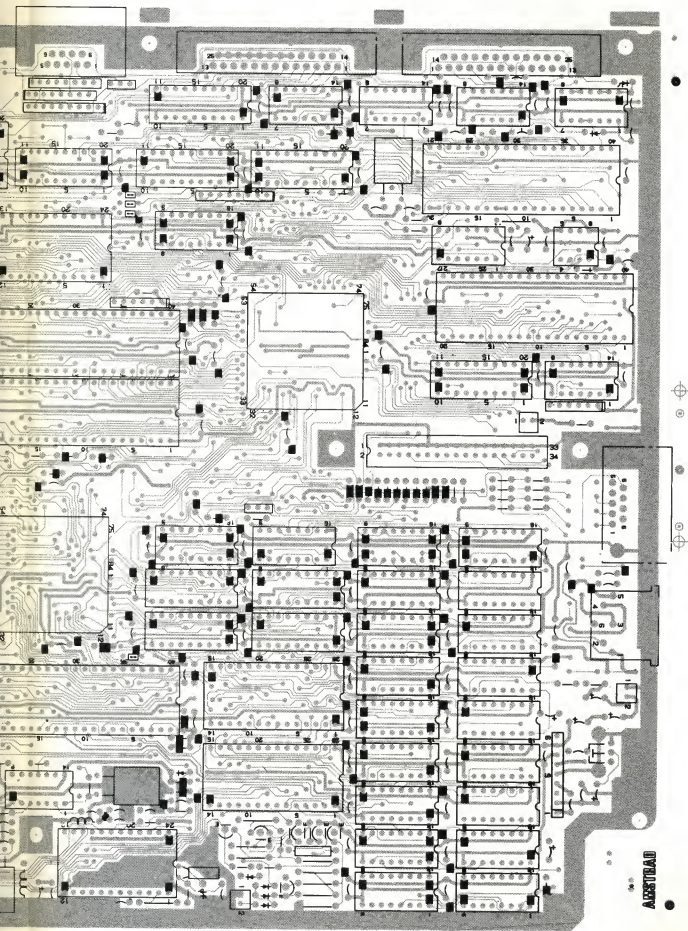

ALCOT/DAD





# CHASSIS SCHEMATIC DIAGRAM

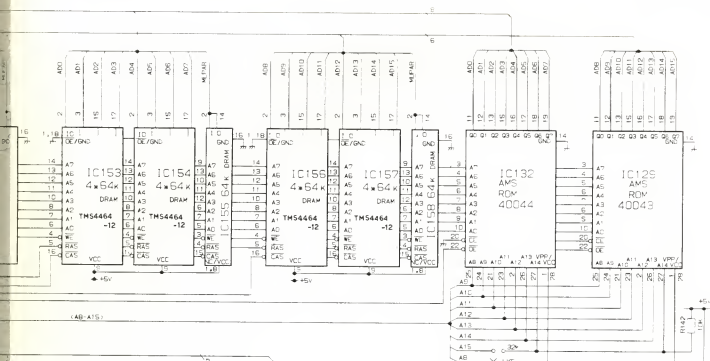

(CAB. A15)

ROM SIZE SELECT OPTION LINK

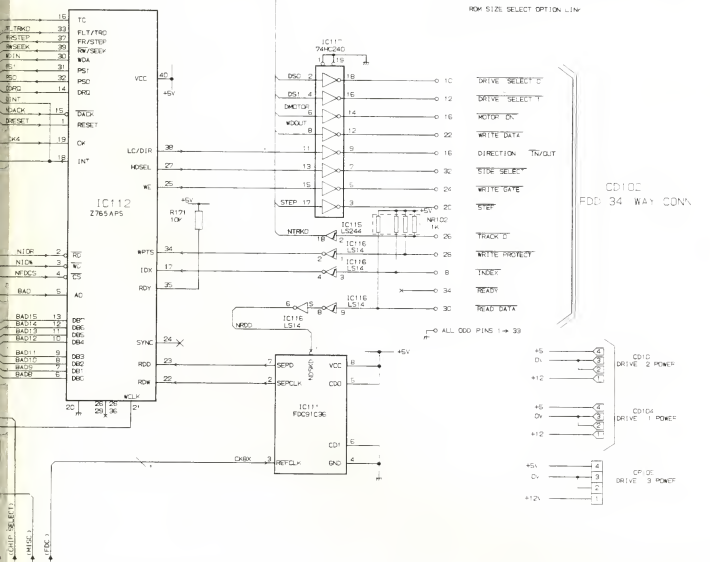

ATTENTION : LES PIÉCES MARQUÉES PAR UN ÉTANT DANGEREUSES AU POINT DE VUE SÉCURITÉ, N'UTILISER QUE CELLES IDENTIFIÉES DANS LA NOMÉCLATURE DES PIÉCES.

CAUTION: SINCE THESE PARTS MARKED BY ARE CRITICAL FOR SAFETY, USE ONES DESCRIBED ON PARTS LIST ONLY.

NOTE: THIS SCHEMATIC DIAGRAM IS THE LATEST AT THE TIME OF PRINTING AND SUBJECT TO CHANGE WITHOUT NOTICE.

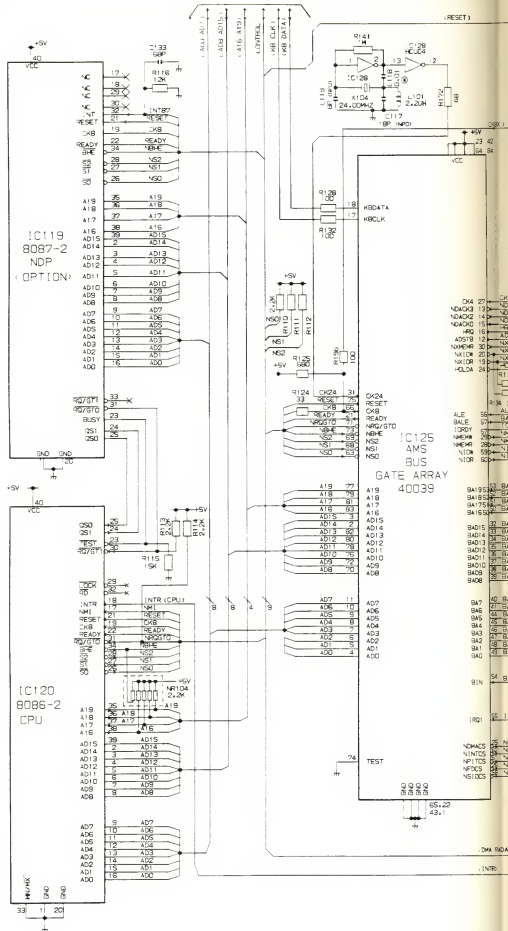

PC1640/SD/DD/HD20 CHASSIS SCHEMATIC DIAGRAM

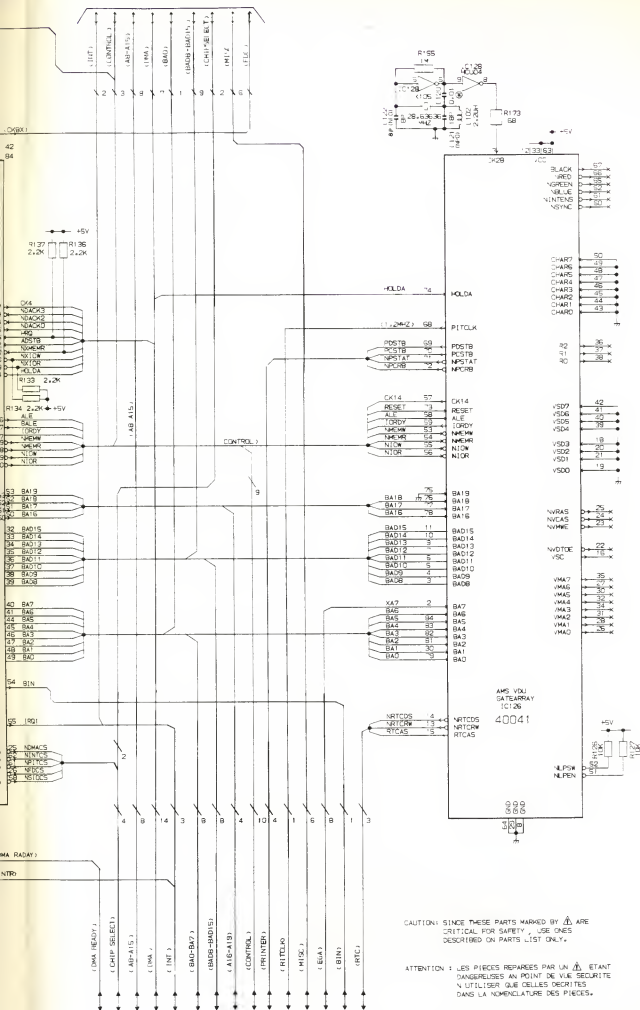

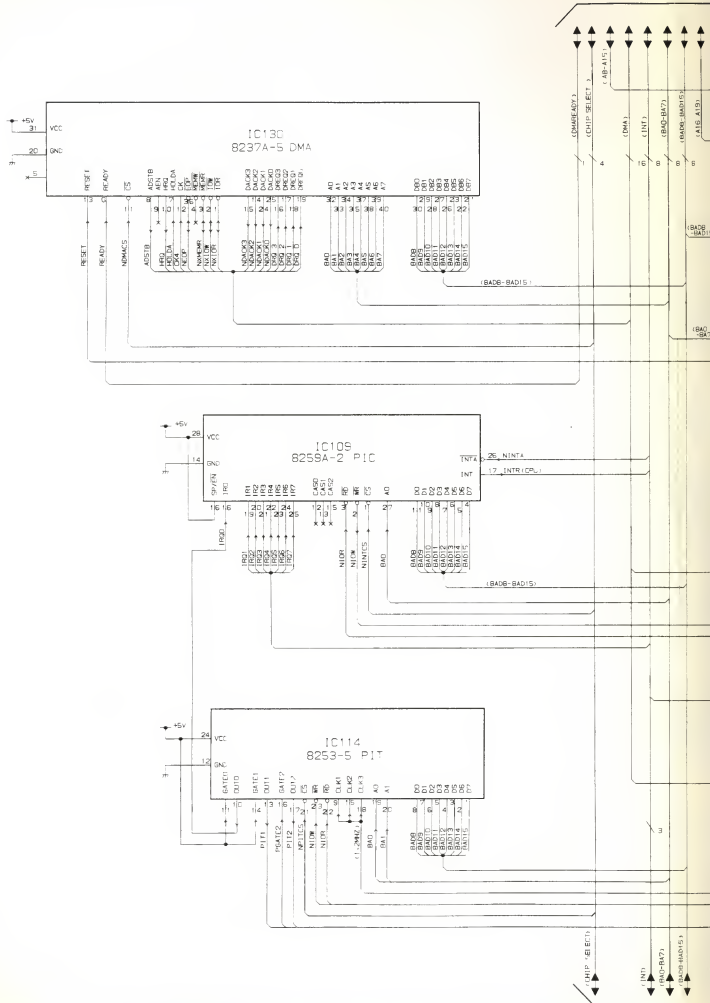



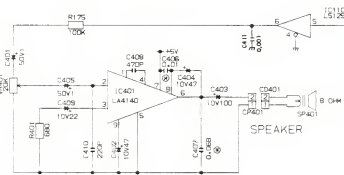
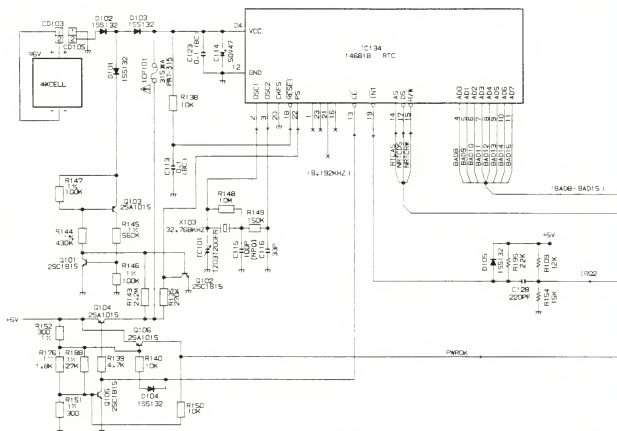

JD501  
POWER IN  
DIN  
4 PIN SOCKET

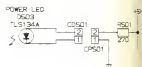
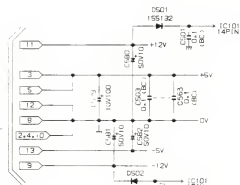

ATTENTION LES PIÈCES MARQUÉES PAR UN ÉTANT DANGEREUSES AN POINT DE VUE SECURITE N UTILISER QUE DELLES DÉCRITES DANS LA NOMENCLATURE DES PIÈCES.

CAUTION SINCE THESE PARTS MARKED BY ARE CRITICAL FOR SAFETY USE ONLY DESCRIBED ON PARTS LIST ONLY.

# CHASSIS SCHEMATIC DIAGRAM

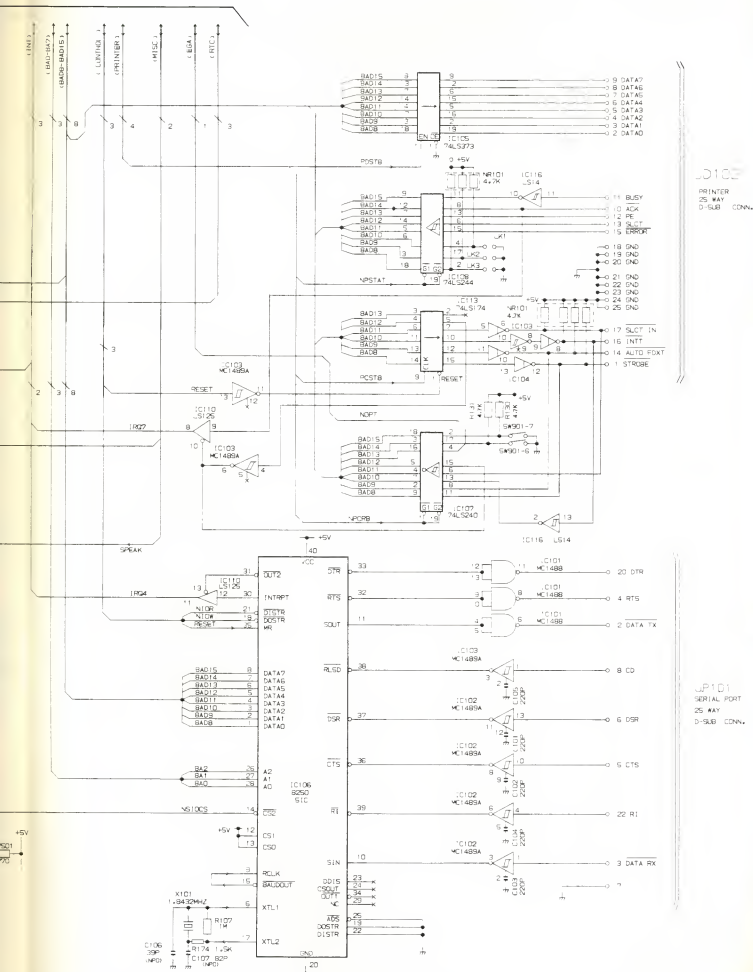

JP102  
 PRINTER  
 25 WAY  
 D-SUB CONN.

JP101  
 SERIAL PORT  
 25 WAY  
 D-SUB CONN.

NOTE THIS SCHEMATIC DIAGRAM IS THE LATEST AT THE TIME OF PRINTING AND SUBJECT TO CHANGE WITHOUT NOTICE.





SCHEMATIC DIAGRAM

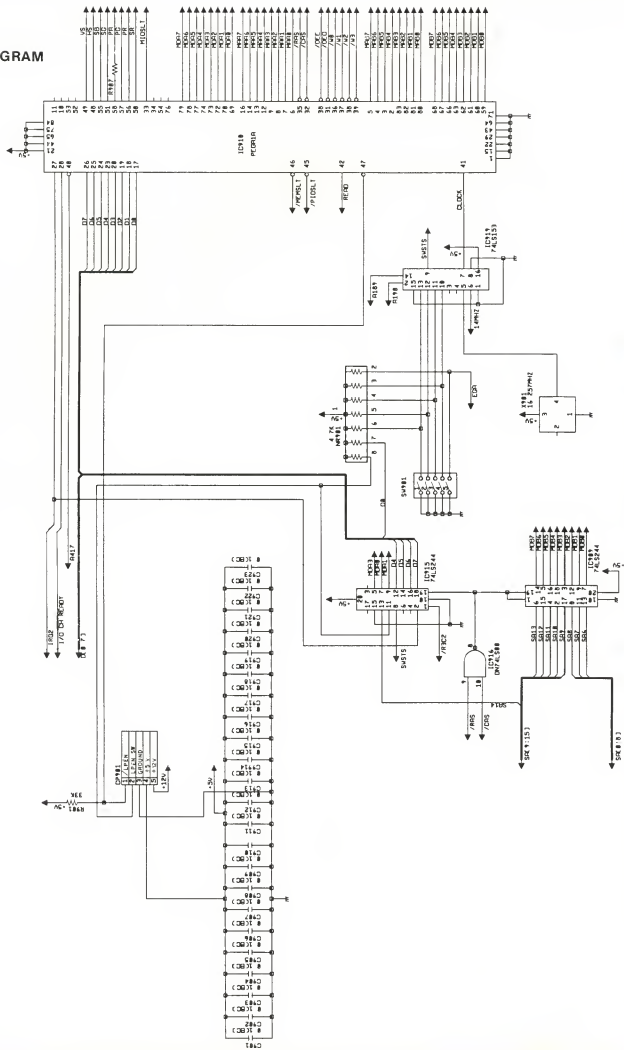

PC1640/SD/DD/HD20 CHASSIS SCHEMATIC DIAGRAM

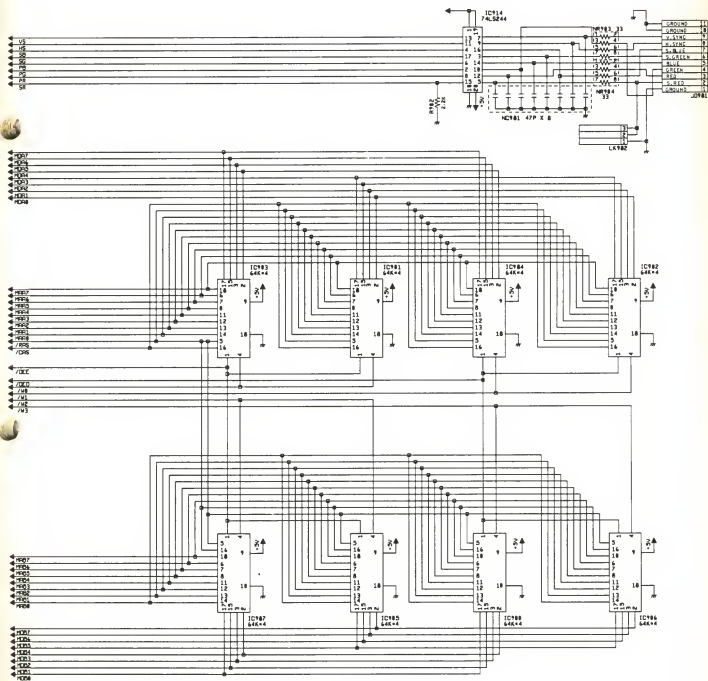

PC-MD ELECTRICAL PARTS LIST

Circ. Ref.	Description	Part No.
<b>Integrated Circuits</b>		
IC201	SN74LS06	175043
IC401	UPC1031H2	171546
IC402	AN5753	171040
IC501	STK7358	△ 171479
IC502	BA6993	171480
IC503	LA6324	170112
IC504	BA707	171481
ICP501, 502	ICP-N50	171547
<b>Transistors</b>		
Q201	TR 2SA733QT	175045
Q403	TR 2SC3173	175046
Q501	TR 2SC3114T-AA	175047
Q502, 518, 519	TR 2SC536KF-NP-AA	50015
Q503, 507, 508, 517	TR 2SA608KF-NP-AA	920113
Q504, 505	TR TLP580Y	171548
Q506, 511, 512, 802	TR 2SC1815Y	170114
Q509, 510, 516	TR 2SD1207-AE	170451
Q513, 515	TR 2SB1134R	171486
Q520	TR 2SA1015Y	170453
Q801	TR 2SC2229Y	170624
<b>Diodes</b>		
D203	D.Z. MTZ5.1BT-77	1422112
D201, 202, 204-207, 402, 408, 409, 512, 513, 517, 520, 525	D.1SS132T-77	171582
D403, 406, 407	D.10ELS4 Diode Rectifier	171550
D404	D.15DF6-FC	175048
D405	D.BB8-FC	175049
D501-504	D.20E10FA13	△ 171048
D505	D.Z.GZB18B	171553
D506	D.DFC15L-KC5	171491
D507	D.Z.GZB9.1B	171493
D508-510	D.DFH10G-KB4	171492
D511	D.Z.GZA18YBT	171554
D514	D.30DF2-FIN	171555
D516	D.F5K060	171496
D518	D.F10P04Q	171497
D521, 524, 802	D.1S2472T-77	175050
D522, 801	D.Z.MTZ5.1BT	1422112
D523	D.Z.MTZ5.6BT	171499
<b>Carbon Film Resistors</b>		
33kohm/¼W	R433	10097
<b>Metal Oxide Resistors</b>		
82ohm/2W	R211	175136
10hm/1W	R413	171069
100ohm/1W	R429	171589
0.33ohm/2W	R504	171072
1kohm/1W	R506	170406
82ohm/1W	R509	171593
56ohm/2W	R511	171588
22kohm/3W	R512	171592
2.2kohm/1W	R513	171591
47ohm/1W	R520	171586
56ohm/1W	R541	171587
0.22ohm/1W	R547-550	171585
8.2kohm/1W	R801	175137
1kohm/2W	R805	175138
<b>Fuse Resistors</b>		
1ohm/½W	R415, 416	171594
10ohm/¼W	R516	809256
39ohm/¼W	R414, 432	171596
1kohm/¼W	R515	171597
<b>Cement Resistors</b>		
5.6ohm/5W	R501	1422138

Description	Circuit Ref.	Part No.
<b>Ceramic Capacitors</b>		
220pF/4kV	C539	170430
0.0022uF/2kV	C502-504, 805, 806	1400223
0.0056uF/500V	C516, 520, 527	171599
0.01uF/1kV	C508	171600
<b>Electrolytic Capacitors</b>		
4.7uF/25V	C4118	175139
22uF/160V	C426	1400243
150uF/400V	C505	171603
330uF/63V	C804	175140
470uF/16V	C522	1400248
1000uF/16V	C517, 521, 530	1400158
2200uF/16V	C402	175141
3300uF/16V	C528, 529	171607
3300uF/35V	C525	171608
<b>Metal Plastic Capacitors</b>		
0.1uF/250V AC	C501	171610
<b>Polypropylene Capacitors</b>		
0.012uF/630V	C424	1751
0.015uF/630V	C421	175125
<b>Almi Electrolytic Capacitors</b>		
EFE222	C549	175126
CFE222	C550	175127
<b>Variable Resistors</b>		
VR201	Volume Rotary Gang 500ohm-10kohm	171611
VR401	VRSF 500ohm	171613
VR402	VR Rotary 30kohm	171614
VR403	VRSF 10kohm	171615
VR404	VRSF 2kohm	171616
VR405	VRSF 100kohm	171617
VR406	VRSF 2.2Mohm	175093
VR407	VRSF 470ohm	175094
VR501	VRSF 5Kohm	171618
VR502-505, 507	VRSF 1 kohm	171619
<b>Switch</b>		
SW501	Power On/Off Switch	△ 171511
<b>Coils &amp; Transformers</b>		
L401	Coil Inductor 100uH 1451MM	171515
L402	Coil Linearity	171558
L403	Coil Width	175095
L501	Coil Line Filter AC	171502
L502	Coil	171560
L503	Coil	171504
L801	Filter Line	171561
T401	Trans Horizontal Drive	171562
T501	Transformer Switching	△ 171563
FB401	Flyback Transformer	171564
<b>P.C. Boards</b>		
PCB001	Monitor PCB MM0027D-C	175052
PCB002	CRT PCB MS0069D	175053
PCB003	Preset PCB MS0070D	175054
<b>Miscellaneous</b>		
CD201	Cord D-Sub	175092
CD502	Cord DIN 14 Pin	175142
DY401	DY	171573
V801	Tube, Cathode ray MN1404H31AU	175091
J801	Jack Socket CRT	171567
F501	Fuse 3.15A (T)	171621

# PC-MD PARTS LIST

## CABINET PARTS LIST

Ref.	Description	Part No.
51	Front Cabinet Assy	175041
52	Holder, PCB (R)	171542
53	Holder, PCB (L)	171541
54	Cabinet Back	175042
55	CRT MN1404H31AU	175091
56	CRT Socket	171567
57	Metal Washer	171580
59	Stand Bottom	171461
60	Stand Top & Spacer	171463
61	Holder Stand	171462
62	Frame Bottom	171543
63	Button Push	171469
64	Knob Volume	171462
65	D-Sub Cord	175092
66	14 Pin DIN Cord	175142

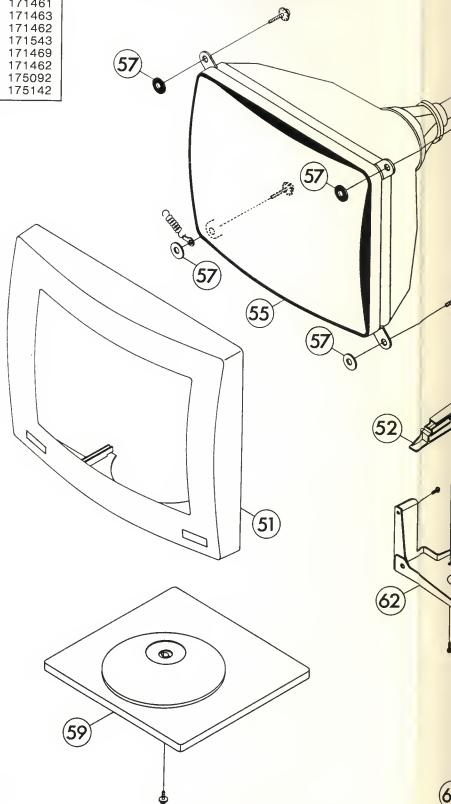

PC/MD CABINET EXPLODED VIEW

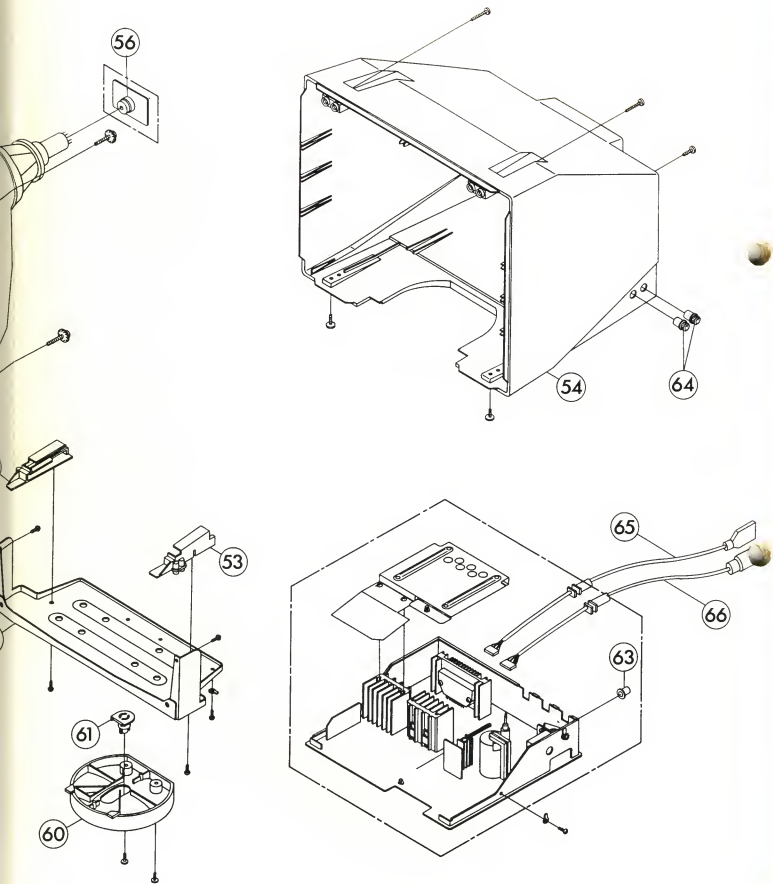



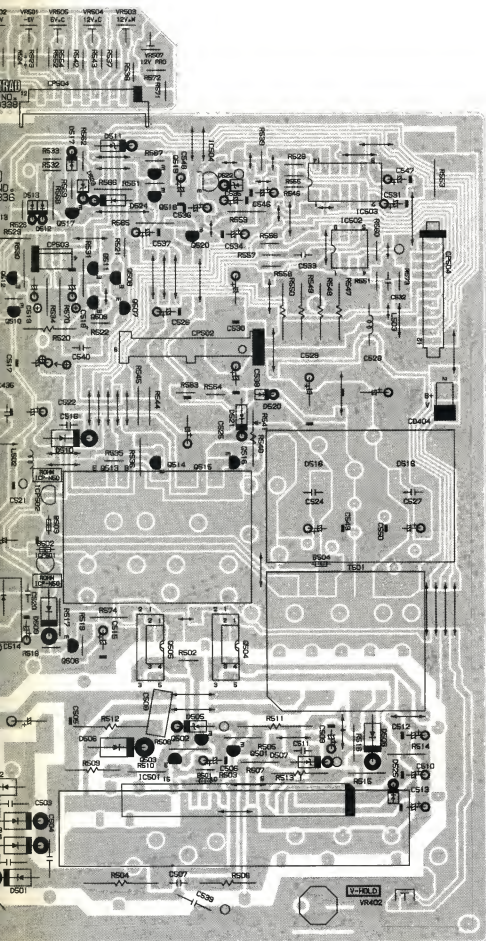



PC/MD CHASSIS SCHEMATIC  
POWER SUPPLY

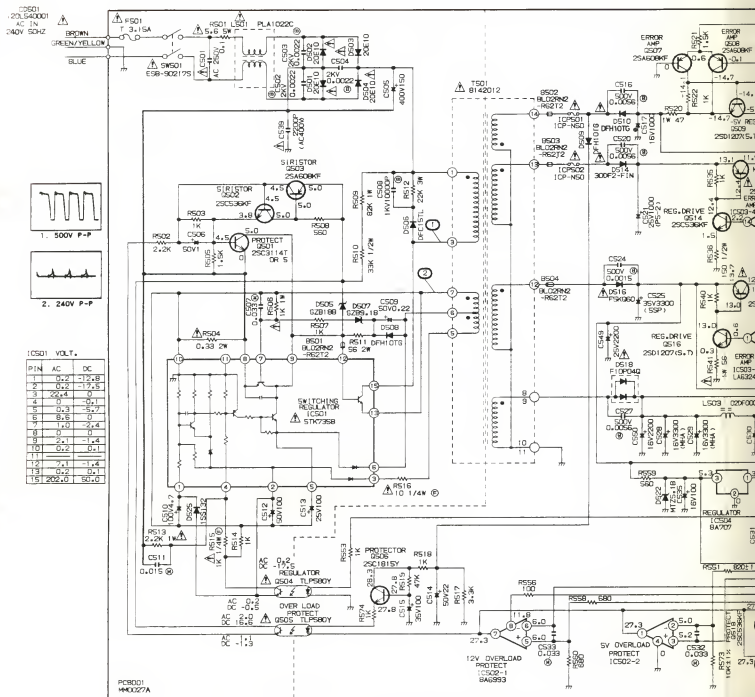

CAUTION: SINCE THESE PARTS MARKED BY  $\Delta$  ARE CRITICAL FOR SAFETY, USE ONES DESCRIBED ON PARTS LIST ONLY.

ATTENTION: LES PIÈCES DANGEREUSES N'UTILISER DANS LA NO

# SCHEMATIC DIAGRAM POWER SUPPLY

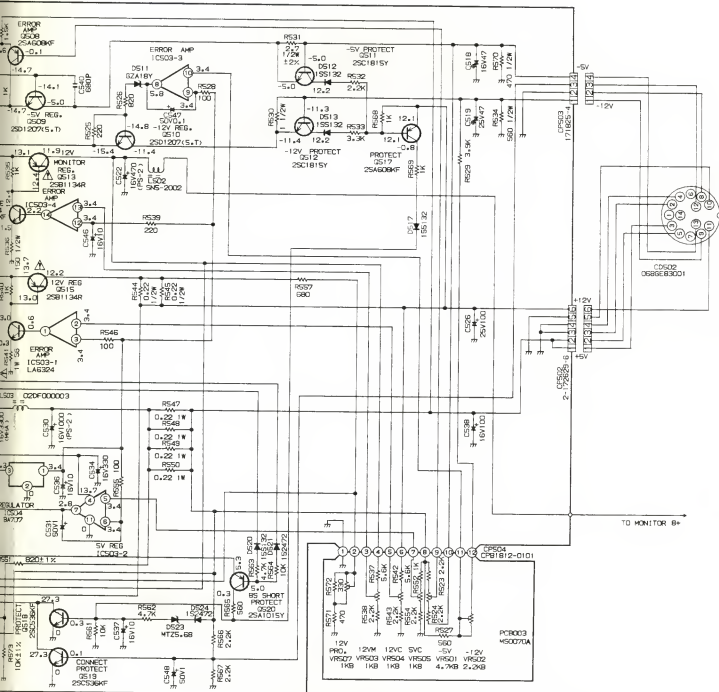

LES PIÈCES RÉPARÉES PAR UN ETANT DANGEREUSES AU POINT DE VUE SECURITE N'UTILISER QUE CELLES DECRITES DANS LA NOMENCLATURE DES PIÈCES.

NOTE THIS SCHEMATIC DIAGRAM IS THE LATEST AT THE TIME OF PRINTING AND SUBJECT TO CHANGE WITHOUT NOTICE.



CAUTION: SINCE THESE PARTS MARKED BY  $\Delta$  ARE CRITICAL FOR SAFETY, USE ONES DESCRIBED ON PARTS LIST ONLY.

ATTENTION: LES PIÈCES RÉPARÉES PAR UN  $\Delta$  ÉTANT DANGEREUSES AN POINT DE VUE SÉCURITÉ N'UTILISER QUE CELLES REÇUES DANS LA NOMÉCLATURE DES PIÈCES.

NOTE: THIS SCHEMATIC DIAGRAM IS THE LATEST AT OF PRINTING AND SUBJECT TO CHANGE WITH

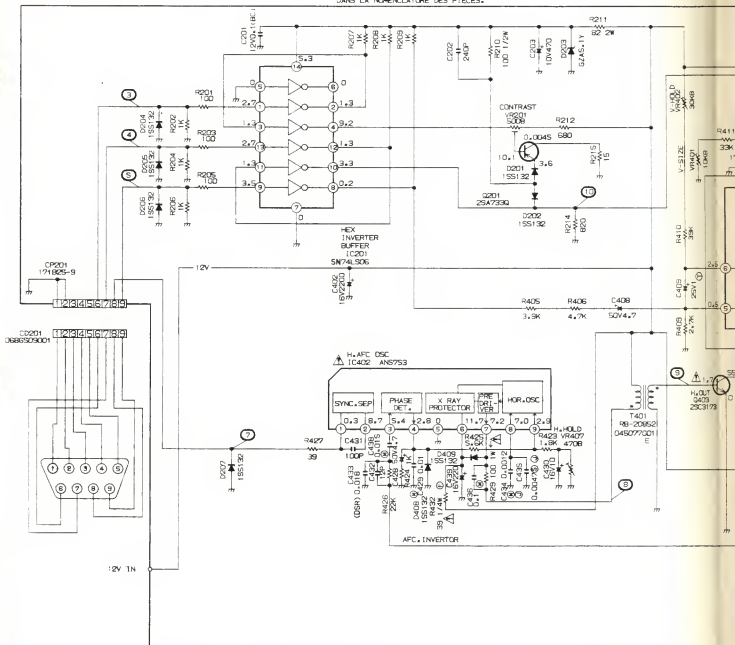

# SCHEMATIC DIAGRAM MONITOR



8. 23V P-P



9. 11V P-P



10. 4.0V P-P



11. 230V P-P



12. 32V P-P

LATEST AT THE TIME  
CHANGE WITHOUT NOTICE.

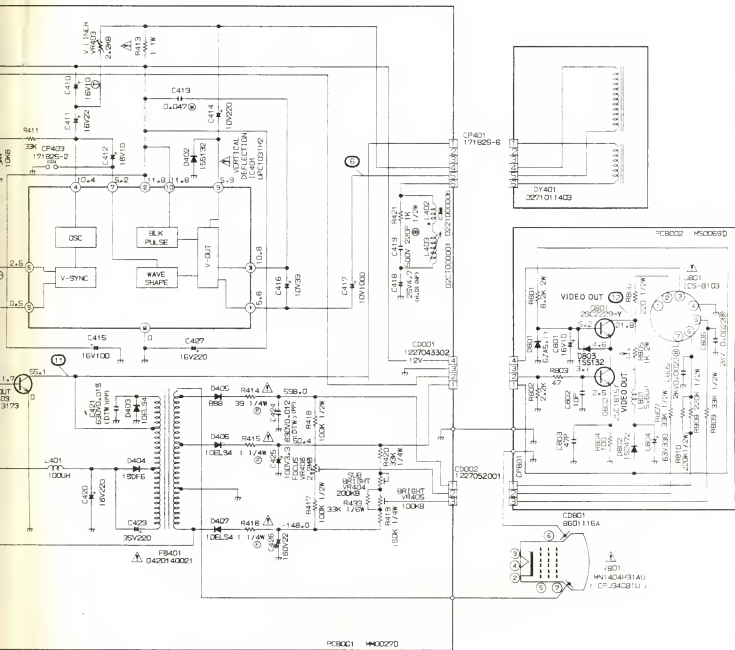

## ALIGNMENT INSTRUCTIONS PC-MD

Equipment required: Digital Multimeter, D.B.O. Scope; Diagnostic Disc/Tool.

Step	FUNCTION	SIGNAL IN	SIGNAL OUT	METHOD	REMARKS
1	To set +5V.	Power supply.	Test point A.	Adjust VR505 to read 5.10V $\pm$ 0.02V.	1. Refer to Fig. A. 2. Prevent short circuit when pulling the PCB forward.
2	To set +12V.	Power supply.	Test point B.	Adjust VR504 to read 12.15V $\pm$ 0.02V.	1. Refer to Fig. A. 2. Prevent short circuit when pulling PCB forward.
3	To set -5V.	Power supply.	Test point C.	Adjust VR501 to read 5V $\pm$ 0.05V.	1. Refer to Fig. A. 2. Prevent short circuit when pulling the PCB forward.
4	To set -12V.	Power supply.	Test point D.	Adjust VR502 to read 12.0V $\pm$ 0.05V.	1. Refer to Fig. A. 2. Prevent short circuit when pulling the PCB forward.
5	To set protect adjustment.	Power supply.	Pin 11 of 14 pin DIN plug	Adjust VR507 to read 4.5A on the ammeter in series with load.	1. Refer to Fig. A. 2. Prevent short circuit when pulling the PCB forward.
6	To set +12V for monitor.	Power supply.	Test point E.	Adjust VR503 to read 12.0V $\pm$ 0.05V.	1. Refer to Fig. A. 2. Prevent short circuit when pulling the PCB forward.
7	Centering the screen.	Screen on.	Observe the screen.	Load HGC test pattern from the floppy disc in the system unit. Set brightness and contrast pots to max ie VR405 & VR201 turn centering magnet to adjust circle pattern in H position. Adjust L403 to get border see Fig. Then adjust 4 pole magnet to clear any corner distortion.	1. Refer to Fig. B
8	V size cont.	Screen on.	Observe screen.	Use the same test screen as 7. Adjust VR401 to make A=C, B=D & E+F=174 $\pm$ 2mm.	1. Refer to Fig. B
9	V. Linearity adjustment.	Screen on.	Observe screen.	Use the same screen as 7. Adjust VR403 to make E=F. Check corner circles to be circles.	1. Refer to Fig. B
	Free run frequency adjustment.	Screen on.	Monitor frequency counter.	Set VR407 to read frequency be 18.432kHz. Connect frequency counter to DY red wire.	1. Remove D sub cable from system unit.
11.	Sub Brightness adjustment.	Screen on.	Observe screen	Set test screen as 7. Fit a link across CP403. The picture will squash. Adjust VR404 to thin it further. Remove link.	1. Remove link after the test.
12.	Focus adjustment.	Screen on	Observe screen.	Use HGC test from F.D. Select RCC pattern. Set VR405 & VR201 to max. Adjust VR406 to get letters in all 4 corners same	

### MAJOR COMPONENTS LOCATION GUIDE

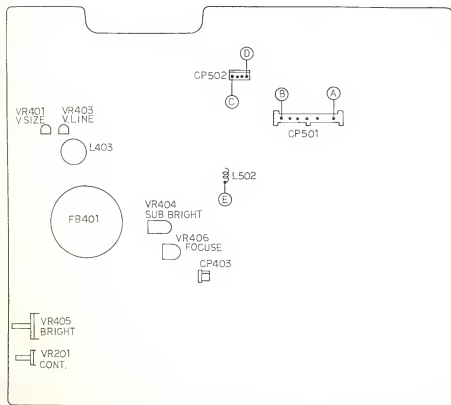

Figure A

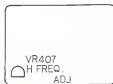

Figure A

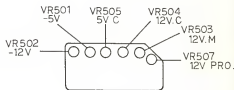

Figure A



Figure B

PC-CD ELECTRICAL PARTS LIST

Ref.	Description	Part No.
<b>Integrated Circuits</b>		
IC101	IC OEC9001	171477
IC102	IC TC74HC02P	171622
IC401	IC UPC1378H	170444/A
IC402	IC LA7820	1400368
IC501	IC STK7356	171478
IC502	IC L78M12	190062
IC503	IC L78M05	190731
IC601	IC STK7358	171479
IC602	IC BA6993	171480
IC603	IC LA6324	170112
IC604	IC BA707	171481
ICP501, 502	ICP-N75	171057
ICP053	ICP PFR-315-F003	171483
ICP601	ICP-N50	171547
<b>Transistors</b>		
Q101-103, 105-113, 401, 601, 602, 610-612, 616, 618, 801-803	TR 2SC1815	170447
Q104, 402, 603, 606, 607, 613, 617	TR 2SA1015	170453
Q403	TR 2SD1426	171484
Q404	TR 2SC2271	170449
Q604, 605	TR TLP580	171485
Q608, 609, 615	TR 2SD1207-T	170451
Q614	TR 2SB1134R	171486
Q804-806	TR 2SC3789	171487
<b>Diodes</b>		
D101-105	D.Z. MTZ6.8BT-77	171488
D106-115, 401-405, 407-409, 505, 608, 609, 613, 616-620	D. ISS132T-77	171489
D406, 412, 413, 610	D. DFD05G	171490
D410	D.Z. MTZ11BT	171623
D411	D.BB4-FC	1422116
D501-504	D. 20E10FFA13	170848
D506, 603	D. DFC15L-KC5	171491
D507, 509, 604-606	D. DFH10G-KB4	171492
D508, 602	D.Z. GZB9.1B	171493
D510	D. 30DF6-FC	171494
D511	D.Z. SR-2M	1400122
D601	D.Z. GZB18B	171495
D607	D. GZA18Y	171624
D611	D.Z. FSK060	171496
D612	D.Z. F10PO4Q	171497
D614	D.Z. MTZ5.1BT-77	171498
D615	D.Z. MTZ5.6BT-77	171499

Description	Ref.	Part No.
<b>Metal Oxide Resistors</b>		
0.22ohm/1/8W	R643-646	171625
0.33ohm/2W	R604	171072
1ohm/3W	R502	171077
4.7ohm/3W	R438	171626
15ohm/2W	R511	171627
47ohm/1W	R624	171628
56ohm/1W	R637	171629
68ohm/2W	R512	171630
82ohm/2W	R507	175113
100ohm/2W	R612	171631
1kohm/1W	R610	170406
2.2kohm/1W	R613	171632
3.3kohm/1W	R504	171633
3.9kohm/1W	R503	170407
4.7kohm/2W	R434	171634
5.6kohm/2W	R805-807	171635
22kohm/3W	R609	171636
33kohm/2W	R508	171637
82kohm/1W	R607	171638
<b>Fuse Resistors</b>		
0.82ohm/1W	R442	1422141
1ohm/1/8W	R443	171639
8.2ohm/1/4W	R437	170404
10ohm/1/4W	R510, 616	809256
100ohm/1/4W	R412	171640
100ohm/1/2W	R147, 444	1400183
470ohm/1/2W	R509	171641
1kohm/1/4W	R614	171642

Reference	Description	Part No.
<b>Cement Resistor</b>		
5.6ohm/5W	R501, 601	1422138
<b>Variable Resistors</b>		
VR101, 103	VRSF 1kohm	171691
VR102	VR Rotary 500ohm-500ohm	171692
VR104	VRSF 2kohm	171616
VR401	VR Rotary 200kohm	171693
VR402	VRSF 5kohm	171694
VR403	VRSF 5kohm	171695
VR404	VRSF 500ohm	171612
VR601	VRSF 5kohm	171618
VR602-604, 606	VRSF 1kohm	171619
VR801	VRSF 5kohm Red	171696
VR802	VRSF 5kohm Green	171697
VR803	VRSF 5kohm Blue	171698
VR804	VRSF 500ohm Red	171699
VR805	VRSF 500ohm Blue	171700
<b>Ceramic Capacitors</b>		
270pF/2kV	C429	170429
820pF/2kV	C523	171643
2200pF/4kV	C505	170430
0.01uF/2kV	C801	1422147
0.0015uF/500V	C620	171644
0.0015uF/2kV	C511, 514, 807	171645
0.0022uF/2kV	C502-504, 604	1400223
0.0056uF/500V	C612, 617	171646
<b>Polyester Capacitors</b>		
0.1uF/100V	C404	1400237
<b>Electrolytic Capacitors</b>		
22uF/250V	C436	171649
150uF/400V	C506, 601	171650
220uF/160V	C515	171651
470uF/35V	C516	171653
1000uF/16V	C623	1422158
1000uF/35V	C437	1422159
2200uF/35V	C408	1422160
3300uF/16V	C621, 622	171654
3300uF/35V	C618	171655
<b>Metal Polypropylene Capacitors</b>		
0.0082uF/1.6kV	C430	171656
0.82uF/200V	C433	171657

Ref	Description	Part No.
<b>Metal Plastic Capacitors</b>		
0.1uF/250V AC	C501	171658
<b>Polypropylene Capacitors</b>		
0.1uF/200V	C439	171609
<b>Coils &amp; Transformers</b>		
L401	Coil Linearity	171500
L402	Coil RX-9P-472K 470uH	171501
L501	Coil Line Filter AC PLA1022C	△171502
L502	Coil Degauss	171503
L601	Coil	171504
L801-804	Coil EL0606RA-101K	171505
T401	Trans, Horizontal Drive	△171506
T501	Transformer, Switching	△171507
T601	Transformer Switching	△171508
FB401	Transformer Flyback	171509
	3714013	
<b>Switches</b>		
SW401	Switch Slide	△171510
SW501	Switch Push	△171511
<b>P.C. Boards</b>		
PCB001	PCB MM0030A Monitor Main	175096
PCB002	PCB MS0054A CRT Socket/Colour Drive	171513
<b>Jack</b>		
J801	Socket, CRT	171514
JC801	Socket Cover CRT	171515
<b>Miscellaneous</b>		
CD101	Cord DIN 14 Pin	171519
CD601	Cord D-Sub 9 Pin	175087
F501	Fuse S506 3.15A (T)	171531
TH501	Degauss Element	△171533
V801	Tube, Cathode Ray	171534
	M34EAQ10X-AT1460/90	
ICP501, 502	ICP-N75	171057
ICP503	ICP PRF-315-F003	171483
ICP601	ICP-N50	171547

## ALIGNMENT INSTRUCTIONS PC-CD

Equipment required: Digital Multimeter; D.B.O. Scope; Diagnostic Disc/Tool.

Step	FUNCTION	SIGNAL IN	SIGNAL OUT	METHOD	REMARKS
1	To set +5V.	Power supply.	Test point A.	Adjust VR604 to read 5.10V $\pm 0.02V$	1. Refer to Fig. A 2. Prevent short circuit when pulling the PCB forward.
2	To set +12V.	Signal in power supply.	Test point B	Adjust VR603 to read 12.15V $\pm 0.02V$	1. Refer to Fig. A 2. Prevent short circuit when pulling the PCB forward.
3	To set -5V.	Signal in power supply.	Test point C.	Adjust VR601 to read 5V $\pm 0.05V$	1. Refer to Fig. A 2. Prevent short circuit when pulling the PCB forward.
4	To set -12V	Signal in power supply.	Test point D	Adjust VR602 to read 12.0V $\pm 0.05V$	1. Refer to Fig. A 2. Prevent short circuit when pulling the PCB forward.
5	To set protect adjustment.	Signal in power supply	+12V line.	Adjust VR606 to read 4.5A on the ammeter in series with load	1. Refer to Fig. A. 2. Prevent short circuit when pulling the PCB forward.
6	V. size setting	Load diagnostics in PC1640	Monitor screen.	Adjust VR404 to the border is 12mm $\pm 3$ mm all around.	1. Set optimum brightness & contrast setting 2. Refer to Fig. 1.
7	Sub contrast control	Load diagnostics in PC1640.	Monitor screen.	Select colour bar pattern set brightness pot VR102-2 to max & contrast pot VR102-1 to min. Adjust VR103 so the intensity colour is marginally coloured	
8	Grey level adjustment	Load diagnostics in PC1640	Monitor screen.	Select same test as 7. Connect O'scope to Q802 collector see wave form set VR102-2 to max. Adjust VR101 to get 35% grey as white be 100% against black	1. Refer to Fig. 2
9	Sub H. Hold control	From IC402 Pin 4.	Scope Pin 4 of IC402	Set VR403 to mid position. Adjust VR402 to read frequency 15.625KHz.	

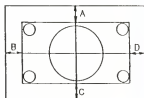
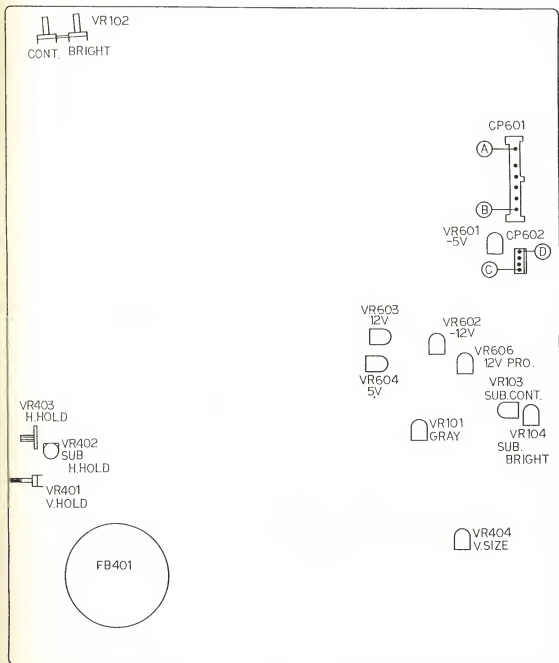

Figure 1

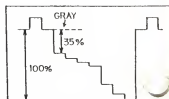
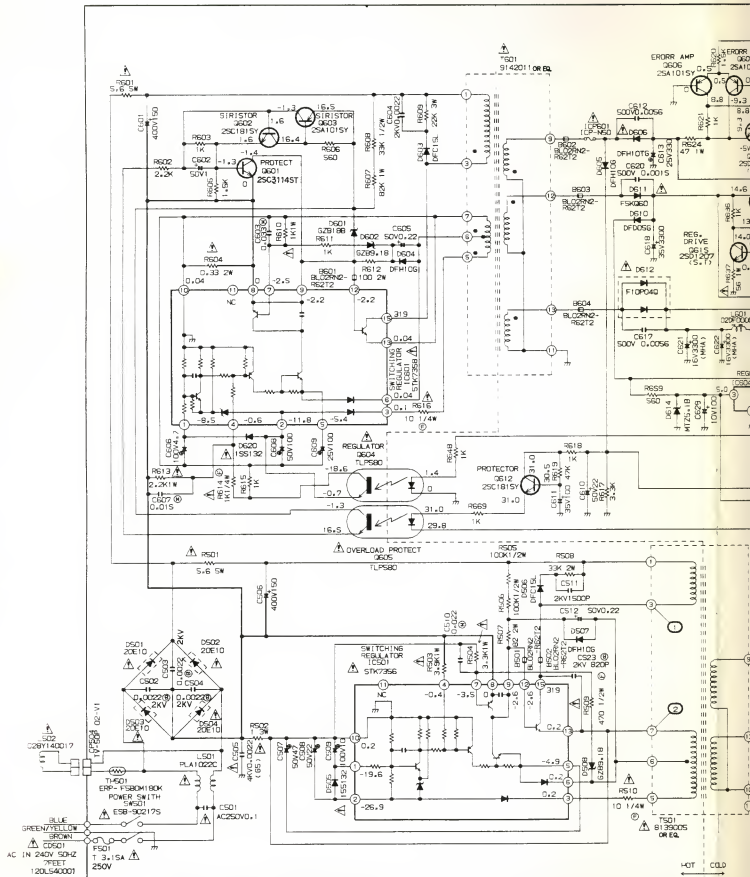

Figure 2

Figure A



PC/CD CHASSIS SCHEMATIC  
POWER SUPPLY



ATTENTION LES PIÈCES RÉPARÉES PAR UN  $\Delta$  ETANT DANGEREUSES AN POINT DE VUE SECURITE N UTILISER QUE CELLES IDENTIFIES DANS LA NOMENCLATURE DES PIÈCES.

CAUTION SINCE THESE PARTS MARKED BY  $\Delta$  ARE CRITICAL FOR SAFETY USE ONES DESCRIBED ON PARTS LIST ONLY.

# SCHEMATIC DIAGRAM POWER SUPPLY

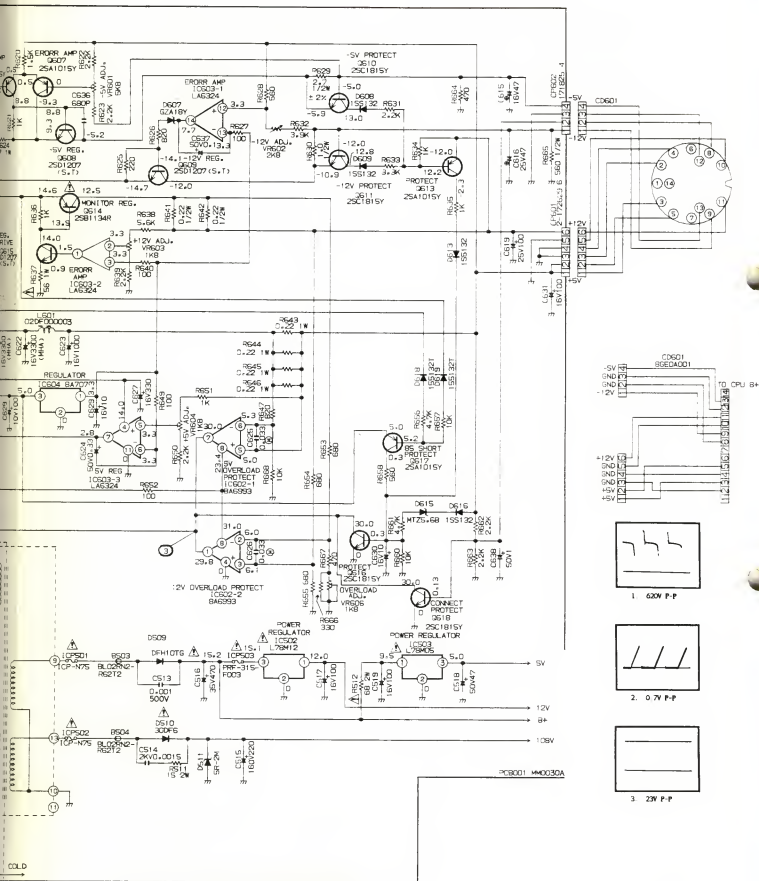

NOTE THIS SCHEMATIC DIAGRAM IS THE LATEST AT THE TIME OF PRINTING AND SUBJECT TO CHANGE WITHOUT NOTICE.

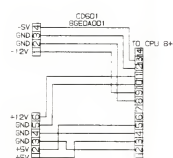

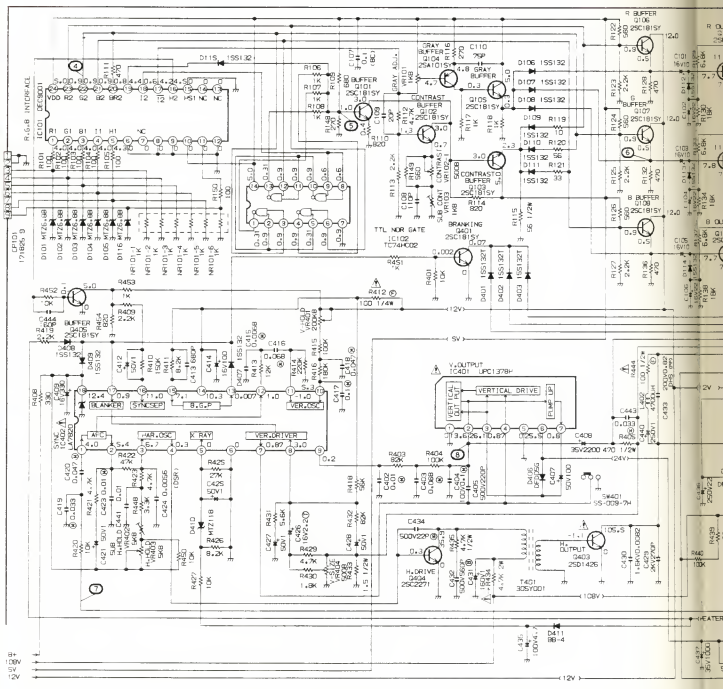

CAUTION: SINCE THESE PARTS MARKED BY  $\Delta$  ARE CRITICAL FOR SAFETY, USE ONES DESCRIBED IN PARTS LIST ONLY.

ATTENTION: LES PIÈCES RÉPARÉES PAR UN  $\Delta$  ÉTANT CLASSIFIÉES EN UN POINT DE VUE SÉCURITÉ, N'UTILISER QUE CELLES DÉCRITES DANS LA NOMÉCLATURE DES PIÈCES.

NOTE THIS SCHEMATIC IS FOR INFORMATION ONLY.



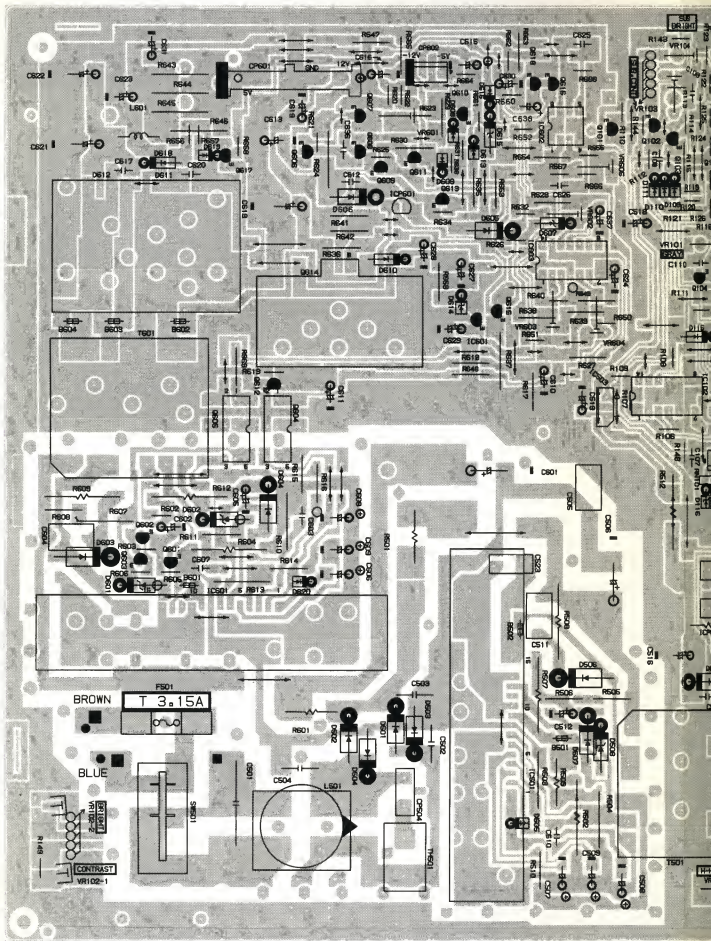

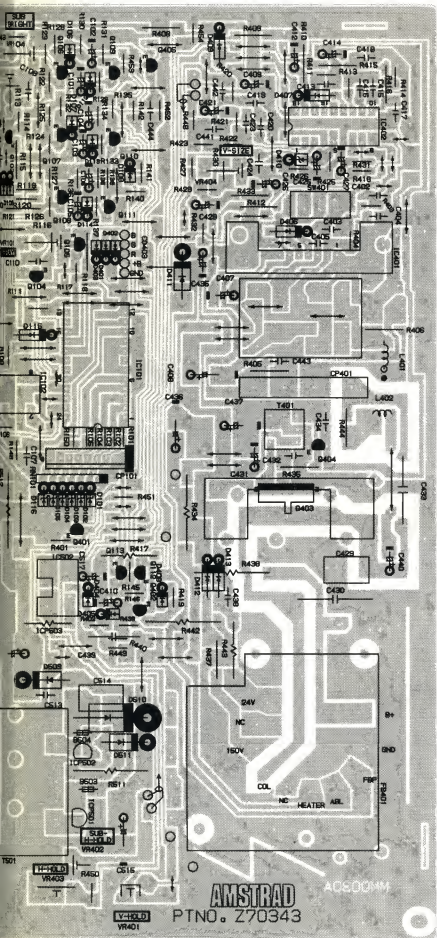

PC/CD CRT P.C. BOARD

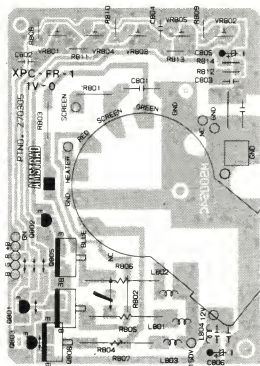

PC-ECD CABINET PARTS LIST

Ref.	Description	Part No.
71	Cabinet Front Assy	175057
72	Stand Bottom	171461
73	Stand Top	171463
74	Holder Stand	171462
75	Holder PCB (R)	171466
76	Holder PCB (L)	171465
77	Frame Bottom	171464
78	Button Push	171469
79	Knob Volume	171362
80	Cabinet Back	175058
81	CRT M34JKD97*77	175097
82	Sheet CRT Spacer	
83	Screw Tape Tite Pan	
84	Degauss Coil	171503
85	CRT Socket	175108
86	D-Sub Cord	175143
87	14 Pin DIN Cord	171522
88	Fan Unit	96001
	Frame PCB	171467
	Bracket Switch	171468

PC-CD/PC-ECD C

PC-CD CABINET PARTS LIST

Ref.	Description	Part No.
31	Cabinet Front Assy	175044
32	Stand Bottom	171461
33	Stand Top	171463
34	Holder Stand	171462
35	Holder PCB (R)	171466
36	Holder PCB (L)	171465
37	Frame, Button	171464
38	Button Push	171469
39	Knob Volume	171362
40	Cabinet Back	171474
41	CRT M34EAQ10X-AT1460/90	171534
42	Sheet CRT Spacer	
43	Screw Tap Tite Pan GW22	
44	Degauss Coil	171503
45	CRT Socket	171514
48	D-Sub Cord	175087
49	14 Pin DIN Cord	171522
	Frame PCB	171467
	Bracket Switch	171468
	Card Spacer	171471
	Spring CRT Earth	171475
	Mini Card Spacer	171476

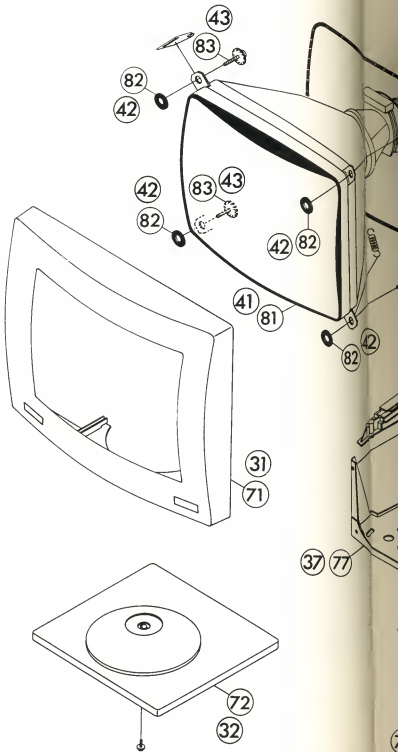

PC-CABINET EXPLODED VIEW

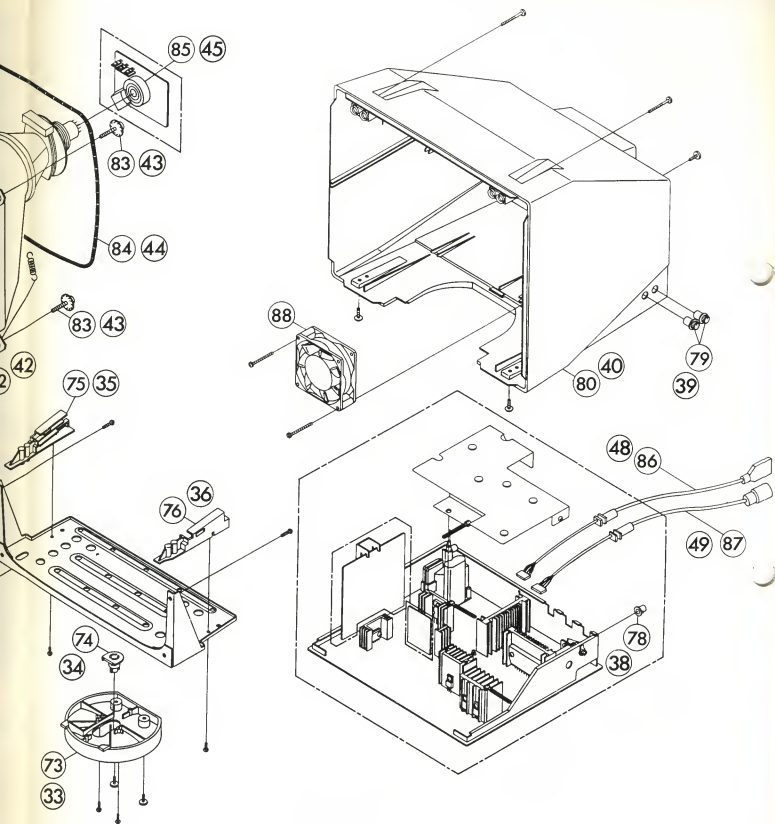



Ref.	Description	Part No.
<b>I.C.s</b>		
IC101	IC M5236L	171477
IC102	IC LC74HC86	175070
IC103	IC DN74LS20	175071
IC104, 105	IC DN74LS08	40011
IC106-110	IC DN74LS38	40019
IC111	IC M5223P	175072
IC401	IC LA7850	175073
IC402	IC UPC1378H	170444/A
IC501	IC STK7356	171478
IC502	IC L78M12	190062
IC503	IC BA17805	175074
IC504	IC L78M08	175075
IC601	IC STK7358	171479
IC602	IC BA6993	171480
IC603	IC LA6324	170112
IC604	IC BA707	171481
<b>Transistors</b>		
Q101, 103	TR 2SB632E	175076
Q102, 113-115, 406, 418, 603, 606, 607, 613, 617	TR 2SA1015Y	170453
Q104-106, 401- 405, 408, 412- 417, 602, 610- 612, 616, 618, 801-803	TR 2SC1815Y	170447
Q107, 109	TR DTA144E S-T	152042
Q108, 110, 112	TR DTC144E S-T	175098
Q111	TR DTC114E S-T	175099
Q804-806	TR 2SC3790	175080
<b>Diodes</b>		
D101-110, 121, 122, 401, 402, 410-412, 414, 417, 418, 420- 425, 429, 430, 432, 505, 608, 609, 613, 616, 618-620	D ISS132T-77	171489
D434, 801-803	D ISS132	175100
D113-120	D Zener MTZ6.8BT-77	171488
D403, 416	D MTZ30BT-77	175066
D405	D MTZ11BT-77	171623
D406, 419, 426, 610	D DFD05TG-BT	175067
D407	D BB4-FG	1422116
D408, 409	D 11E1TA1-T	171551
D433, 615	D MTZ5.6BT-77	171499
D435, 436	D DFC05R	175069
D501-504	D 20E10FA13	170848
D506, 603	D DFC15TL-KC5	171491
D507	D DFH10TG-KB4	171492
D508	D GZA9.1B	171493
D509, 604-606	D DFH10TG-KB4	171492
D510	D 30DF6 FC	171494
D511	D Avalanch SR-2M	1400122
D601	D GZA18B	171495
D602	D BZA9.1B	171493
D607	D Zener GZA18Y BT	171624
D611	D F5KQ60	171496
D612	D F10PO4Q	171497
D614	D MTZ5.1BT-77	171498

Ref	Description
<b>Coils</b>	
L401	Coil Linearity
L402	Coil Width
L501	Coil Line Filter
L502	Coil Degauss
L601	Coil Choke
L801-804	Coil 100uH
T401	TX Horizontal
T402	TX Pin Cushion
T501	TX Switching
T601	TX Switching
<b>Variable Resistors</b>	
VR102	VR Rotary
VR103	VRSF 1kohm
VR105, 106	VRSF 220ohm
VR401	VR Rotary 20
VR402, 403	VRSF 470ohm
VR404	VRSF 4.7kohm
VR405	VRSF 5kohm
VR406, 408	VRSF 10kohm
VR601	VRSF 5kohm
VR602	VRSF 2kohm
VR603, 604, 606	VRSF 1kohm
VR801	VRSF 5kohm
VR802	VRSF 5kohm
VR803	VRSF 5kohm
VR804	VRSF 500ohm
VR805	VRSF 500ohm
<b>PCB Assemblies</b>	
PCB001	Main Monitor
PCB002	EGA PCB Ass
PCB003	CRT PCB Ass
PCB004	Relay PCB Ass
<b>Miscellaneous</b>	
CD101	D-Sub 9 Way
CD601	DIN Cord 14
FB401	Flyback Tran
ICP501	IC Protector
ICP502	IC Protector
ICP503	IC Protector
ICP505	IC Protector
ICP601	IC Protector
M501	Fan EGA Mo
MC001	Mica Sheet
NR101	Resistor Netw
RY401, 402	Relay G6B-1
TH501	Degauss Ele
V801	CRT N34JK
J801	Socket CRT
SW401	Slide Switch
SW501	Push Switch
F501	Fuse 3.15A
<b>Carbon Film Resistors</b>	
100ohm	R416
6.8kohm	R817-819

**CTRICAL PARTS LIST**

Description	Part No.
oil Linearity ELH-5L177N	171500
oil Width	175101
oil Line Filter AC 1022C	171502
oil Degauss	171503
oil Choqe	171504
oil 100uH	171505
oil Horizontal Drive	171506
oil Pin Cushion	175102
oil Switching 006	175081
oil Switching 011	171508
oil Rotary	171692
oil RSF 1kohm	171691
oil RSF 220ohm	175102
oil Rotary 200kohm	171693
oil RSF 470ohm	175121
oil RSF 4.7kohm	175120
oil RSF 5kohm	175122
oil RSF 10kohm	175123
oil RSF 5kohm	175124
oil RSF 2kohm	171616
oil RSF 1kohm	171619
oil RSF 5kohm Red	171696
oil RSF 5kohm Green	171697
oil RSF 5kohm Blue	171698
oil RSF 500ohm Red	171699
oil RSF 500ohm Blue	171700
oil Main Monitor PCB Assy	175083
oil GA PCB Assy	175084
oil RT PCB Assy	175085
oil Delay PCB Assy	175086
oil Sub 9 Way Connector	175143
oil N Cord 14 Way	171522
oil Flyback Transformer	175082
oil Protector F4000	175103
oil Protector N75T104	171075
oil Protector PRF-630	175104
oil Protector PRF-400	175105
oil Protector N50	171547
oil InEGA Monitor	96001
oil mica Sheet	175119
oil Resistor Network 6 x 1kohm	175106
oil Delay G6B-114P-FD	175107
oil Degauss Element	171533
oil RT M34JKD97*77	175097
oil Socket CRT	175108
oil Slide Switch Service-Normal	171510
oil Push Switch Power On/Off	171511
oil Case 3.15A (T)	171531
oil rs	
oil 16	10032
oil 17-819	10081

Description	Circuit Reference	Part No.
<b>Metal Oxide Resistors</b>		
0.22ohm/1W	R643-646	175117
0.33ohm/2W	R604	171072
1ohm/2W	R502	171077
4.7ohm/3W	R456	171626
47ohm/1W	R624	171628
56ohm/1W	R637	171629
100ohm/2W	R612	171631
15ohm/2W	R511, 513	171627
68ohm/2W	R436	171630
82ohm/2W	R507	175113
1kohm/1W	R610	170406
2.2kohm/1W	R613	171632
2.2kohm/2W	R442	175114
3.7kohm/2W	R452	175109
3.9kohm/1W	R503, 504	170407
4.7kohm/3W	R499	175115
5.6kohm/2W	R805-807	171635
22kohm/3W	R609	171636
33kohm/2W	R508	171637
82kohm/1W	R607	171638
<b>Fuse Type Resistors</b>		
1ohm/1/2W	R458	171639
1.2ohm/1W	R457	175110
8.2ohm/1/2W	R455	170404
10ohm/1/4W	R510, 616	809256
22ohm/1/4W	R459	175111
33ohm/1/2W	R512	175112
47ohm/1/2W	R509	171641
1kohm/1/4W	R614	171642
<b>Cement Resistors</b>		
5.6ohm/5W	R501	1422138
<b>Electrolytic Capacitors</b>		
2.2uF/50V	C465	175144
4.7uF/100V	C429	175116
22uF/250V	C440	171649
150uF/400V	C506, 601	171450
220uF/160V	C515	171651
330uF/25V	C613	171652
470uF/35V	C516	171653
1000uF/16V	C457, 623	1422158
1000uF/35V	C441	1422159
2000uF/35V	C427	1422160
3300uF/16V	C621, 622	171654
3300uF/35V	C618	171655
<b>Ceramic Capacitors</b>		
39pF/50V	C807-809	1400207
180pF/2kV	C438	175145
220pF/2kV	C456	175146
680pF/500V	C435	1400213
820pF/2kV	C523	171643
2200pF/125V	C505	175147
0.001uF/2kV	C801	1422147
0.0015uF/2kV	C511, 514	171645
0.0022uF/2kV	C439, 502-504, 604	1400223
0.0056uF/500V	C612, 617	171646
<b>Polypropylene Capacitors</b>		
0.1uF/200V	C430, 445	1400237
<b>Metal Plastic Capacitors</b>		
0.1uF/250V AC	C501	171658
<b>Metal Polypropylene Capacitors</b>		
2200pF/1.6kV	C437	175118

## ALIGNMENT INSTRUCTIONS PC-ECD

Equipment required: Digital multimeter; D.B.O. Scope, Diagnostic Disc/Tool.

Step	FUNCTION	SIGNAL IN	SIGNAL OUT	METHOD	REMARKS
1.	To set +5V.	Power supply.	Test point A	Adjust VR604 to read 5 10V $\pm 0.02V$	1 Refer to Fig. A 2. Prevent short circuit when pulling the PCB forward
2.	To set +12V.	Power supply.	Test point B	Adjust VR603 to read 12 15V $\pm 0.02V$	1 Refer to Fig. A 2. Prevent short circuit when pulling the PCB forward
3.	To set -5V.	Power supply.	Test point C	Adjust VR601 to read 5V $\pm 0.05V$ .	1 Refer to Fig. A 2. Prevent short circuit when pulling the PCB forward
4.	To set -12V	Power supply.	Test point D	Adjust VR602 to read 12 0v $\pm 0.05V$ .	1 Refer to Fig. A 2. Prevent short circuit when pulling the PCB forward
5.	To set protect adjustment.	Power supply	+12V line.	Adjust VR606 to read 4.5A on the ammeter in series with load	1 Refer to Fig. A 2. Prevent short circuit when pulling the PCB forward
6.	V. size setting position set.	Load diagnostics in PC1640.	Monitor screen.	Select circle crosshatch pattern (15kHz) Adjust VR408 & VR403 so B.D & A.C becomes 12mm $\pm 3$ mm respectively. Select pattern as before (22kHz) Adjust VR406 & VR402 for similar measurements. If in previous case, B.D do not become 12 $\pm 3$ mm adjust L402 the setting will be for 15kHz	1. Set optimum brightness & contrast setting 2. Refer to Fig. 2
7.	Sub contrast Sub brightness control.	Load EFG diag test card	Monitor screen.	Primary colour pattern. Set VR102-1 & 2 to max. Scope Q802 base match Match A&B wave forms with VR103, make C to be 4.5V with VR105. Get circle pattern on the screen monitor +ve of C450 to read 4.5V with VR106	1 Refer Fig. 1
8.	Focus adjustment.	Character pattern.	Monitor screen.	Turn focus control fully clockwise then turn anti clockwise to adjust focus.	
9.	Sub H. Hold control	From IC402 pin 4.	Scope pin 5 of FB401.	Set VR405 to mid position. Adjust VR404 to read frequency 22kHz.	

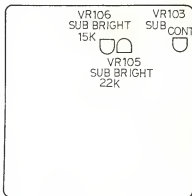
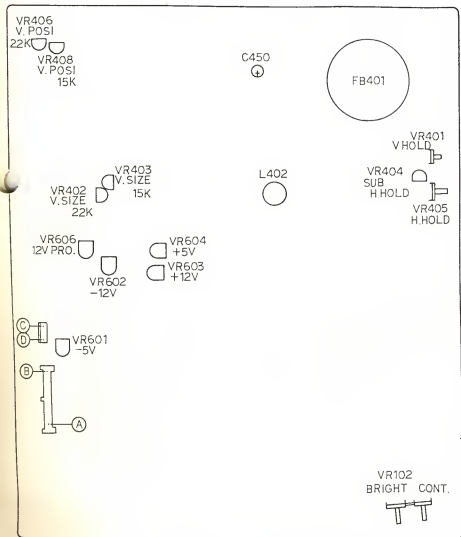

Figure A

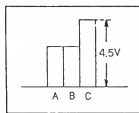

Figure 1

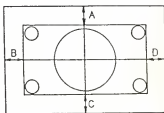
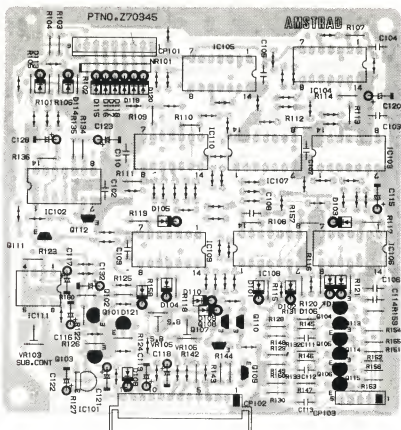

Figure 2

PC/ECD RGB P.C. BOARD



PC/ECD CRT P.C. BOARD

PC/ECD RELAY P.C. BOARD

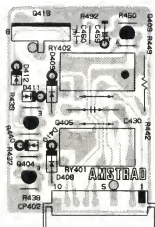
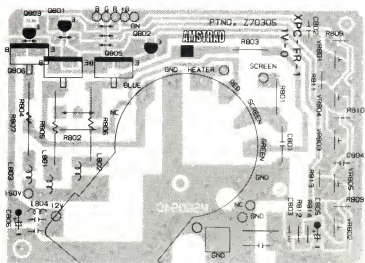





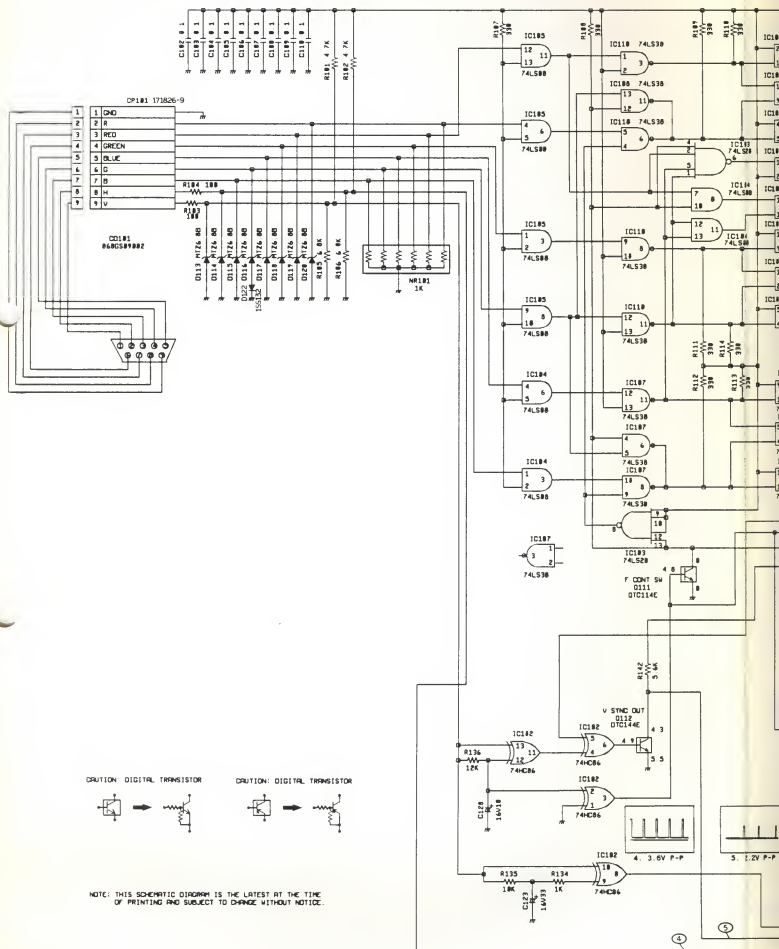

SCHEMATIC DIAGRAM  
VIDEO DECODER

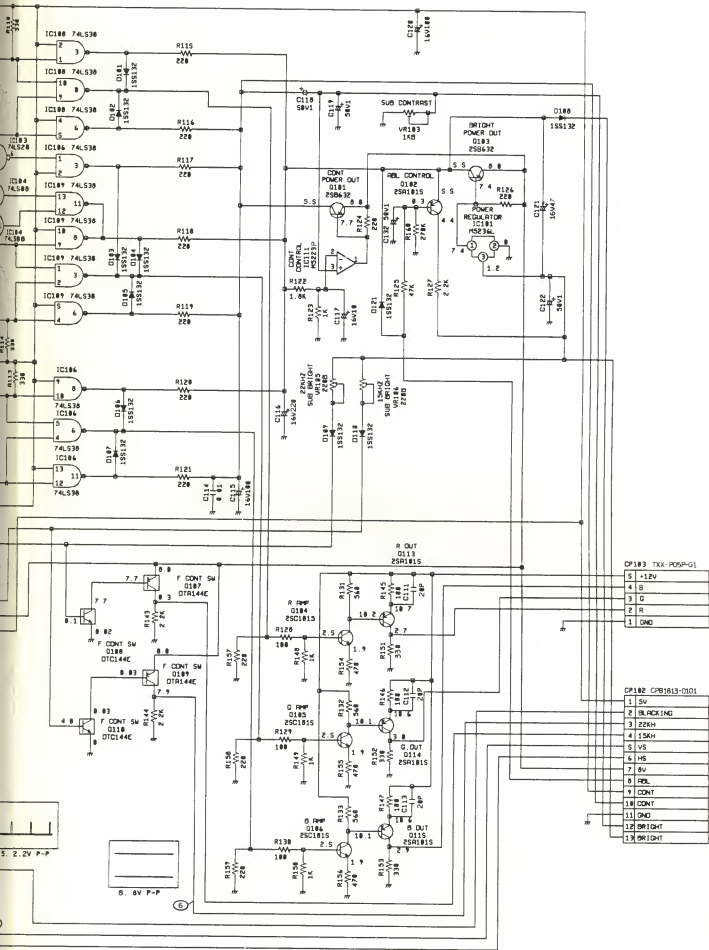

D103 7XX-POS-P-G1

5	-12V
4	B
3	C
2	R
1	OH

D102 CP81613-0101

1	5V
2	PACKING
3	22KH
4	15KH
5	5V
6	HS
7	8V
8	REL
9	CONT
10	CONT
11	OH
12	BRIGHT
13	BRIGHT



PC/ECD CHASSIS SCHEMATIC  
POWERSUPPLY

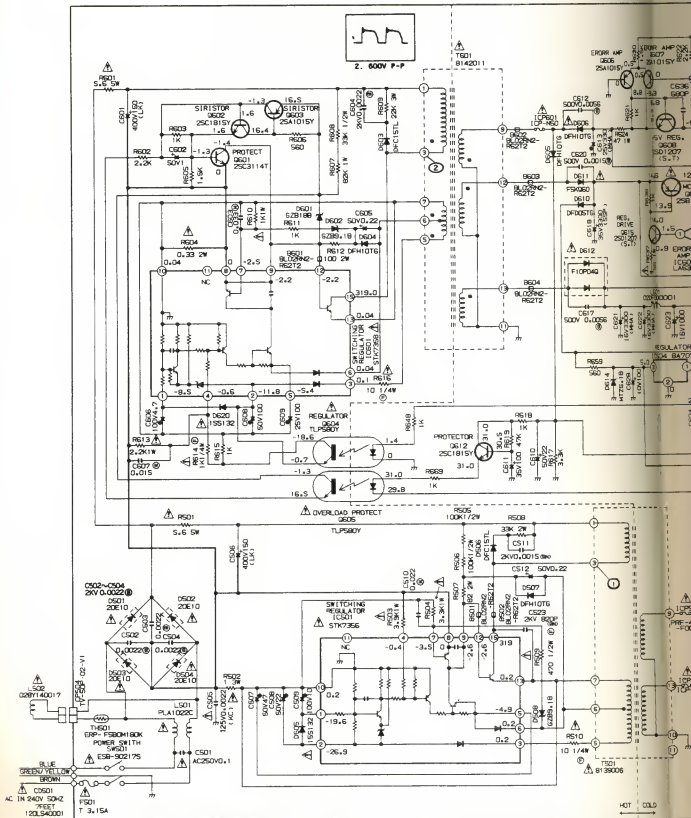

ATTENTION: LES PIÈCES MARQUÉES PAR UN Δ ETANT DANGEREUSES À UN POINT DE VUE SECURITE, N'UTILISER QUE CELLES INDIQUÉES DANS LA NOMENCLATURE DES PIÈCES.

CAUTION: SINCE THESE PARTS MARKED BY Δ ARE CRITICAL FOR SAFETY, USE ONES DESCRIBED IN PARTS LIST ONLY.

**SCHEMATIC DIAGRAM  
POWER SUPPLY**

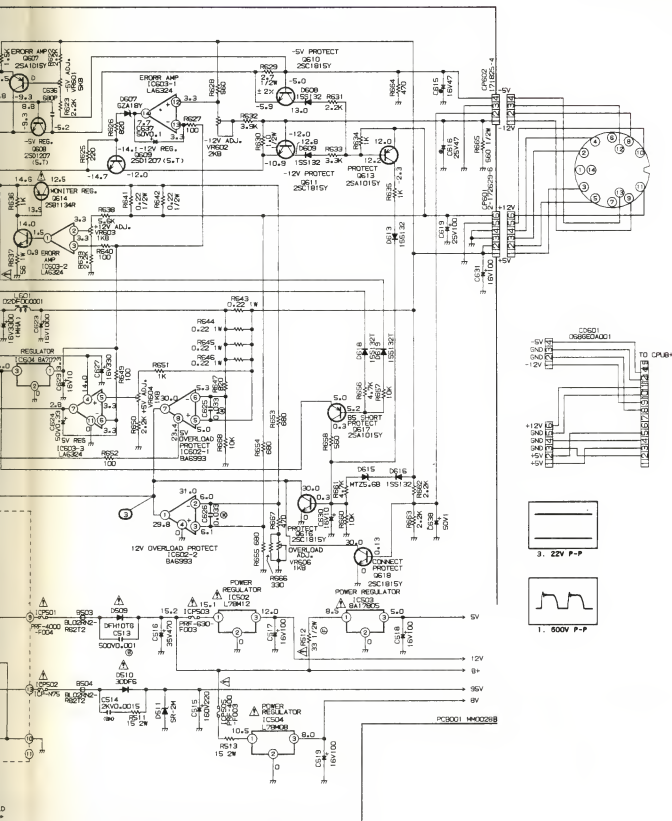

NOTE THIS SCHEMATIC DIAGRAM IS THE LATEST AT THE TIME OF PRINTING AND SUBJECT TO CHANGE WITHOUT NOTICE.

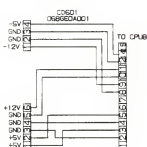

3. 22V P-P



1. 500V P-P

# SCHEMATIC DIAGRAM MONITOR

