

AMSTRAD



PC2386-65
PERSONAL COMPUTER
SERVICE MANUAL

CONTENTS

	Page
Technical Specification	2
Notes to Engineers	2
Safety Tests	2
Alignment Instructions	3
Memory/FDD Expansion PCBs	3
Main PCB Top View	4
Main PCB Bottom View	5
Expansion Board/LED PCB Top View	6
Expansion Board/LED PCB Bottom View	7
Power/Keyboard/Bug PCBs	8
Interconnection Diagrams	9, 10
Chassis Schematic Diagrams	11 - 15
Interconnection Diagrams	16, 17
Chassis Schematic Diagrams	18 - 29
Interconnection Diagrams	30, 31
Chassis Schematic Diagrams	32 - 41
Keyboard Chassis Schematic Diagram	42, 43
Electrical Parts List	44, 45
Keyboard Exploded View	46
Cabinet Exploded View & Parts List	47
Power Supply Chassis Schematic Diagram	48

TECHNICAL SPECIFICATION

Processor	: 80386
Clock Speed	: 20MHz
Wait States	: 0.05
Full Width Main Memory	: 32 bit
Maths Co-Processor Socket	: 80387
RAM (parity checked)	: 4MB
RAM Cache	: 64K / 35ns
Expansion Slots	: 5 x 16 bits
Asynchronous Bus Operation	: •
Hard Disk Option with 1:1 Interleave	: 65MB
Floppy Drives	: 1.4MB
External 5¼", 3½" Disk Drive &	: •
Tape Streamer Connector	
Hercules, CGA, EGA & VGA	: •
Compatible	
Bi-Directional Parallel Printer Port	: •
Serial RS232 Port	: •
Battery Backed Clock & Configuration RAM	: •
Mouse - with Microsoft Compatible	: •
.COM & .DRV	
101/102 'AT' type Keyboard	: •
Security Lock for Keyboard	: •
Volume Control for Speaker	: •
Built-In LIM 4.0	: •
RAM Division Option to	: •
Conventional/Extended/LIM	
Novell Netware Compatible	: Server
Microsoft	
MS-DOS	: 4.0
Windows	: 386
GW BASIC	: •
Dimensions	
System Unit	
Width	: 415mm
Height	: 160mm
Depth	: 485mm
Keyboard	
Width	: 475mm
Height	: 35mm
Depth	: 200mm

NOTES TO ENGINEERS

Please be advised that no component level repairs are to be carried out on Main CPU PCB. After diagnosis test if the fault is confirmed replace CPU PCB.

This is obtainable from our authorised spares outlet.

The same applies to the floppy disc drives and hard disc drives.

Any attempts to repair or replace any parts or components within these units will invalidate any warranty or part warranty on the item.

Replacement items will be available from our authorised spares outlet.

PSU & Monitors are subject to component level repairs.

Any information which is not published herein may be made available upon special request to Amstrad Spares & Service Department.

SAFETY TEST

All monitors are tested to the following specifications.

- Flash Test:** Test at 1.5kV RMS / 3 sec between the live and neutral poles of the mains lead and all accessible metal points on the exterior of the set.
- Insulation Resistance Test:** Test at 1.5kV RMS / 3 sec between the live and neutral poles of the mains lead and all accessible metal points on the exterior of the set to show a resistance greater than 4Mohms.
- Earth Continuity Test:** The resistance of the mains lead shall not exceed 0.5ohms.

PLEASE NOTE: When any work is completed on this unit, correct safety tests must be carried out to ensure continued electrical safety.

PLEASE NOTE: All parts shown with the part number prefix  are Safety Items and must be replaced with similar items having an identical safety specification.

All those items may be purchased direct from AMSTRAD plc.

In keeping with our policy of continually improving our service and the technical quality of our products, we reserve the right to change component types, manufacturers, sources of supply or technical specification at any time.

AMSTRAD PLC
BRENTWOOD HOUSE, 169 KINGS ROAD, BRENTWOOD, ESSEX CM14 4EF.
Telephone: 0277 230222. Telex: 0277 211350 Amsele G.

PC2386 ALIGNMENT INSTRUCTIONS

STEP	FUNCTION	SIGNAL IN	SIGNAL OUT	METHOD	REMARKS
1.	+5V D.C. Adjustment.	—	—	Connect D.V.M. to Test Point A & Ground. Adjust VR604 to read 5.00V ±0.05V D.C.	Refer to Fig. A.
2.	+12V D.C. Adjustment.	—	—	Connect D.V.M. to Test Point B & Ground. Adjust VR603 to read 12.00V D.C. ±0.05V D.C.	Refer to Fig. A.
3.	VCO Cont. Voltage Adjustment.	—	—	Connect D.V.M. to Pin 6 of IC316. Adjust TC301 to read 3.5V D.C.	
4.	Primary Protect Adjustment.	—	—	Turn VR601 anti-counterclockwise till the protection starts to cut in. Turn back a little to make it inactive.	
5.	R.T.C. Adjustment.	—	—	Connect Odometer to Pin 21 of IC115. Set the odometer to 0.2 sec/day setting and read "0.00" using TC101.	

MAJOR COMPONENTS LOCATION GUIDE

MAIN PCB

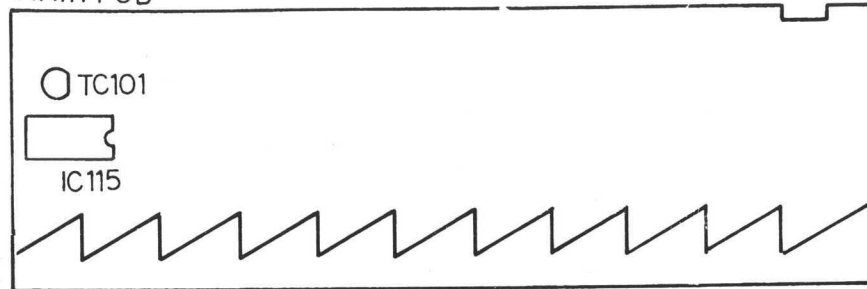

EX. PCB

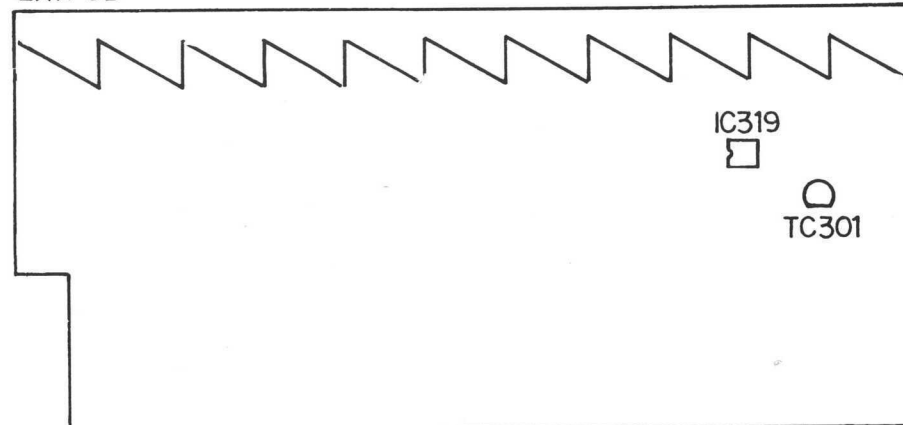

POWER PCB

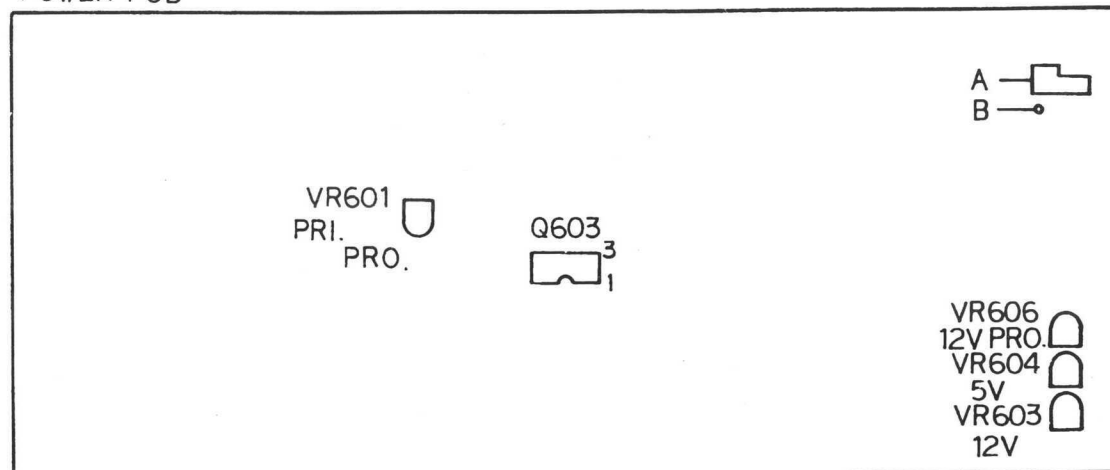
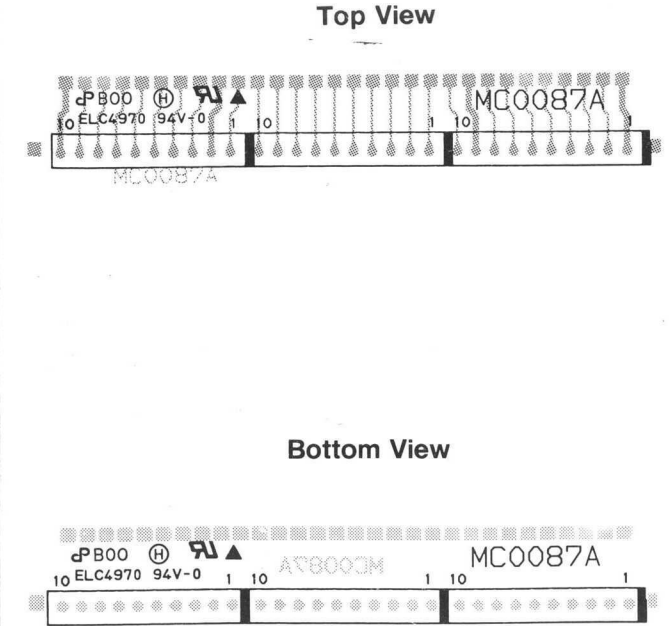
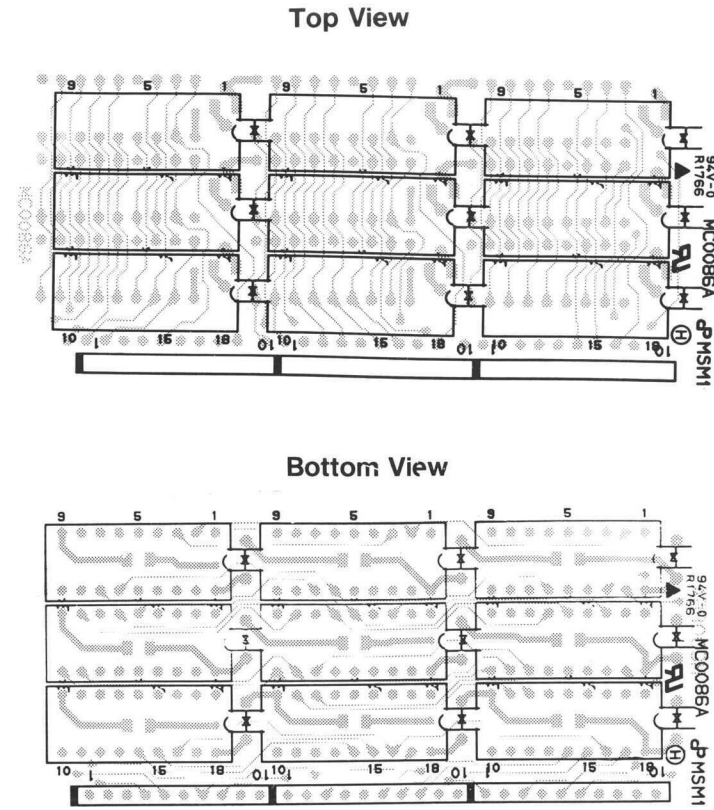
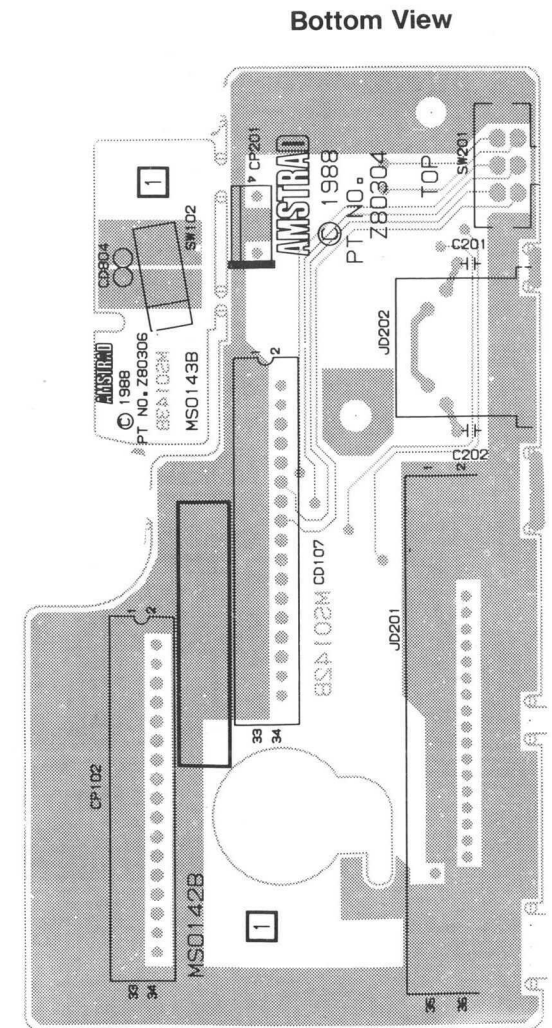
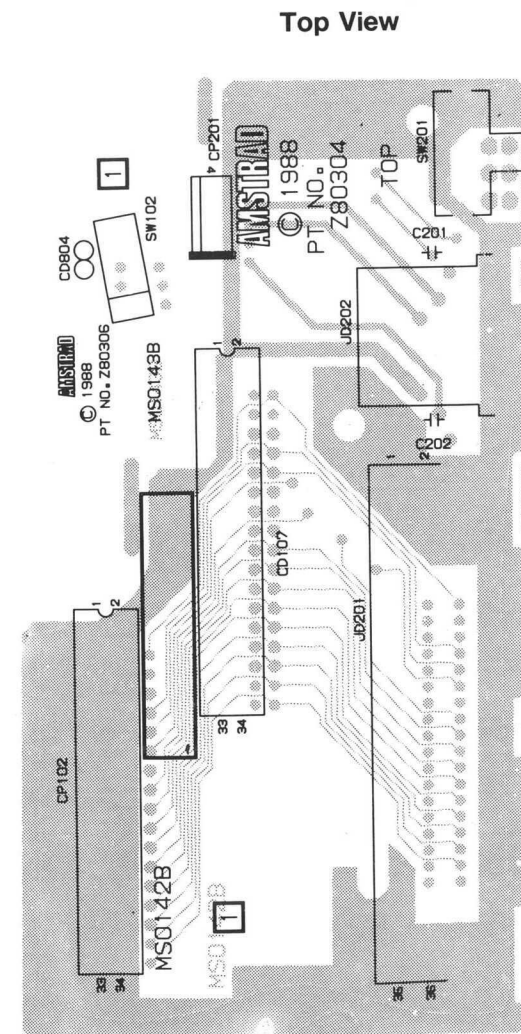

Fig. A

MEMORY P.C.B.



FDD EXPANSION SWITCH P.C.B.



MAIN P.C.B. (Top View)

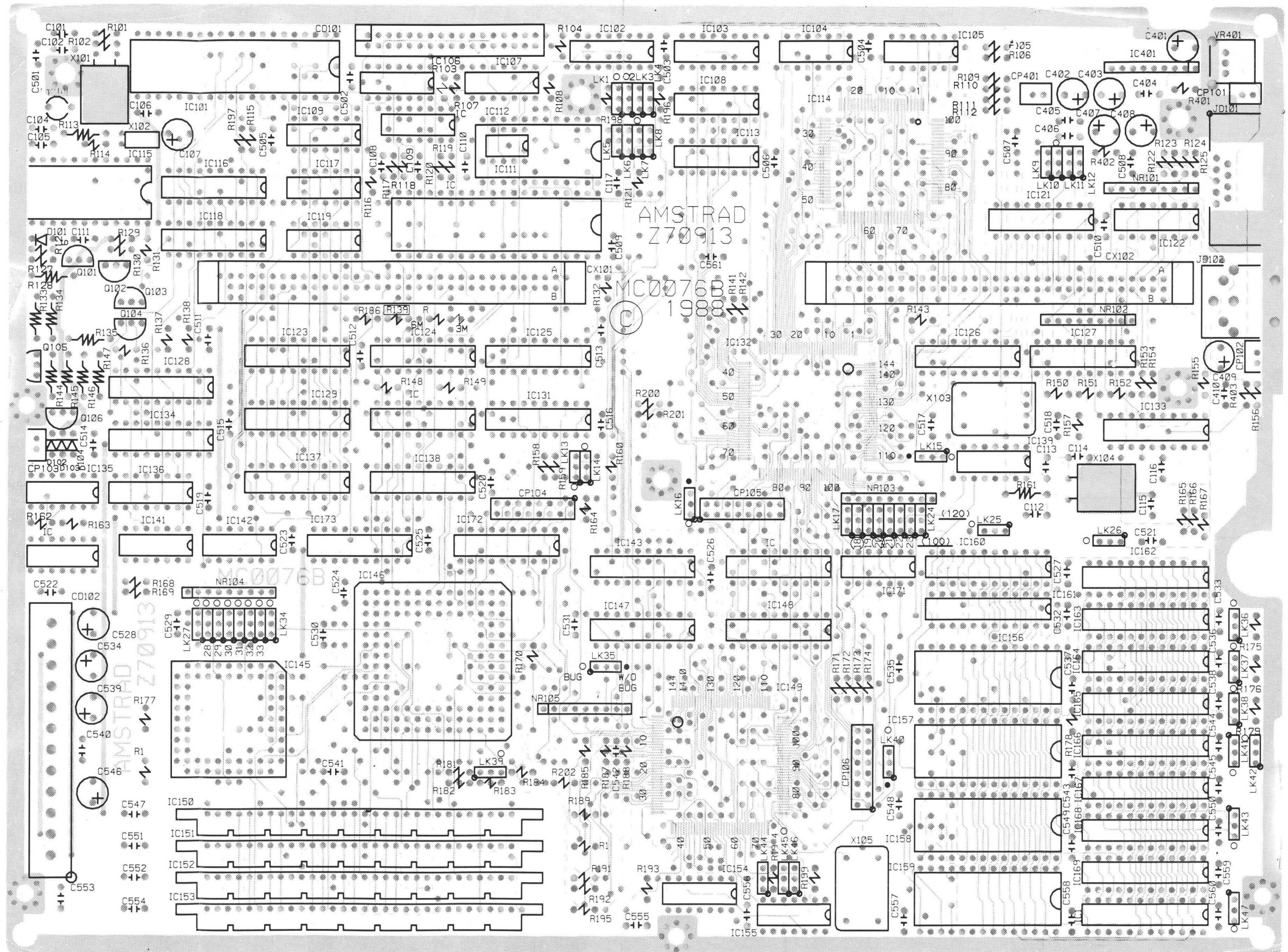

MAIN P.C.B. (Bottom View)

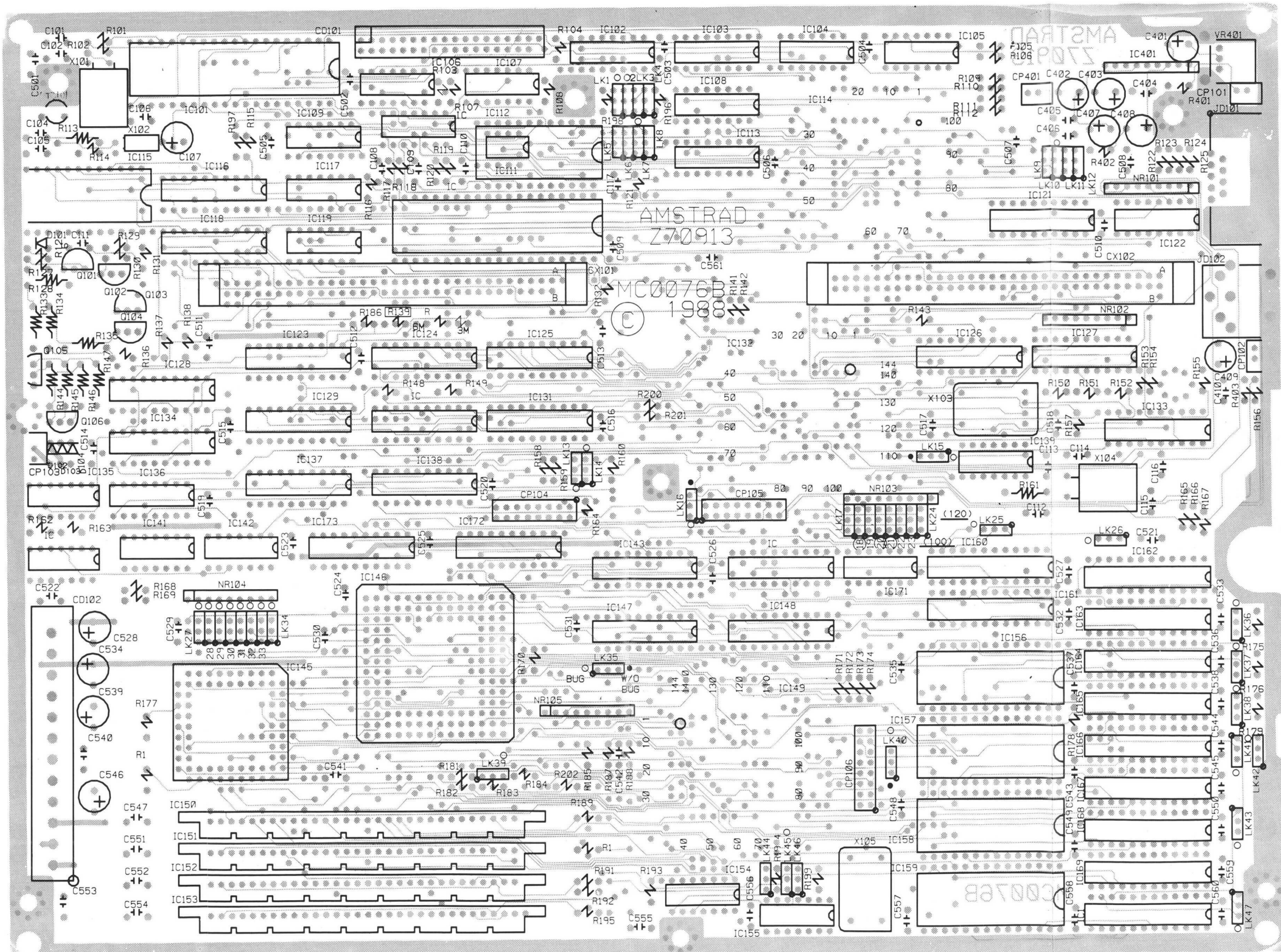

EXPANSION BOARD / LED P.C.B. (Top View)

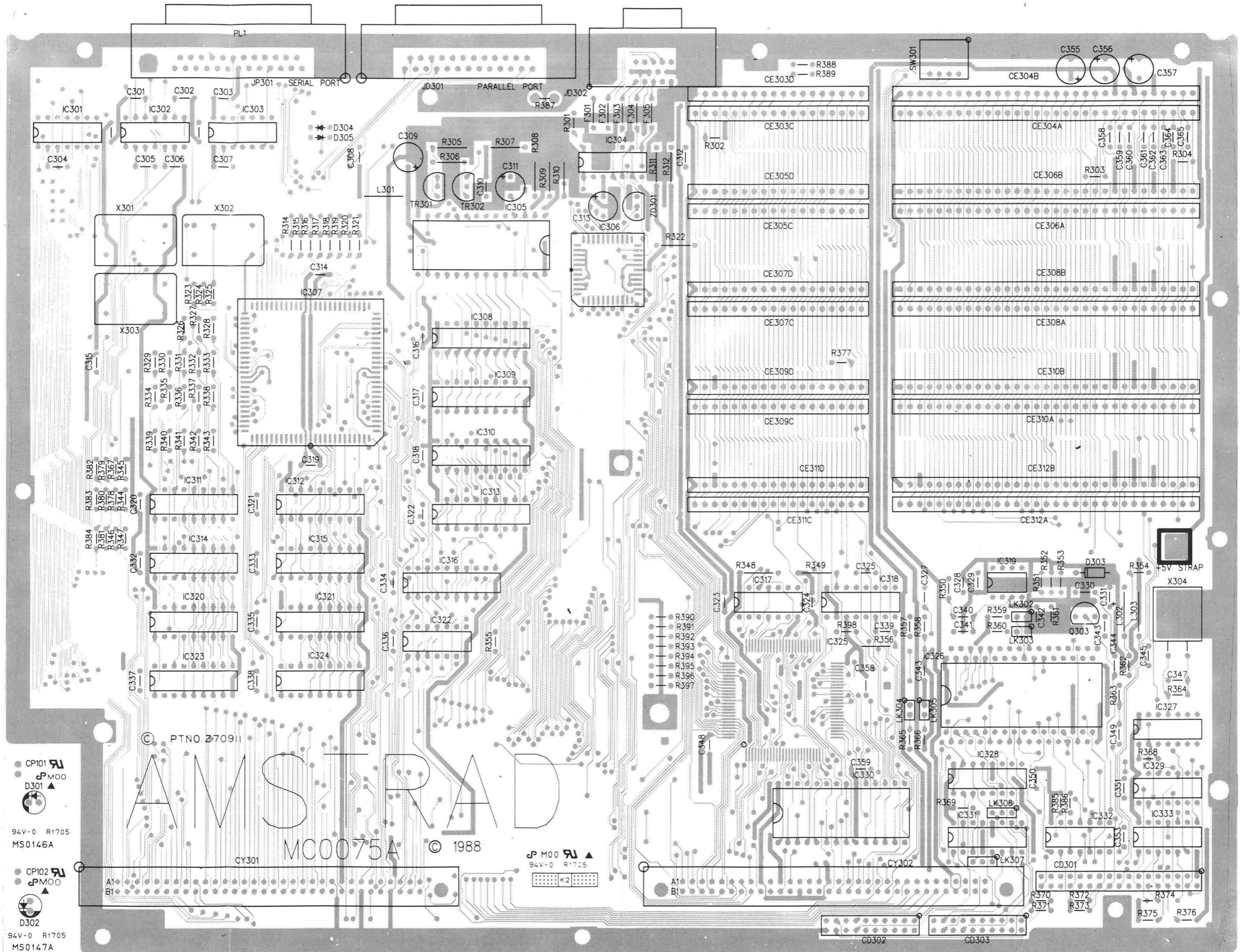

PTNO. 270911
AMSTRAD
 MC0075A © 1988

CP101 M00
 D301
 94V-0 R1705
 MS0146A

CP102 M00
 D302
 94V-0 R1705
 MS0147A

M00
 94V-0 R1705

EXPANSION BOARD / LED P.C.B. (Bottom View)

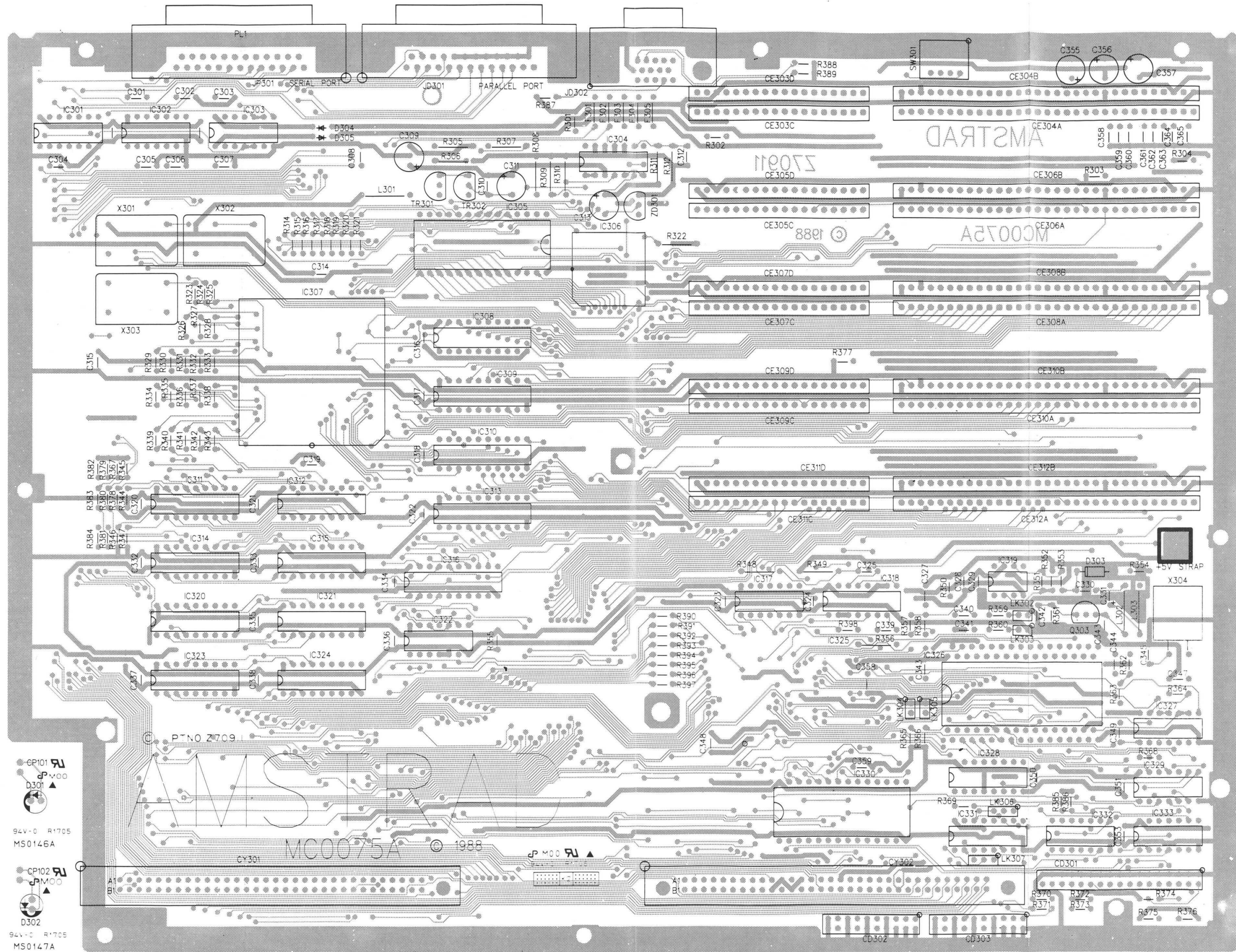

POWER P.C.B.

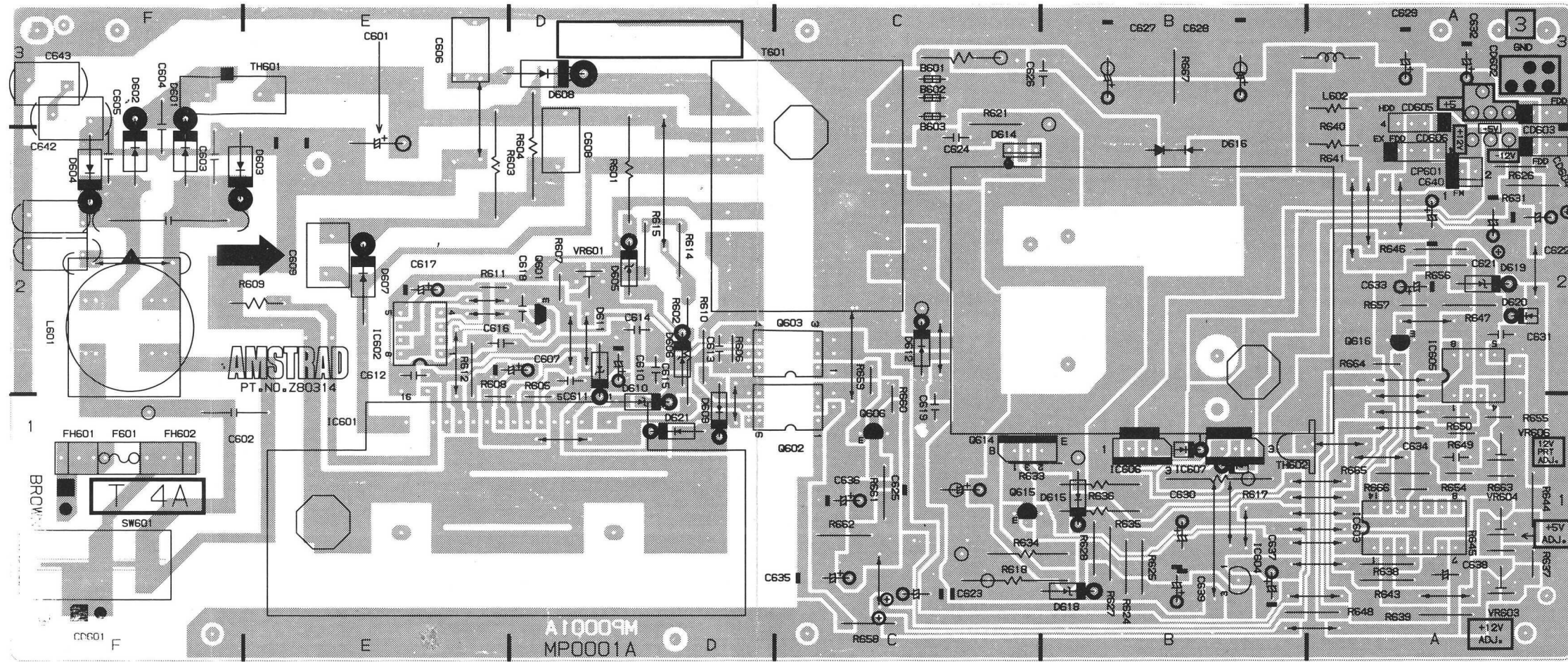

KEYBOARD P.C.B.

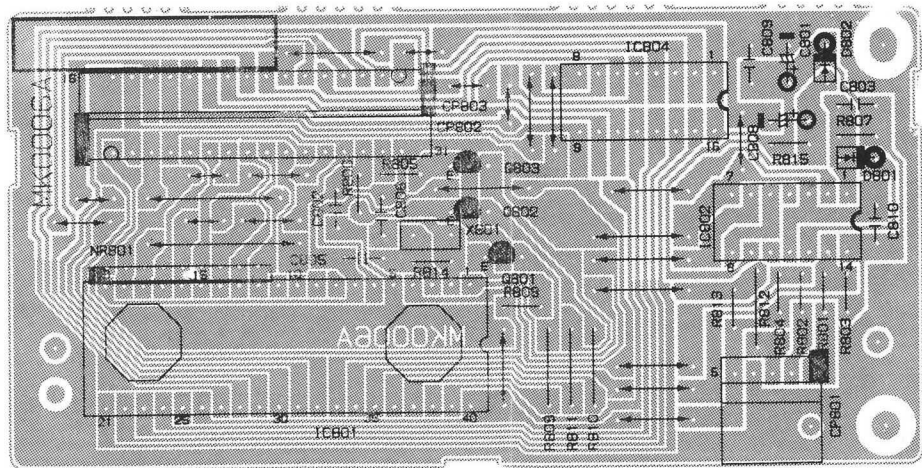

Top View

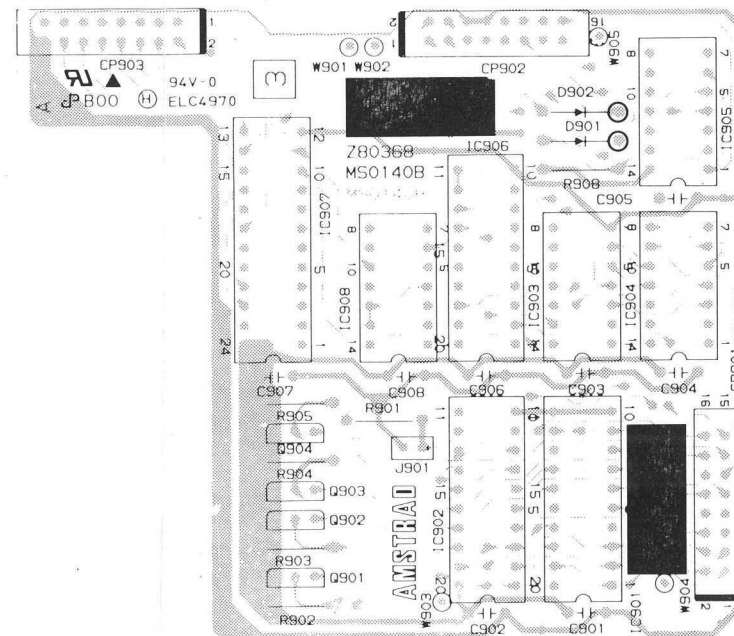

BUG P.C.B.

Bottom View

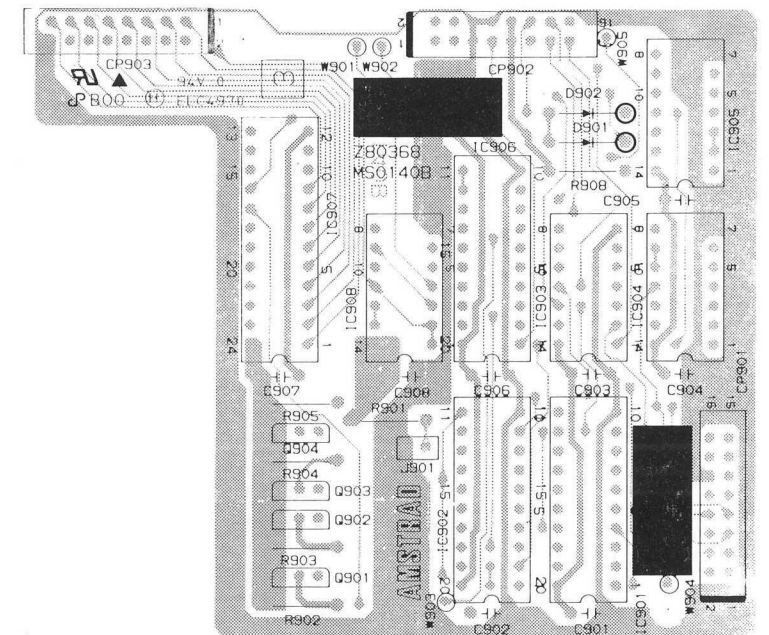

NOTE: Bug P.C.B. will change between first 30,000 units and next 30,000 units.

INTERCONNECTION DIAGRAM

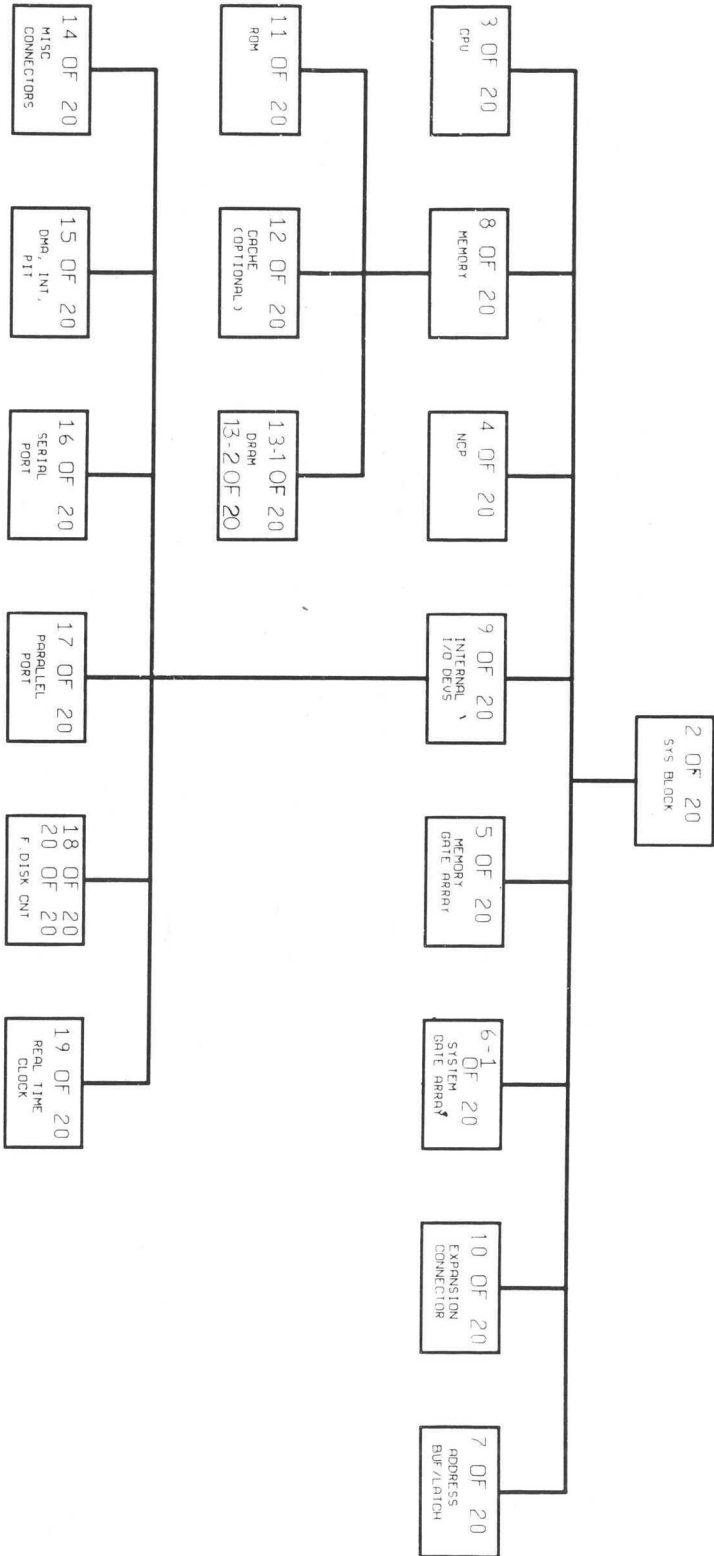

INTERCONNECTION DIAGRAM

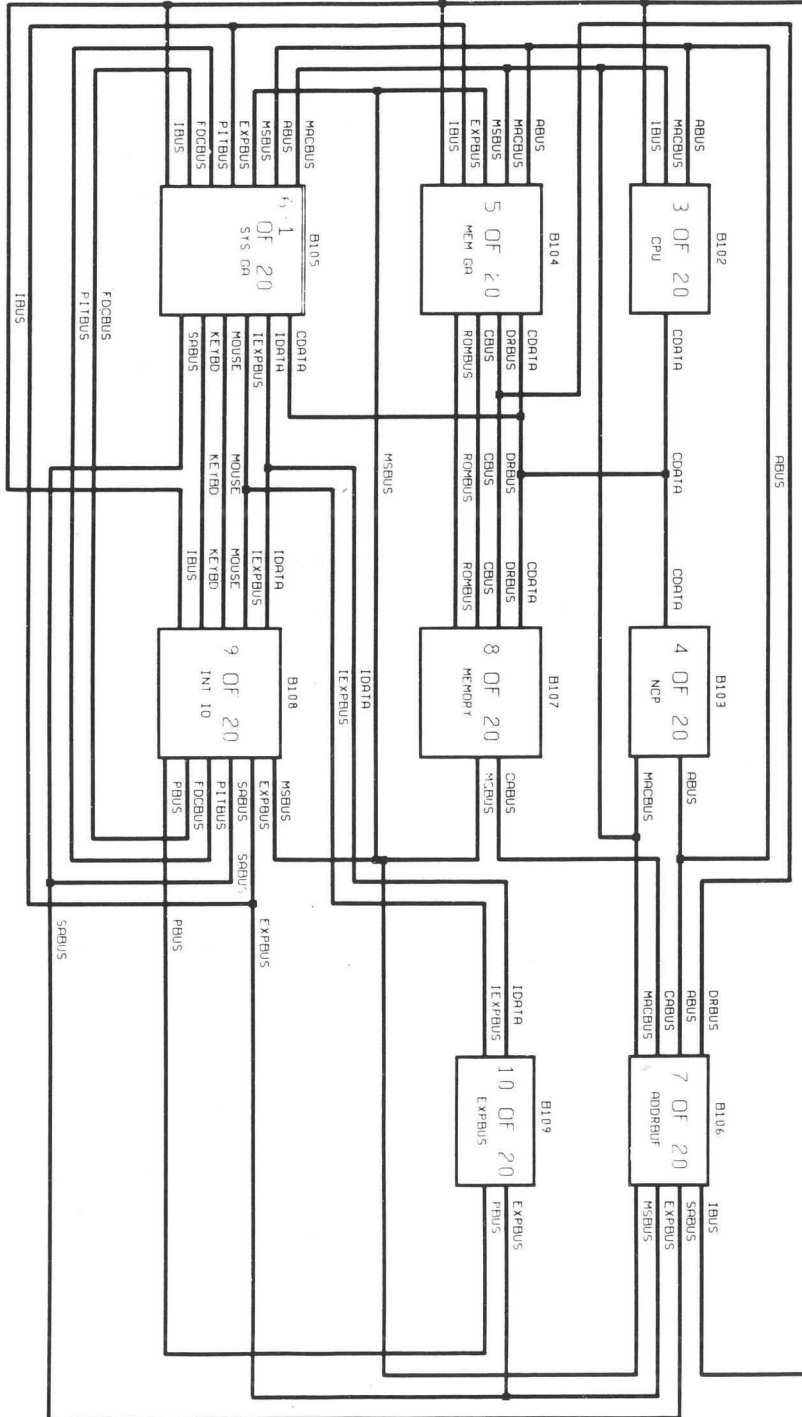

CHASSIS SCHEMATIC DIAGRAM

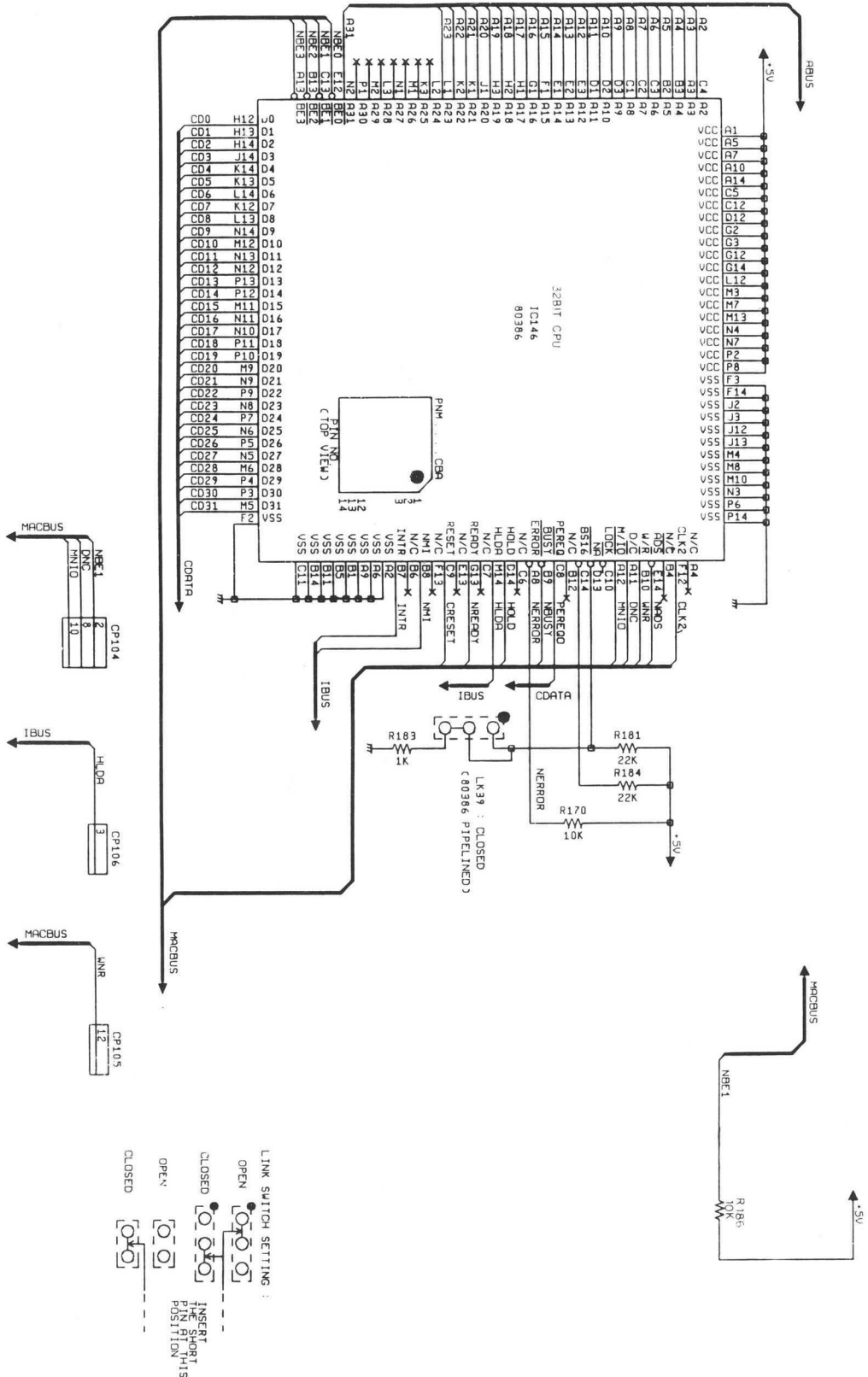

CHASSIS SCHEMATIC DIAGRAM

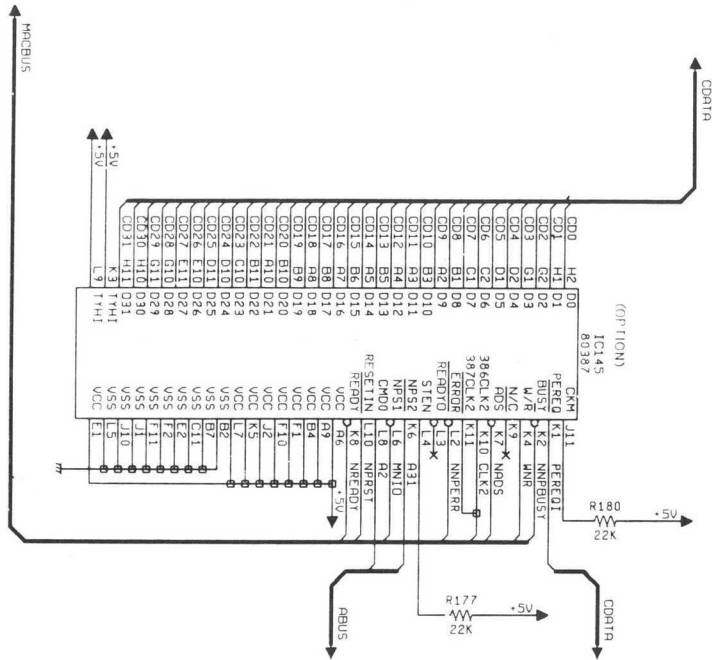

NOTE: THIS SCHEMATIC DIAGRAM IS THE LATEST AT THE TIME OF PRINTING AND SUBJECT TO CHANGE WITHOUT NOTICE.

4 01 20

CHASSIS SCHEMATIC DIAGRAM

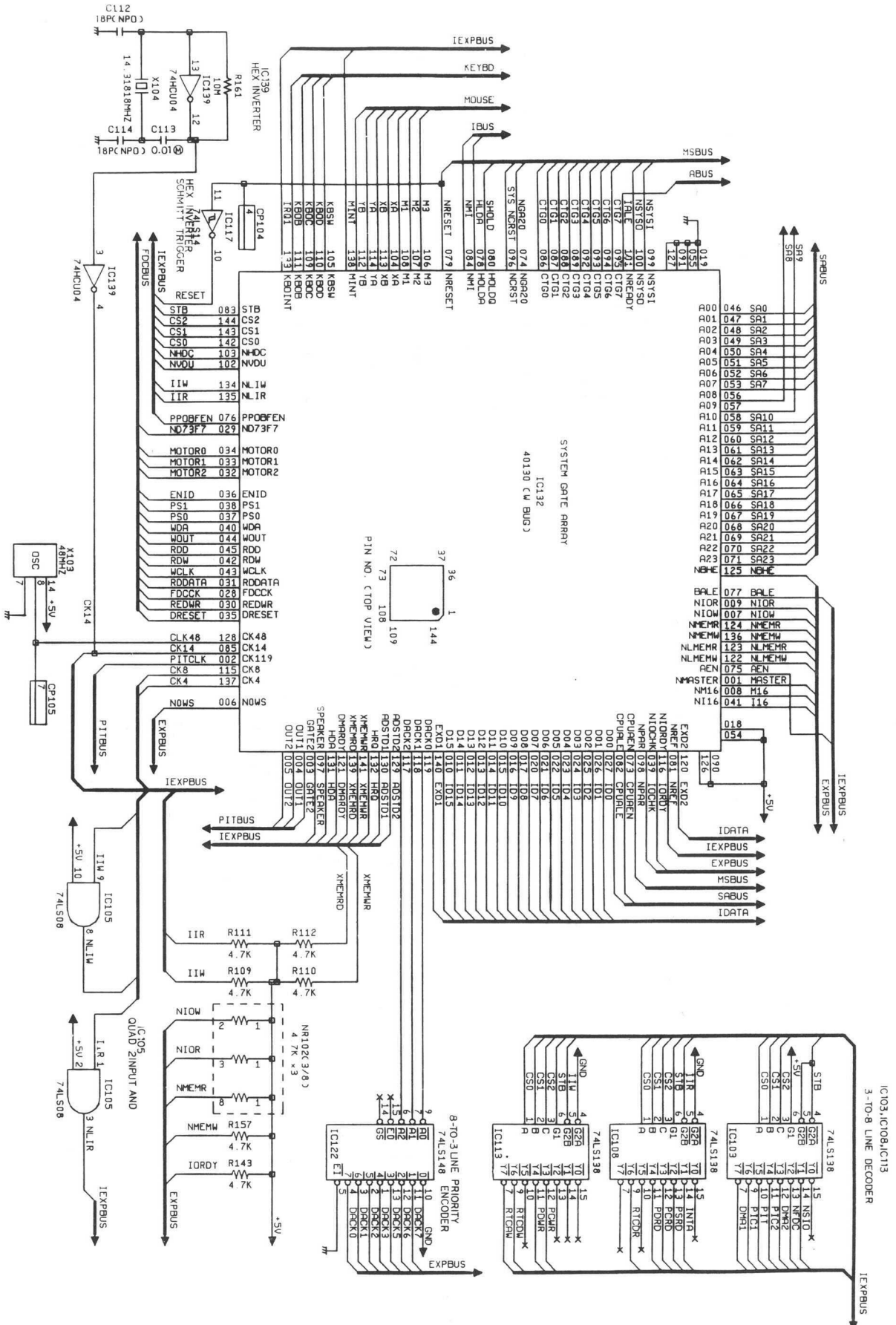

NOTE: THIS SCHEMATIC DIAGRAM IS THE LATEST AT THE TIME OF PRINTING AND SUBJECT TO CHANGE WITHOUT NOTICE.

CHASSIS SCHEMATIC DIAGRAM

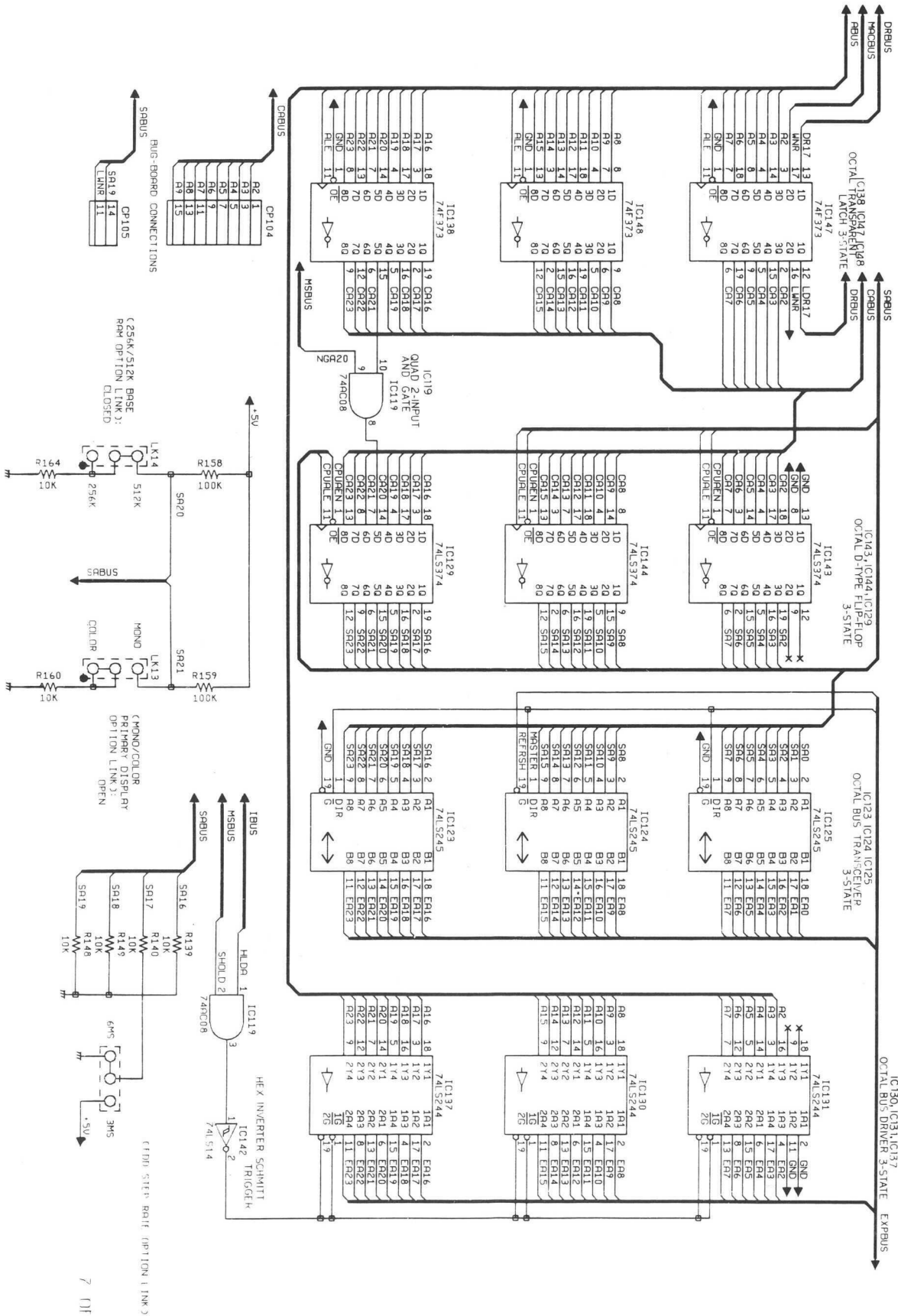

NOTE: THIS SCHEMATIC DIAGRAM IS THE LATEST AT THE TIME OF PRINTING AND SUBJECT TO CHANGE WITHOUT NOTICE.

INTERCONNECTION DIAGRAM

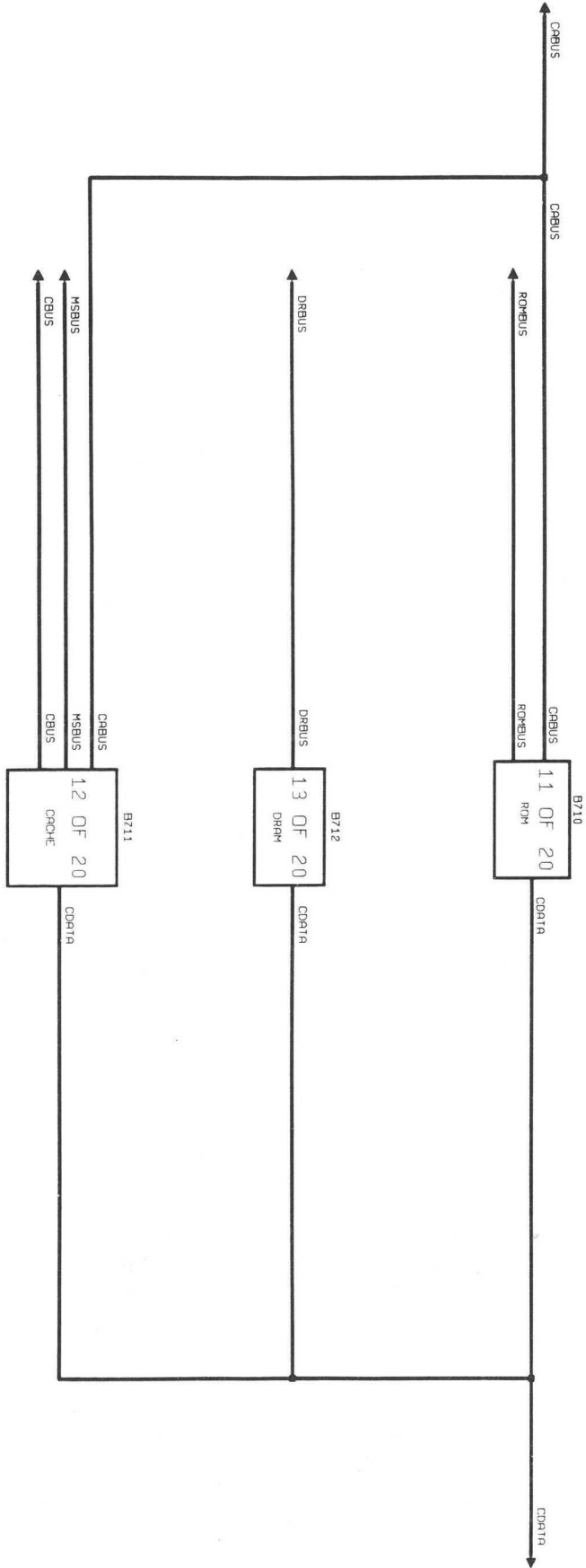

INTERCONNECTION DIAGRAM

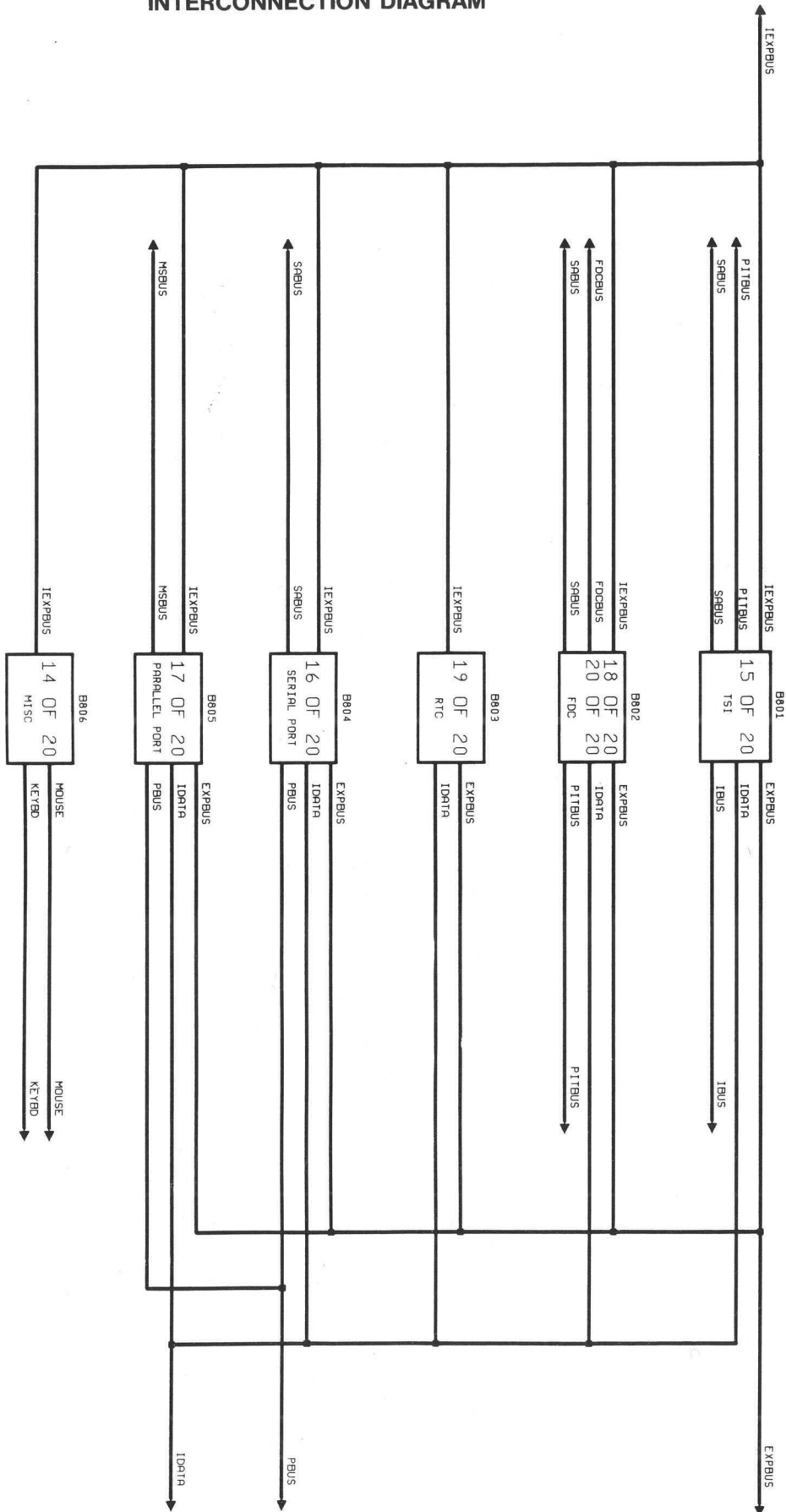

CHASSIS SCHEMATIC DIAGRAM

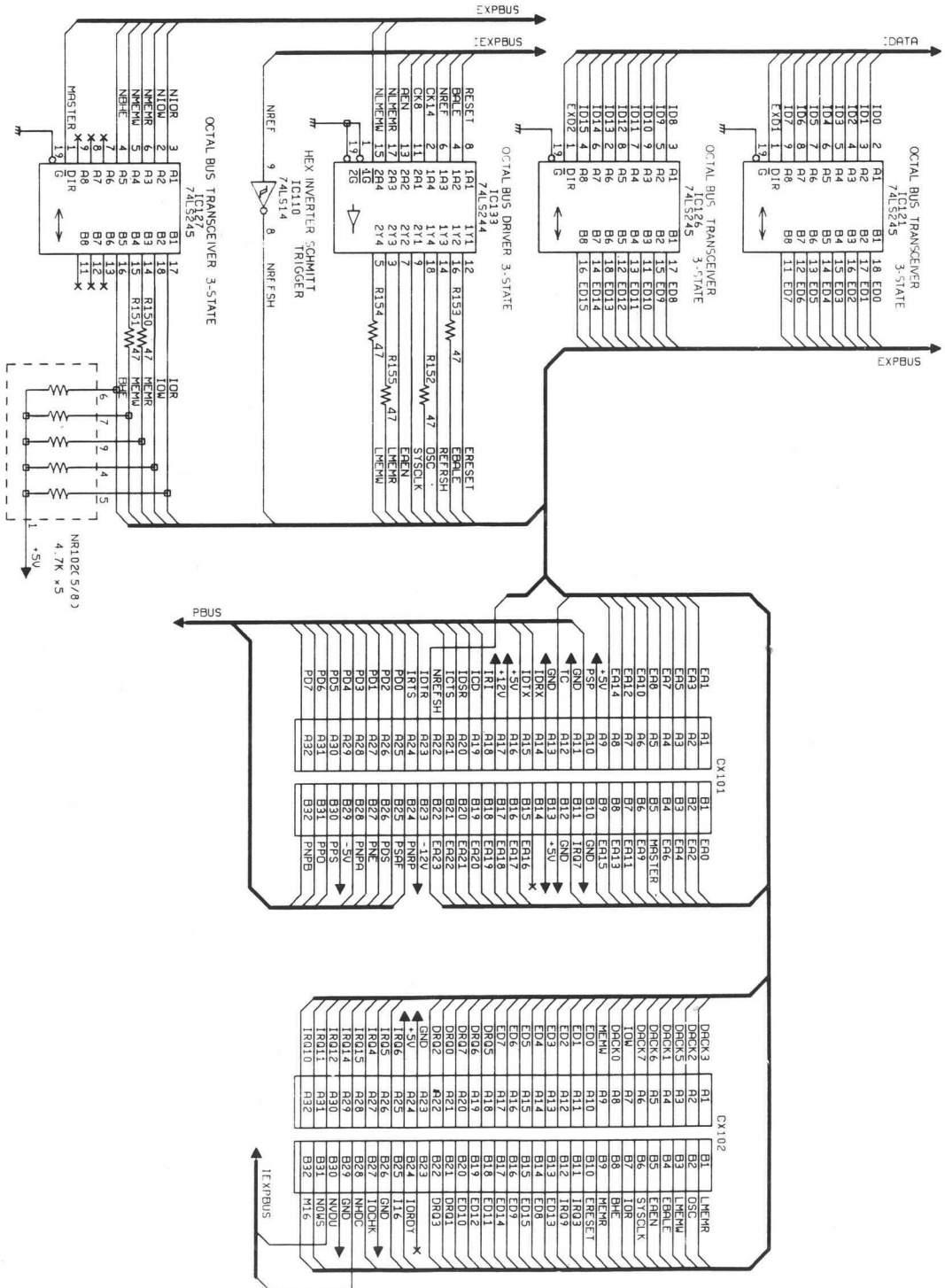

NOTE: THIS SCHEMATIC DIAGRAM IS THE LATEST AT THE TIME OF PRINTING AND SUBJECT TO CHANGE WITHOUT NOTICE.

2-3226

CHASSIS SCHEMATIC DIAGRAM

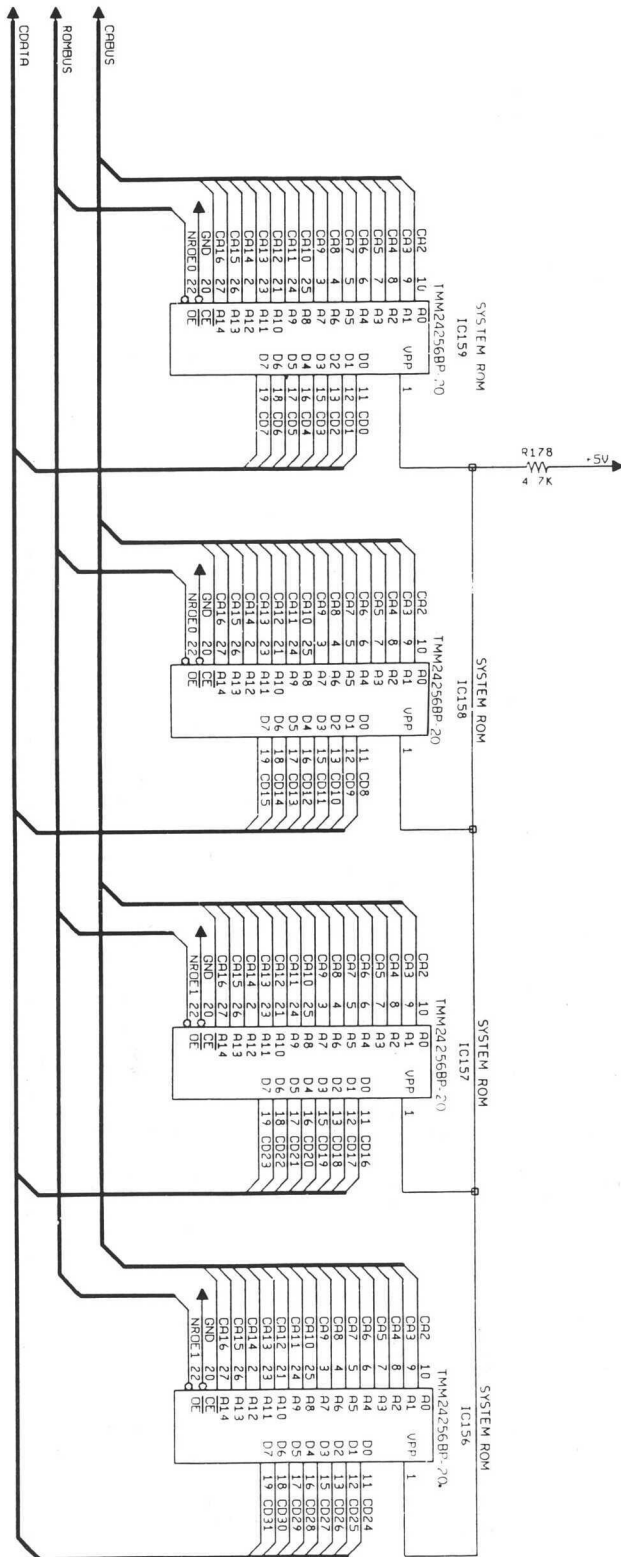

NOTE: THIS SCHEMATIC DIAGRAM IS THE LATEST AT THE TIME OF PRINTING AND SUBJECT TO CHANGE WITHOUT NOTICE.

CHASSIS SCHEMATIC DIAGRAM

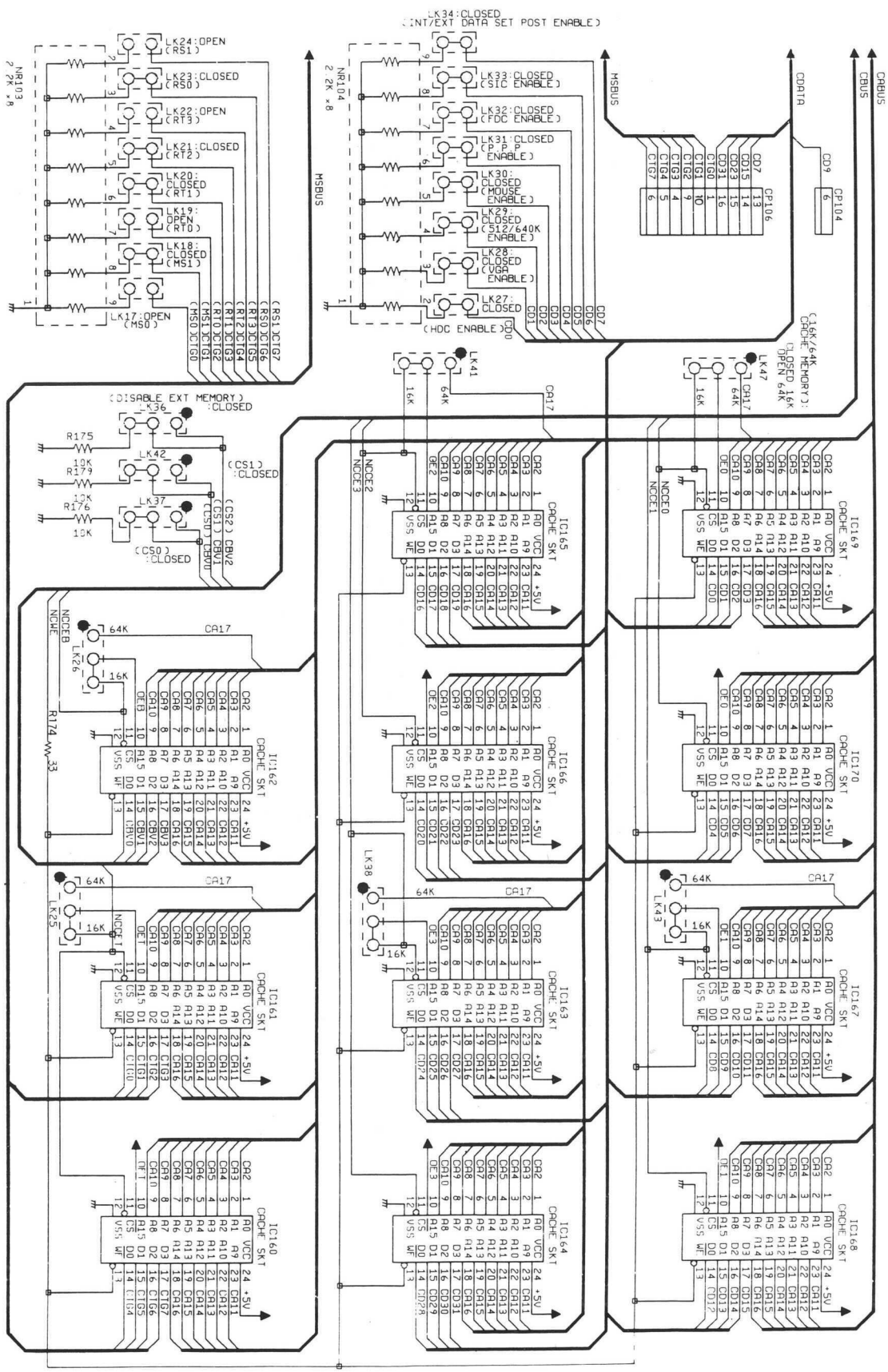

NOTE: THIS SCHEMATIC DIAGRAM IS THE LATEST AT THE TIME OF PRINTING AND SUBJECT TO CHANGE WITHOUT NOTICE.

CHASSIS SCHEMATIC DIAGRAM

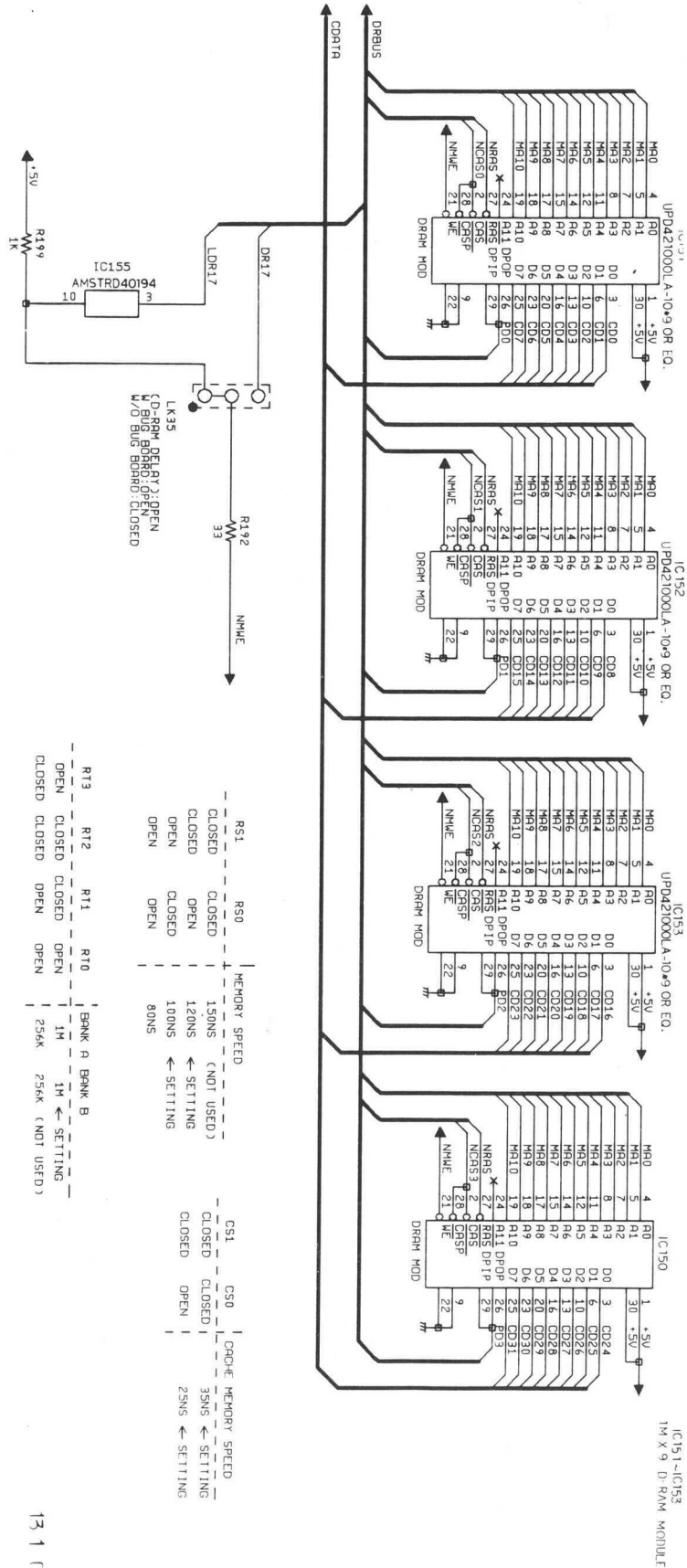

NOTE: THIS SCHEMATIC DIAGRAM IS THE LATEST AT THE TIME OF PRINTING AND SUBJECT TO CHANGE WITHOUT NOTICE.

13 1 01 20

CHASSIS SCHEMATIC DIAGRAM

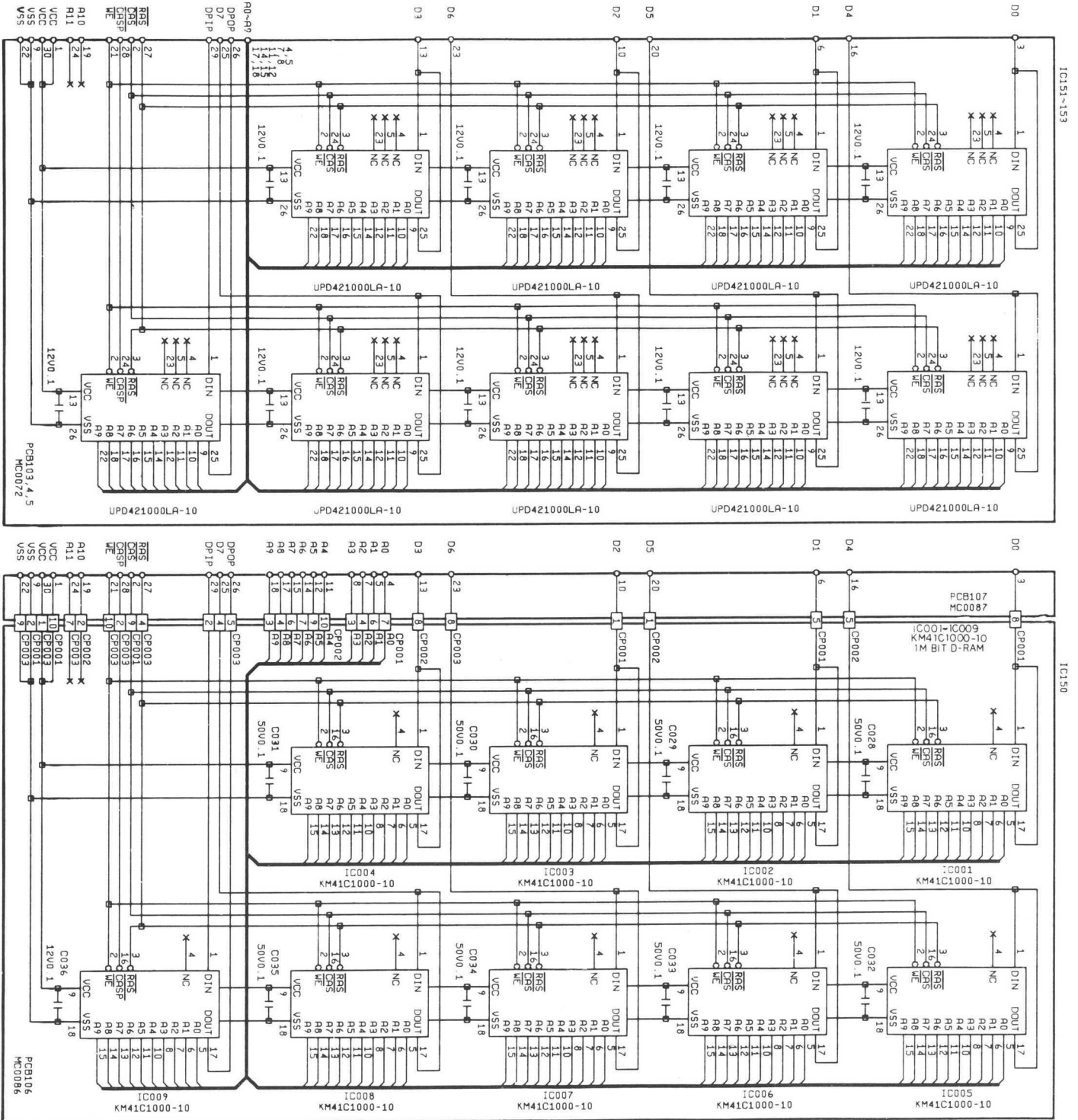

NOTE: THIS SCHEMATIC DIAGRAM IS THE LATEST AT THE TIME OF PRINTING AND SUBJECT TO CHANGE WITHOUT NOTICE.

13-2 OF 20

CHASSIS SCHEMATIC DIAGRAM

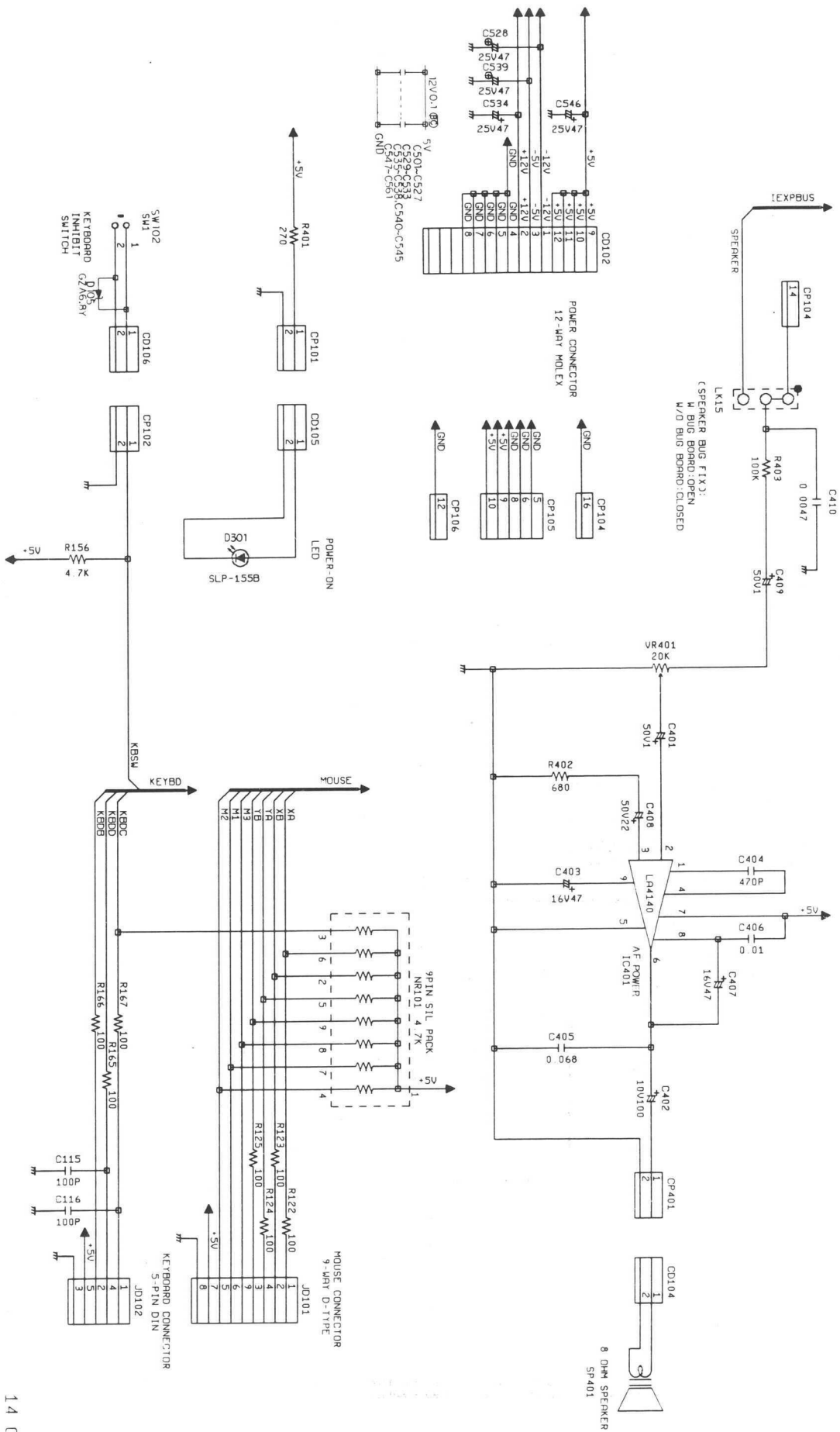

NOTE: THIS SCHEMATIC DIAGRAM IS THE LATEST AT THE TIME OF PRINTING AND SUBJECT TO CHANGE WITHOUT NOTICE.

CHASSIS SCHEMATIC DIAGRAM

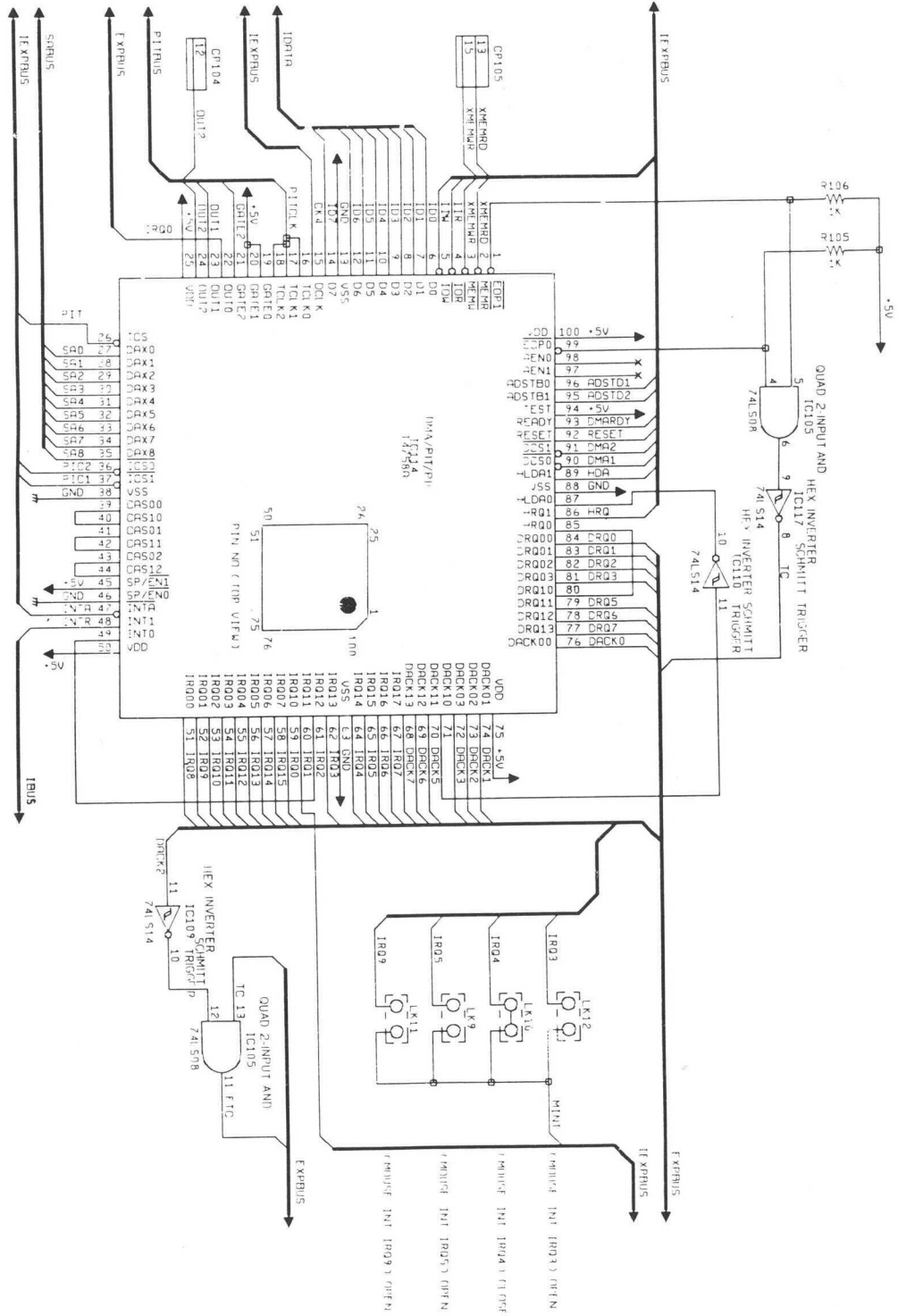

NOTE: THIS SCHEMATIC DIAGRAM IS THE LATEST AT THE TIME OF PRINTING AND SUBJECT TO CHANGE WITHOUT NOTICE

2-3231

CHASSIS SCHEMATIC DIAGRAM

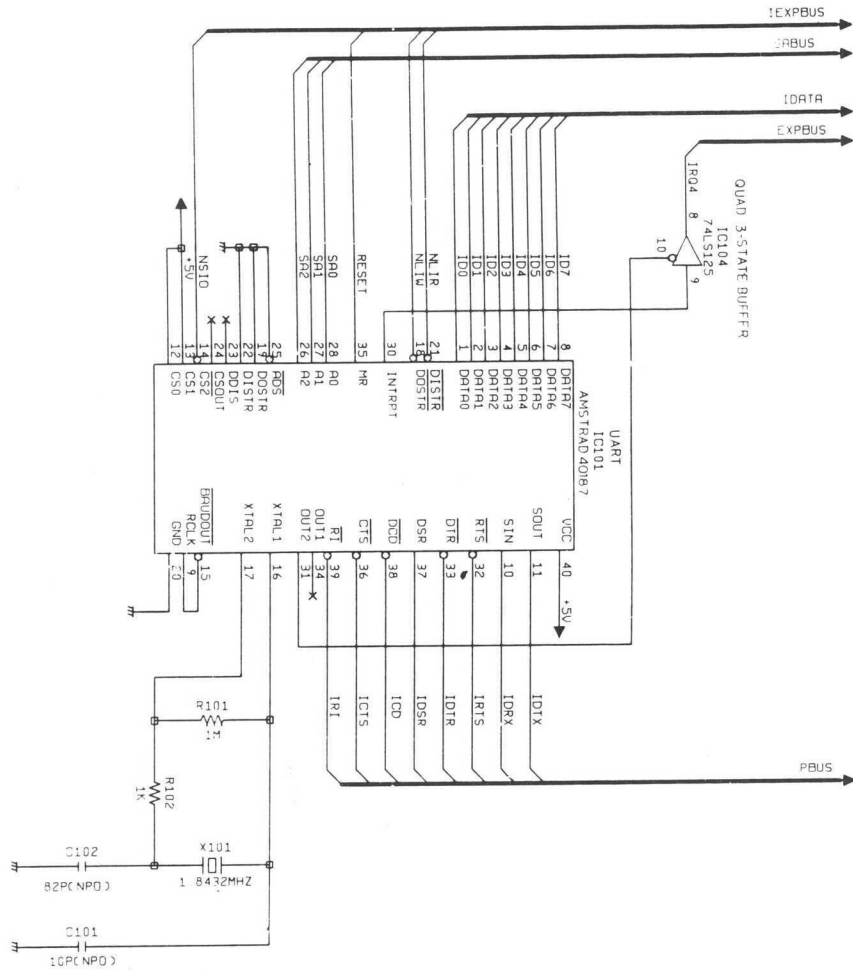

NOTE: THIS SCHEMATIC DIAGRAM IS THE LATEST AT THE TIME OF PRINTING AND SUBJECT TO CHANGE WITHOUT NOTICE.

2-3232

CHASSIS SCHEMATIC DIAGRAM

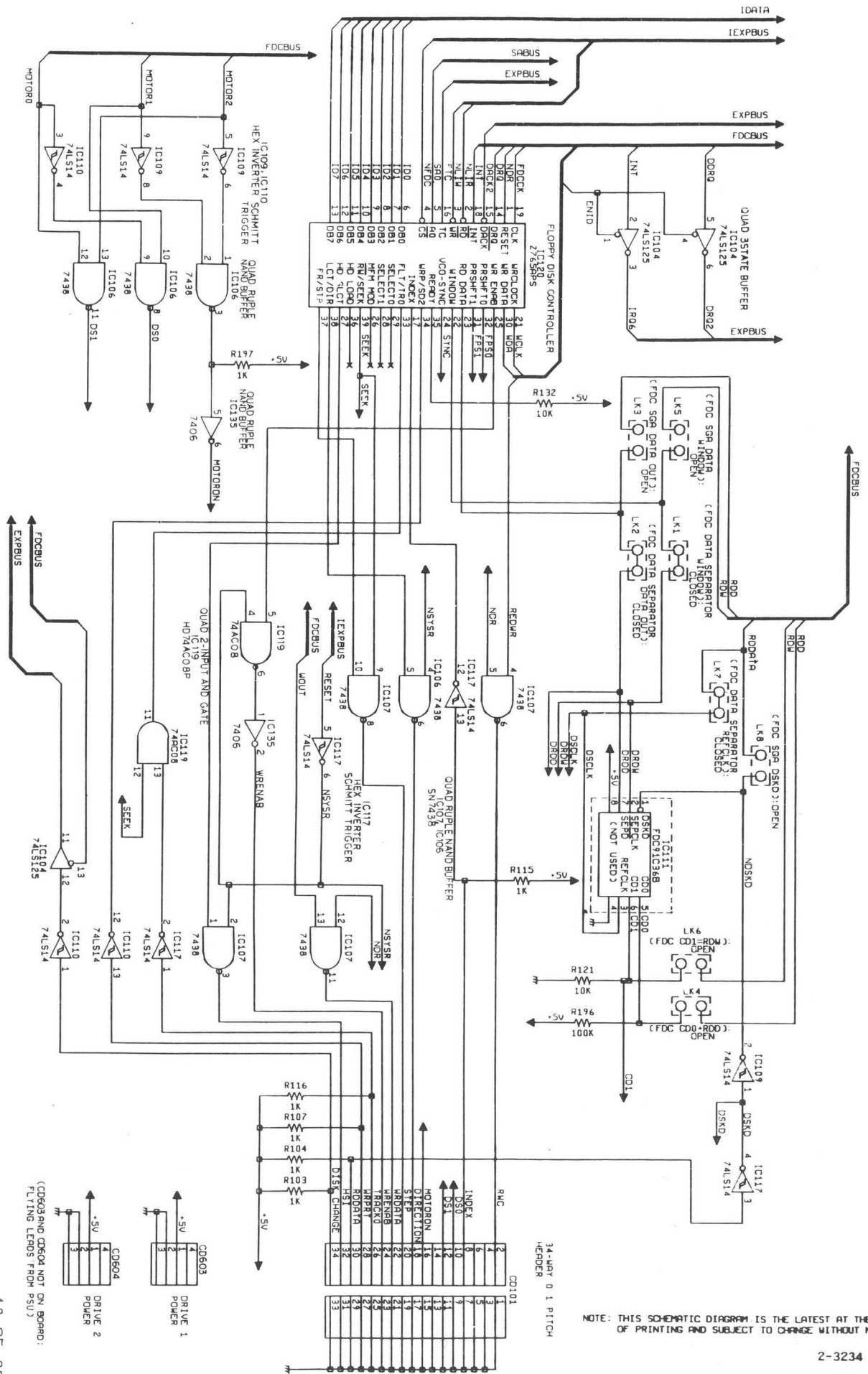

NOTE: THIS SCHEMATIC DIAGRAM IS THE LATEST AT THE TIME OF PRINTING AND SUBJECT TO CHANGE WITHOUT NOTICE.

CHASSIS SCHEMATIC DIAGRAM

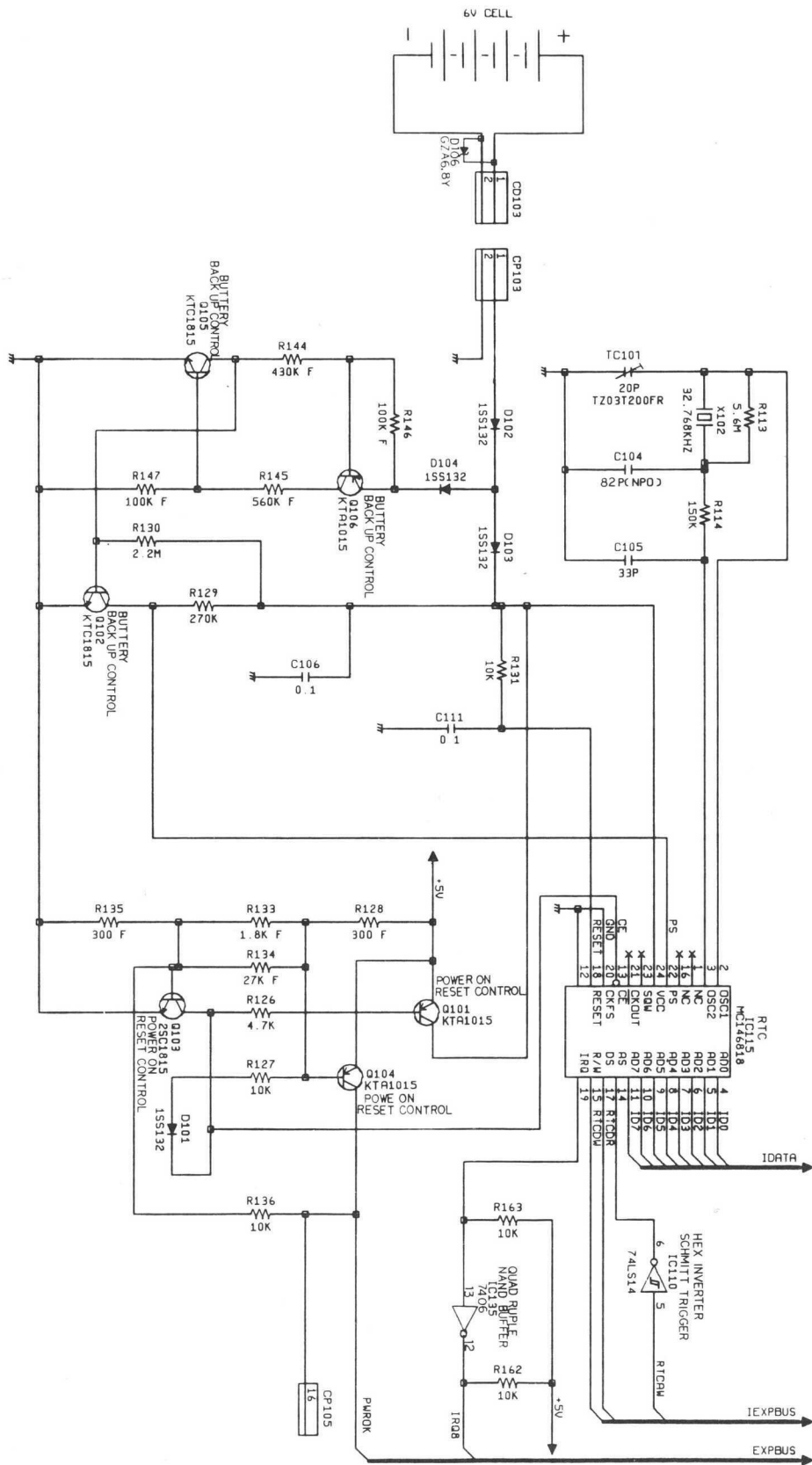

19 OF 20

NOTE: F, G, H, I, AND J MARKED AROUND THE PARTS IN THE SCHEMATIC DIAGRAM INDICATES THE FOLLOWING ERROR RATE.
 F: ±1%, G: ±2%, H: ±3%, I: ±4%, J: ±5%

NOTE: THIS SCHEMATIC DIAGRAM IS THE LATEST AT THE TIME OF PRINTING AND SUBJECT TO CHANGE WITHOUT NOTICE.

CHASSIS SCHEMATIC DIAGRAM

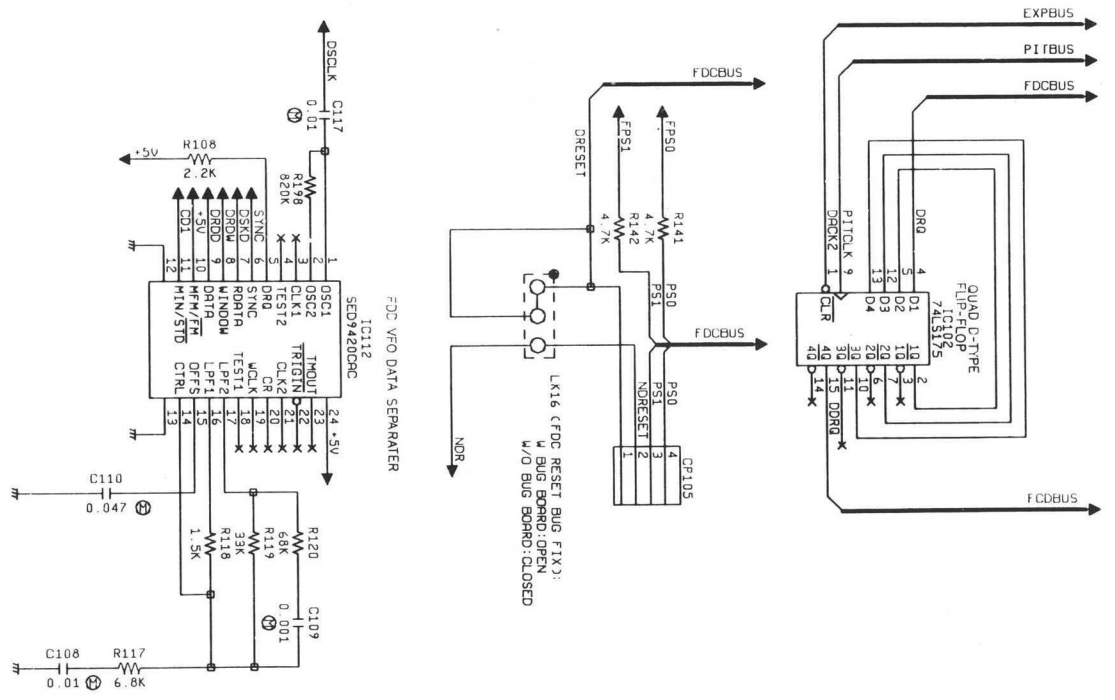
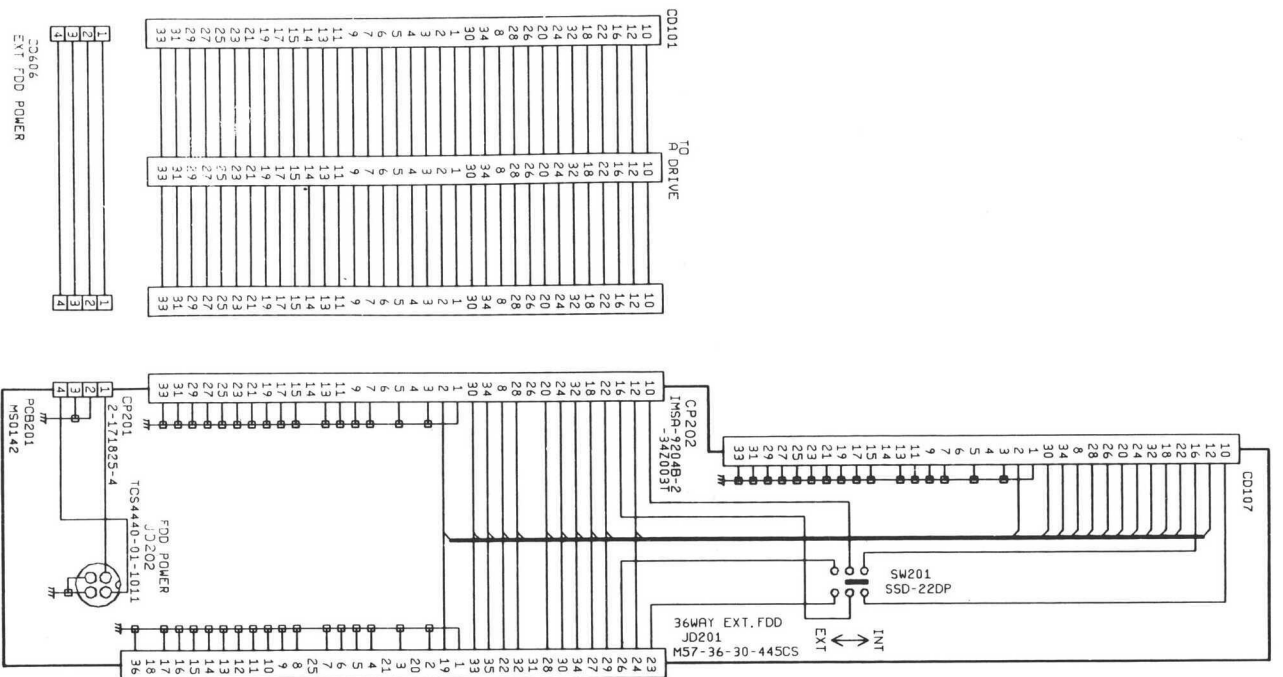

NOTE: THIS SCHEMATIC DIAGRAM IS THE LATEST AT THE TIME OF PRINTING AND SUBJECT TO CHANGE WITHOUT NOTICE.

INTERCONNECTION DIAGRAM

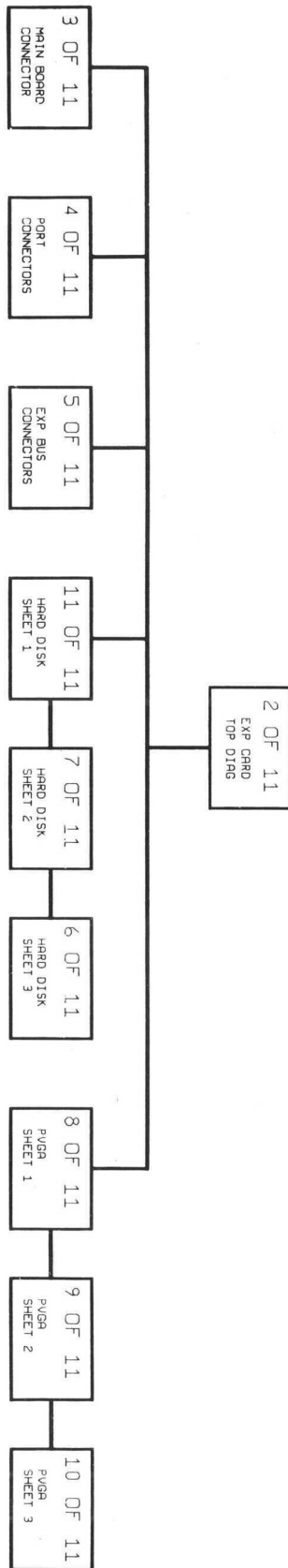

INTERCONNECTION DIAGRAM

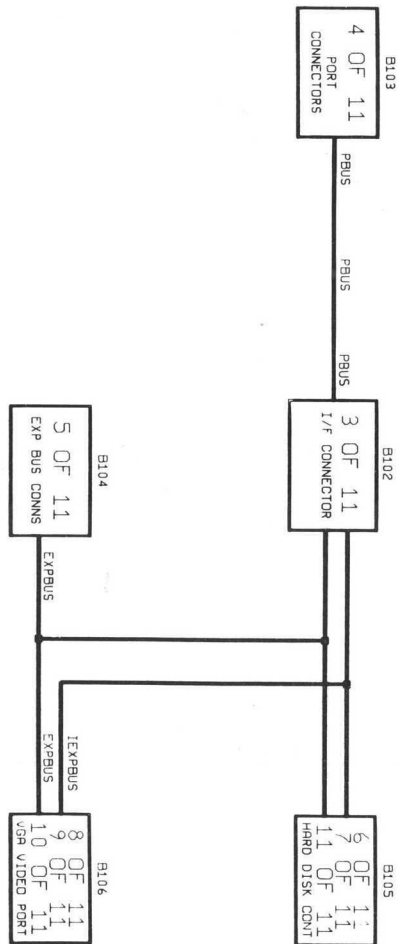

CHASSIS SCHEMATIC DIAGRAM

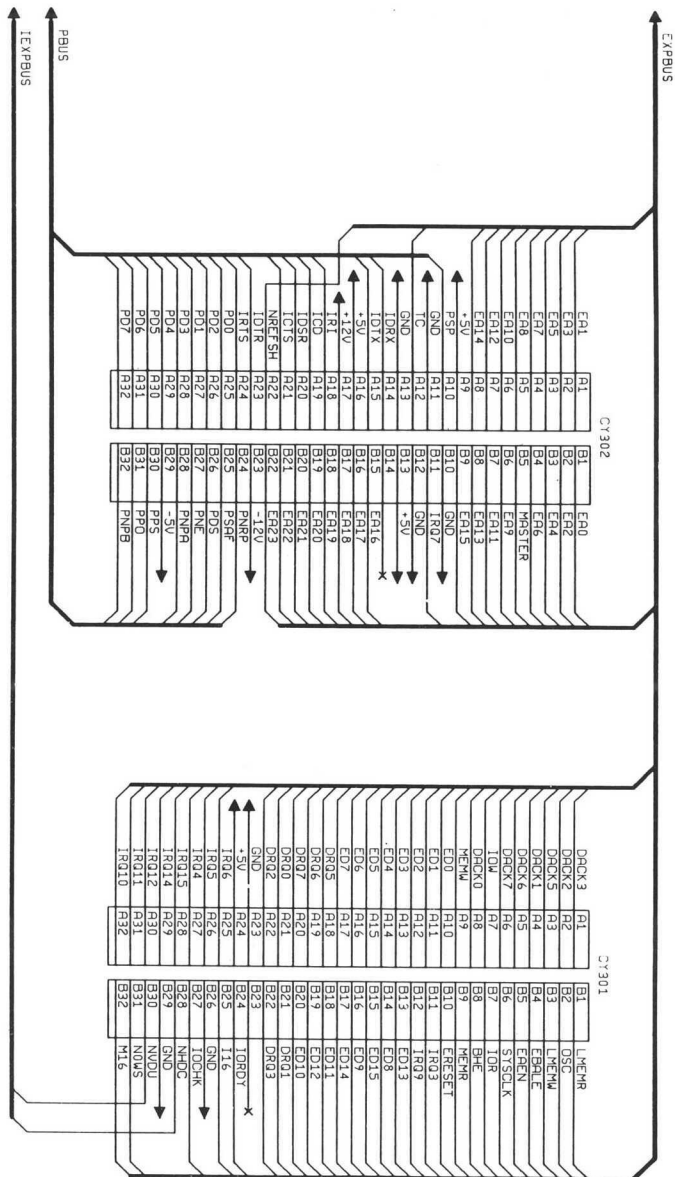

NOTE: THIS SCHEMATIC DIAGRAM IS THE LATEST AT THE TIME OF PRINTING AND SUBJECT TO CHANGE WITHOUT NOTICE

CHASSIS SCHEMATIC DIAGRAM

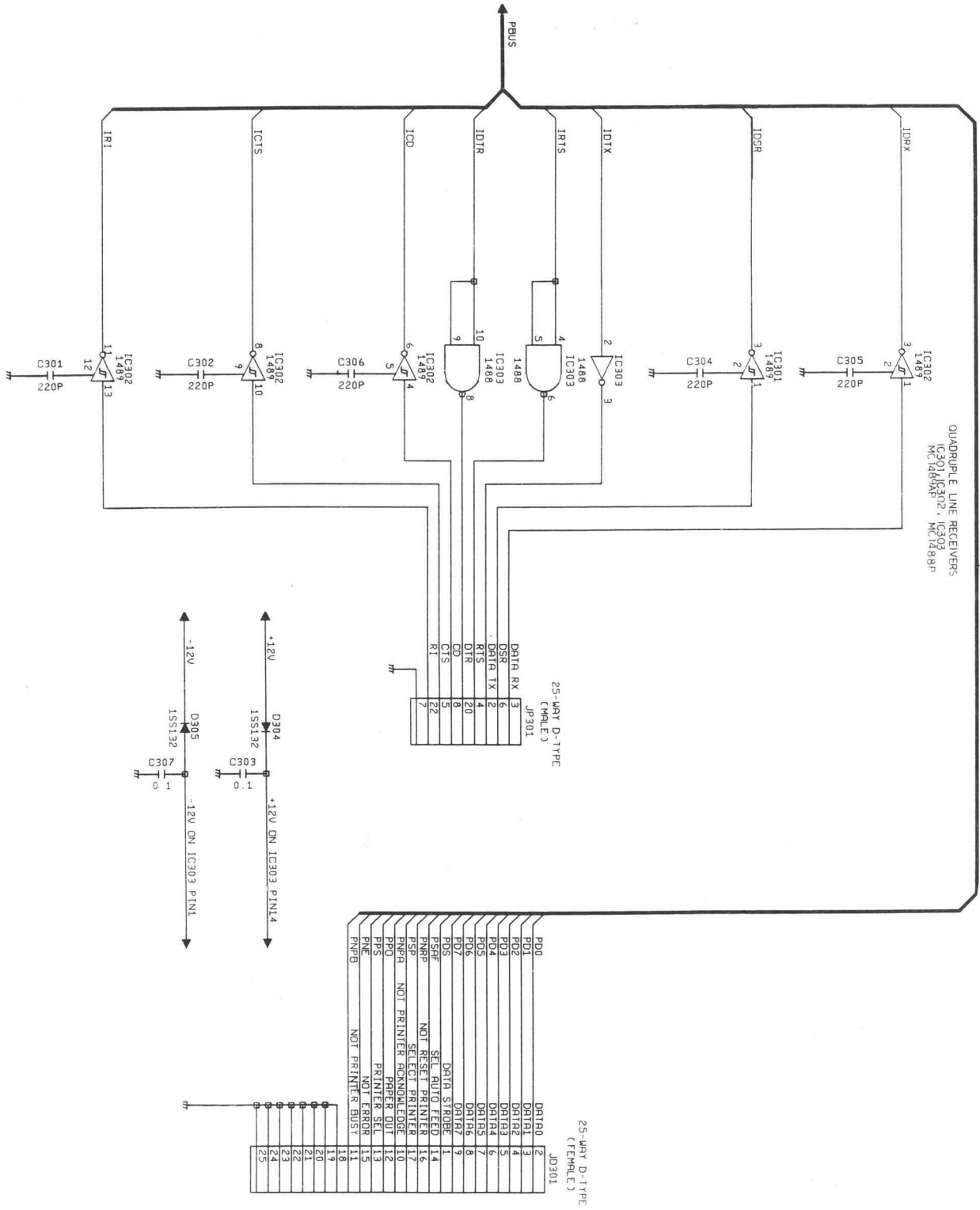

NOTE: THIS SCHEMATIC DIAGRAM IS THE LATEST AT THE TIME OF PRINTING AND SUBJECT TO CHANGE WITHOUT NOTICE.

CHASSIS SCHEMATIC DIAGRAM

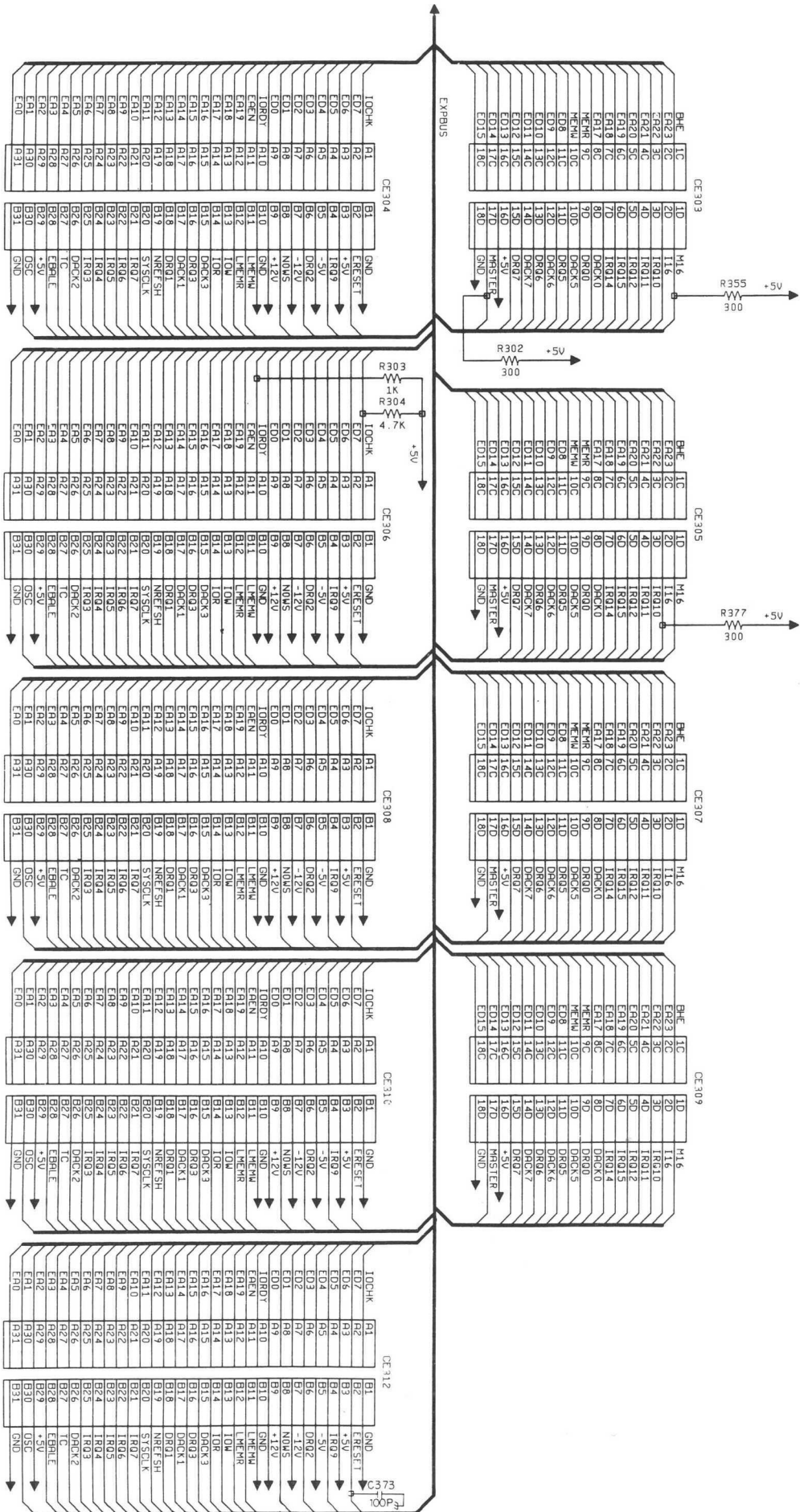

NOTE: THIS SCHEMATIC DIAGRAM IS THE LATEST AT THE TIME OF PRINTING AND SUBJECT TO CHANGE WITHOUT NOTICE.

CHASSIS SCHEMATIC DIAGRAM

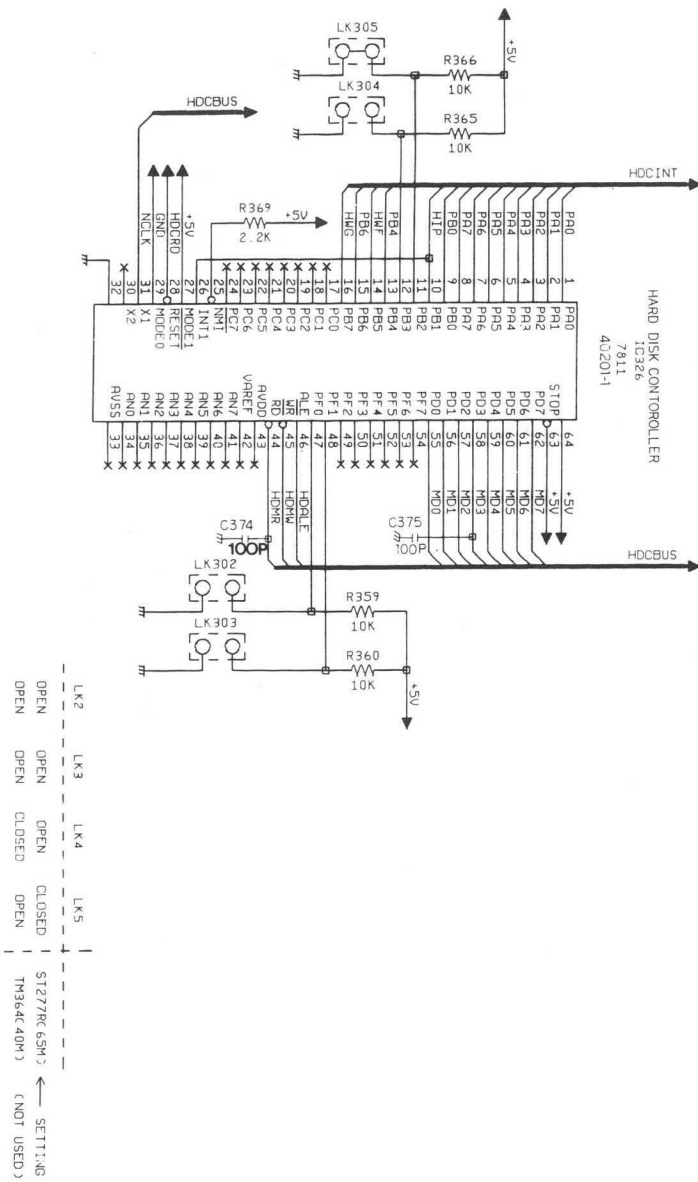

NOTE: THIS SCHEMATIC DIAGRAM IS THE LATEST AT THE TIME OF PRINTING AND SUBJECT TO CHANGE WITHOUT NOTICE.

CHASSIS SCHEMATIC DIAGRAM

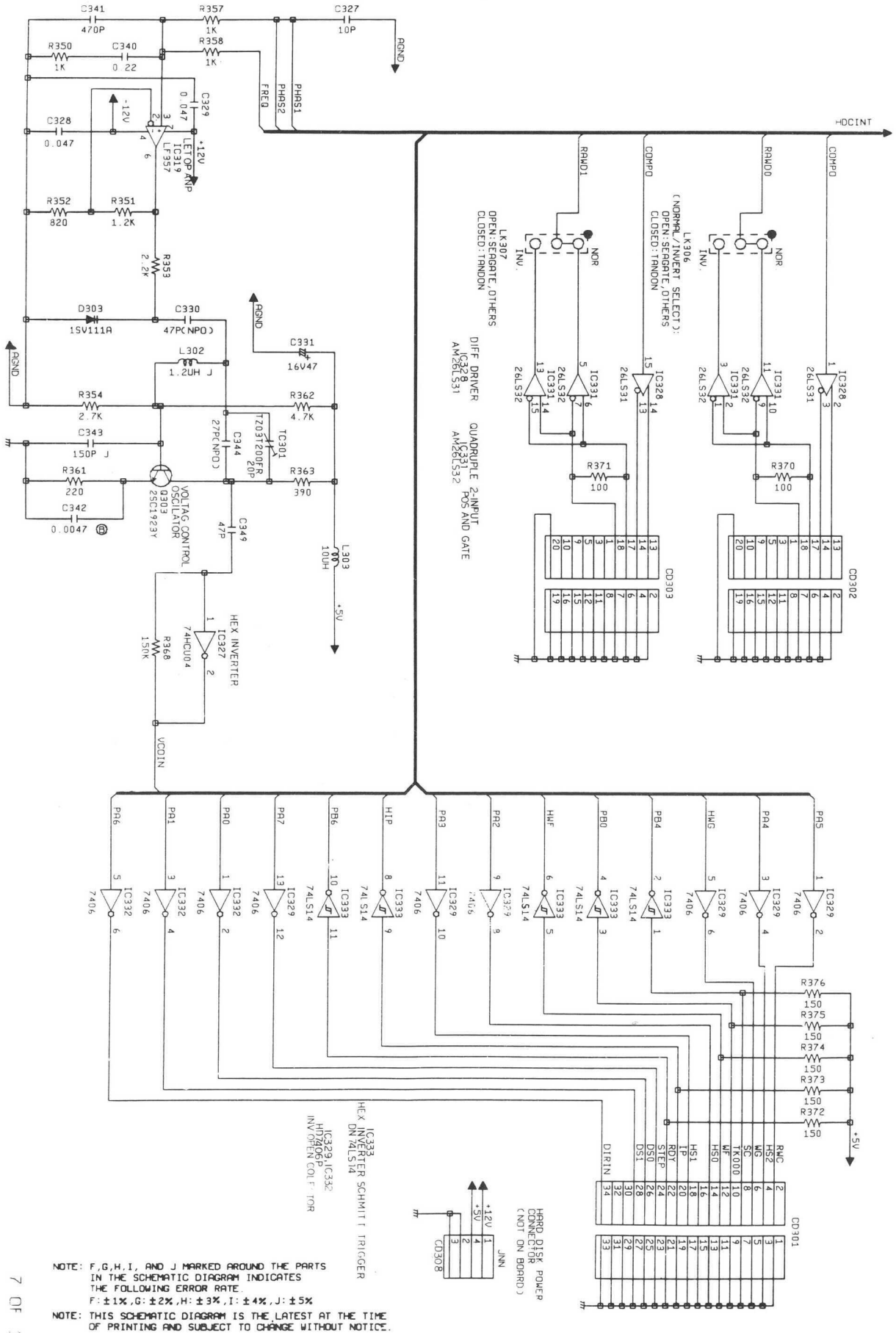

7 OF 11

NOTE: F, G, H, I, AND J MARKED AROUND THE PARTS IN THE SCHEMATIC DIAGRAM INDICATES THE FOLLOWING ERROR RATE:
 F: ±1%, G: ±2%, H: ±3%, I: ±4%, J: ±5%

NOTE: THIS SCHEMATIC DIAGRAM IS THE LATEST AT THE TIME OF PRINTING AND SUBJECT TO CHANGE WITHOUT NOTICE.

CHASSIS SCHEMATIC DIAGRAM

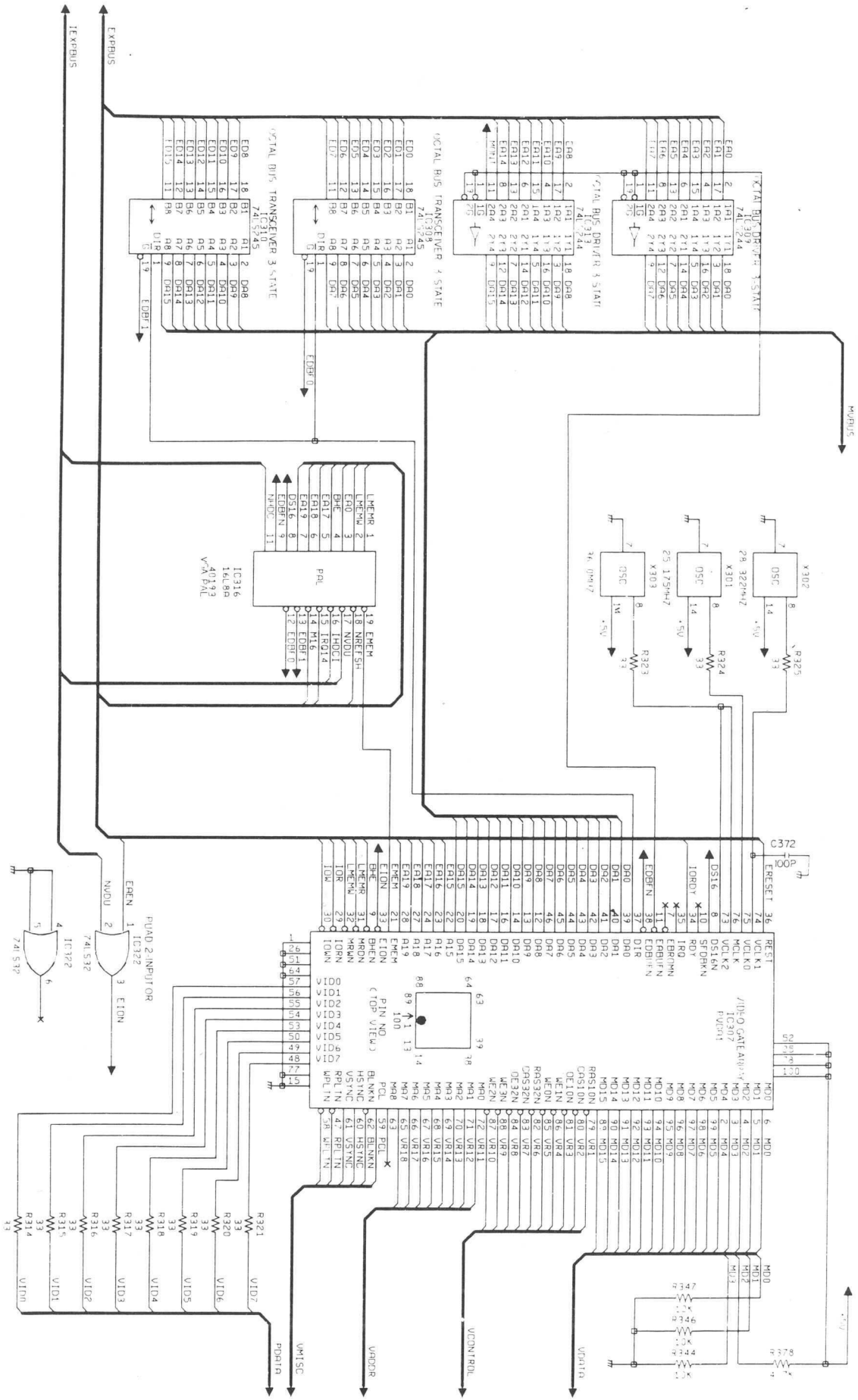

NOTE: THIS SCHEMATIC DIAGRAM IS THE LATEST AT THE TIME OF PRINTING AND SUBJECT TO CHANGE WITHOUT NOTICE.

2-3244

8 OF 11

CHASSIS SCHEMATIC DIAGRAM

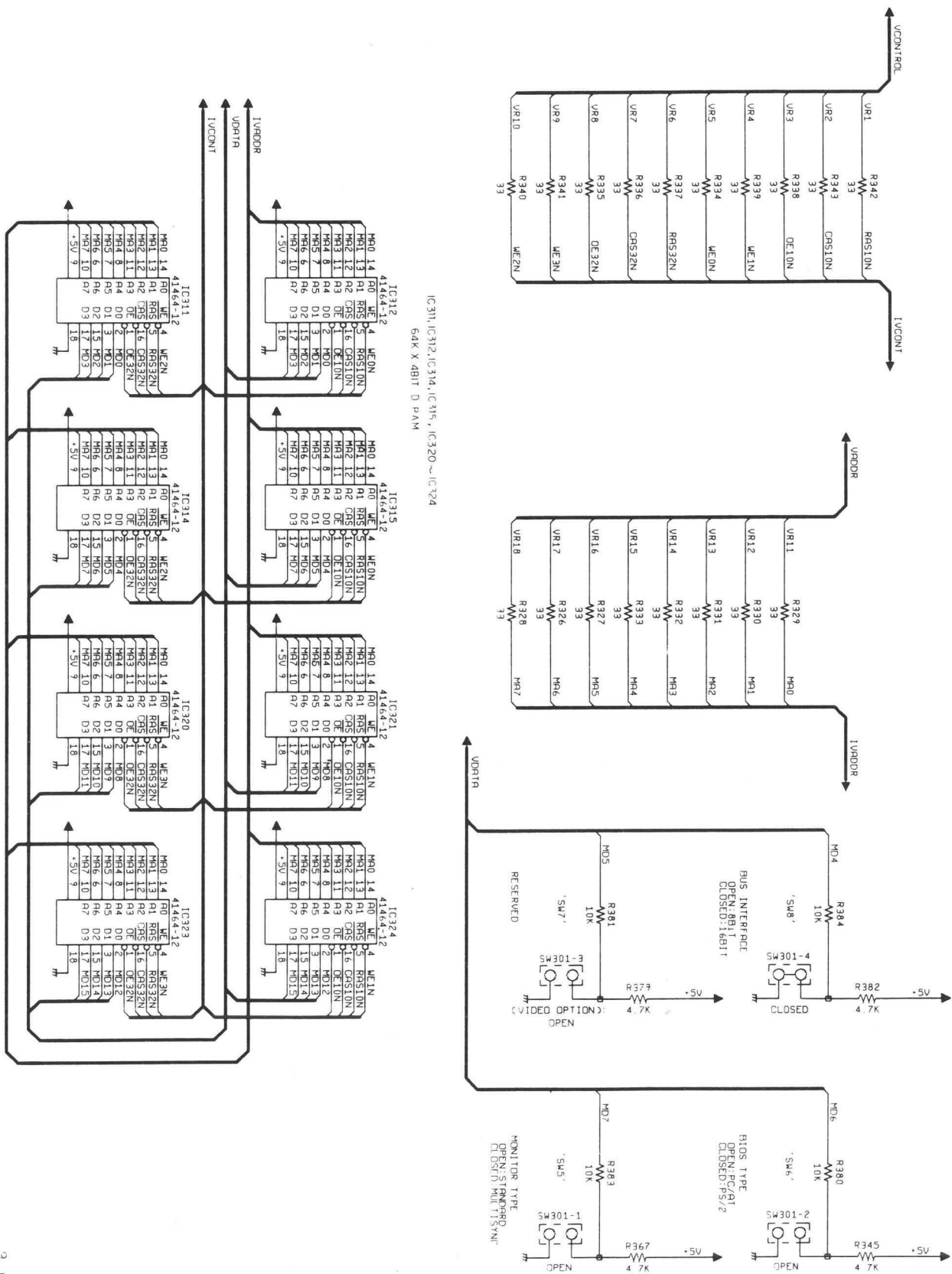

IC311, IC312, IC314, IC315, IC320 ~ IC324
64K X 4BIT 0 PAM

NOTE: THIS SCHEMATIC DIAGRAM IS THE LATEST AT THE TIME OF PRINTING AND SUBJECT TO CHANGE WITHOUT NOTICE.

CHASSIS SCHEMATIC DIAGRAM

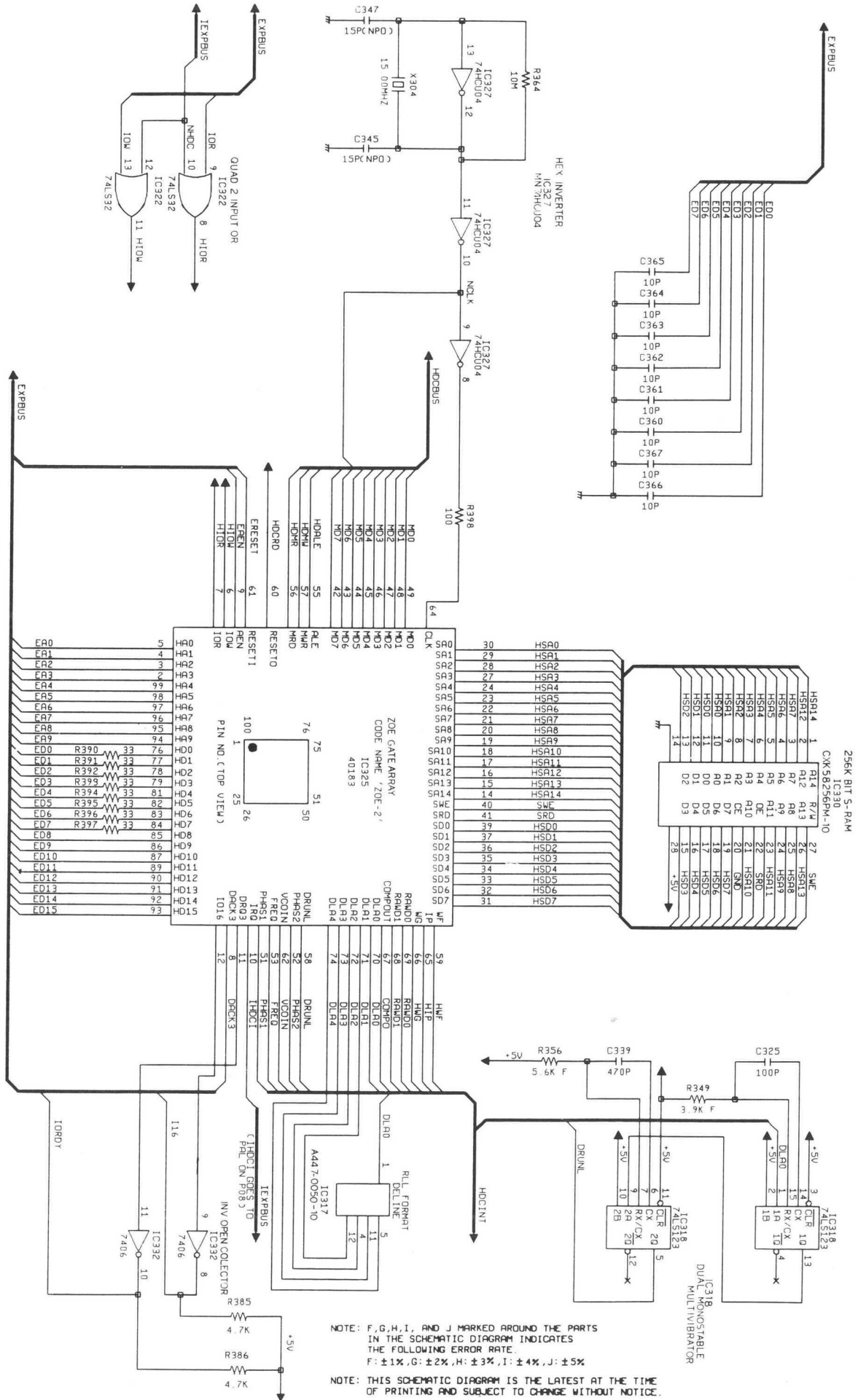

NOTE: F, G, H, I, AND J MARKED AROUND THE PARTS IN THE SCHEMATIC DIAGRAM INDICATES THE FOLLOWING ERROR RATE:
F: ±1%, G: ±2%, H: ±3%, I: ±4%, J: ±5%

NOTE: THIS SCHEMATIC DIAGRAM IS THE LATEST AT THE TIME OF PRINTING AND SUBJECT TO CHANGE WITHOUT NOTICE.

CHASSIS SCHEMATIC DIAGRAM I

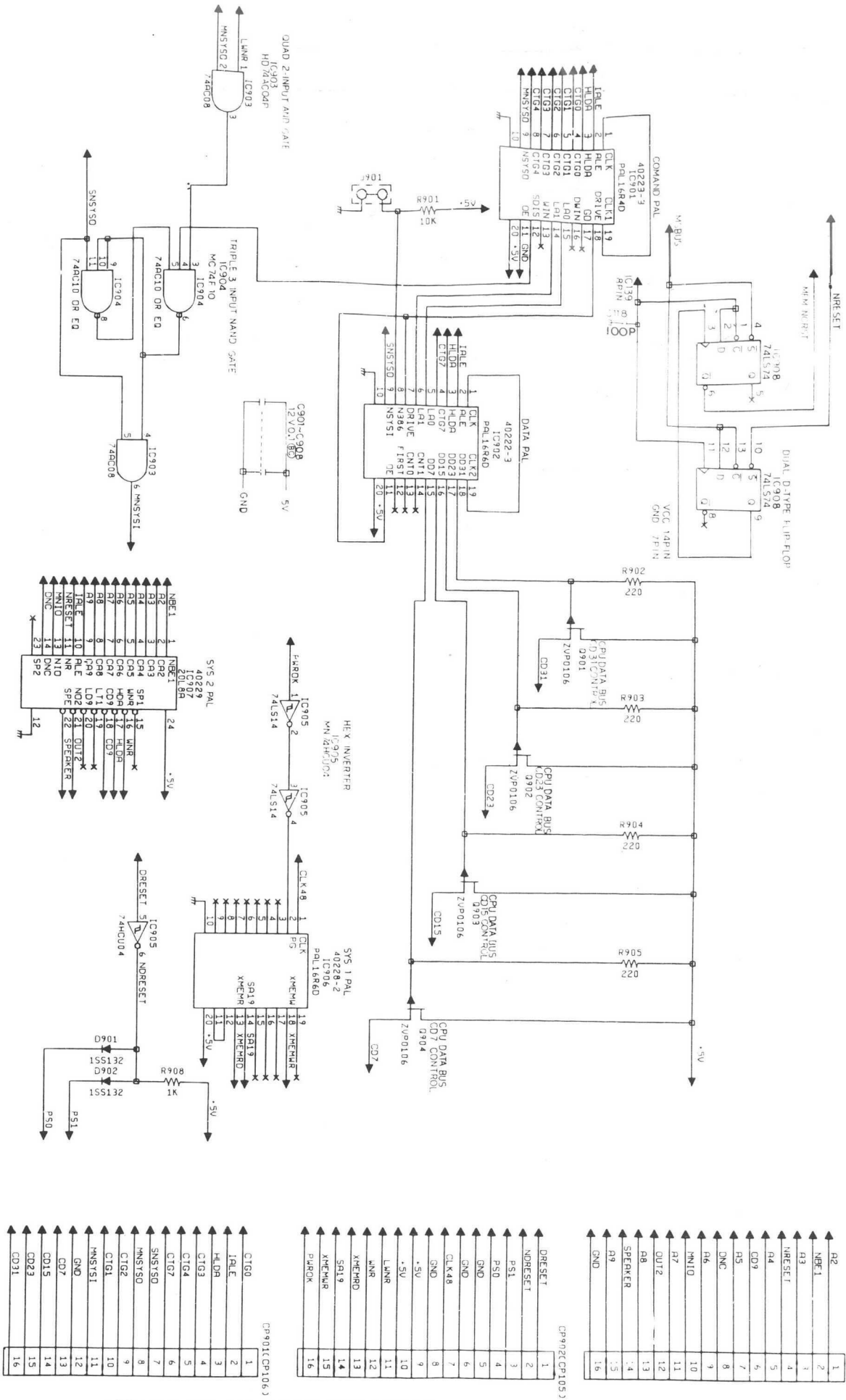

NOTE: THIS SCHEMATIC DIAGRAM IS THE LATEST AT THE TIME OF PRINTING AND SUBJECT TO CHANGE WITHOUT NOTICE.

KEYBOARD CHASSIS SCHEMATIC DIAGRAM

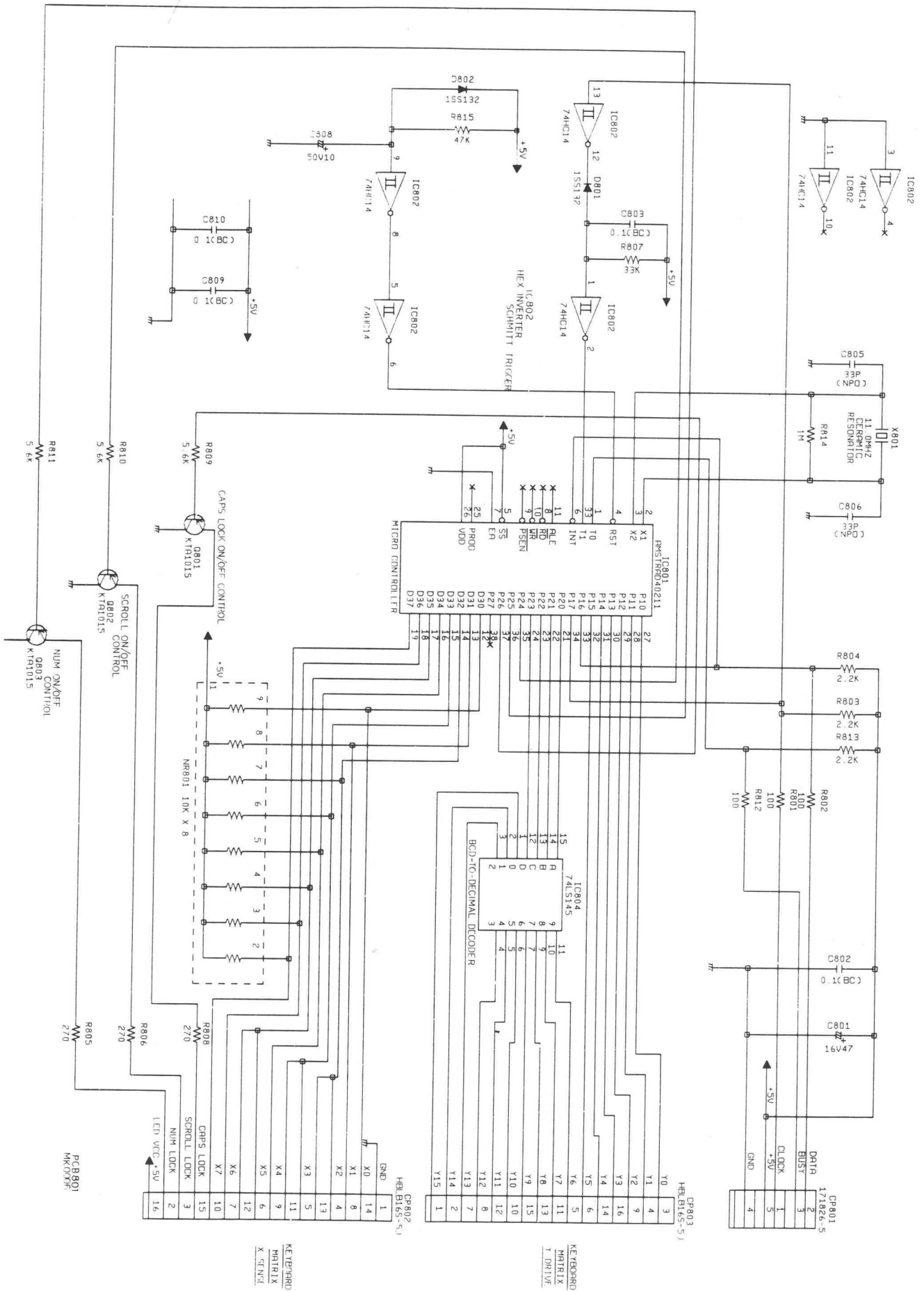

NOTE: THIS SCHEMATIC DIAGRAM IS THE LATEST AT THE TIME OF PRINTING AND SUBJECT TO CHANGE WITHOUT NOTICE.

KEYBOARD CHASSIS SCHEMATIC DIAGRAM

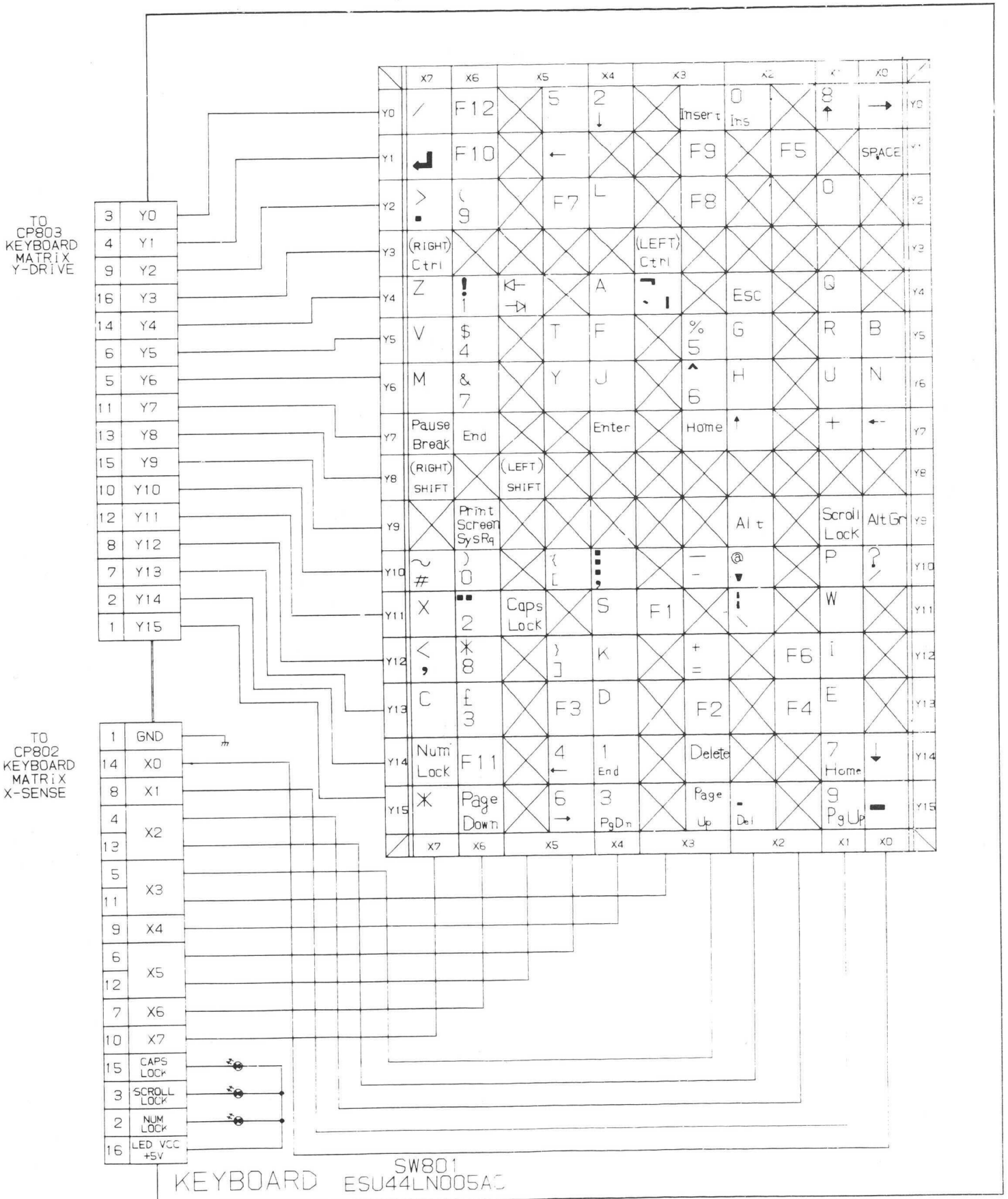

ELECTRICAL PARTS LIST

Circ. Ref.	Description	Part No.
PCBs		
PCB101	PCB MC0076 Main PCB	176674
PCB106	PCB MC0086 Memory PCB	176675
PCB107	PCB MC0087 Memory PCB	176676
PCB201	PCB MS0142 F.D. Expansion PCB	176677
PCB301	PCB MC0075 Expansion PCB	176678
PCB302	PCB MS0146 LED PCB	176679
PCB303	PCB MS0147 LED PCB	176680
PCB601	PCB MP0001 Power Supply PCB	176681
PCB801	PCB MK0006 KBD PCB	176682
PCB802	PCB MS0143 Lock Key PCB	176683
PCB901	PCB MS0140 Debug PCB	176684
Jacks		
JD102	Socket DIN	176669
JD202	Jack DIN	176160
Switches		
SW102	Switch Puch ESE-153A	176100
SW201	Switch Slide 22DP	176101
SW301	Switch Dip	176670
SW601	Switch Puch Power	176102
SW801	Switch Keyboard	176671
Variable Resistors		
VR401	VROT 20k Volume Control	176104
VR601	VRSF 100kΩ	176672
VR603, 604, 606	VRSF 1kΩ	176673
Coils		
L301	Coil 4.7mH	176663
L302	Coil 1.2uH	176664
L303	Coil 10uH	176665
L601	Coil Line Filter	176666
L602	Coil 020F000003	176093
T601	Transformer Switching 8142022	176667

Circ. Ref.	Description	Part No.
IC's		
IC001-009	IC KM41C1000-10	176623
IC101	IC AMS40187	40187
IC102	IC DN74LS175	176085
IC103, 108, 113	IC DN74LS138	176624
IC104, 140	IC DN74LS125A	176625
IC105	IC DN74LS08	176626
IC106, 107	IC SN7438	176627
IC109, 110, 117, 142, 333	IC DN74LS14	171389
IC112	IC SED9420CAC	171034
IC114	IC AMS40188	40188
IC115	IC MC146818P	176063
IC116, 130, 131, 133, 134, 137, 309	IC DN74LS244	171383
IC118, 129, 143, 144	IC DN74LS374	176628
IC119	IC HD74AC08P	174031
IC120	IC Z765APS	176048
IC121, 123-127, 308, 310	IC DN74LS245	171393
IC122	IC DN74LS148	176629
IC128	IC DN74LS240	176630
IC132	IC AMS40130	40130
IC135	IC HD7406P	176042
IC136	IC DN74LS174	176631
IC138, 147, 148	IC DN74F373	176632
IC139, 327, 905	IC MN74HCU04	40008/A
IC141	IC DN74LS05	176633
IC146	IC AMS386	176600
IC149	IC AMS40129	40129
IC151-153	IC UPD421000LA-10*9PCS	176634
IC154	IC AMS40195 Delay Line	40195
IC155	IC AMS40194 Delay Line	40194
IC156	IC AMS40192	40192
IC157	IC AMS40191 ROS	40191
IC158	IC AMS40190 ROS	40190
IC159	IC AMS40189 ROS	40189
IC160-170	IC HM6789P-30	176639
IC301, 302	IC MC1489AP	171379
IC303	IC MC1488P	171378
IC304	IC LA6339D	176640
IC305	IC IMSG171P-35	176074
IC307	IC PVGA1 Video Gate Array	176071
IC311, 312, 314, 315, 320, 321, 323, 324	IC KM41464-12	176641
IC316	IC AMS40193	40193
IC317	IC A447-0050-10 Delay Line	176651
IC318	IC DN74LS123	176642
IC319	IC LF357	176643
IC322	IC DN74LS32	176644
IC325	IC AMS40183	40183
IC326	IC AMS40201-1	40201
IC328	IC AM26LS31PC	176645
IC329, 332	IC HD7406P	176042
IC330	IC CXK58256PM-10	176646
IC331	IC AM26LS32PC	176647
IC401	IC LA4140	170111
IC601	IC STK7458	176648
IC602	IC MB3761M	176649
IC603	IC LA6324	170112
IC604	IC BA707	171481
IC605	IC BA6993	171480
IC606	IC AN7905F	176652
IC607	IC AN7912T	176653
IC801	IC AMS40211	40211
IC802	IC MN74HC14	176654
IC804	IC DN74LS145	176655
IC901	IC AMS40223-3	40223
IC902	IC AMS40222-3	40222
IC903	IC HD74AC08P	174031
IC904	IC MC74F10	176656
IC906	IC AMS40228-2	40228
IC907	IC AMS40229	40229
IC908	IC DN74LS74A	176658

ELECTRICAL PARTS LIST

Circ. Ref.	Description	Part No.
Transistors		
Q101, 104, 106, 801-803	TR KTA1015Y	170453
Q102, 103, 105, 301, 302, 606, 616	TR KTC1815Y	170447
Q303	TR 2SC1923Y	202201
Q601	TR 2SA1346-AC Compound TR.	176660
Q602	TR Photo TLP732 (LF2)	176087
Q603	TR Photo TLP741G (LF2)	176659
Q614	TR 2SB1135R	176661
Q615	TR 2SD1207-AE	170741
Q901-904	TR ZVP0106A	176662

Circ. Ref.	Description	Part No.
Diodes		
D101-104, 304, 305, 620, 801, 802, 901, 902	D 1SS132T-77	171582
D105, 106	DZ GZA6.8Y	175636
D301	LED SLP-155B	170866
D302	LED SLP-255B	176028
D303	D 1SV111A	176616
D601-604	D 20E10FA13	176039
D605, 606	DZ GZA51 Y BT	176617
D607, 608	D 1NU41 (LC6)	176618
D609, 615	D DFD05TG-BT	176035
D610	DZ GZA36 Y BT	176619
D611	DZ GZA18 Y BT	176033
G612, 621	D 1DL41 (TPA3)	176620
D614	D F10P20F	176621
D616	D 30 GWJ2C42	176622
D618	DZ GZA5.1 Y BT	176038
D619	DZ GZA5.6 Y BT	171499

Circ. Ref.	Description	Part No.
Miscellaneous		
B101	Ferrite Bead	174058
B601-605	Ferrite Bead	176114
FDD201	Floppy Disc Drive OSDA-45A	176724
HDD201	Hard Disc Drive ST277R	176725
M601	Fan Motor	176732
NR101, 102	Resnet 4.7kΩ X8	176167
NR103, 104	Resnet 2.2kΩ X8	176166
NR801	Resnet 10kΩ X8	176169
SP401	Speaker	171370
TC101, 301	Trimmer Capacitor 20pF	176171
TH601	Thermistor Power	176733
TH602	Thermistor	176172
X101	XTAL 1.8432 MHz	176173
X102	XTAL 32.768kHz	176174
X103	XTAL 48.0MHz	176734
X104	XTAL 14.318MHz	176735
X105	XTAL 40.0MHz	176736
X301	XTAL 25.175MHz	176179
X302	XTAL 28.322MHz	176178
X303	XTAL 36.00MHz	176180
X304	XTAL 15.00MHz	176181
X801	XTAL 11.0MHz	173737

Description	Circ. Ref.	Part No.
Carbon Film Resistors (All 1/6W)		
100Ω	R659	152166
330Ω	R663	152172
470Ω	R654	152174
680Ω	R649, 650, 655	152176
820Ω	R664	152178
3.3kΩ	R660	152185
4.7kΩ	R608	152188
10kΩ	R607	152194
12kΩ	R605	152195
15kΩ	R666	152196
27kΩ	R606	152199
100kΩ	R657	152209
1MΩ	R611, 615	152223

Description	Circ. Ref.	Part No.
Carbon Film Resistors (All 1/4W)		
56Ω	R656	10024
470Ω	R626	10048
100Ω	R638, 648	10032
1kΩ	R633, 643, 644, 646, 658, 661	10061
5.6kΩ	R639	10079
10kΩ	R647	10085
15kΩ	R665	10089
330kΩ	R612	10121
820kΩ	R614	10130

Description	Circ. Ref.	Part No.
Carbon Film Resistors (All 1/2W)		
100Ω	R667	176377
270Ω	R610	176748
2.7kΩ	R624, 625, 627, 628	176749
4.7kΩ	R662	176750

Description	Circ. Ref.	Part No.
Metal Oxide Resistors		
0.22Ω 1W	R635, 636	176745
100Ω 2W	R634	176744
560Ω 3W	R618	176743
1kΩ 2W	R617	176742
33kΩ 3W	R603	176740
68kΩ 2W	R601, 604	176738

Description	Circ. Ref.	Part No.
Cement Resistors		
0.05Ω 5W	R640, 641	176746
0.22Ω 5W	R609	176741

Description	Circ. Ref.	Part No.
Fuse Resistors		
4.7kΩ	R602	176739

Description	Circ. Ref.	Part No.
Ceramic Capacitors		
470pF 2kV	C609	176751
820pF 500V	C626	176752
2200pF	C606	176304
4700pF 2kV	C608	176753
0.001μF	C611, 616	24027
0.0015μF	C612	1400223
0.0022μF 500V	C624	176754
0.0022μF 2kV	C603-605	171646
0.01μF	C613, 618	176755

Description	Circ. Ref.	Part No.
Electrolytic Capacitors		
1μF/50V	C617	20062
2.2μF/50V	C638	175114
3.3μF/50V	C607	176346
10μF/16V	C637	20148
10μF/25V	C633	20037
47μF/16V	C621	20027
47μF/25V	C622	151640
47μF/50V	C610	176348
100μF/10V	C639	20028
100μF/16V	C632	20028
100μF/50V	C635, 636	176320
330μF/35V	C630	176321
330μF/63V	C623	176756
330μF/400V	C601	176757
1000μF/16V	C629, 640	1422158
3300μF/35V	C625	171655
6800μF/16V	C627, 628	176758

Description	Circ. Ref.	Part No.
Polyester Capacitors		
0.033μF	C631, 634	176311
0.1μF	C614, 615	175899

Description	Circ. Ref.	Part No.
Metal Plastic Capacitors		
0.1μF 250V AC	C602	171658

KEYBOARD EXPLODED VIEW
(For Parts List please refer to Page 47.)

