

Kundendienst-Handbuch Service Manual

PERSONAL COMPUTER PC 2640

Ident-Nr.: 36523



Exploded view

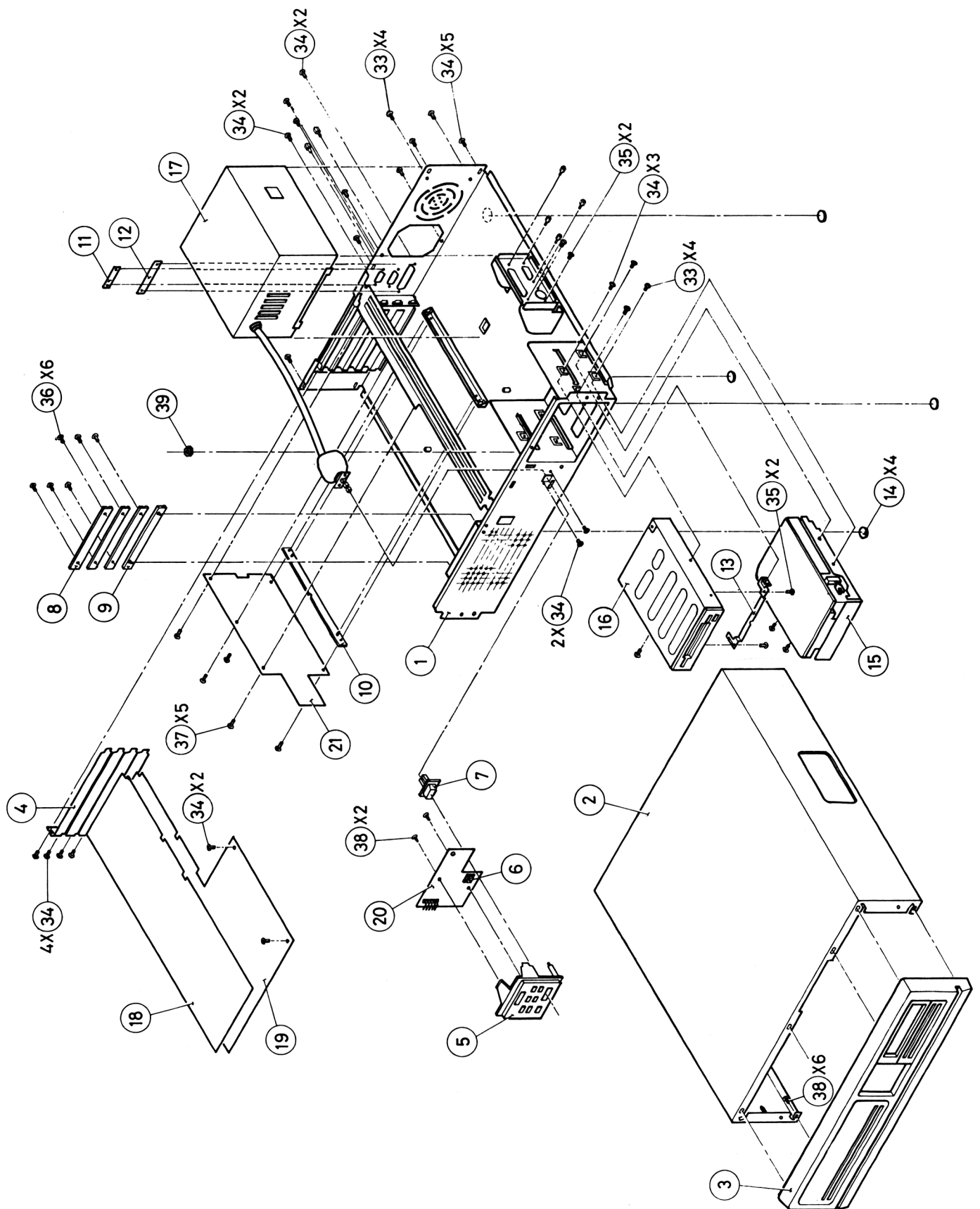

Ersatzteilliste für PC 2640
Parts List for Model PC 2640

Best.-Nr. Part.-No.	Bezeichnung	Description	Zeichen-Pos. Ref.-No.	Preisgruppe
40 894 00	Gehäuse Boden	Bottom case	1	E 5
40 895 00	Gehäuse Oberteil	Top case	2	E 0
40 896 00	Frontrahmen	PC 2640 Front panel	3	B 7
40 897 00	Abdeckung LED	LED cover	5	B 1
40 898 00	Knopf Reset	Reset knob	6	A 5
40 899 00	Knopf Netzschalter	Power knob	7	A 5
40 900 00	Halter FDD	FDD bracket	13	A 7
40 888 00	Keyboard kompl.	Keyboard assembly	-	F 6
40 873 00	Maus	Mouse	-	E 2
40 901 00	Styropor Systemeinheit, Satz	Polyfoam system unit, set	-	D 1
40 902 00	Faltkarton Systemeinheit	Gift box system unit	-	B 7
40 903 00	Styropor Keyboard, Satz	Polyfoam keyboard, set	-	B 7
40 904 00	Faltkarton Keyboard	Gift box keyboard	-	B 2
40 905 00	Faltkarton Keyboard kompl.	Gift box keyboard cpl.	-	B 3
44 013 00	Netzkabel	Cord AC	-	C 5
44 014 00	Kabel HDD	Cable HDD	22	B 5
44 015 00	Kabel HDD	Cable HDD	23	B 2
44 016 00	Kabel FDD	Cable FDD	24	B 4
44 017 00	Kabel FDD	Cable FDD	25	C 7
44 018 00	Kabel Leiste	Cable male	26	B 5
44 019 00	Kabel LED	Wire LED	27	B 5
44 020 00	Kabel Display	Wire display	28	A 5
44 021 00	Kabel Buchse	Cable D-jack	29	B 1
44 022 00	Kabel FDD	Wire power FDD	30	B 0
44 023 00	Kabel FDD	Wire power FDD	31	B 2

Exploded view keyboard

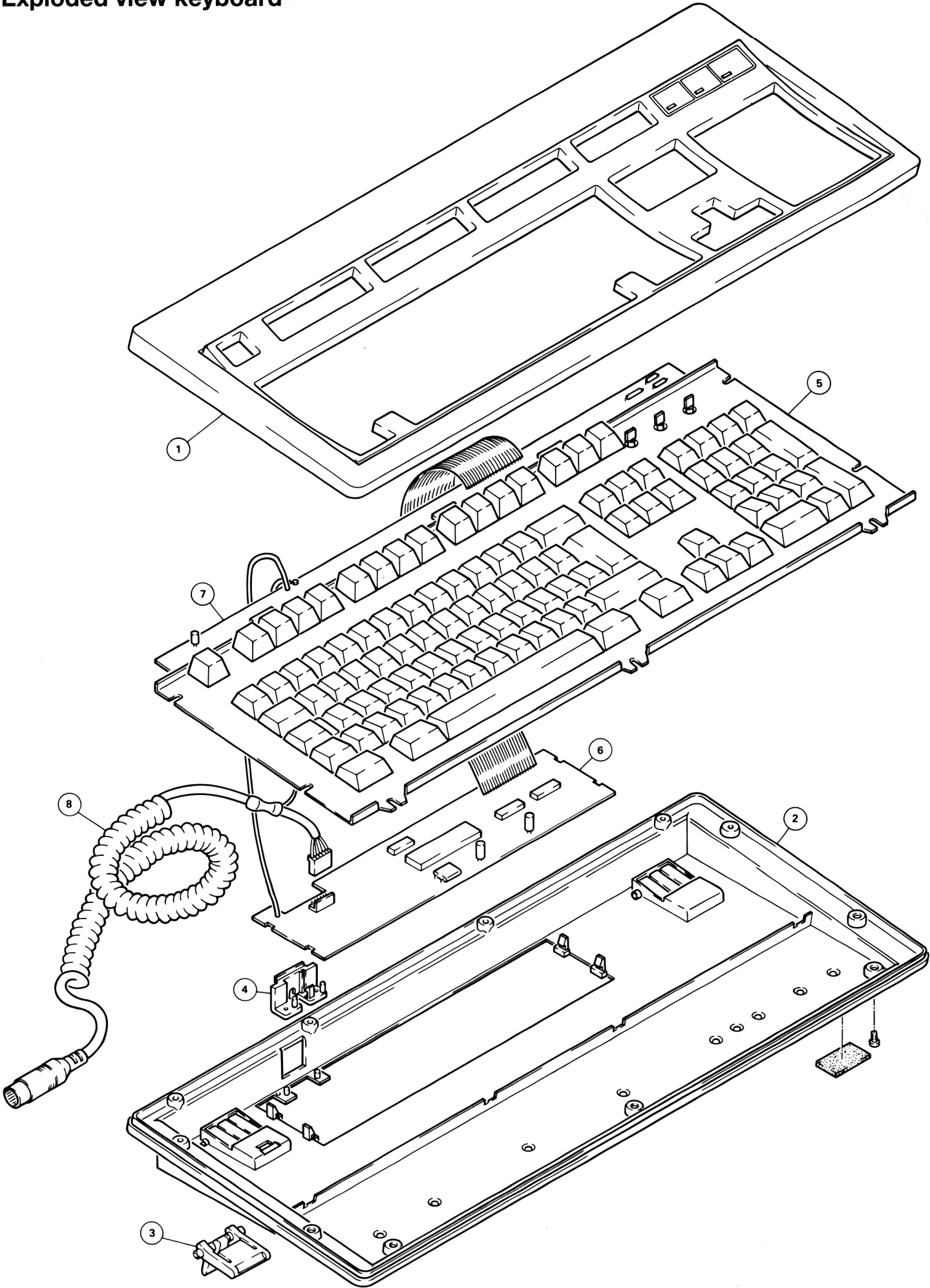

Wiring diagram

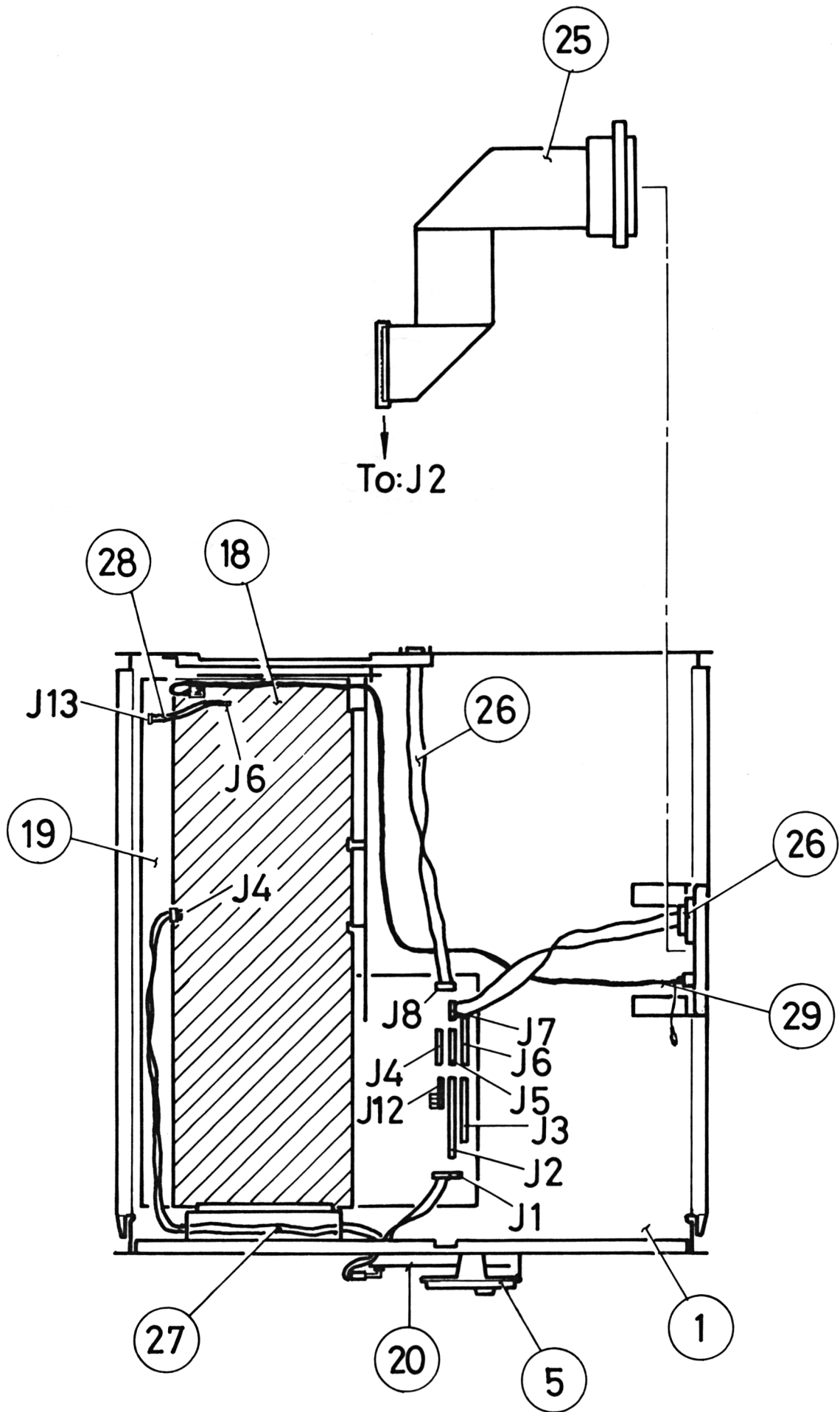

Wiring diagram

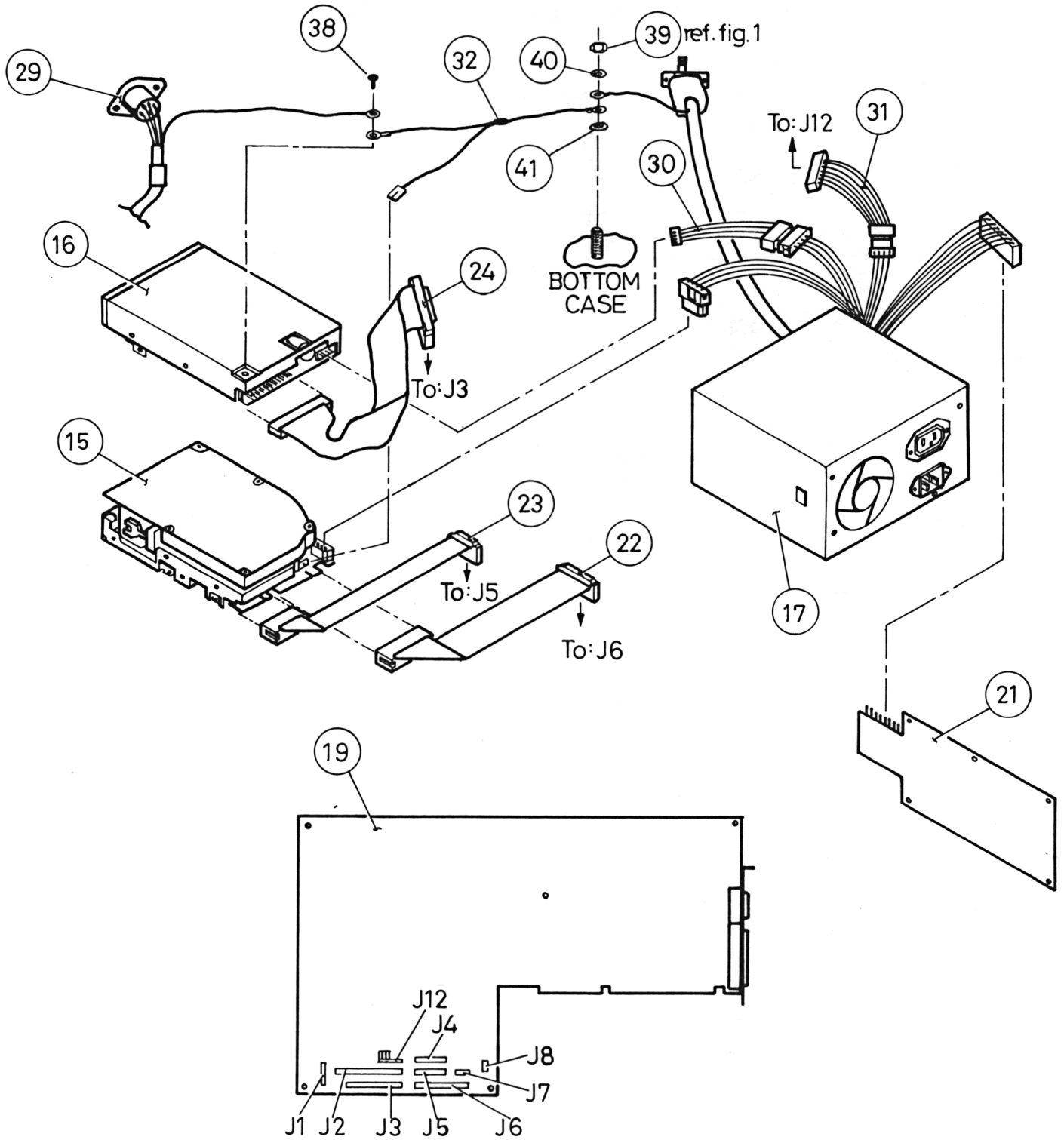

Ersatzteilliste für PC 2640
 Parts List for PC 2640

Best.-Nr. Part.-No.	Bezeichnung	Description	Zeichen-Pos. Ref.-No.	Preisgruppe
40 980 00	Platine LED	LED board	-	C 5
IC				
24 185 00	IC NE 555 P	IC NE 555 P	U 1	B 4
40 981 00	IC NE 558 N	IC NE 558 N	U 2	A 7
15 241 00	IC 7406	IC 7406	U 3	A 7
Verschiedenes/Miscellaneous				
40 992 00	Widerstand/Netzwerk	Resistor, Network	RP 1	A 3
40 997 00	Widerstand/Netzwerk	Resistor, Network	RP 2, 3	A 3

**Block Diagram
LED board**

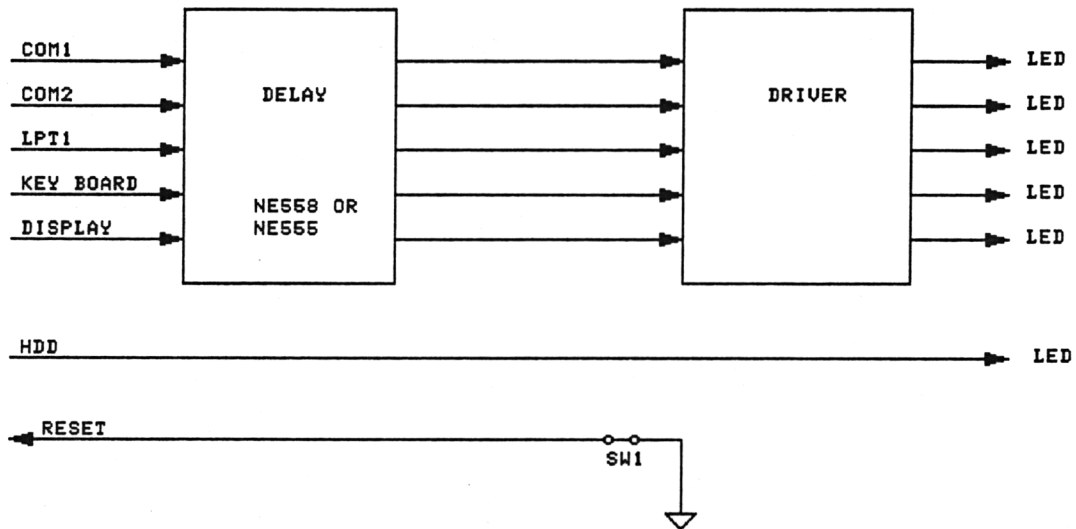

LED Board

Schematic diagram

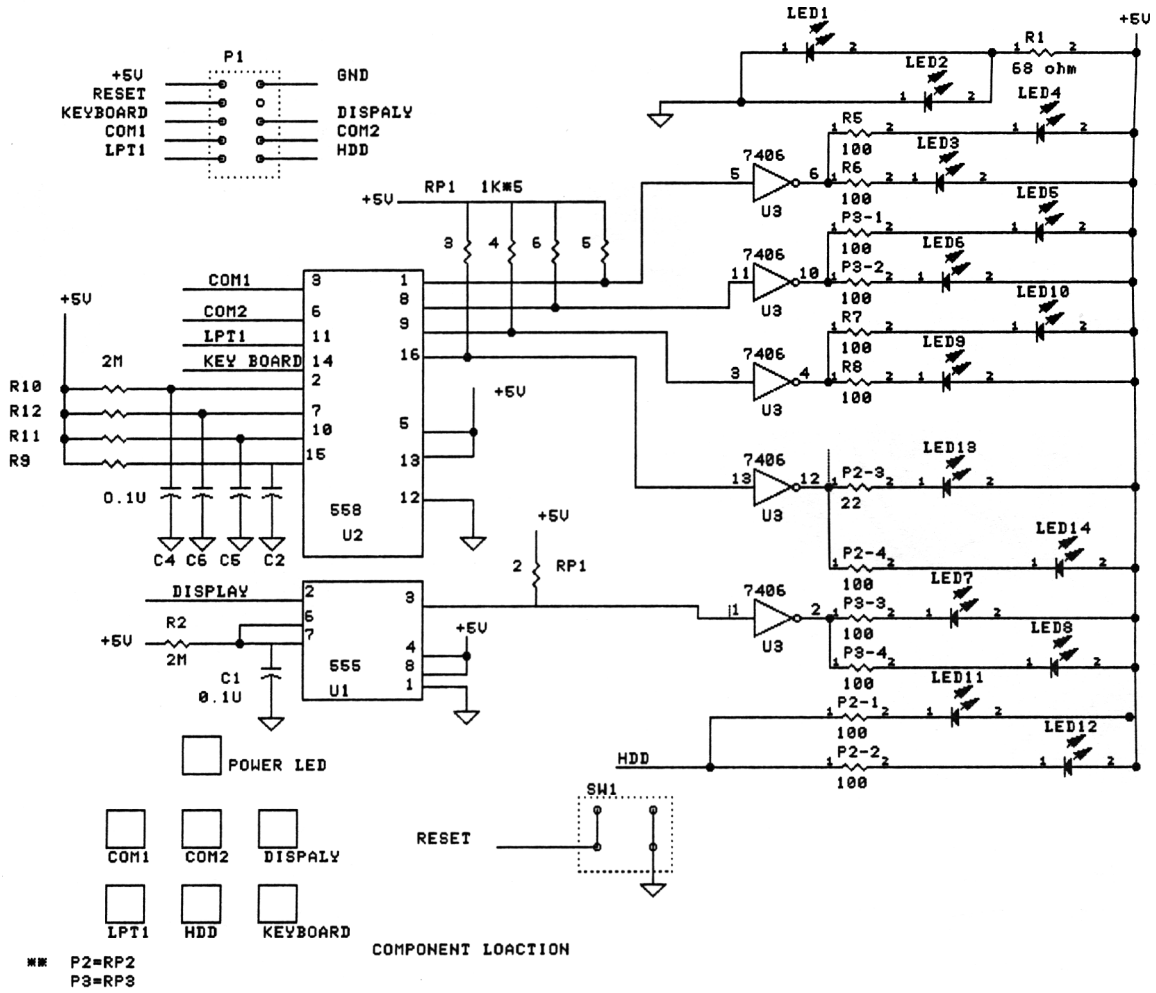

Component side

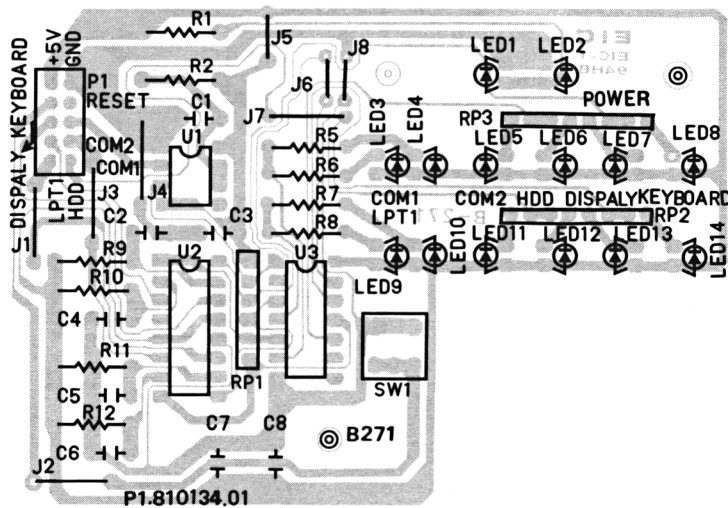

Ersatzteilliste für PC 2640 CPU
Parts List for PC 2640 CPU

Best.-Nr. Part.-No.	Bezeichnung	Description	Zeichen-Pos. Ref.-No.	Preisgruppe
40 906 00	Platine CPU	CPU board	-	*
IC				
40 907 00	IC 41256-12	IC 41256-12	U 1-9	C 8
40 908 00	IC 74 LS 10	IC 74 LS 10	U 10	A 4
40 909 00	IC 74 F 153	IC 74 F 153	U 11	A 8
40 910 00	IC 41256-12	IC 41256-12	U 12-20	C 8
40 908 00	IC 74 LS 10	IC 74 LS 10	U 21	A 4
40 912 00	IC 4164-12	IC 4164-12	U 23-31	C 2
40 913 00	IC 80C42C	IC 80C42C	U 32	C 7
40 912 00	IC 4164-12	IC 4164-12	U 33-41	C 2
34 767 00	IC 74LS125	IC 74LS125	U 42	A 5
40 915 00	IC 74ALS27	IC 74ALS27	U 43	A 5
40 916 00	IC 27128-15	IC 27128-15	U 44	D 0
44 229 00	IC 27128-15	IC 27128-15	U 45	D 0
40 917 00	IC 74ALS138	IC 74ALS138	U 46	A 8
40 918 00	IC 74F00	IC 74F00	U 47	A 5
40 919 00	IC 74S112	IC 74S112	U 48	A 6
40 920 00	IC 82C202	IC 82C202	U 49	E 1
40 921 00	IC 82C206	IC 82C206	U 50	E 1
40 922 00	IC 82A203,12	IC 82A203,12	U 51	E 1
24 184 00	IC 14069	IC 14069	U 52	B 4
40 923 00	IC 82A205.12	IC 82A205.12	U 53	E 1
40 924 00	IC PAL20R6ANC	IC PAL20R6ANC	U 54	C 4
40 925 00	IC 74ALS244	IC 74ALS244	U 55	B 2
40 926 00	IC 82C201	IC 82C201	U 56	E 1
40 927 00	IC 74ALS04	IC 74ALS04	U 57	A 5
40 928 00	IC 74F08	IC 74F08	U 58	A 5
40 927 00	IC 74ALS04	IC 74ALS04	U 59	A 5
40 930 00	IC 7407	IC 7407	U 60	A 5
40 918 00	IC 74F00	IC 74F00	U 61	A 5
40 932 00	IC 74LS51	IC 74LS51	U 62	A 3
40 933 00	IC 80286-12	IC 80286-12	U 63	G 7
40 934 00	IC 82A204	IC 82A204	U 64	E 1
40 935 00	IC 74ALS573	IC 74ALS573	U 67, 68	B 4
40 936 00	IC 74ALS245	IC 74ALS245	U 69	B 2
Verschiedenes/Miscellaneous				
40 987 00	Widerstand/Netzwerk	Resistor, Network	RP 1	A 3
40 988 00	Widerstand/Netzwerk	Resistor, Network	RP 2, 3	A 3
40 989 00	Widerstand/Netzwerk	Resistor, Network	RP 4	A 3
40 990 00	Widerstand/Netzwerk	Resistor, Network	RP 5	A 3
40 987 00	Widerstand/Netzwerk	Resistor, Network	RP 6, 7	A 3
40 991 00	Widerstand/Netzwerk	Resistor, Network	RP 8	A 3
40 992 00	Widerstand/Netzwerk	Resistor, Network	RP 9	A 3
40 990 00	Widerstand/Netzwerk	Resistor, Network	RP 10, 11	A 3
40 993 00	Widerstand/Netzwerk	Resistor, Network	RP 12	A 3
40 990 00	Widerstand/Netzwerk	Resistor, Network	RP 13	A 3
40 998 00	Oszillator 12 MHz	Osc. 12 MHz	Y 1	B 5
40 999 00	Oszillator 25 MHz	Osc. 25 MHz	Y 2	B 5
44 000 00	Oszillator 20 MHz	Osc. 20 MHz	Y 3	B 5
44 001 00	Quarz 32,768 kHz	X Tal 32.768 kHz	X Tal 1	B 5
44 002 00	Quarz 14,318 kHz	X Tal 14.318 kHz	X Tal 2	B 5
44 009 00	Verzögerungsleitung	Delay line	U 22	B 5
44 010 00	Filter	EMI Absorber	R 13, 14, 18	B 1
44 025 00	Batterie 3,6 V	Battery 3.6 V	BAT	B 9
44 026 00	Piepser	Buzzer	BZ 1	B 3
44 027 00	DIP-SW 2fach	DIP-SW 2 pos.	SW 1	B 2

* Preis auf Anfrage

CPU Board

Block diagram

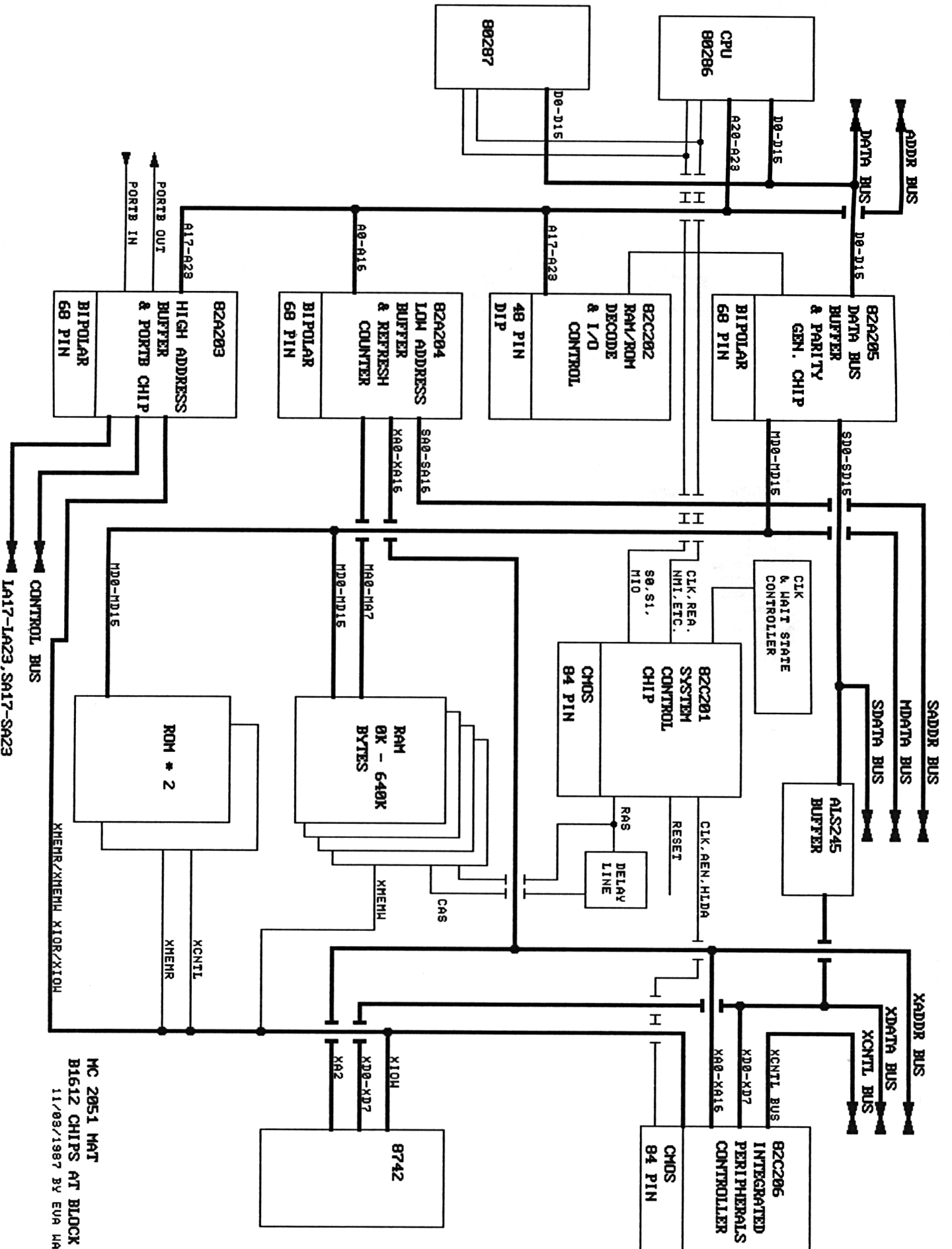

MC 2051 MAT
 B1612 CHIPS AT BLOCK DIAGRAM
 11/03/1987 BY EVA HANG

CPU Board

Component side

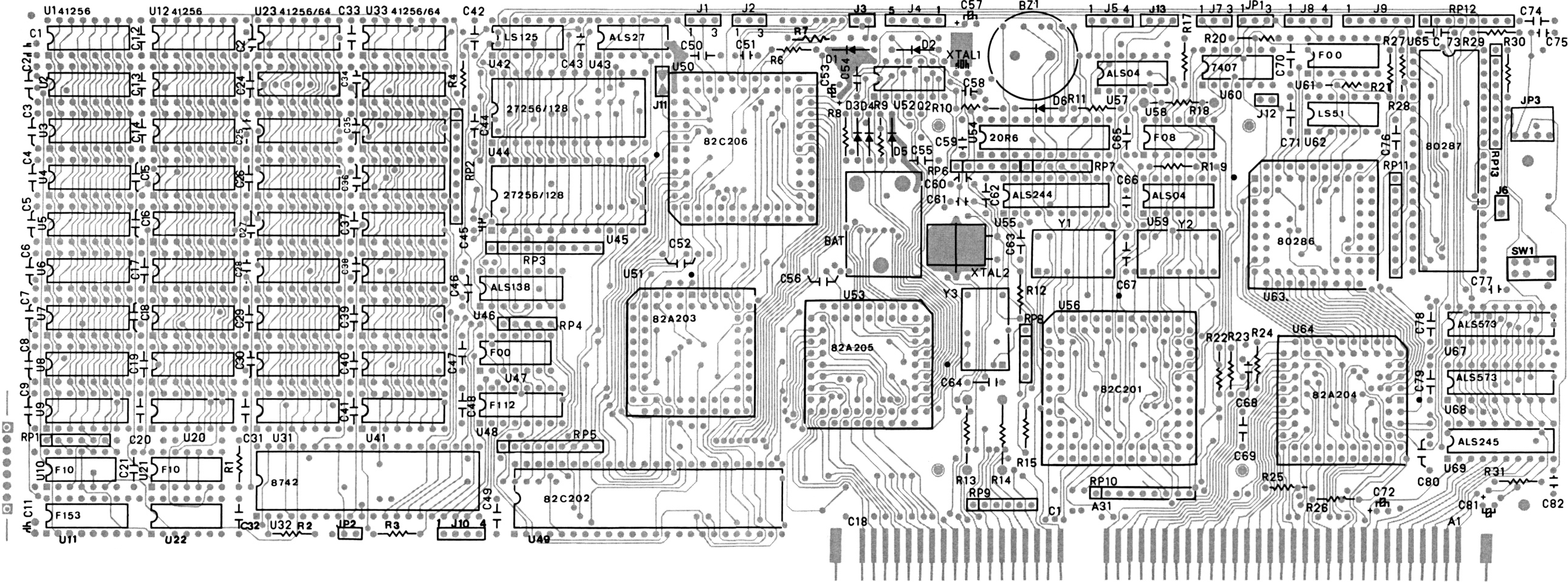

CPU Board

Soldering side

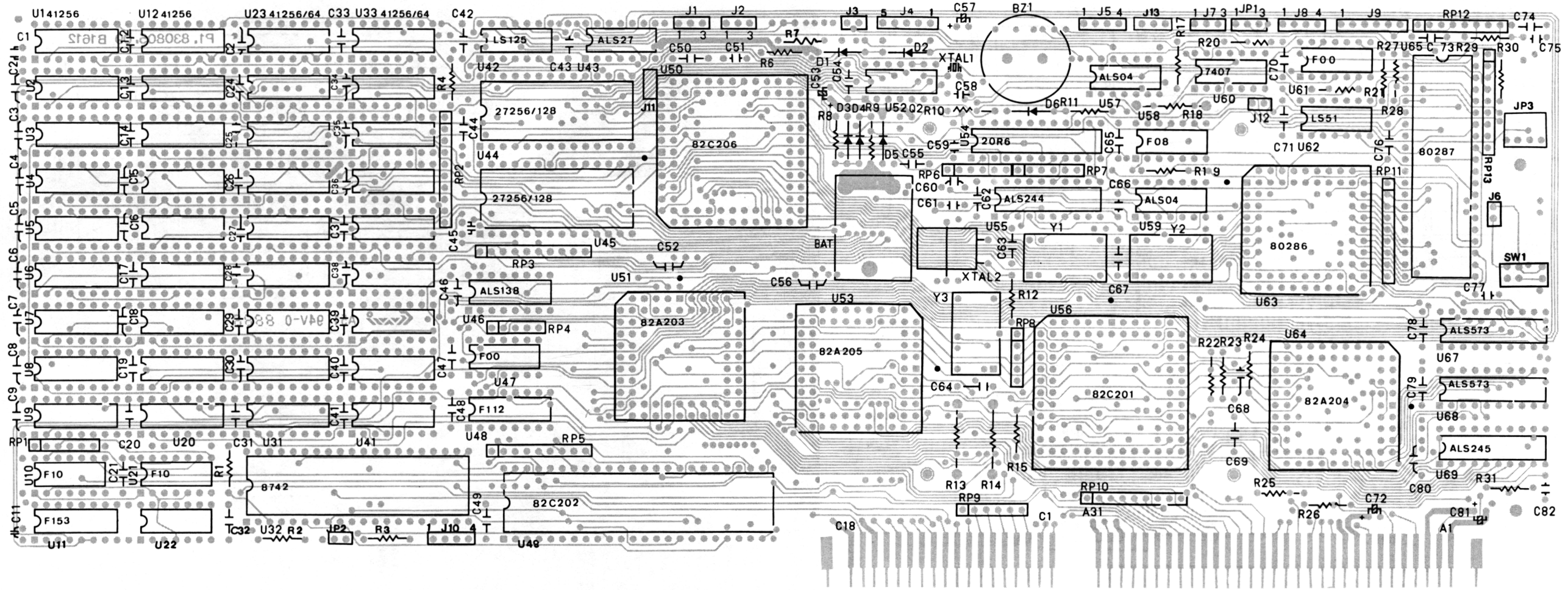

Schematic diagram

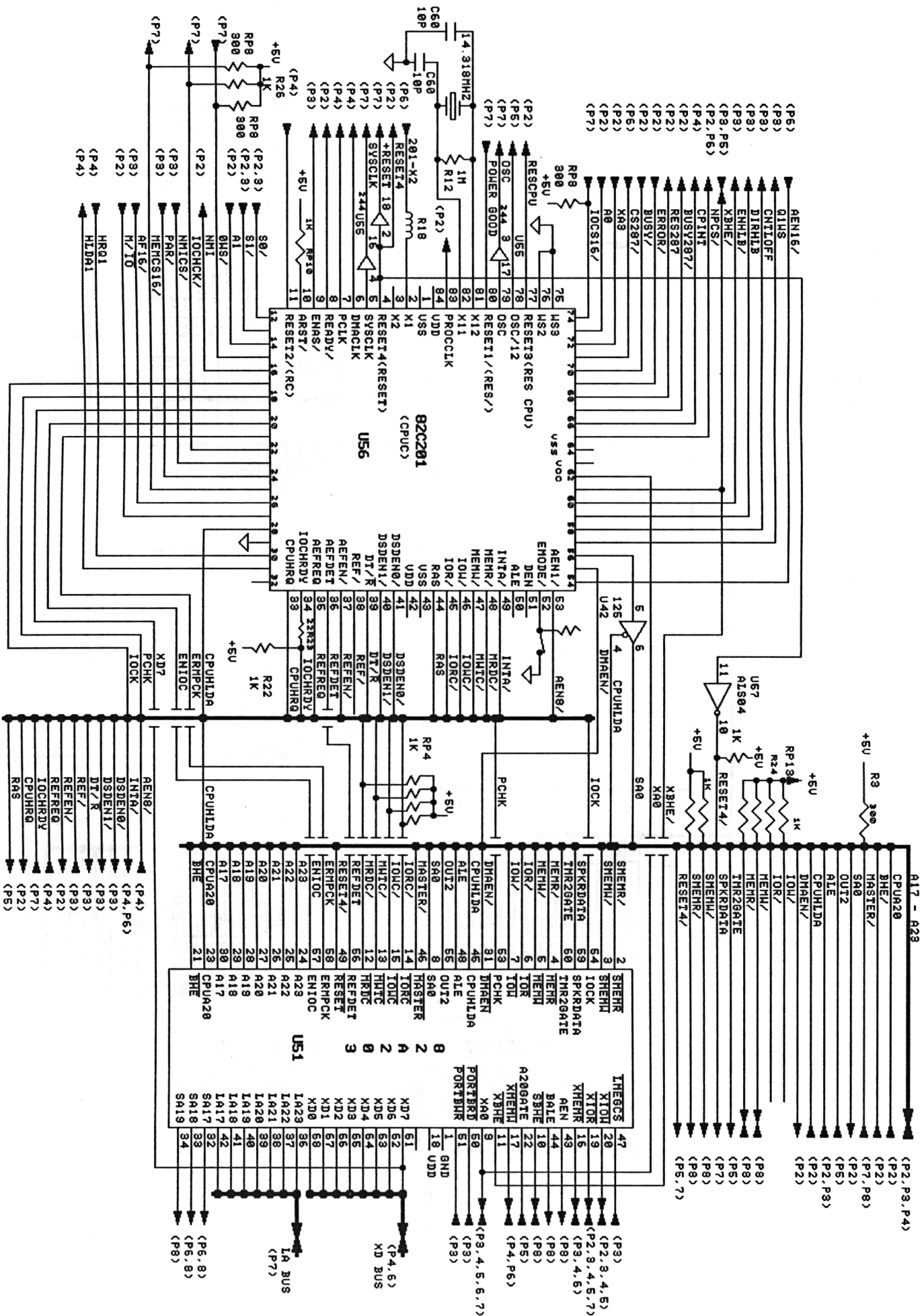

Schematic diagram

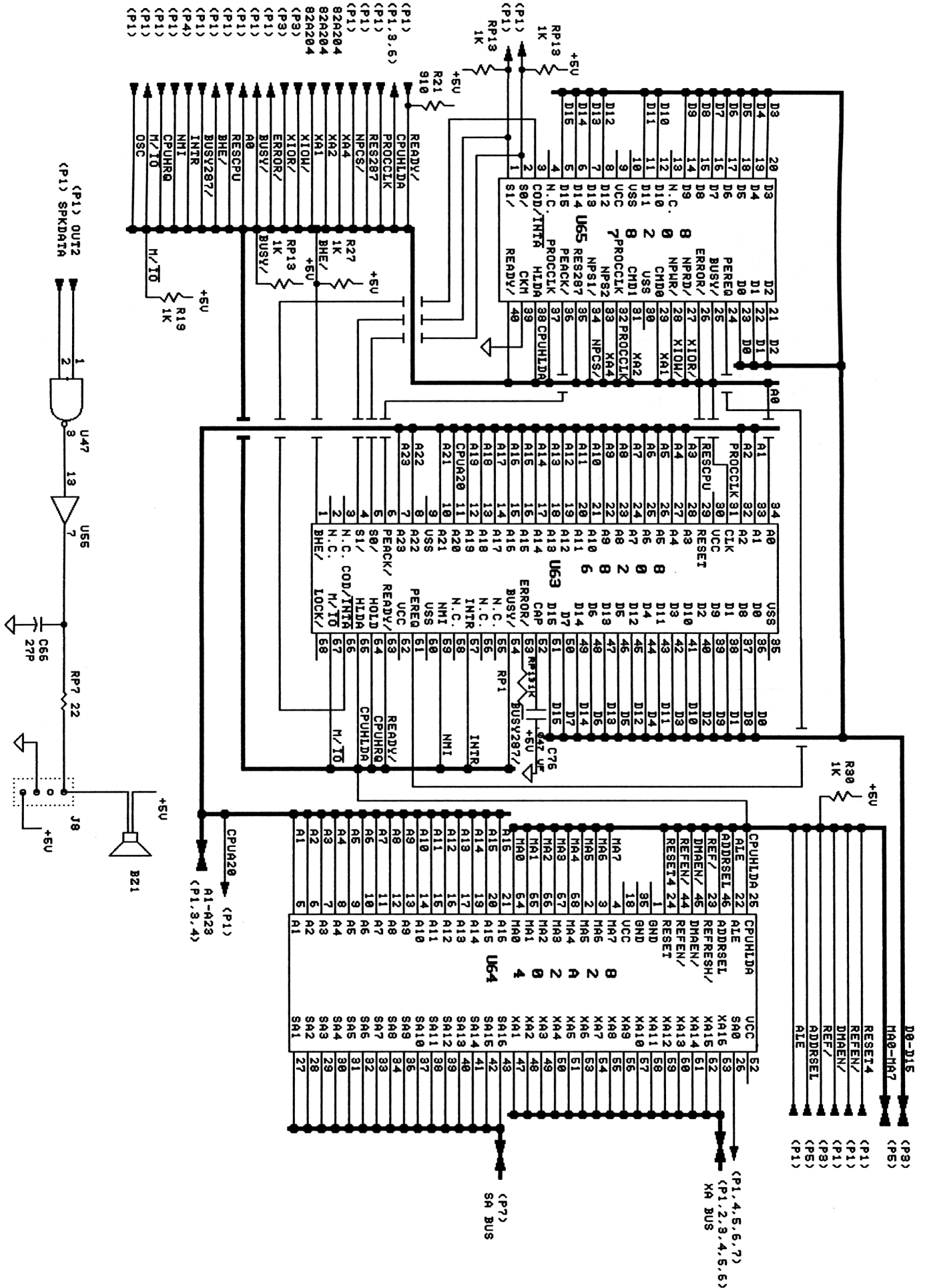

Schematic diagram

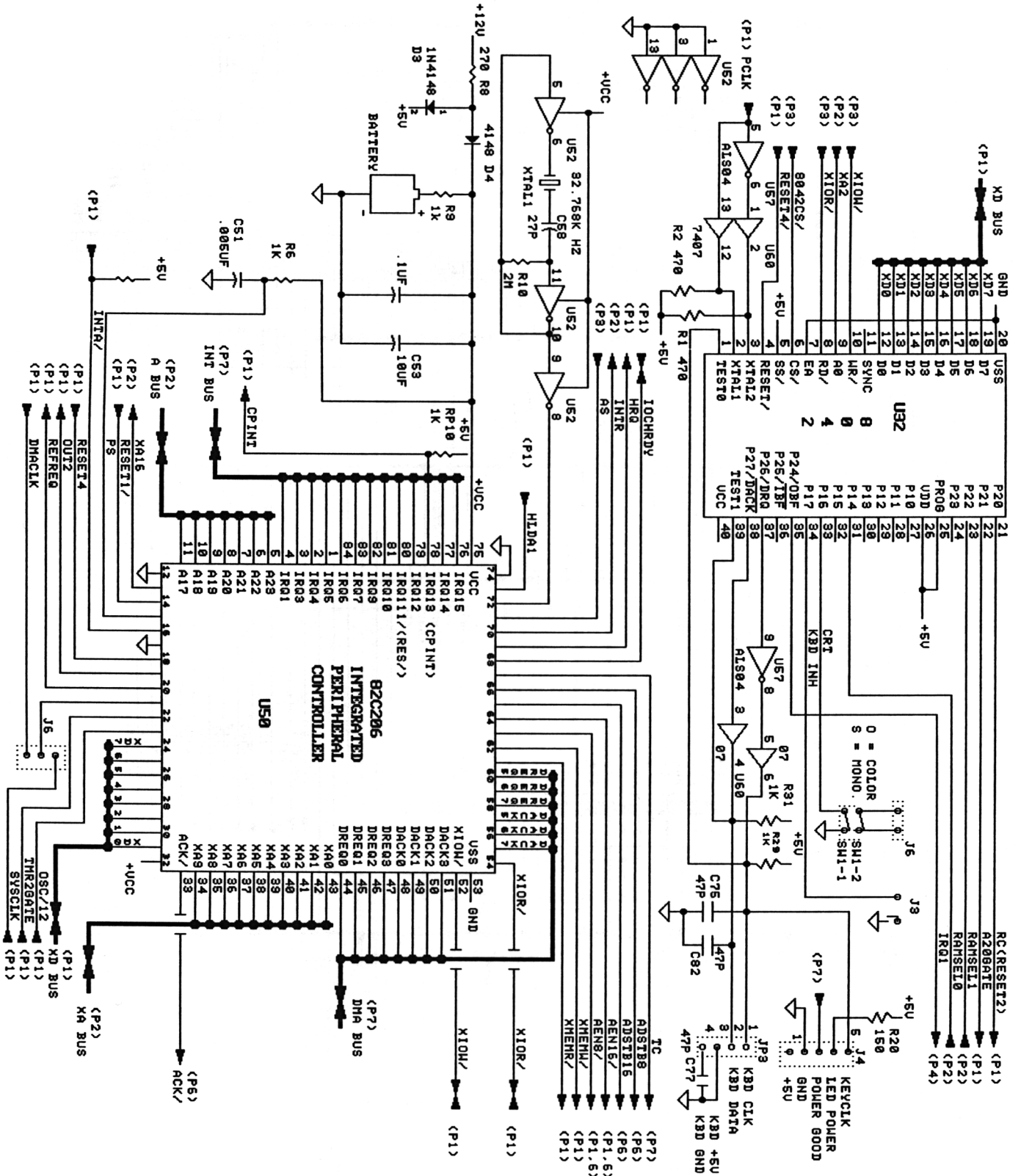

Schematic diagram

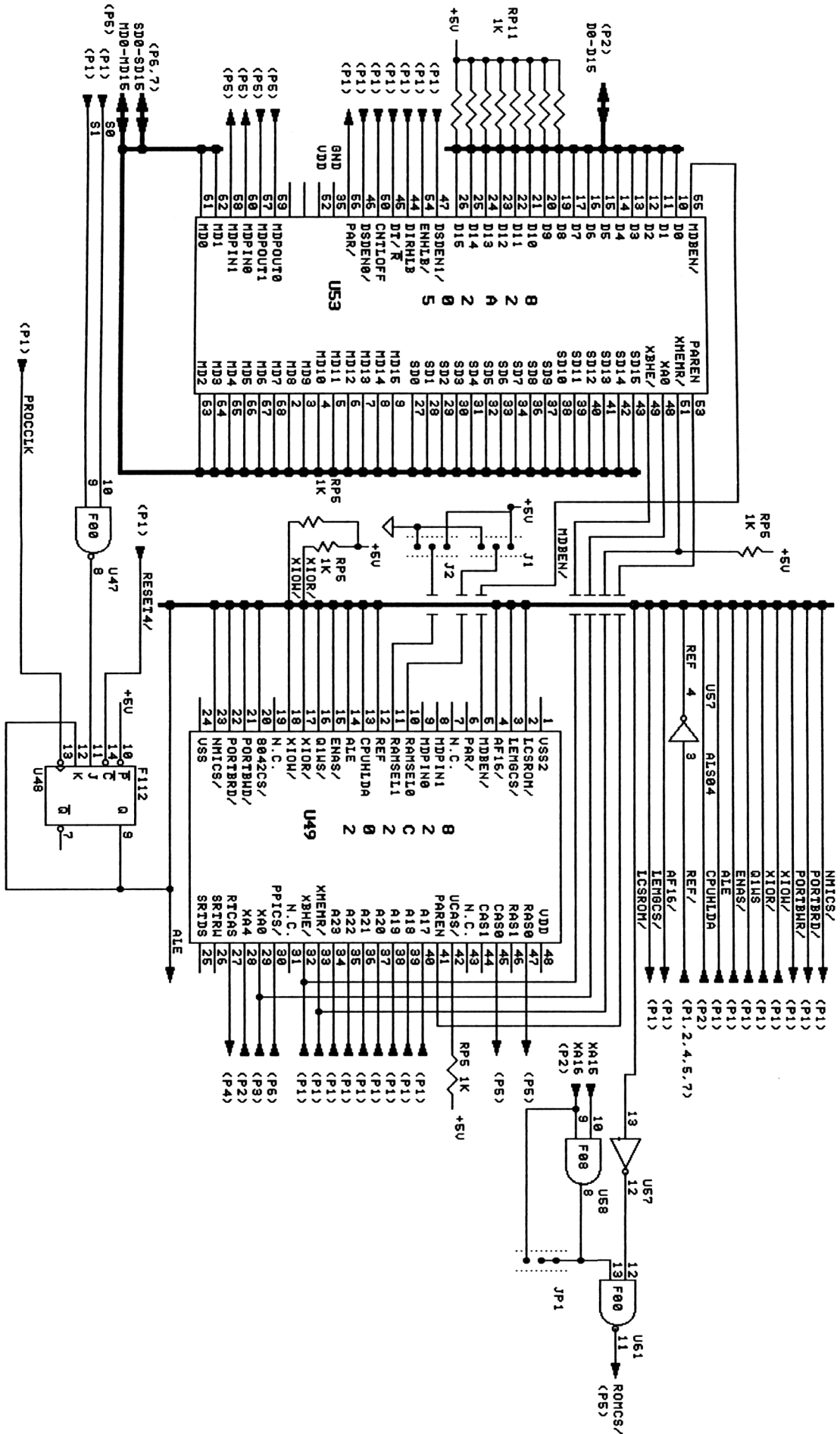

Schematic diagram

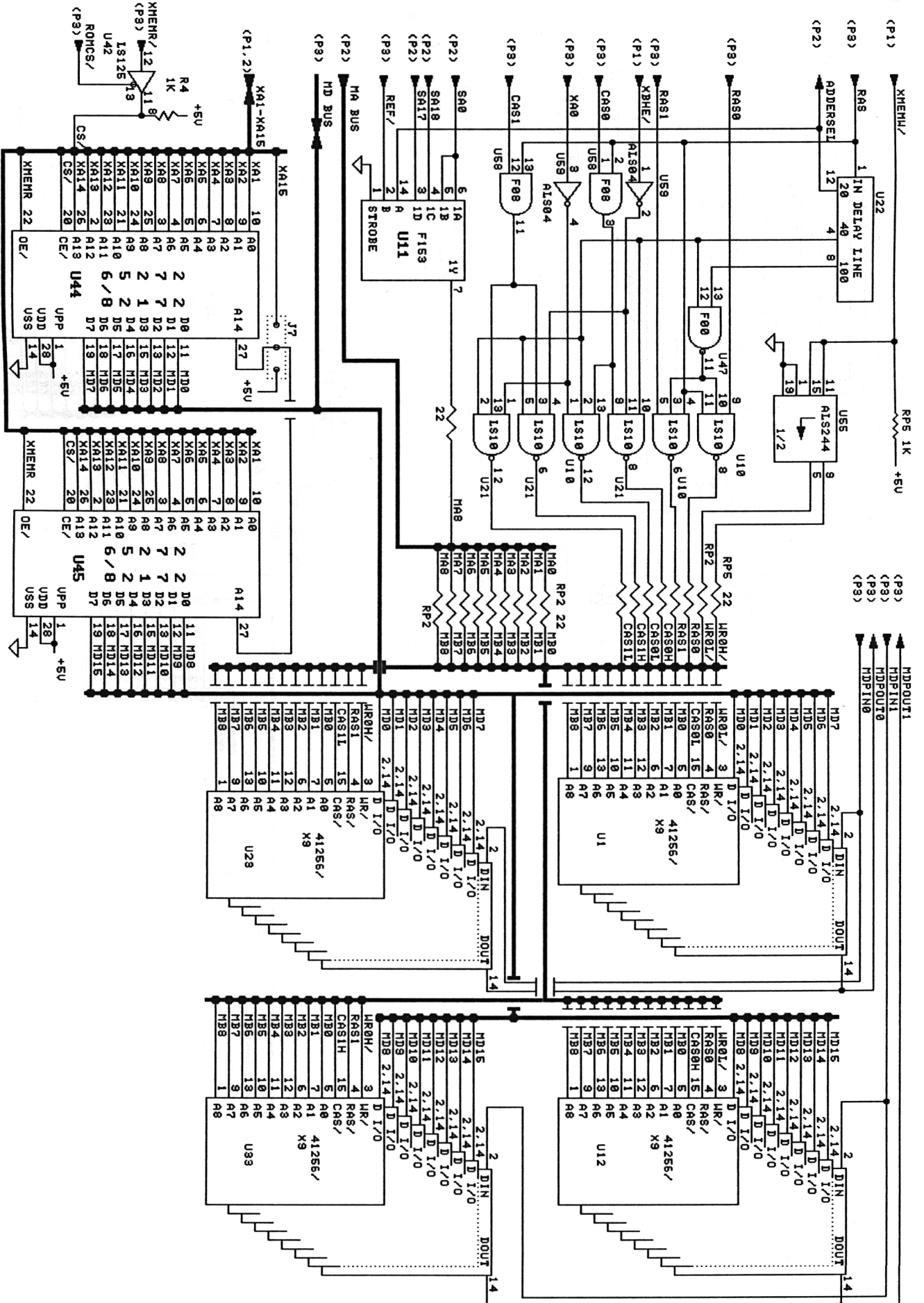

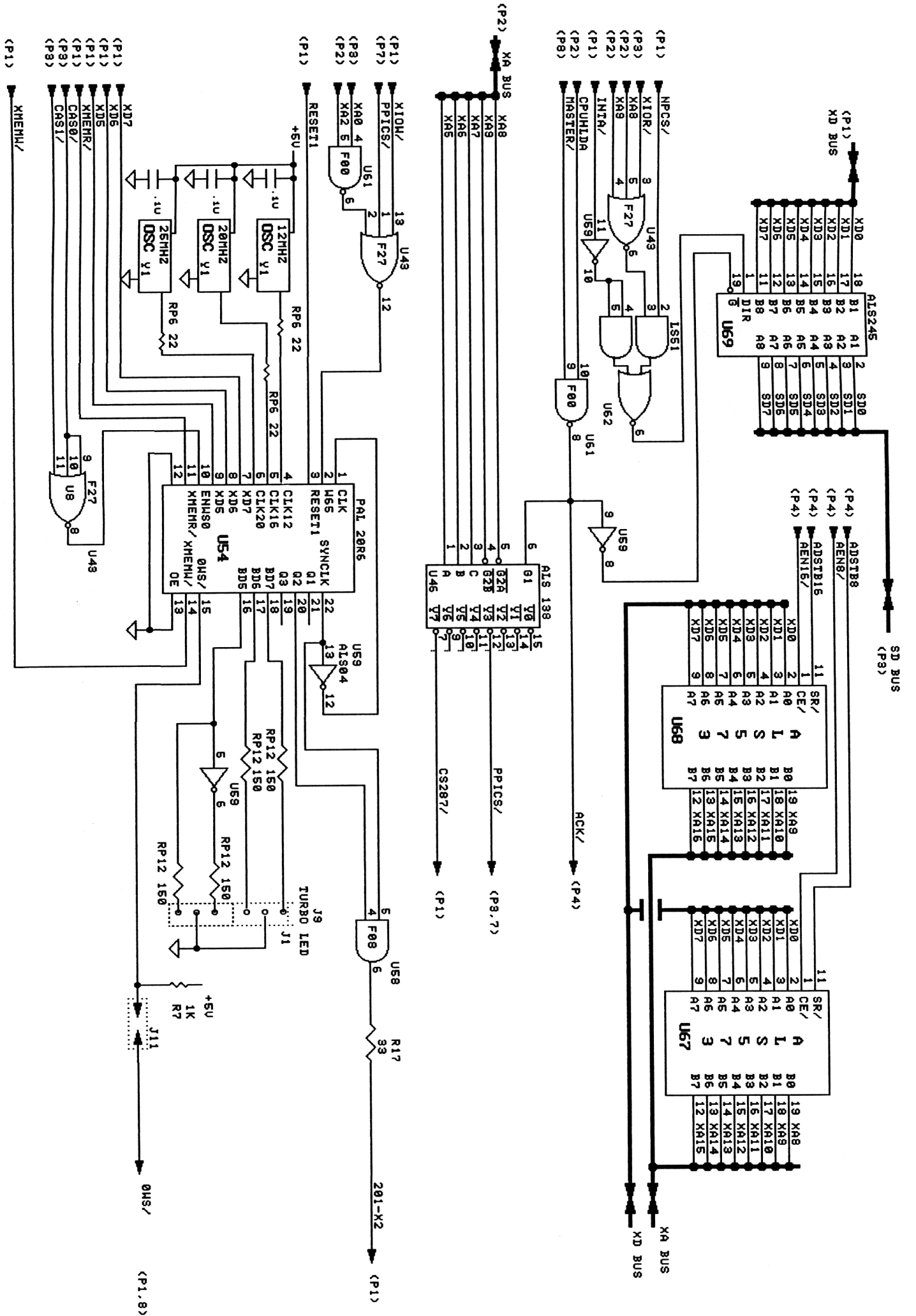

Schematic diagram

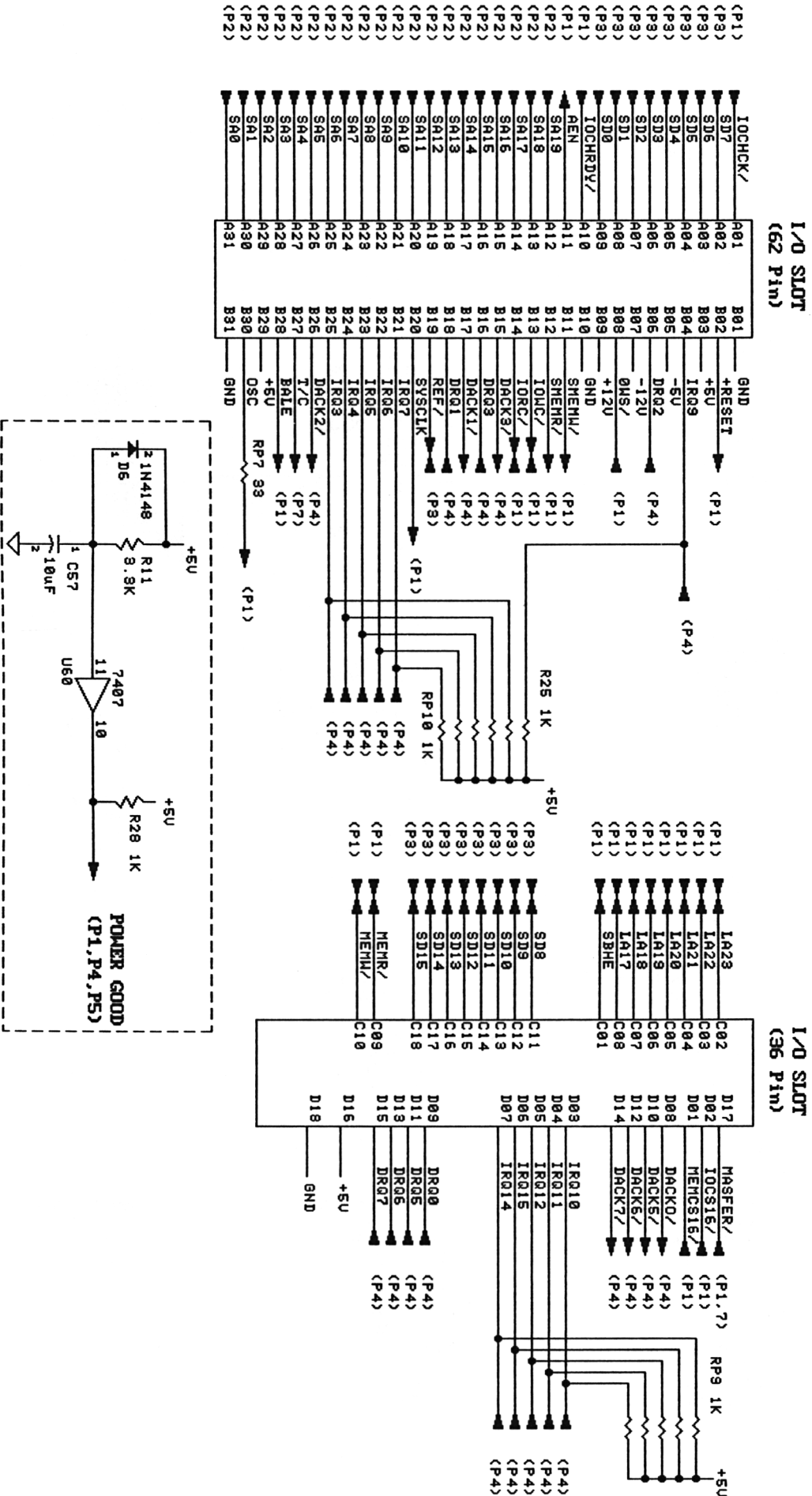

Ersatzteilliste für PC 2640 Multi I/O
Parts List for PC 2640 Multi I/O

Best.-Nr. Part.-No.	Bezeichnung	Description	Zeichen-Pos. Ref.-No.	Preisgruppe
40 937 00	Platine Multi I/O	Multi I/O Board	-	J 9
IC				
40 938 00	IC WD10C21A-PH	IC WD10C21A-PH	U 1	E 2
40 940 00	IC 74LS30	IC 74LS30	U 2	A 5
15 241 00	IC 7406	IC 7406	U 3	A 7
40 941 00	IC RAM 2016	IC RAM 2016	U 4	B 8
40 942 00	IC UM 8398	IC UM 8398	U 5	D 8
40 943 00	IC 2764	IC 2764	U 6	C 3
15 241 00	IC 7406	IC 7406	U 7, 8	A 7
29 231 00	IC 74LS74	IC 74LS74	U 9	B 1
40 944 00	IC WD1015C-PL	IC WD1015C-PL	U 10	E 2
40 955 00	IC WD5011-PL	IC WD5011-PL	U 11	E 2
40 956 00	IC 74LS173	IC 74LS173	U 12	A 7
40 957 00	IC WD11C00C JU	IC WD11C00C JU	U 13	E 2
32 167 00	IC 74LS14	IC 74LS14	U 14	A 6
29 224 00	IC 74LS08	IC 74LS08	U 15	A 9
40 958 00	IC 3487	IC 3487	U 16	B 2
15 241 00	IC 7406	IC 7406	U 17	A 7
40 959 00	IC 3486	IC 3486	U 18	B 2
40 960 00	IC 4464-12 RAM	IC 4464-12 RAM	U 19-22	C 8
40 961 00	IC 74LS123	IC 74LS123	U 23	A 5
34 767 00	IC 74LS125	IC 74LS125	U 24	A 7
40 961 00	IC 74LS123	IC 74LS123	U 25	A 5
40 963 00	IC 74F245	IC 74F245	U 26	A 7
32 172 00	IC 74LS139	IC 74LS139	U 27	A 6
40 964 00	IC 74S32	IC 74S32	U 28	A 5
26 347 00	IC 74LS153	IC 74LS153	U 29	B 2
40 965 00	IC 4464-12 RAM	IC 4464-12 RAM	U 30-33	C 8
29 294 00	IC 74LS04	IC 74LS04	U 34	A 9
26 121 00	IC 74LS00	IC 74LS00	U 35	A 5
40 966 00	IC 75154	IC 75154	U 36, 37	B 2
34 768 00	IC 74LS174	IC 74LS174	U 38	A 7
26 354 00	IC 74LS244	IC 74LS244	U 39	B 0
40 087 00	IC PEGA1A	IC PEGA1A	U 40	F 4
40 967 00	IC 75150	IC 75150	U 41-44	B 1
40 117 00	IC 74LS20	IC 74LS20	U 45	A 5
40 968 00	IC 75154	IC 75154	U 46	B 2
40 969 00	IC ROM27128-15	IC ROM27128-15	U 47	D 0
40 970 00	IC PAL 20L8ANC	IC PAL 20L8ANC	U 48	C 5
26 354 00	IC 74LS244	IC 74LS244	U 49	B 9
40 971 00	IC PAL 20L8ANC	IC PAL 20L8ANC	U 50	C 5
40 972 00	IC 83747	IC 83747	U 51	E 3
40 973 00	IC 74F20	IC 74F20	U 52	A 5
40 974 00	IC 74LS28	IC 74LS28	U 53	A 5
40 975 00	IC 2015.15 RAM	IC 2015.15 RAM	U 54	B 5
40 976 00	IC PAL 16L8ANC	IC PAL 16L8ANC	U 55	B 7
34 772 00	IC 74LS245	IC 74LS245	U 56	B 0
40 977 00	IC 74LS257	IC 74LS257	U 57	A 5
32 095 00	IC 74LS138	IC 74LS138	U 58	A 6
40 978 00	IC 74LS374	IC 74LS374	U 59	A 8
34 772 00	IC 74LS245	IC 74LS245	U 60	B 0
40 940 00	IC 74LS30	IC 74LS30	U 61	A 5
Verschiedenes/Miscellaneous				
40 994 00	Widerstand/Netzwerk	Resistor, Network	RN 1, 4, 5, 10	A 3
40 995 00	Widerstand/Netzwerk	Resistor, Network	RN 2, 3	A 3
40 996 00	Widerstand/Netzwerk	Resistor, Network	RN 6-9	A 3
44 003 00	Oszillator 24 MHz	Osc. 24 MHz	OS 1	B 5
44 004 00	Oszillator 1,8432 MHz	Osc. 1.8432 MHz	OS 2	B 5
44 005 00	Oszillator 16,257 MHz	Osc. 16.257 MHz	OS 3	B 5
44 006 00	Quarz 15 MHz	X Tal 15 MHz	X 1	B 5
44 007 00	Quarz 10 MHz	X Tal 10 MHz	X 2	B 5
44 012 00	Verzögerungsleitung	Delay line	Delay	B 9
34 805 00	Buchse 25pol.	Socket 25-pol.	-	C 0
34 806 00	Buchse 9pol.	Socket 9-pol.	-	B 7
44 027 00	DIP-SW 6fach	DIP-SW 6 Pos.	SW 1	B 2

Multi I/O Board

Component side

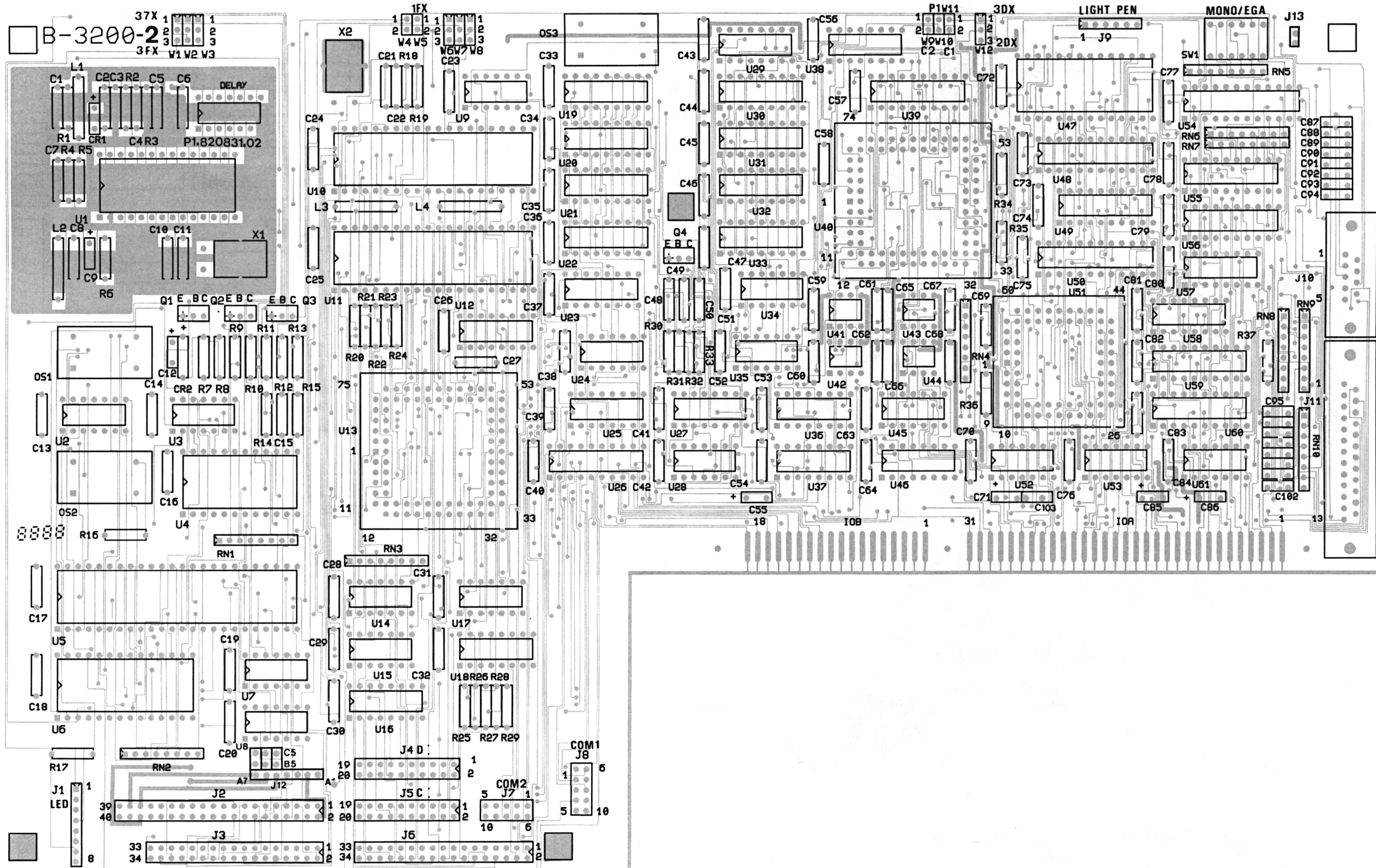

Multi I/O Board

Soldering side

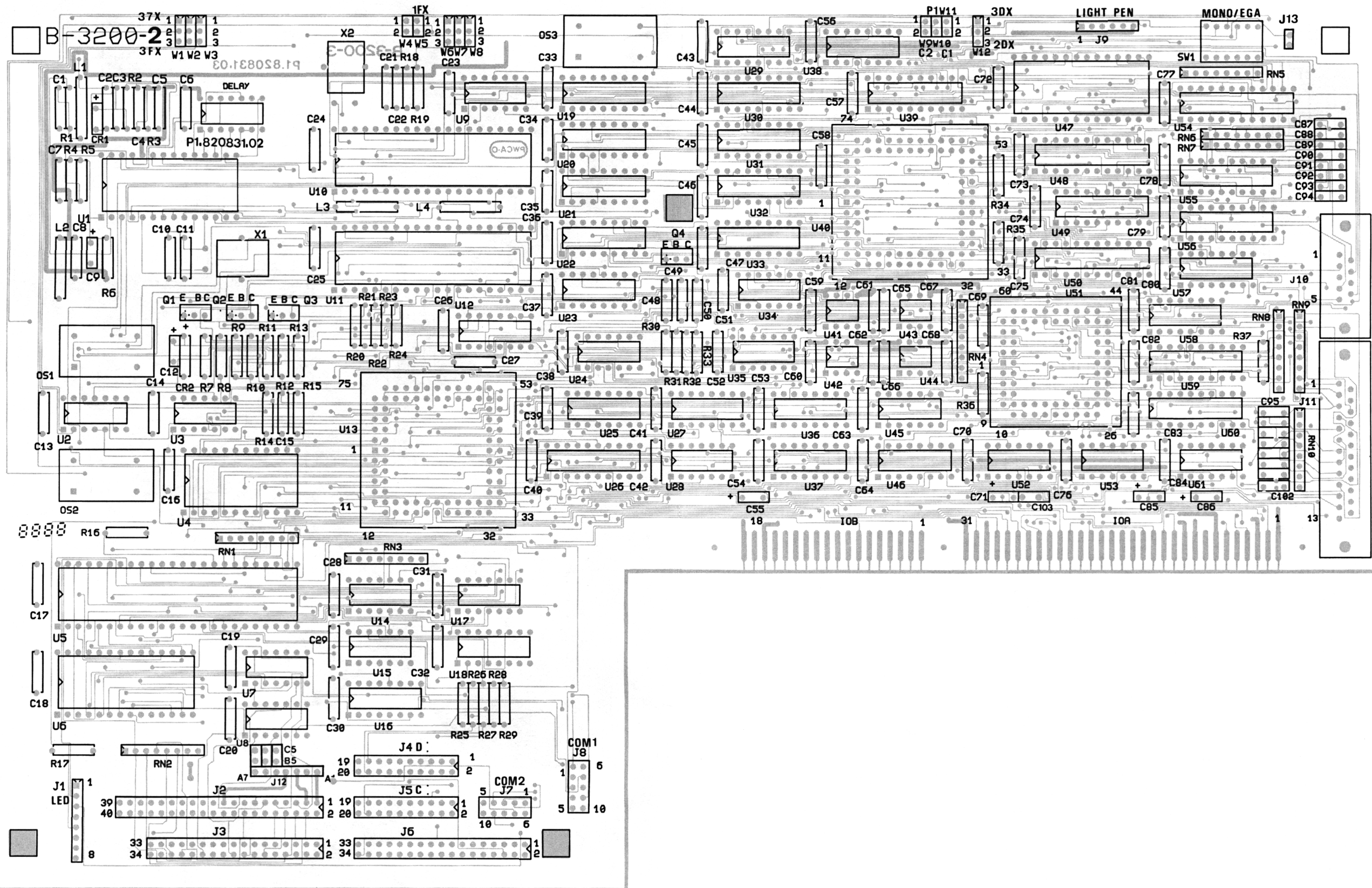

Block diagram

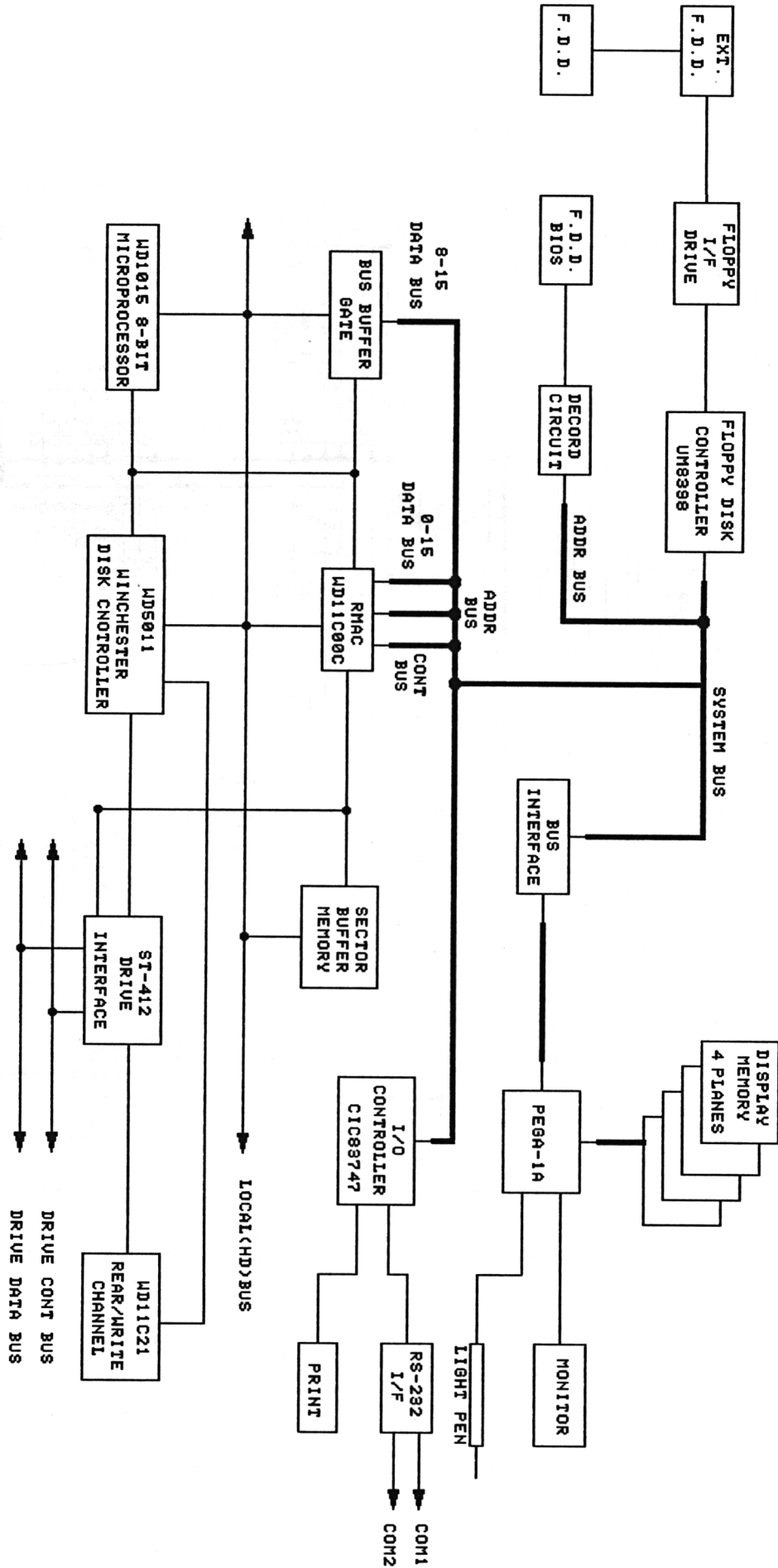

Multi I/O Board

Schematic diagram

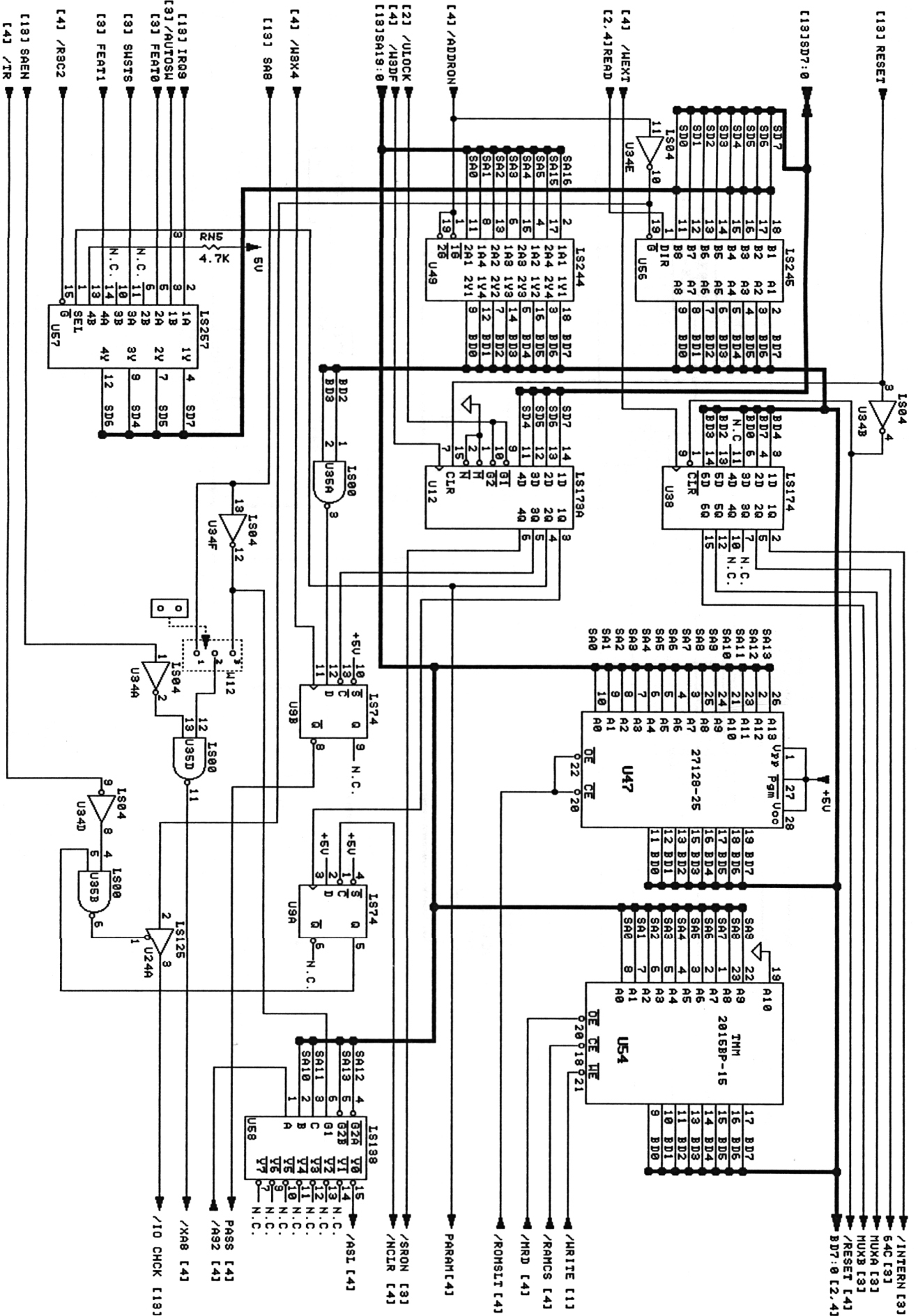

Schematic diagram

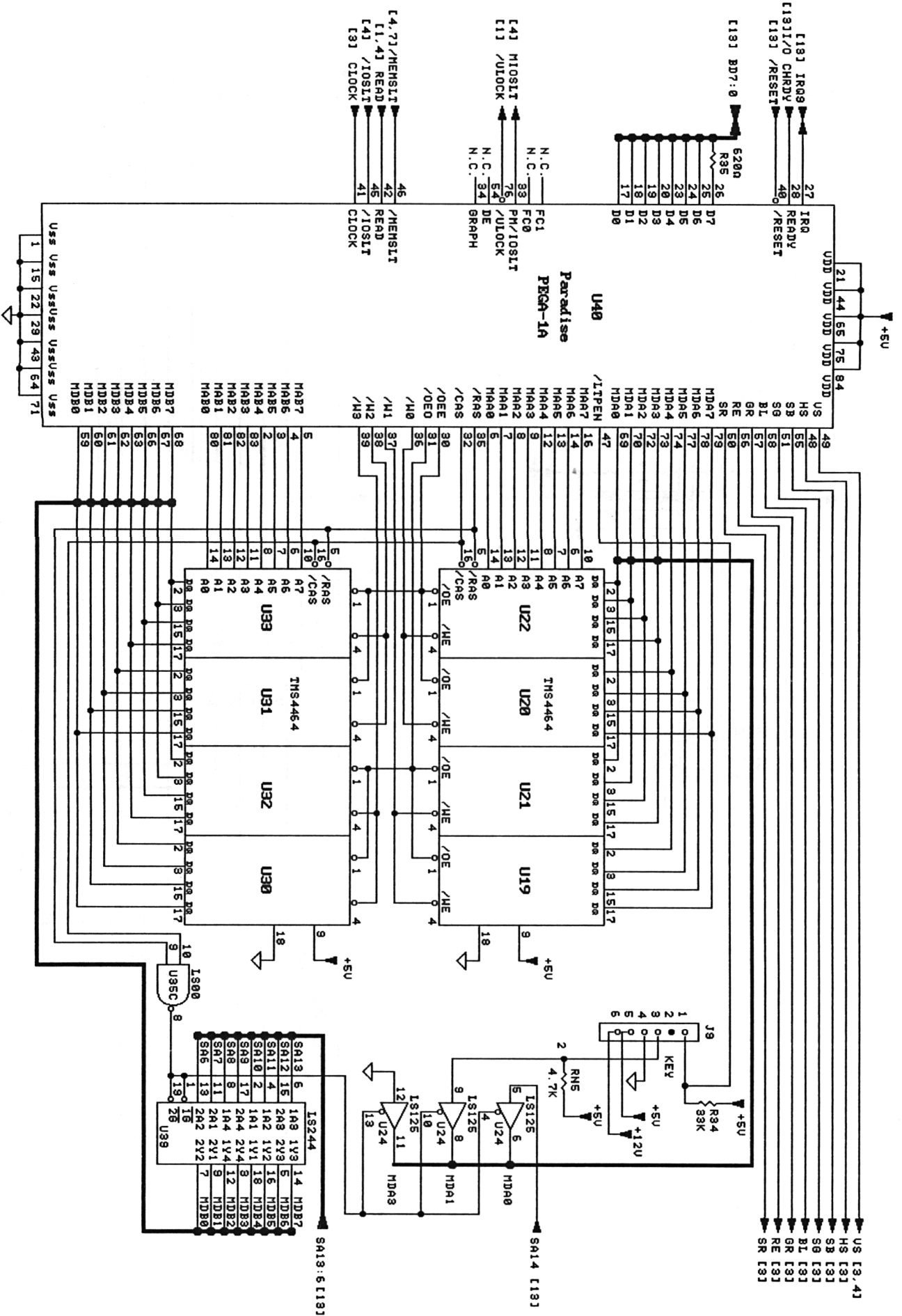

Schematic diagram

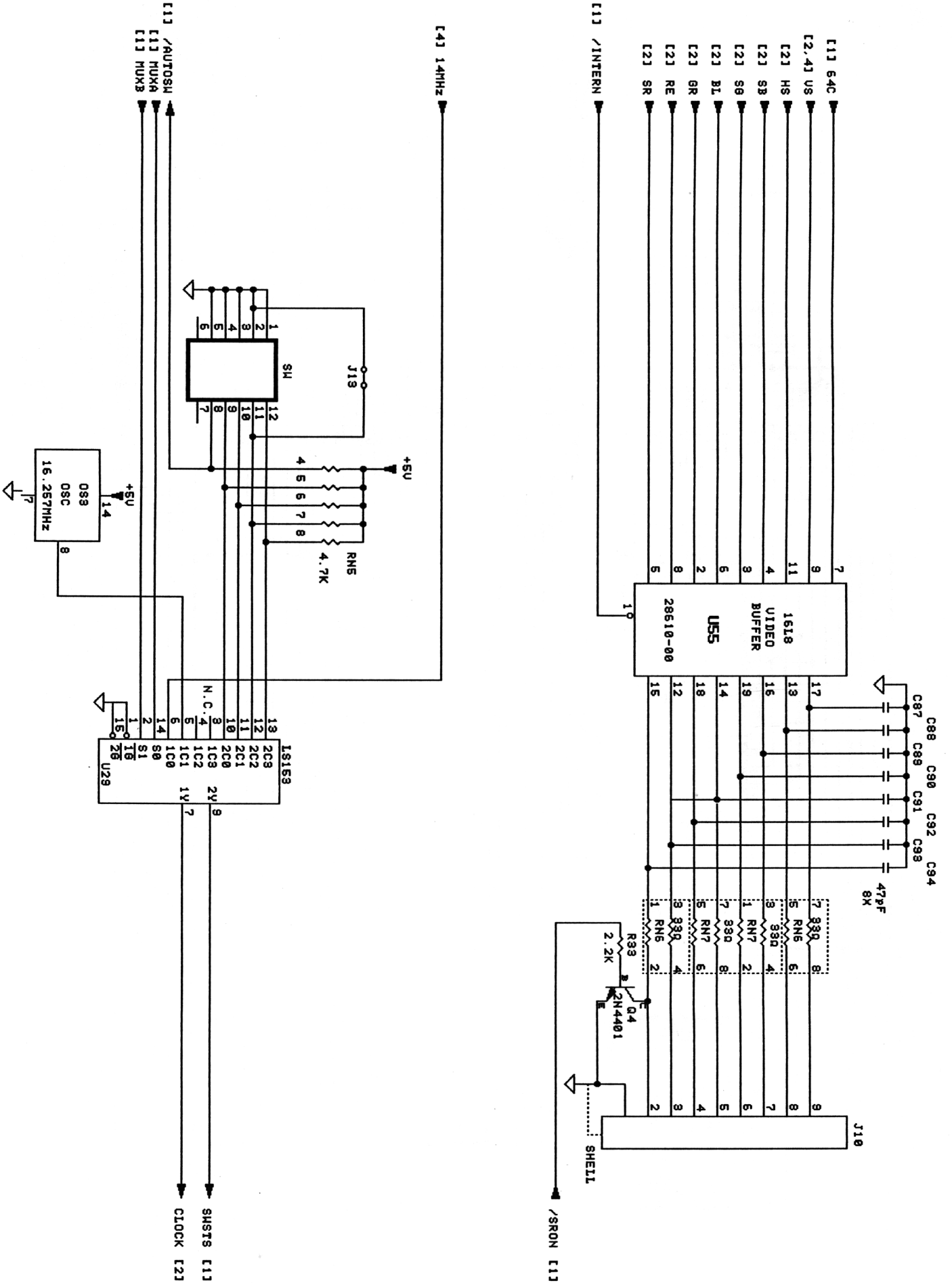

Schematic diagram

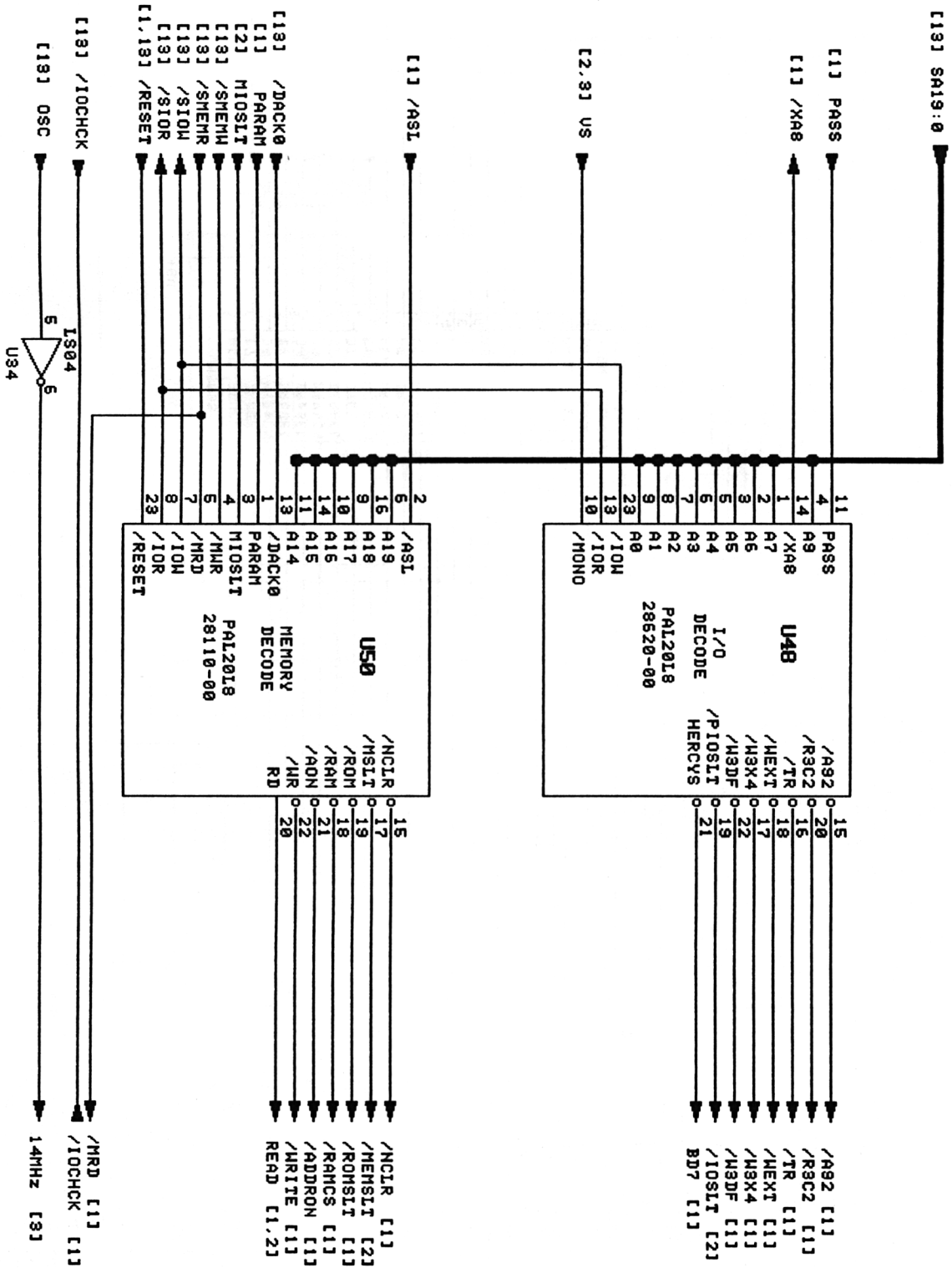

Schematic diagram

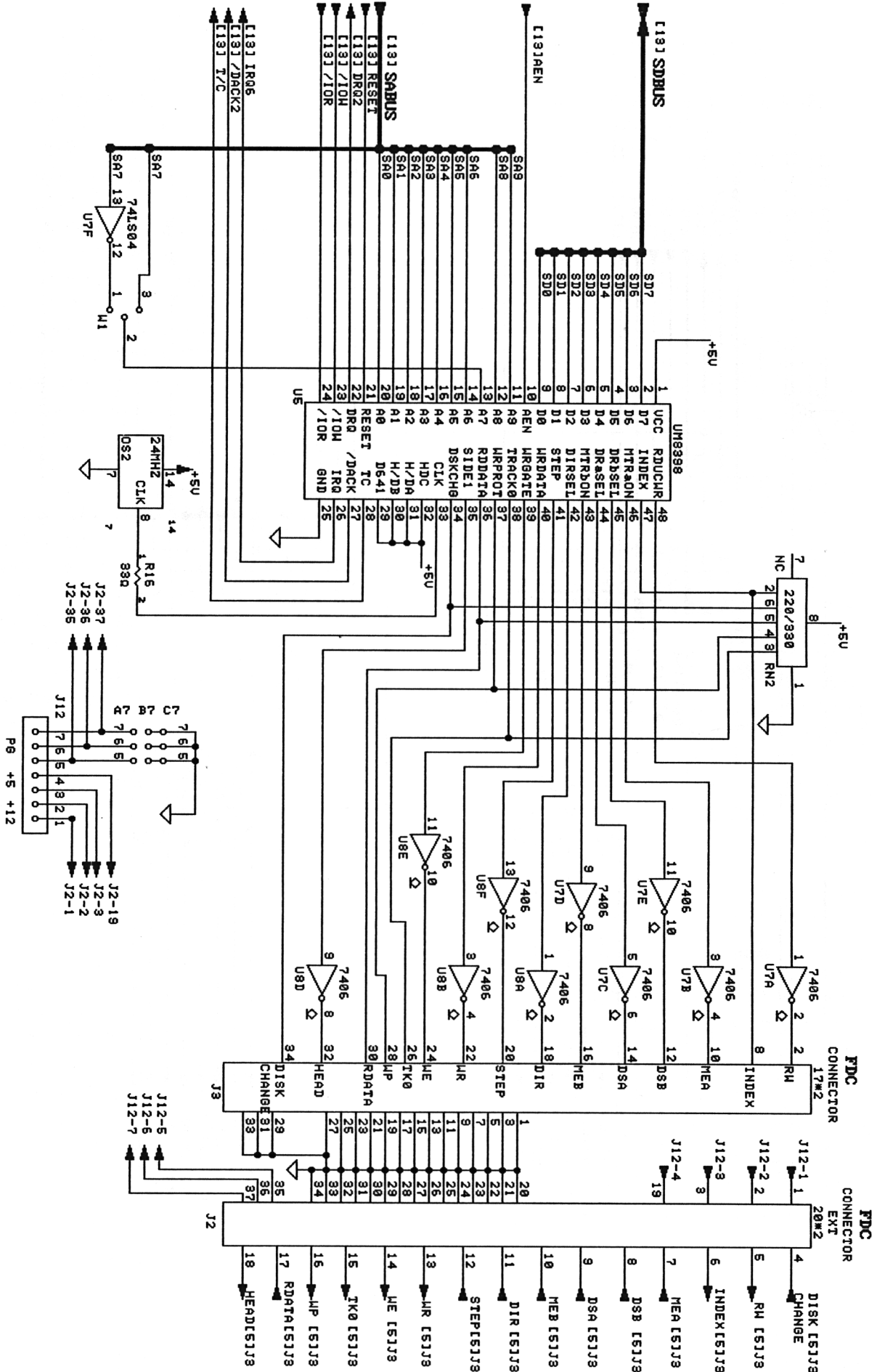

Schematic diagram

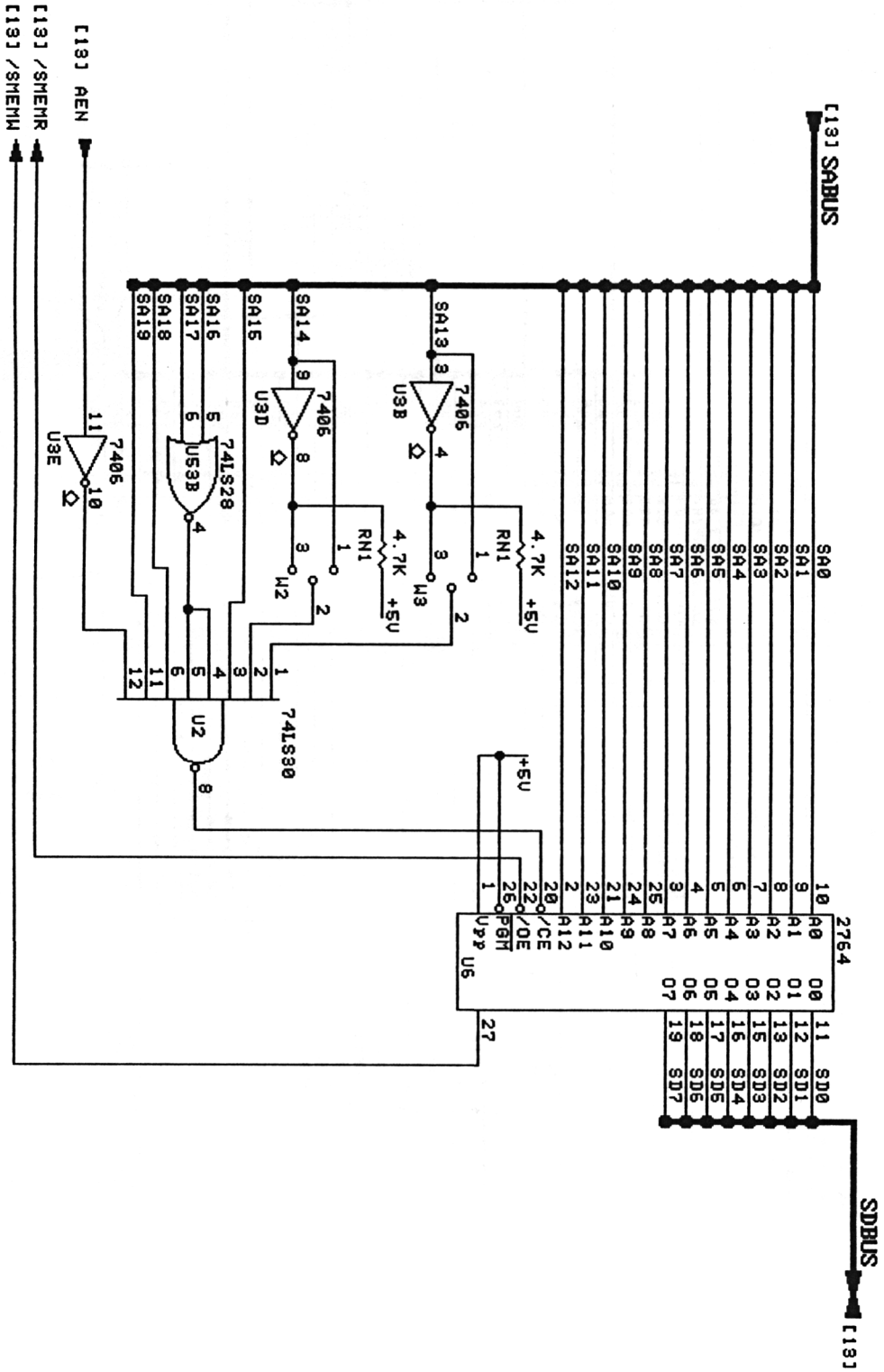

Multi I/O Board

Schematic diagram

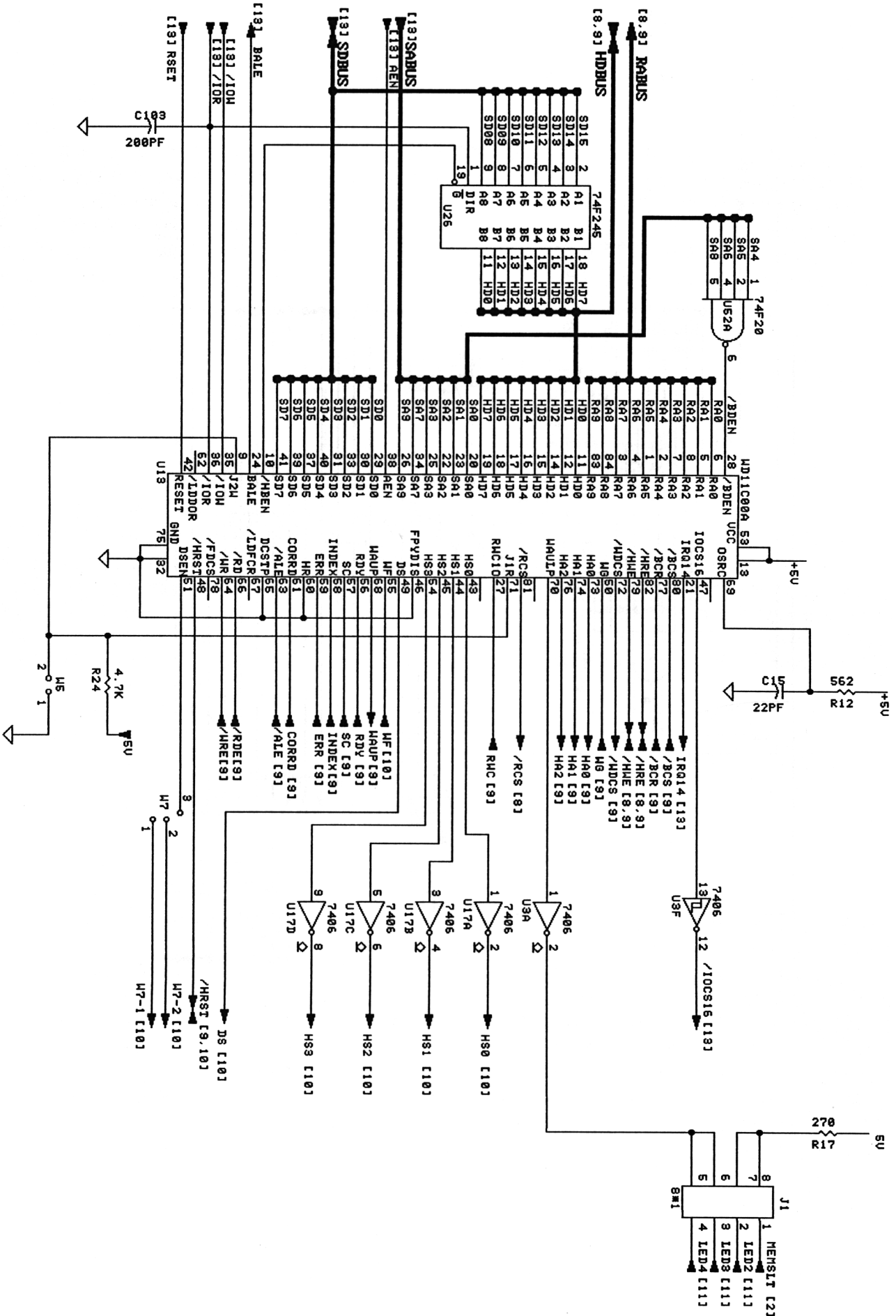

Schematic diagram

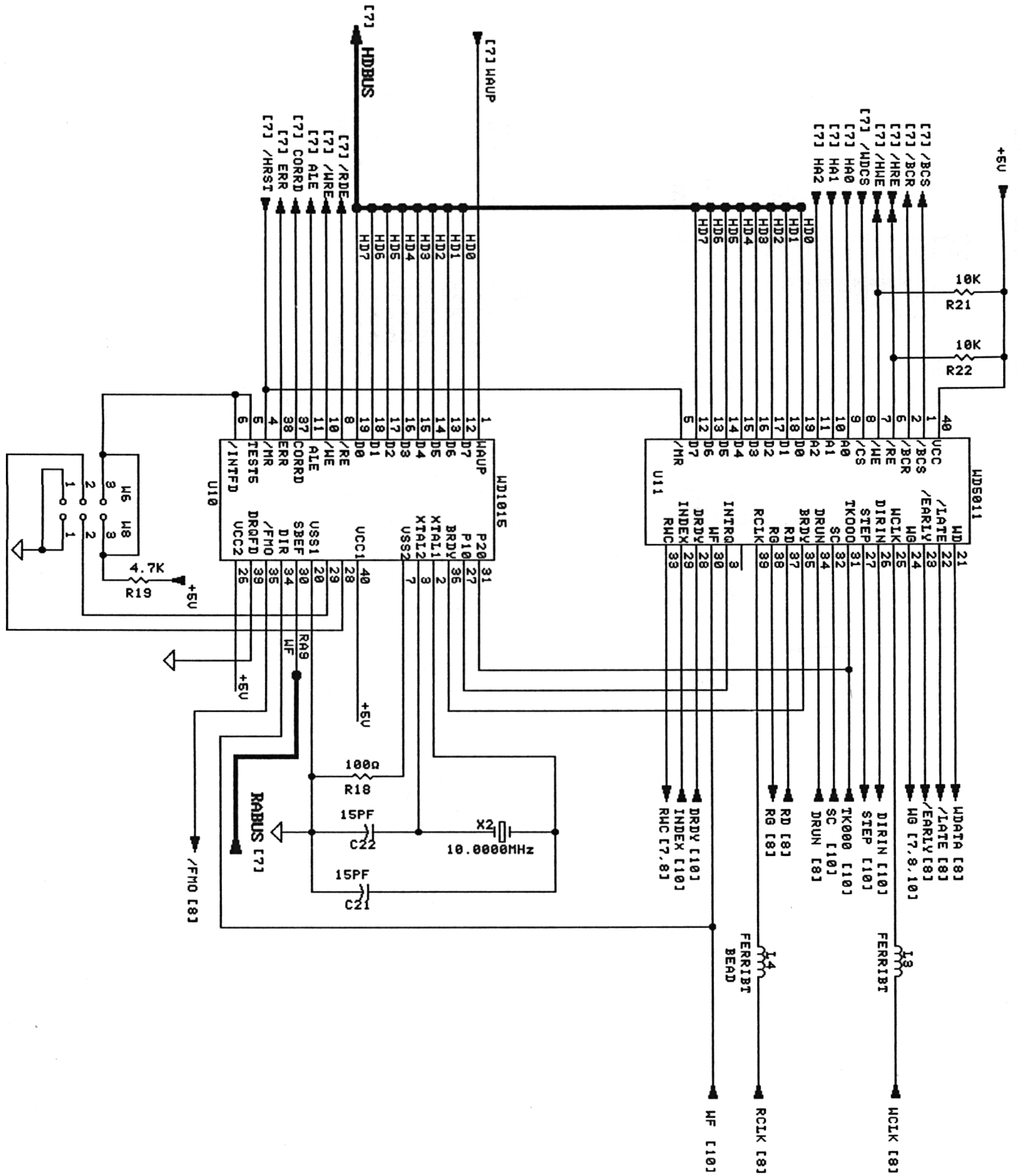

Schematic diagram

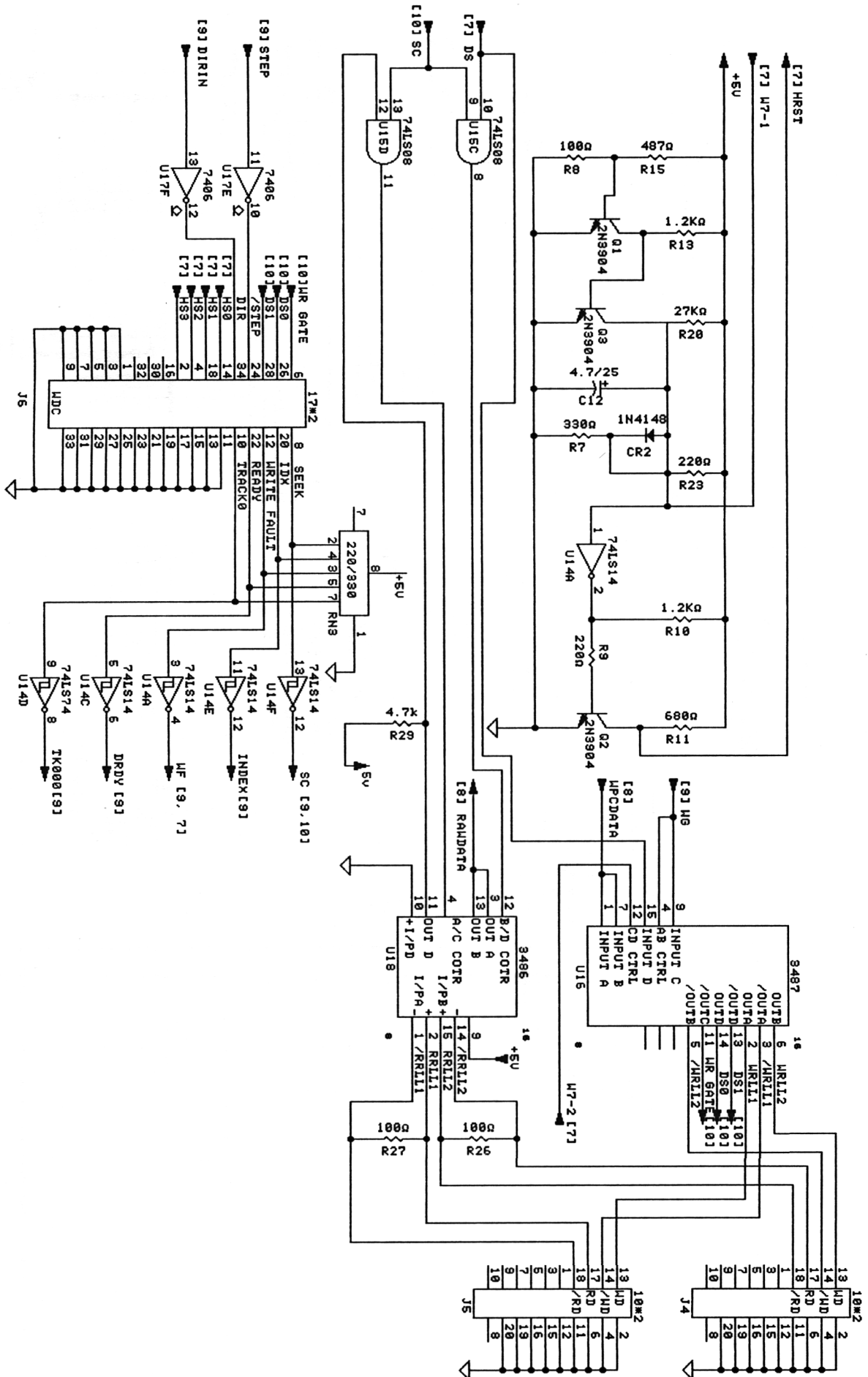

Schematic diagram

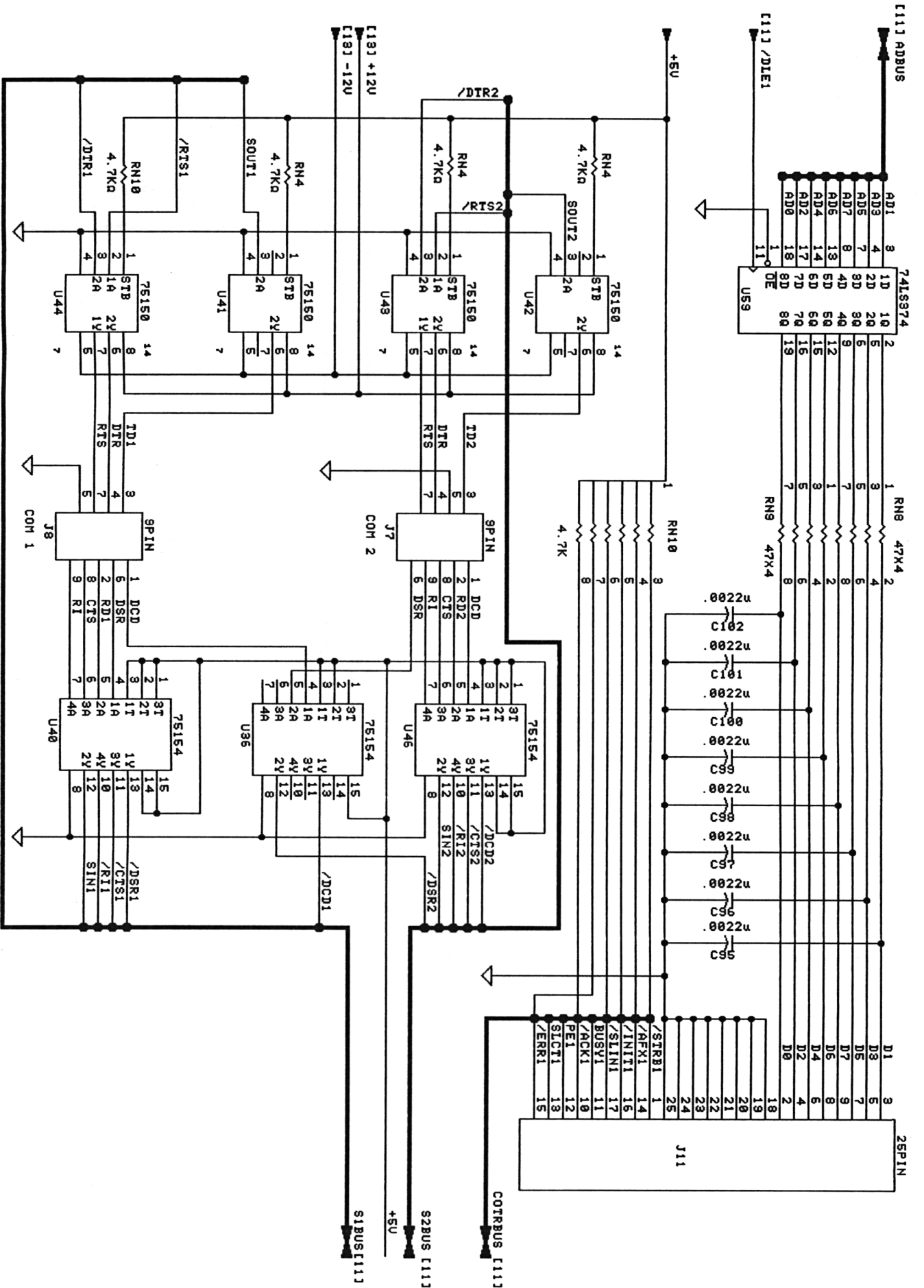

Multi I/O Board

Schematic diagram

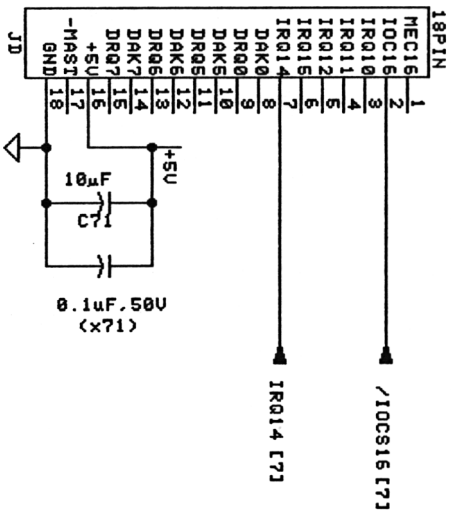
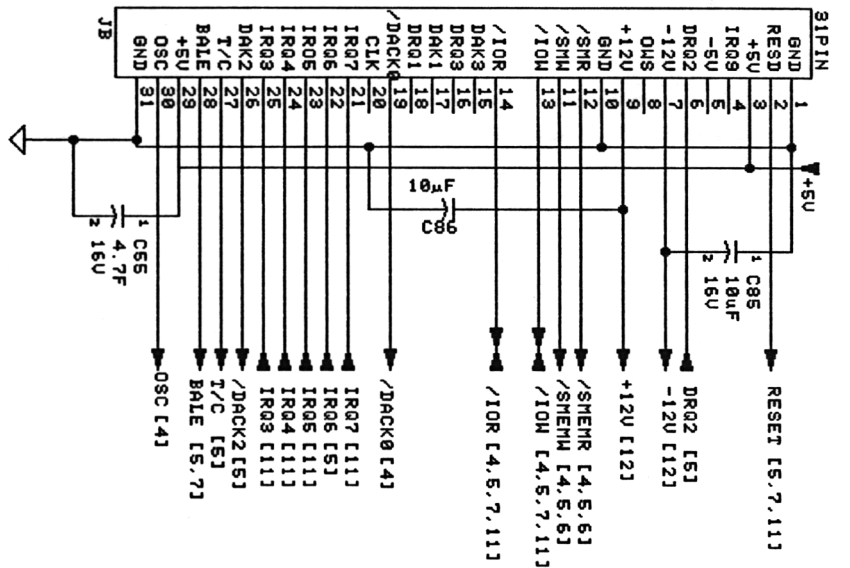
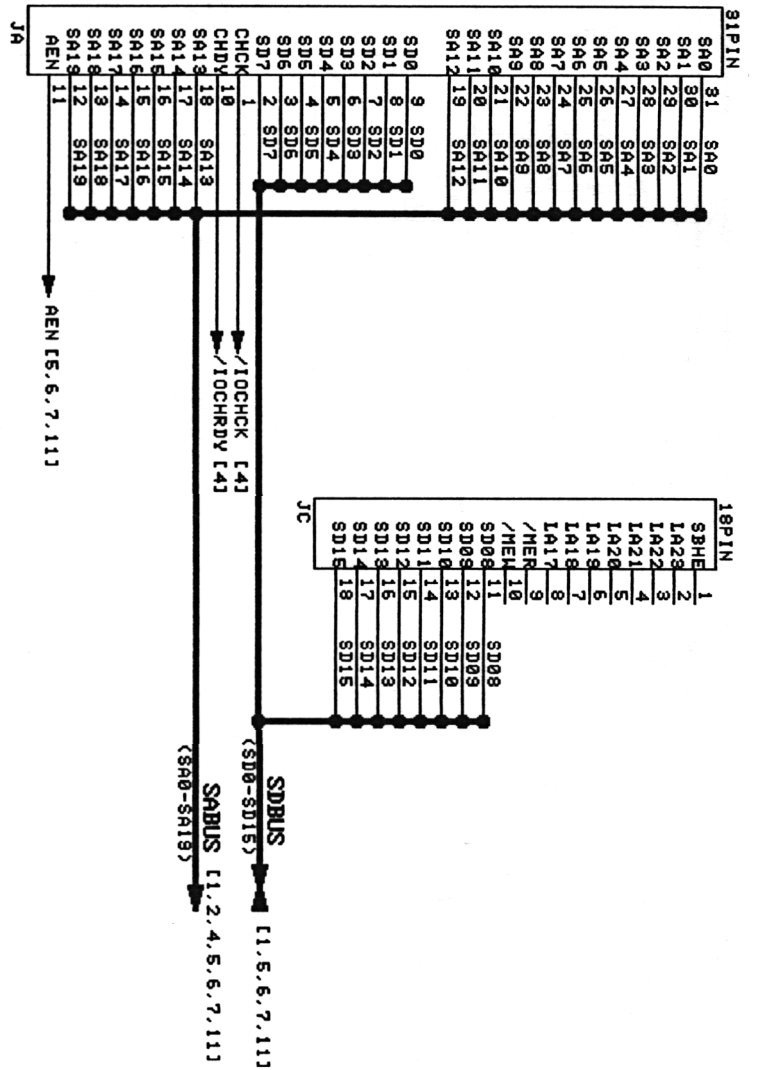

Ersatzteilliste für PC 2640
Parts List for PC 2640

Best.-Nr. Part.-No.	Bezeichnung	Description	Zeichen-Pos. Ref.-No.	Preisgruppe
Verschiedenes/Miscellaneous				
40 929 00	Platine Slot	Slot board	-	E 5
40 982 00	Netzteil	Power supply	-	G 4
40 931 00	HDD	HDD	-	J 9
40 962 00	FDD 3½"	FDD 3½"	-	H 1

Slot Board

Component side

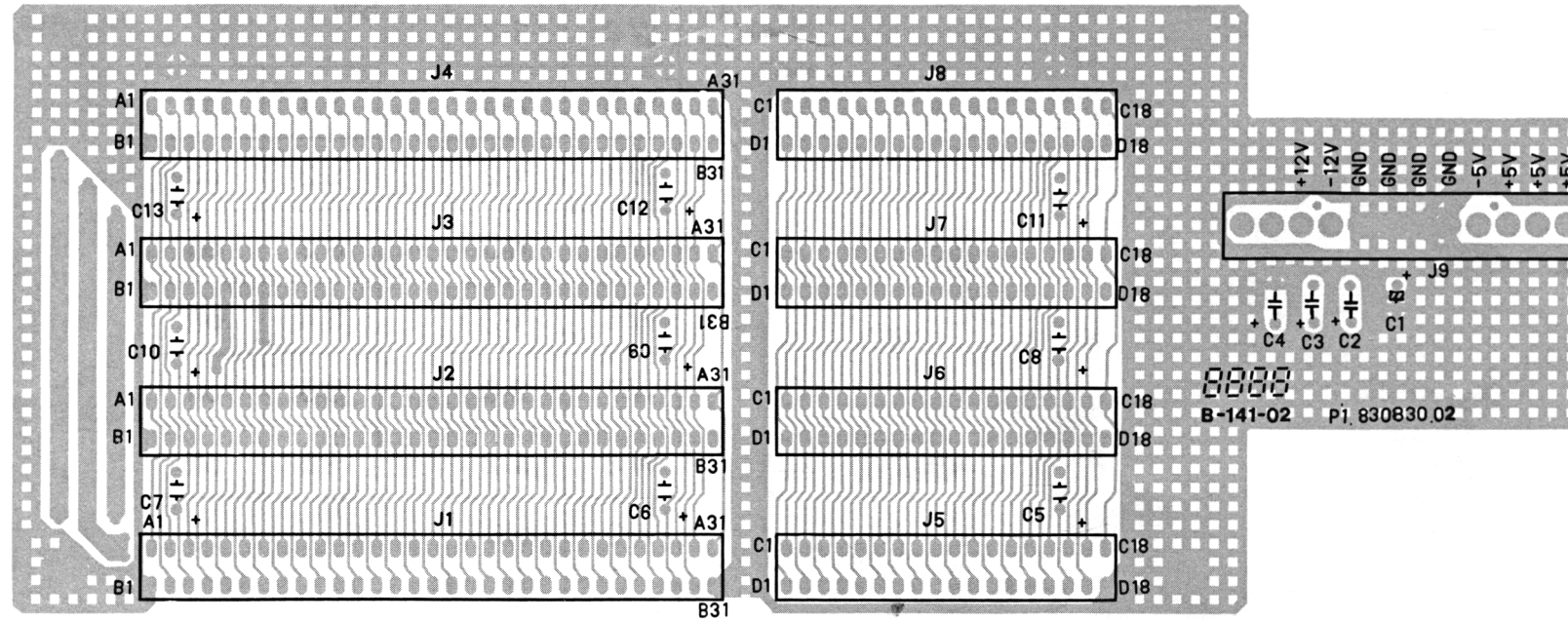

Soldering side

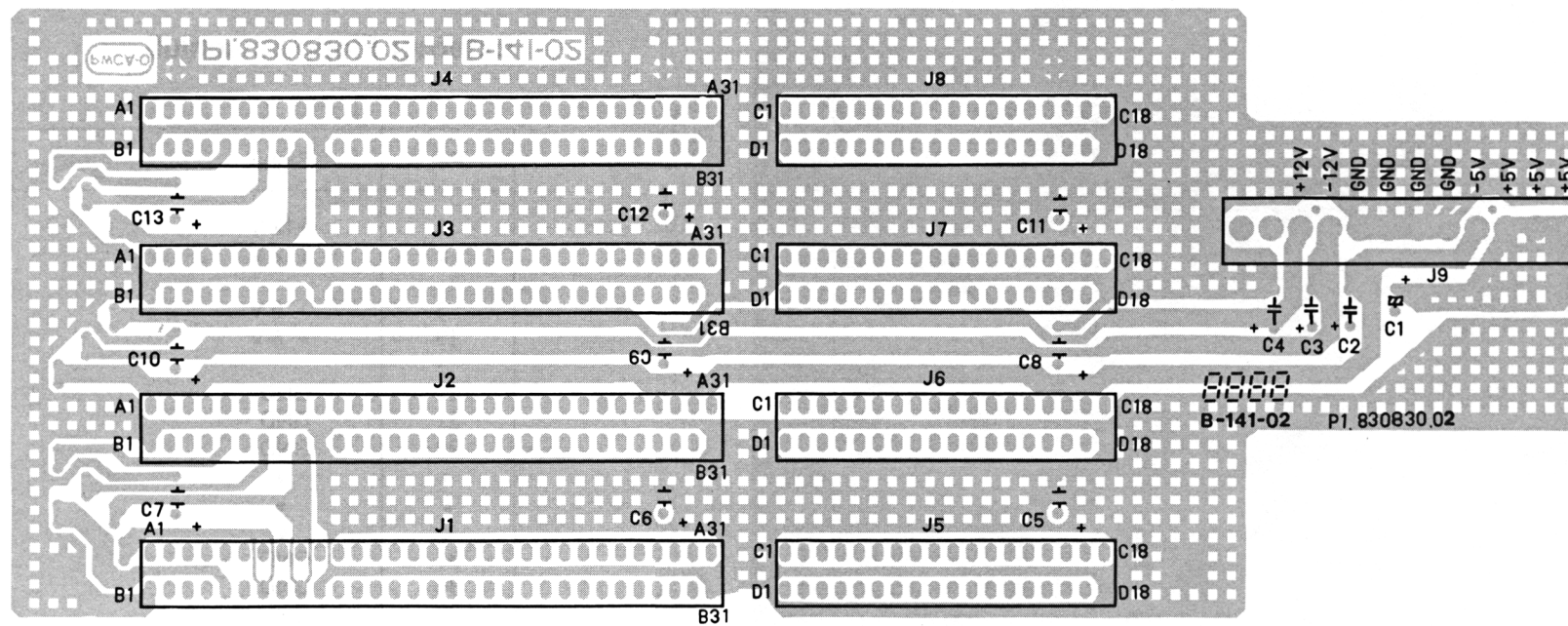

Jumper und DIP-Schalter Voreinstellung

Multi I/O

W 1	2-3
W 2	2-3
W 3	2-3
W 4	1-2
W 5	NC
W 6	1-2
W 7	2-3
W 8	1-2
W 9	NC
W 10	NC
W 11	NC
W 12	1-2

SW 1

S 1	off
S 2	off
S 3	on
S 4	off
S 5	on
S 6	off

CPU

J 1	2-3
J 2	1-2
J 7	2-3
J 13	1-2
JP 1	1-2

SW 1 MM

S 1	on
S 2	off

SW 1 EM

S 1	on
S 2	on

Externer Floppyanschluß

Pin	Signal	Pin	Signal
1	+12 V	4	Disk Ch./Ready
2	+12 V	5	High Density
3	+ 5 V	6	Index
19	+ 5 V	7	Motor ON 0
20	GND	8	Drive Select 1
21	GND	9	Drive Select 0
22	GND	10	Motor ON 1
•	•	11	Direction
•	•	12	Step
•	•	13	Write Data
35	GND	14	Write Gate
36	GND	15	Track 0
37	GND	16	Write Protect
		17	Read Data
		18	Side 1 Select

Bitte bei Ersatzteilbestellung die genaue Bezeichnung und Ident-Nr. (siehe Typenschild) des Gerätes sowie Bestell-Nummer und Positions-Nummer des Ersatzteils angeben.

For ordering of spare parts please state exact description and ident.-no. of unit (see silver rating label on the backside of unit) as well as part no. and position no. of required spare parts.

Benutzen Sie:

Telex: 531516

oder



* 3 17 298 #

oder

Telefax: 08245/51326

Service-Information**Nr. 884433**

Gerätetyp: **PC 2640** Ident.-Nr. 36523

Betrifft: Einsendungen im Servicefall
Bitte senden Sie im Servicefall die komplette Systemeinheit oder den kompletten Platinensatz (CPU, Multi I/O, SLOT) zu uns ein.

Gerätetyp: Diverse

Betrifft: Vorausersatz
Senden Sie bitte die defekten Teile immer mit der beigelegten Originalrechnung, der Garantiekarte und Fehlerbeschreibung zur Kontoentlastung an uns zurück.
Die Proformarechnung muß nicht bezahlt werden.