



Technical Handbook
VOLUME 10

DATA CONVERTERS





£2.50
\$5

©FERRANTI plc 1983

The copyright in this work is vested in Ferranti plc and this document is issued for the purpose only for which it is supplied. No licence is implied for the use of any patented feature. It must not be reproduced in whole or in part, or used for tendering or manufacturing purposes except under an agreement or with the consent in writing of Ferranti plc and then only on the condition that this notice is included in any such reproduction. Information furnished is believed to be accurate but no liability in respect of any use of it is accepted by Ferranti plc.

Issue 1, March 1983 3.5M

FERRANTI
DATA CONVERTERS
AND REFERENCES

DATA CONVERTER AND REFERENCES HANDBOOK

- CONTENTS -

Section	page
Alphanumerical Index	1-
1. Digital to Analogue Converters	1-1
Product Selection Guide	1-3
Orientation	1-5
ZN425 8 Bit D/A-A/D-Converter with Reference and Counter	1-13
ZN426 8 Bit D/A Converter with Reference	1-21
ZN428 8 Bit μ P-compatible DAC with Reference and Input Registers	1-27
ZN429 8 Bit Low Cost D/A-Converter	1-37
ZN434 4 Bit Low Cost D/A-Converter	1-43
ZN435 8 Bit D/A-A/D-Converter with Reference, Clock-Generator and Up/Down Counter	1-47
ZN436 6 Bit Low Cost D/A-Converter	1-61
2. Analogue to Digital Converters	2-1
Product Selection Guide	2-3
Orientation	2-5
ZN425 8 Bit A/D-D/A-Converter, see D/A-Section	
ZN427 8 Bit μ P-compatible Converter with Reference, successive Approximation	2-17
ZN432 10 Bit Fast Converter with Reference succ. Approx., serial and parallel Outputs	2-35
ZN432E 10 Bit Fast ADC with Reference, Low Cost Plastic Version	2-45
ZN433 10 Bit Fast ADC with Reference, Tracking System	2-53
ZN435 8 Bit A/D-D/A-Converter, see D/A-Section on-chip	
ZN440 6 Bit Flash-Converter for Video Systems	2-63
ZN447 8 Bit μ P-compatible Converter with Reference and clock-generator, successive Approximation, $\frac{1}{4}$ LSB	2-75
ZN448 8 Bit ADC, $\frac{1}{2}$ LSB Version of ZN 447	2-75
ZN449 8 Bit ADC, 1 LSB Version of ZN 447	2-75
ZN450 $3\frac{1}{2}$ Digit DVM Circuit for direct LC-Display Drive	2-97
ZNA116 $3\frac{1}{2}$ Digit DVM Circuit for MPX-LED-Displays	2-121
ZNA216 $3\frac{3}{4}$ Digit DVM Circuit for MPX-LED-Displays	2-135

3. Precision Voltage References	3-1
Product Selection Guide	3-3
ZN 404 2,45 V Precision Voltage Reference	3-5
ZN 423 1,26 V Precision Voltage Reference	3-9
ZN 458,A,B 2,45 V Precision Voltage Reference	3-17
ZN REF Series 2,5-10 V References, Summary Sheet	3-21
ZN REF 025 2,5 V Precision Voltage Reference (trimmable)	3-25
ZN REF 040 4,0 V Precision Voltage Reference (trimmable)	3-29
ZN REF 050 5,0 V Precision Voltage Reference (trmmable)	3-33
ZN REF 100 10 V Precision Voltage Reference (trimmable)	3-37
4. Codec Circuits	4-1
ZN PCM 1 Single Channel Codec	4-3
ZN PCM 2 Delta Sigma Modulator/Demodulator	4-17
5. Quality Assurance Program	5-1
6. Package Details	6-1
7. Application Notes	7-1
Applications of the ZN425 8 bit A/D-D/A-Converter	7-3
Microprocessor Interfacing using the ZN427/ZN428	7-33
Data Converters	
Direct Bus Interfacing using the ZN427/ZN428	7-59
Data Converters	
Microprocessor Interfacing using the ZN432	7-69
10 bit Data Converter	
A Serial Interface for the ZN427 A/D Converter	7-79
A Single Channel Codec (ZN PCM 1/ZN PCM 2)	7-87

ALPHANUMERICAL INDEX

		page
ZN404	2,45 V Precision Voltage Reference	3-5
ZN423	1,26 V Precision Voltage Reference	3-9
ZN425	8 Bit D/A-A/D Converter	1-13
ZN426	8 Bit D/A Converter	1-21
ZN427	8 Bit A/D Converter, μ P-compatible	2-17
ZN428	8 Bit D/A-Converter, μ P-compatible	1-27
ZN429	8 Bit D/A-Converter, Low Cost	1-37
ZN432	10 Bit A/D-Converter, Succ. Approximation	2-35
ZN432E	10 Bit A/D-Converter, Plastic, Low Cost	2-45
ZN433	10 Bit A/D-Converter, Tracking	2-53
ZN434	4 Bit D/A-Converter, Low Cost	1-43
ZN435	8 Bit D/A-A/D-Converter	1-47
ZN436	6 Bit D/A-Converter, Low Cost	1-61
ZN440	6 Bit Flash (Parallel) Video-Converter	2-63
ZN447	8 Bit A/D-Converter, μ P-compatible, 1/4 LSB	2-75
ZN448	8 Bit A/D-Converter, μ P-compatible, 1/2 LSB	2-75
ZN449	8 Bit A/D-Converter, μ P-compatible, 1 LSB	2-75
ZN450	3 1/2 Digit DVM-Circuit for LC-Displays	2-97
ZN458,A,B	2,45 V Precision Voltage Reference	3-17
ZNA116	3 1/2 Digit DVM-Circuit for MPX-LED-Displays	2-121
ZNA216	3 3/4 Digit DVM-Circuit for MPX-LED-Displays	2-135
ZN PCM1	Single Channel Codec	4-3
ZN PCM2	Delta Sigma Modulator/Demodulator	4-17
ZN REF 025	2,5 V Precision Voltage Reference (trimmable)	3-25
ZN REF 040	4,0 V Precision Voltage Reference (trimmable)	3-29
ZN REF 050	5,0 V Precision Voltage Reference (trimmable)	3-33
ZN REF 100	10,0 V Precision Voltage Reference (trimmable)	3-37

1. Digital-to-Analogue Converters

Contents

	page
Selection Guide	1-3
Orientation	1-5
ZN 425	1-13
ZN 426	1-21
ZN 428	1-27
ZN 429	1-37
ZN 434	1-43
ZN 435	1-47
ZN 436	1-61

PRODUCT SELECTION GUIDE D TO A CONVERTERS

TYPE	USEFUL RESOLUTION (BITS)	SETTLING TIME (μ s)	ON-CHIP REFERENCE	INPUT LATCH	TEMPERATURE RANGE (°C)	FEATURES	PAGE
ZN425E SERIES	8 to 6	1	+	-	0 to 70	D to A with on-chip counter	1-13
ZN425J-8	8	1	+	-	-55 to +125	D to A with on-chip counter	1-13
ZN426E SERIES	8 to 6	1	+	-	0 to 70	TTL and CMOS compatible	1-21
ZN426J-8	8	1	+	-	-55 to +125	TTL and CMOS compatible	1-21
ZN428E-8	8	0,8	+	+	0 to 70	Microprocessor, TTL and CMOS compatible	1-27
ZN428J-8	8	0,8	+	+	-55 to +125	Microprocessor, TTL and CMOS compatible	1-27
ZN429E-8	8	1	-	-	0 to 70	Low cost, TTL and CMOS compatible	1-37
ZN429J-8	8	1	-	-	-55 to +125	Low cost, TTL and CMOS compatible	1-37
ZN434E	4	0,3	$V_{cc}/2$	-	0 to 70	Low cost, TTL and CMOS compatible	1-43
ZN435E	8	0,8	+	-	0 to 70	D to A, up/down counter, clock-generator	1-47
ZN435J	8	0,8	+	-	-55 to +125	D to A, up/down counter, clock-generator	1-47
ZN436E	6	1	-	-	0 to 70	Low cost, TTL and CMOS compatible	1-61
ZN436J	6	1	-	-	-55 to +125	Low cost, TTL and CMOS compatible	1-61

1. DIGITAL TO ANALOGUE CONVERTERS

A Digital to Analogue converter (DAC) is a device which converts a digital data input into a corresponding analogue output. This output usually takes the form of a voltage or current.

1.1 Ideal Output Characteristics

If a unipolar voltage output and normal binary input coding are assumed, then the ideal transfer function of a linear DAC may be written as:

$$V_{\text{out}} = V_{\text{FS}} (B_1 \cdot 2^{-1} + B_2 \cdot 2^{-2} + B_3 \cdot 2^{-3} + \dots + B_n \cdot 2^{-n})$$

where B_1 is the most significant bit input (MSB) and B_n is the least significant bit input (LSB). Bits 1 to n can each assume a value of '1' or '0'. The number of bit inputs a DAC possesses is known as the RESOLUTION of the converter.

The smallest increment of output voltage is that contributed by the LSB and is equal to $V_{\text{FS}} \cdot 2^{-n}$.

The terms 'MSB', 'LSB' etc., are frequently used interchangeably to describe either the digital input or the corresponding analogue output.

The maximum output from a DAC is known as full-scale output (V_{FSO}).

It occurs when all inputs are '1' and is equal to $V_{\text{FS}} \left(\frac{2^n - 1}{2^n} \right)$. For example the maximum output of a 3-bit DAC is $\frac{7}{8} V_{\text{FS}}$.

The transfer function graph of an ideal 3-bit DAC is shown in figure 1. For each of the 8 input codes there exists a discrete analogue output

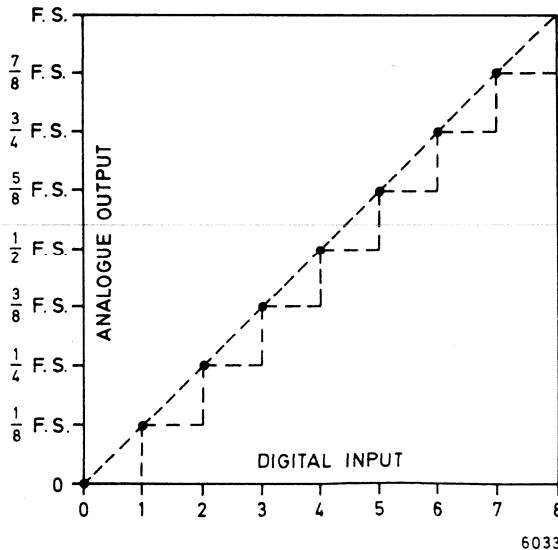

6033

Fig. 1. Transfer Characteristic of Ideal 3-bit DAC

D to A Converters

level, represented by a point on the graph. It should be emphasised that the transfer characteristic is not a continuous function and it is, therefore, not strictly correct to join the points with a continuous line, since this would imply that non-integral input codes and corresponding levels existed. However, a straight line is often drawn between zero and full scale to represent the 'ideal' transfer function on which all the points should lie.

Similarly, if the input code of a DAC is incremented using, say, a binary counter and clock generator, then the analogue output will be a staircase waveform. DAC transfer functions are frequently drawn as a staircase, since this is a convenient way of illustrating various errors that may occur in a DAC. However, such a graph is, strictly speaking, a plot of analogue output v. time rather than output v. input code.

1.2 Practical DAC Circuits

Figure 2 shows an example of a 3-bit DAC circuit based on a voltage-switching R-2R ladder network, a technique widely used in Ferranti converters.

Each 2R element is connected either to 0 volts or V_{FS} (V_{REF}) by transistor switches. Binary weighted voltages are produced at the output of the R-2R ladder, the value being proportional to the digital input number.

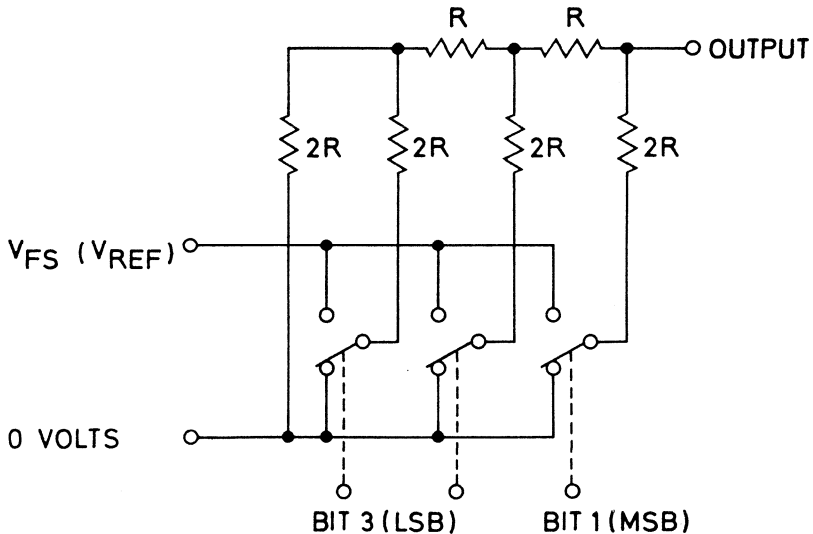

Fig. 2. 3-bit Voltage Switching DAC

D to A Converters

For example, it is fairly easy to see that if bit 1 is '1' and bits 2 and 3 are '0' then an output of $V_{FS}/2$ is produced. This is because the resistance of the ladder looking from the output through the first R is 2R, which forms a 2:1 attenuator with the 2R in series with the MSB switch. Output voltages for other input codes can similarly be calculated, and it can be seen that the ladder may be extended to any number of bits.

The voltage switching ladder technique is used in the ZN426, ZN428 and ZN429 series of D to A converters and also in the ZN425 dual-purpose A to D/D to A converter.

1.3 D to A Parameters and Definitions

1.3.1 Converter Errors

The ideal DAC assumes that all the resistors are perfectly matched and that the switches have zero resistance. In a practical converter this will not be the case and various errors will occur in the output.

1.3.2 Monotonicity

When the input code of a DAC is increased in 1 LSB steps the analogue output of the DAC should also increase, staircase fashion. If the output always increases in this manner then the DAC is said to be monotonic, i.e. the output is a single-valued function of the input. If, due to errors in the bit weighting, the output of the DAC decreases at any step, as shown in figure 3, then the DAC is said to be non-monotonic.

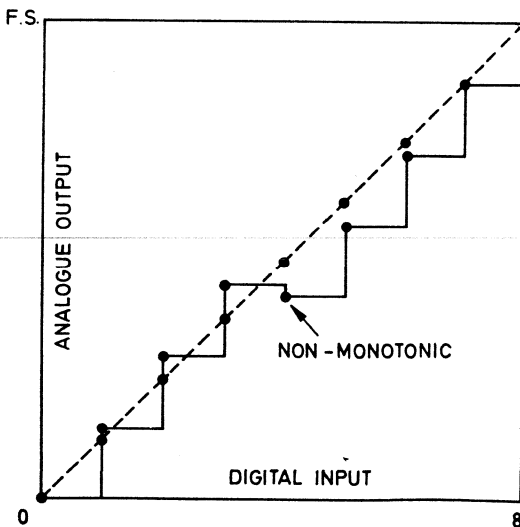

5036

Fig. 3. Non-monotonic DAC

D to A Converters

1.3.3 Offset (Zero Error)

Assuming unipolar operation and normal binary coding, when the input code is zero then the DAC output should also be zero. However, due to package lead resistances and offset voltages in the switches this will not be the case, and a small output offset may exist. This has the effect of shifting the transfer function so that it no longer passes through zero, as shown in figure 4.

1.3.4 Gain Error

If the reference voltage of a DAC is exactly the nominal value then the transfer characteristics of the converter should follow the ideal straight line. However, due to imperfections in the converter the transfer function may diverge from this line, as shown in figure 4. This error is known as gain error and is the difference between the slope of the actual transfer characteristic and the slope of the ideal transfer characteristic.

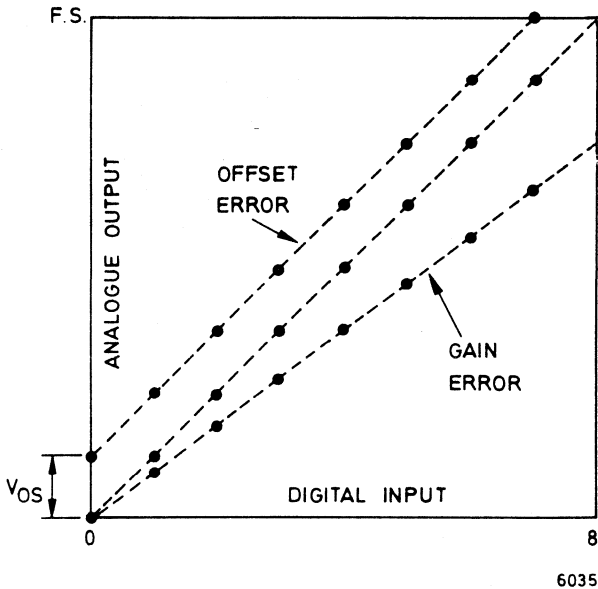

Fig. 4. Illustrating Offset and Gain Errors

1.3.5 Linearity Errors

Offset and gain errors may be trimmed out so that the end points of the transfer characteristic lie at zero and V_{FSO} . However, even when this has been done, some or all of the intermediate points may not lie on the 'ideal' line. These errors, which cannot be trimmed out, are known as linearity errors.

D to A Converters

1.3.6 Non-Linearity (Linearity Error)

This is the maximum amount, given either as a percentage of full scale or a fraction of an LSB, by which any point on the transfer characteristic deviates from the ideal straight line passing through zero and V_{FSO} . Non-linearity is illustrated in figure 5. A linearity error within the range $\pm \frac{1}{2}$ LSB assures monotonic operation. Note however that the converse is not true and a DAC may still be monotonic with large linearity errors, which is also shown by figure 5.

1.3.7 Differential Non-linearity

This is the maximum difference, specified as a fraction of an LSB, between the actual and ideal size of any one LSB analogue increment. This can be seen as an error in the step height of a DAC staircase. A positive value of differential non-linearity means that the step height is larger than nominal, whilst a negative value means that it is smaller than nominal. If it is more negative than -1 LSB then the DAC is non-monotonic. However, positive differential non-linearity may assume any value and a DAC can still be monotonic, as shown in figure 5.

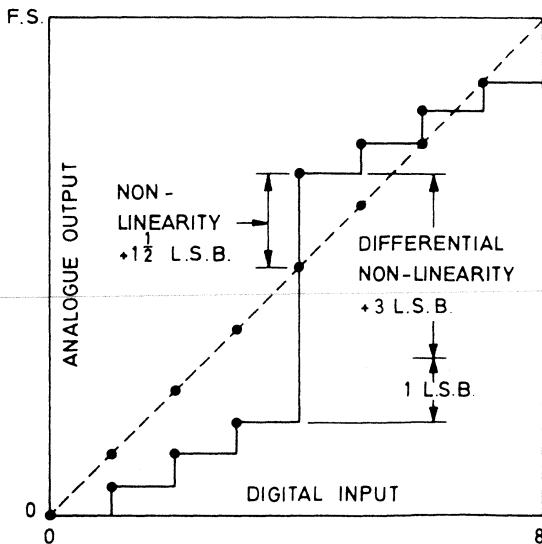

6037

Fig. 5. Illustrating Linearity Errors

D to A Converters

1.3.8 Resolution

As stated earlier, the resolution of a DAC is simply the number of bit inputs that a DAC possesses, which indicates the smallest analogue increment that the converter can produce as a fraction of V_{FS} , e.g. 8 bits = 1 part in 2^8 (256). Resolution implies nothing about the accuracy of a DAC, which is defined by linearity and other errors.

1.3.9 Useful Resolution

If an n bit DAC has a differential non-linearity of say -1.5 LSB then it is non-monotonic. However, if the LSB input is made permanently '0' then the DAC becomes an $n-1$ bit device with an LSB equal to twice the original LSB. The differential non-linearity error thus becomes -0.75 (new) LSB and the device is monotonic at a resolution of $n-1$ bits. This is illustrated in figure 6, which shows the transfer characteristic of a 3-bit DAC that has a useful resolution of 2 bits.

Due to manufacturing tolerances a proportion of n -bit converters will have only $n-1$ or $n-2$ bit useful resolution. In applications not requiring n -bit useful resolution these reduced resolution versions offer a significant price advantage. The useful resolution of Ferranti DACs is guaranteed over their full operating temperature range.

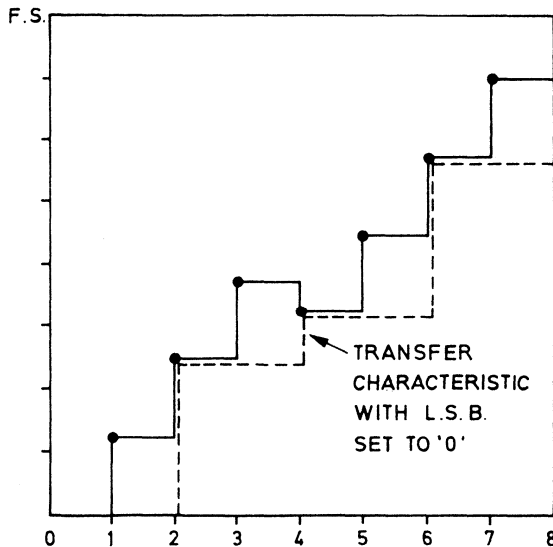

6053

Fig. 6. Non-monotonic 3-bit DAC With a Useful Resolution of 2 bits

D to A Converters

1.3.10 Settling Time is the time taken after a transition of the input code for the output of a DAC to settle to within $\pm \frac{1}{2}$ LSB of its final value. This varies depending on which bits are being changed. It may be specified for a change of 1 LSB which generally gives the most optimistic (fastest) figure. More conservative figures are given by the most major transition (where the MSB changes in one direction and all other bits change in the opposite direction, e.g. 01111111 to 10000000 or vice versa) or by a change from all bits off to all bits on (00000000 to 11111111) or vice versa.

1.4 Bipolar Operation

The discussion so far has been concerned only with DACs producing a single polarity (usually positive) output voltage. In some applications a bipolar (both positive and negative) output range may be required.

This can be achieved by adding a negative offset of $\frac{V_{REF}}{2}$ to the analogue output, as shown in figure 7. For all input codes where the MSB is '0' the output voltage is then negative, and for output codes where the MSB is '1' the output voltage is positive. Where the input coding is normally binary but the output voltage is offset by $\frac{-V_{REF}}{2}$ then the input code is referred to as offset binary.

The transfer function of a 3-bit DAC with offset binary coding is shown in figure 8.

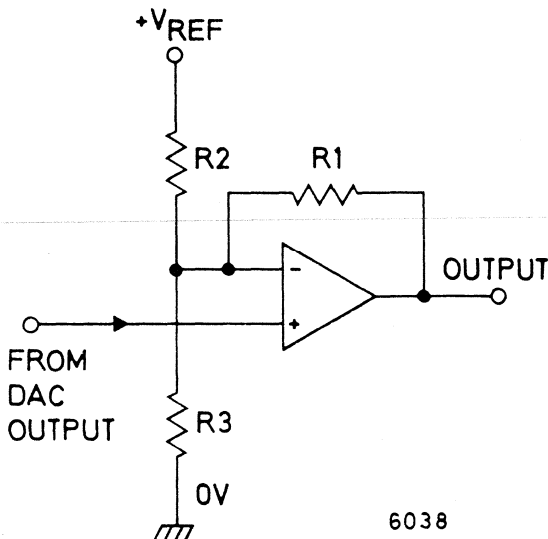
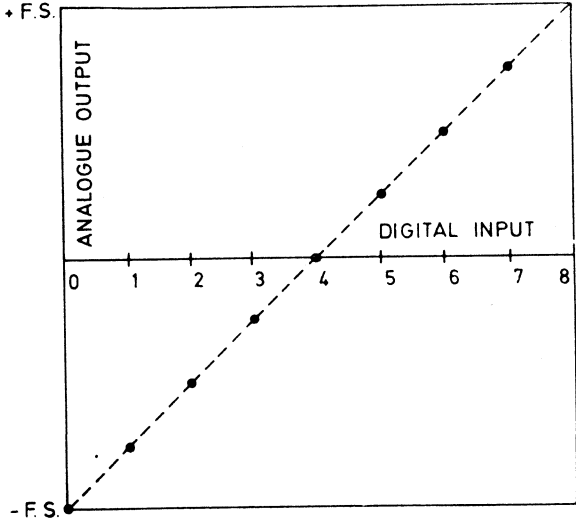

Fig. 7. Bipolar Operation of a DAC

D to A Converters



6039

Fig. 8. Bipolar Operation of a 3-bit DAC

8 Bit Monolithic D to A/A to D Converter

FEATURES

- 8, 7 and 6 bit Accuracy
- 0°C to +70°C (ZN425E Series)
- -55°C to +125°C (ZN425J-8)
- TTL and 5V CMOS Compatible
- Single +5V Supply
- Settling Time (D to A) 1 μ sec Typical
- Conversion Time (A to D) 1 msec typical, using ramp and compare.
- Extra Components Required

D-A : Reference capacitor (direct voltage output through 10 k Ω typ.)

A-D : Comparator, gate, clock and reference capacitor

DESCRIPTION

The ZN425 is a monolithic 8-bit digital to analogue converter containing an R-2R ladder network of diffused resistors with precision bipolar switches, and in addition a counter and a 2.5V precision voltage reference. The counter is a powerful addition which allows a precision staircase to be generated very simply merely by clocking the counter.

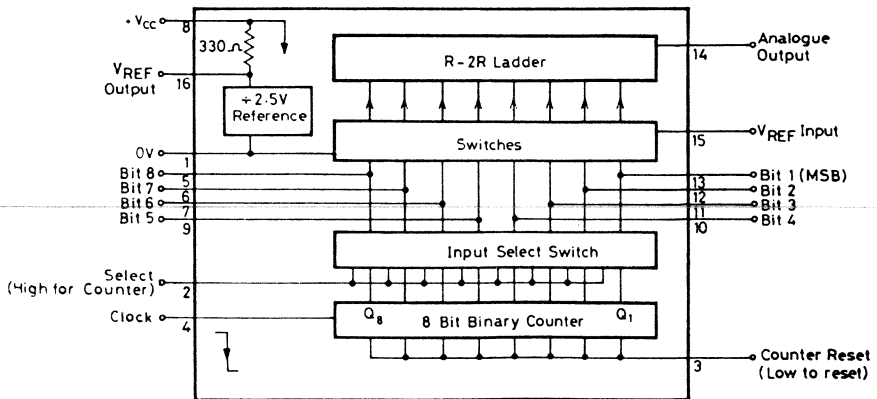

Fig. 1 - System Diagram

441/2

ZN425 Series

INTRODUCTION

The ZN425 is an 8-bit dual mode digital to analogue/analogue to digital converter. It contains an 8-bit D to A converter using an advanced design of R-2R ladder network and an array of precision bipolar switches plus an 8-bit binary counter and a 2.5 volt precision voltage reference all on a single monolithic chip.

The special design of ladder network results in full 8-bit accuracy using normal diffused resistors.

The use of the on-chip reference voltage is pin optional to retain flexibility. An external fixed or varying reference may therefore be substituted.

By including on the chip an 8-bit binary counter, analogue to digital conversion can be obtained simply by adding an external comparator (ZN424P) and clock inhibit gating (ZN7400E).

By simply clocking the counter the ZN425 can be used as a self-contained precision ramp generator.

A logic input select switch is incorporated which determines whether the precision switches accept the outputs from the binary counter or external digital inputs depending upon whether the control signal is respectively high or low.

The converter is of the voltage switching type and uses an R-2R resistor ladder network as shown in Fig. 2.

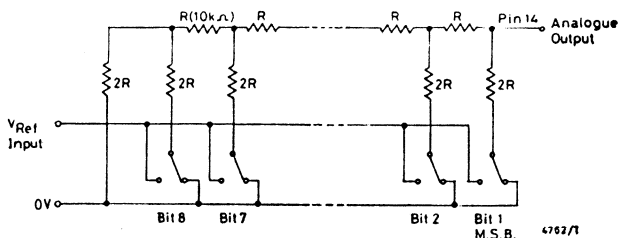

Fig. 2 – The R-2R Ladder Network

Each 2R element is connected either to 0V or V_{REF} by transistor switches specially designed for low offset voltage (typically 1 millivolt).

Binary weighted voltages are produced at the output of the R-2R ladder, the value depending on the digital number applied to the bit inputs.

ORDERING INFORMATION

Operating Temperature	8-bit Accuracy	7-bit Accuracy	6-bit Accuracy	Package
0°C to +70°C	ZN425E-8	ZN425E-7	ZN425E-6	Plastic
-55°C to +125°C	ZN425J-8	—	—	Ceramic

ABSOLUTE MAXIMUM RATINGS

Supply voltage V_{CC}	+7.0 volts
Max. voltage, logic and V_{REF} inputs	+5.5 volts <i>See note 3</i>
Operating temperature range	0°C to +70°C (ZN425E Series) -55°C to +125°C (ZN425J-8)
Storage temperature range	-55°C to +125°C

ZN425 Series

CHARACTERISTICS (at $T_{amb} = 25^{\circ}\text{C}$ and $V_{CC} = +5$ volts unless otherwise specified).

Internal voltage reference

Parameter	Symbol	Min.	Typ.	Max.	Units	Conditions
Output voltage	V_{REF}	2.4	2.55	2.7	volts	$I = 7.5$ mA (internal)
Slope resistance	R_s	—	2	4	ohms	$I = 7.5$ mA (internal)
V_{REF} Temperature coefficient		—	40	—	ppm/ $^{\circ}\text{C}$	$I = 7.5$ mA (internal)

Note: The internal reference requires a $0.22 \mu\text{F}$ stabilising capacitor between pins 1 and 16.

8-Bit D to A Converter and Counter

Parameter	Symbol	Min.	Typ.	Max.	Units	Conditions
Resolution		8	—	—	bits	
Accuracy (useful resolution)	ZN425J-8 ZN425E-8 ZN425E-7 ZN425E-6	8 8 7 6	— — — —	— — — —	bits bits bits bits	V_{REF} Input = 2 to 3V
Non-linearity		—	—	± 0.5	L.S.B.	See Note 3
Differential non-linearity		—	± 0.5	—	L.S.B.	See Note 6
Settling time		—	1.0	—	μs	1 L.S.B. step
Settling time to 0.5 L.S.B.		—	1.5	2.5	μs	All bits ON to OFF or OFF to ON
Offset voltage	ZN425J-8 } ZN425E-8 } ZN425E-6 } ZN425E-7 }	V_{OS} — —	8 3	12 8	mV mV	All bits OFF See Note 3
Full scale output		2.545	2.550	2.555	volts	All bits ON Ext. $V_{REF} = 2.56\text{V}$
Full scale temperature coeff.		—	3	—	ppm/ $^{\circ}\text{C}$	Ext. $V_{REF} = 2.56\text{V}$
Non-linearity error temp. coeff.		—	7.5	—	ppm/ $^{\circ}\text{C}$	Relative to F.S.R.
Analogue output resistance	R_o	—	10	—	$\text{k}\Omega$	
External reference voltage		0	—	3.0	volts	
Supply voltage	V_{CC}	4.5	—	5.5	volts	See Note 3
Supply current	I_s	—	25	35	mA	
High level input voltage	V_{IH}	2.0	—	—	volts	See Notes 1 and 2
Low level input voltage	V_{IL}	—	—	0.7	volts	

ZN425 Series

CHARACTERISTICS (continued).

Parameter	Symbol	Min.	Typ.	Max.	Units	Conditions
High level input current	I_{IH}	—	—	10	μA	$V_{CC} = \text{max.}$ $V_I = 2.4\text{V}$
		—	—	100	μA	$V_{CC} = \text{max.}$ $V_I = 5.5\text{V}$
Low level input current, bit inputs	I_{IL}	—	—	-0.68	mA	$V_{CC} = \text{max.}$ $V_I = 0.3\text{V}$
Low level input current, clock reset and input select	I_L	—	—	-0.18	mA	
High level output current	I_{OH}	—	—	-40	μA	
Low level output current	I_{OL}	—	—	1.6	mA	
High level output voltage	V_{OH}	2.4	—	—	volts	$V_{CC} = \text{min.}$ $Q = 1$ $I_{load} = -40 \mu\text{A}$
Low level output voltage	V_{OL}	—	—	0.4	volts	$V_{CC} = \text{min.}$ $Q = 0$ $I_{load} = 1.6 \text{ mA}$
Maximum counter clock frequency	f_c	3	5	—	MHz	See Note 5
Reset pulse width	t_R	200	—	—	ns	See Note 4

Notes:

- The Input Select pin (2) must be held low when the bit pins (5, 6, 7, 9, 10, 11, 12 and 13) are driven externally.
- To obtain counter outputs on bit pins the Input Select pin (2) should be taken to $+V_{CC}$ via a 1 k Ω resistor.
- The ZN425J differs from the ZN425E in the following respects:
 - For the ZN425J, the maximum linearity error may increase to ± 1 LSB over the temperature ranges -55°C to 0°C and $+70^\circ\text{C}$ to $+125^\circ\text{C}$.
 - Maximum operating voltage. Between 70°C and 125°C the maximum supply voltage is reduced to 5.0V.
 - Offset voltage. The difference is due to package lead resistance. This offset will normally be removed by the setting up procedure, and because the offset temperature coefficient is low, the specified accuracy will be maintained.
- The device may be reset by gating from its own counter.
- F_{max} in A/D mode is 300 kHz, see page 1-18
- Monotonic over full operating temperature range at resolution appropriate to accuracy.

ZN425 Series

If Pin 2 is high then the output equals the Q output of the corresponding counter.

If Pin 2 is low then the output transistor, Tr1 is held off.

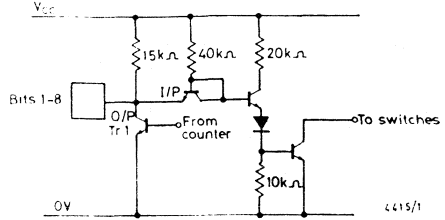

Fig. 3 – Bit Inputs/Outputs

APPLICATIONS

1. 8-bit D to A Converter

The ZN425 gives an analogue voltage output directly from pin 14 therefore the usual current to voltage converting amplifier is not required. The output voltage drift, due to the temperature coefficient of the Analogue Output Resistance R_o , will be less than 0.004% per °C (or 1 L.S.B./100°C) if R_L is chosen to be $\geq 650 \text{ k}\Omega$.

In order to remove the offset voltage and to calibrate the converter a buffer amplifier is necessary. Fig. 4 shows a typical scheme using the internal reference voltage. To minimise temperature drift in this and similar applications the source resistance to the inverting input of the operational amplifier should be approximately 6 kΩ. The calibration procedure is as follows:

- i. Set all bits to OFF (low) and adjust R_2 until $V_{out} = 0.000V$.
- ii. Set all bits to ON (high) and adjust R_1 until $V_{out} = \text{Nominal full scale reading} - 1 \text{ L.S.B.}$
- iii. Repeat i. and ii.

e.g. Set F.S.R. to +3.840 volts – 1 L.S.B.
 $= 3.825 \text{ volts}$
 $(1 \text{ L.S.B.} = \frac{3.84}{256} = 15.0 \text{ millivolts.})$

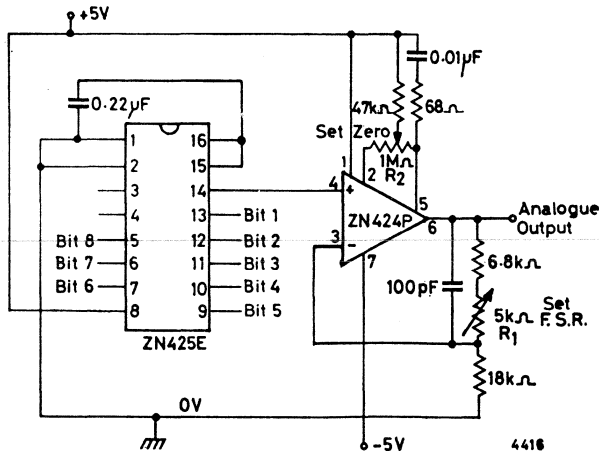

Fig. 4 – 8-bit Digital to Analogue Converter

ZN425 Series

2. 8-bit Analogue to Digital Converter

A counter type ADC can be constructed by adding a voltage comparator and a latch as in Fig. 5. On the negative edge of the CONVERT COMMAND pulse (15 μ s minimum) the counter is set to zero and the STATUS latch to logical 1. On the positive edge the gate is opened, enabling clock pulses to be fed to the counter input of the ZN425. The minimum negative clock pulse width to the ZN425 is 100 ns. The analogue output of the ZN425 ramps until it equals the voltage on the other input of the comparator. At this point the comparator output goes low and resets the STATUS latch to inhibit further clock pulses. The logical 0 from the status latch indicates that the 8 bit digital output is a valid representation of the analogue input voltage.

A small capacitor of 47 pF is added to the ZN425 output to stop any positive going glitches prematurely resetting the status latch. This capacitance is in parallel with the ZN425 output capacitance (20–30 pF) and they form a time constant with the ZN425 output resistance (10 k Ω). This time constant is the main limit to the maximum clock frequency. With a fast comparator the clock frequency can be up to 300 kHz. Using the ZN424P as a comparator the clock frequency should be restricted to 100 kHz. The conversion time varies with the input, being a maximum for full scale input.

$$\text{Maximum conversion time} = \frac{256}{\text{clock frequency in Hz}} \text{ seconds}$$

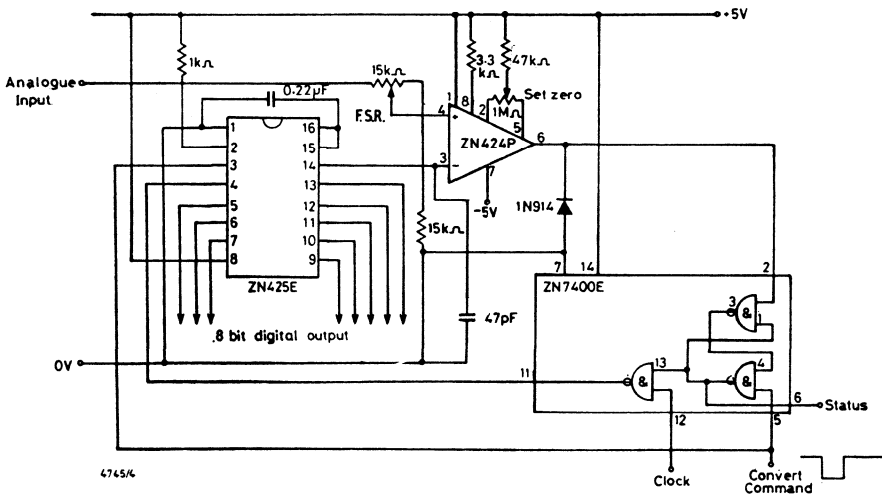

Fig. 5 – 8-bit Analogue to Digital Converter

3. Precision Ramp Generator

The inclusion of an 8-bit binary counter on the chip gives the ZN425 a useful ramp generator function. The circuit, Fig. 6 uses the same buffer stages as the D to A converter. The calibration procedure is also the same. Holding pin 2 low will set all bits to ON and if RESET is taken low with pin 2 high all the bits are turned OFF. If the end voltages of the ramp are not required to be set accurately then the buffer stage could be omitted and the voltage ramp will appear directly at pin 14.

ZN425 Series

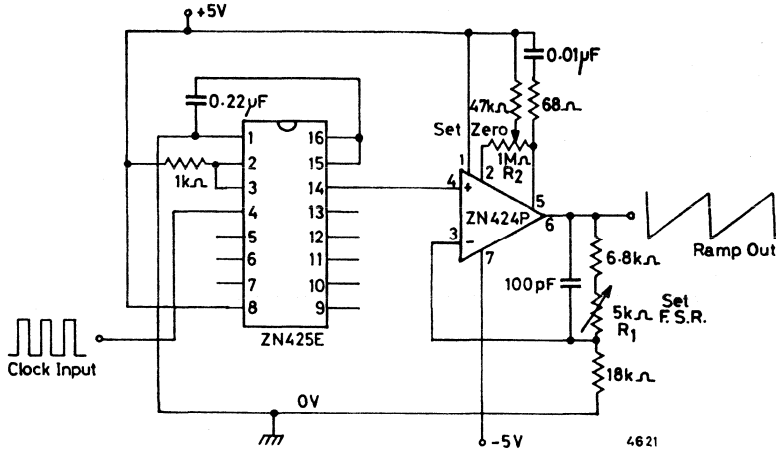

Fig. 6 – Precision Ramp Generator

4. Alternative Output Buffer using the ZLD741

The following circuit, employing the ZLD741 operational amplifier, may be used as the output buffer for both the 8-bit Digital to Analogue Converter (Fig. 4) and the Precision Ramp Generator (Fig. 6).

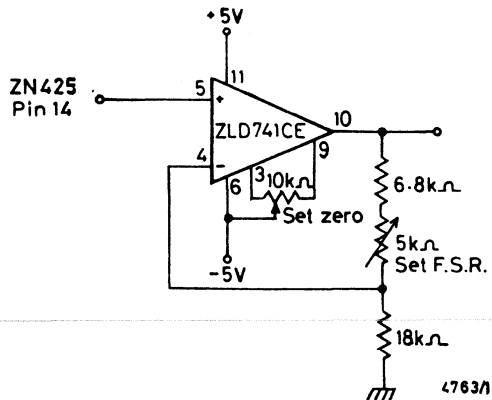

Fig. 7 – The ZLD741 as Output Buffer

5. Further Applications

Details of a wide range of additional applications, described in the Ferranti publication 'Application Report-ZN425 8-bit A-D/D-A Converter', are also available.

ZN425 Series

PIN CONNECTIONS

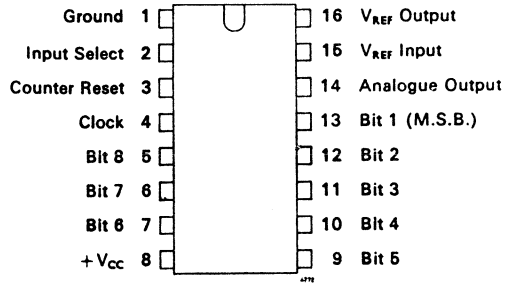

CHIP DIMENSIONS AND LAYOUT

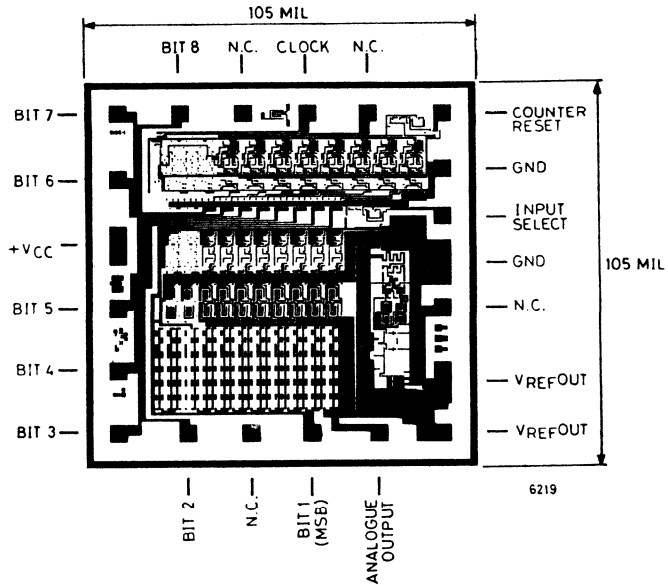

8 Bit Monolithic D to A Converter

FEATURES

- 8, 7 and 6-bit Accuracy
- ZN426E Series Commercial Temp. Range 0°C to +70°C
- ZN426J-8 Military Temp. Range -55°C to +125°C
- TTL and 5V CMOS Compatible
- Single +5V Supply
- Settling Time 1 μsec. Typical
- Only Reference Capacitor and Resistor required

DESCRIPTION

The ZN426 is a monolithic 8-bit digital to analogue converter containing an R-2R ladder network of diffused resistors with precision bipolar switches and a 2.5V precision voltage reference.

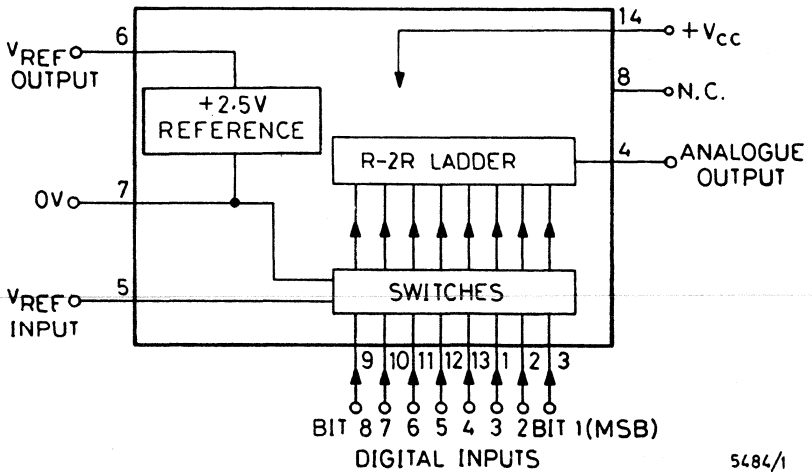

Fig. 1. System Diagram

5484/1

ZN426 Series

INTRODUCTION

The ZN426 is an 8-bit digital to analogue converter. It contains an advanced design of R-2R ladder network and an array of precision bipolar switches plus a 2.5 volt precision voltage reference all on a single monolithic chip.

The special design of ladder network results in full 8-bit accuracy using normal diffused resistors.

The use of the on-chip reference voltage is pin optional to retain flexibility. An external fixed or varying reference may therefore be substituted. In this case there is no need to supply power to the internal reference so R_{REF} and C_{REF} can be omitted.

The converter is of the voltage switching type and uses an R-2R resistor ladder network as shown in Fig. 2.

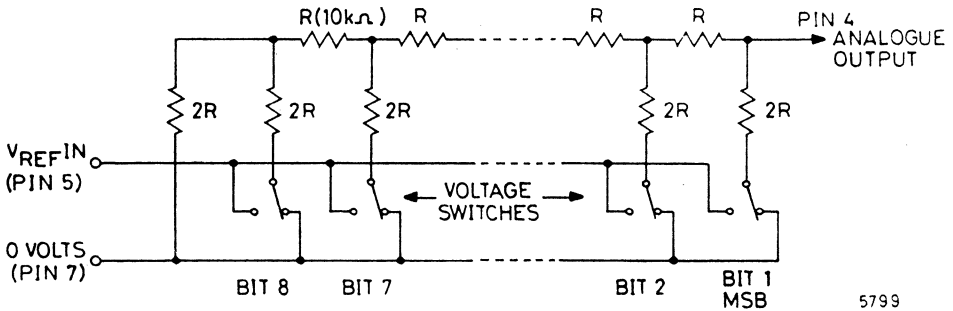

Fig. 2. The R-2R Ladder Network

Each $2R$ element is connected either to $0V$ or V_{REF} by transistor switches specially designed for low offset voltage (typically 1 millivolt).

Binary weighted voltages are produced at the output of the R-2R ladder. the value depending on the digital number applied to the bit inputs.

ORDERING INFORMATION

Operating Temperature	8-bit accuracy	7-bit accuracy	6-bit accuracy	Package
0 to +70°C	ZN426E-8	ZN426E-7	ZN426E-6	Plastic
-55 to +125°C	ZN426J-8	—	—	Ceramic

ABSOLUTE MAXIMUM RATINGS

Supply voltage V_{CC}	+7.0 volts
Max. voltage, logic and V_{REF} inputs	+5.5 volts
Storage temperature range	-55 to +125°C

ZN426 Series

ELECTRICAL CHARACTERISTICS ($V_{CC} = +5$ volts, $T_{amb} = 25^{\circ}\text{C}$ unless otherwise specified).

Parameter	Symbol	Min.	Typ.	Max.	Units	Conditions
Converter Resolution		8	—	—	bits	
Accuracy (useful resolution)		8	—	—	bits	V_{REF} input = 2.0 to 3.0 volts
ZN426J-8	}	8	—	—	bits	
ZN426E-8		7	—	—	bits	
ZN426E-7		6	—	—	bits	
ZN426E-6		6	—	—	bits	
Non-linearity		—	—	± 0.5	L.S.B.	<i>Note 1</i>
Differential non-linearity		—	± 0.5	—	L.S.B.	<i>Note 2</i>
Settling time to 0.5 L.S.B.		—	1.0	—	μs	1 L.S.B. step
Settling time to 0.5 L.S.B.		—	2.0	—	μs	All bits ON to OFF or OFF to ON
Offset voltage	} V_{OS}	—	5.0	8.0	mV	All bits OFF <i>Note 1</i>
ZN426J-8		—	3.0	5.0	mV	
ZN426E-8		—	3.0	5.0	mV	
ZN426E-7		—	3.0	5.0	mV	
ZN426E-6	—	3.0	5.0	mV		
V_{OS} temperature coefficient		—	5	—	$\mu\text{V}/^{\circ}\text{C}$	
Full scale output		2.545	2.550	2.555	volts	All bits ON Ext. $V_{REF} = 2.560\text{V}$
Full scale temp. coefficient		—	3	—	ppm/ $^{\circ}\text{C}$	Ext. $V_{REF} = 2.560\text{V}$
Non-linearity temp. coeff.		—	7.5	—	ppm/ $^{\circ}\text{C}$	Relative to F.S.R.

Notes:

- The ZN426J-8 differs from the ZN426E-8 in the following respects :
 - For the ZN426J-8, the maximum linearity error may increase to $\pm 0.4\%$ FSR i.e. ± 1 LSB over the temperature ranges -55°C to 0°C and $+70^{\circ}\text{C}$ to $+125^{\circ}\text{C}$.
 - Offset voltage. The difference is due to package lead resistance. This offset will normally be removed by the setting up procedure, and because the offset temperature coefficient is low, the specified accuracy will be maintained.
- Monotonic over full temperature range at resolution appropriate to accuracy.

ZN426 Series

ELECTRICAL CHARACTERISTICS (continued)

Parameter	Symbol	Min.	Typ.	Max.	Units	Conditions
Analogue output resistance	R_o	—	10	—	k Ω	
External reference voltage		0	—	3.0	volts	
Supply voltage	V_{CC}	4.5	—	5.5	Volts	
Supply current	I_s	—	5	9	mA	
High level input voltage	V_{IH}	2.0	—	—	volts	
Low level input voltage	V_{IL}	—	—	0.7	volts	
High level input current	I_{IH}	—	—	10	μ A	$V_{CC} = \text{max.},$ $V_I = 2.4V$
		—	—	100	μ A	$V_{CC} = \text{max.},$ $V_I = 5.5V$
Low level input current	I_{IL}	—	—	-0.18	mA	$V_{CC} = \text{max.},$ $V_I = 0.3V$
Internal Voltage Reference Output voltage	V_{REF}	2.475	2.55	2.625	volts	<i>Note*</i> $R_{REF} = 390\Omega$
Slope resistance	R_s	—	1	2	ohms	$R_{REF} = 390\Omega$
V_{REF} temperature coefficient		—	40	—	ppm/ $^{\circ}$ C	$R_{REF} = 390\Omega$

*Note** The internal reference requires a 1 μ F stabilising capacitor between pins 7 and 6 (C_{REF}) and a 390 Ω resistor between pins 14 and 6 (R_{REF}).

APPLICATIONS

1. 8-bit D to A Converter

The ZN426 gives an analogue voltage output directly from pin 4 therefore the usual current to voltage converting amplifier is not required. The output voltage drift, due to the temperature coefficient of the Analogue Output Resistance R_o , will be less than 0.004% per $^{\circ}$ C (or 1 L.S.B./100 $^{\circ}$ C) if R_L is chosen to be ≥ 650 k Ω

In order to remove the offset voltage and to calibrate the converter a buffer amplifier is necessary. Fig. 3 shows a typical scheme using the internal reference voltage. To minimise temperature drift in this and similar applications the source resistance to the inverting input of the operational amplifier should be approximately 6 k Ω . The calibration procedure is as follows:

- i. Set all bits to OFF (low) and adjust R_2 until $V_{out} = 0.000V$.
- ii. Set all bits to ON (high) and adjust R_1 until $V_{out} = \text{Nominal full scale reading} - 1 \text{ L.S.B.}$
- iii. Repeat i. and ii.

e.g. Set F.S.R. to +3.840 volts - 1 L.S.B. = 3.825 volts

$$(1 \text{ L.S.B.} = \frac{3.84}{256} = 15.0 \text{ millivolts.})$$

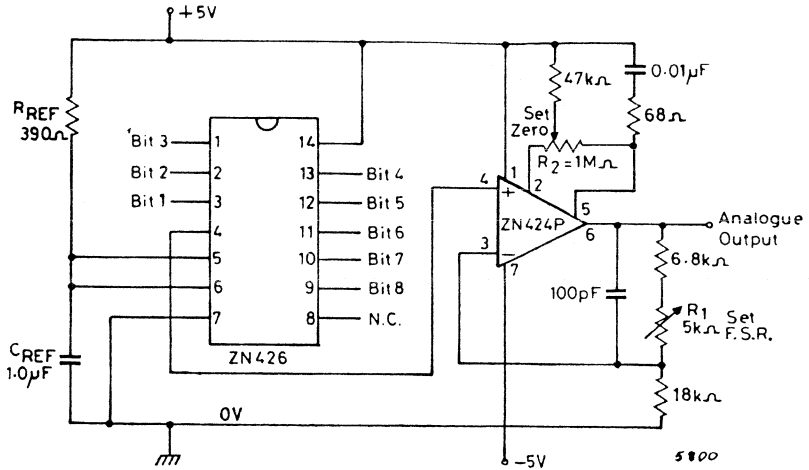

Fig. 3. 8-bit Digital to Analogue Converter

Alternative Output Buffer using the ZLD741

The following circuit, employing the ZLD741 operational amplifier, may be used as the output buffer (Fig. 3).

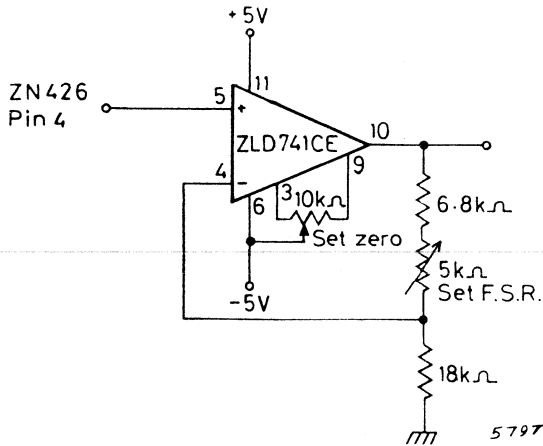
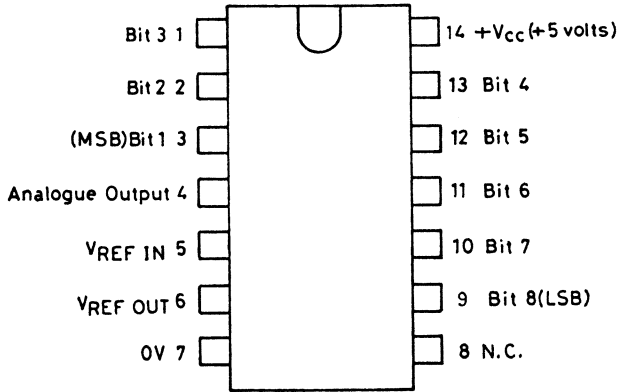

Fig. 4. The ZLD741 as Output Buffer

ZN426 Series

PIN CONNECTIONS



5798

CHIP DIMENSIONS AND LAYOUT

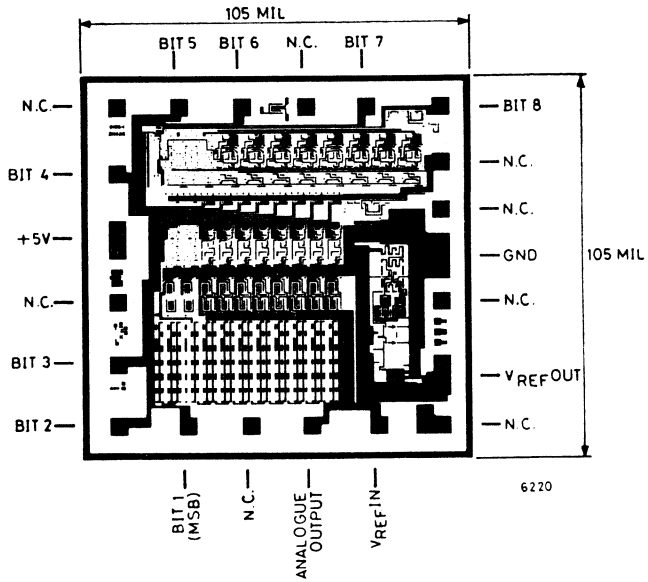



8 Bit Latched Input Monolithic D to A Converter

FEATURES

- Contains DAC with data latch and on-chip reference.
- Guaranteed monotonic over the full operating temperature range
- Single +5V supply ● Microprocessor compatible
- TTL and 5V CMOS compatible
- 800 ns settling time ● Complementary to ZN427 A to D Series
- ZN428E-8 Commercial temperature range 0°C to +70°C
- ZN428J-8 Military temperature range -55°C to +125°C

GENERAL DESCRIPTION

The ZN428 is a Monolithic 8 bit D to A converter with input latches to facilitate updating from a data bus. The latch is transparent when Enable is LOW and the data is held when Enable is taken HIGH. The ZN428 also contains a 2.5 volt reference the use of which is pin optional to retain flexibility. An external fixed or varying reference may therefore be substituted.

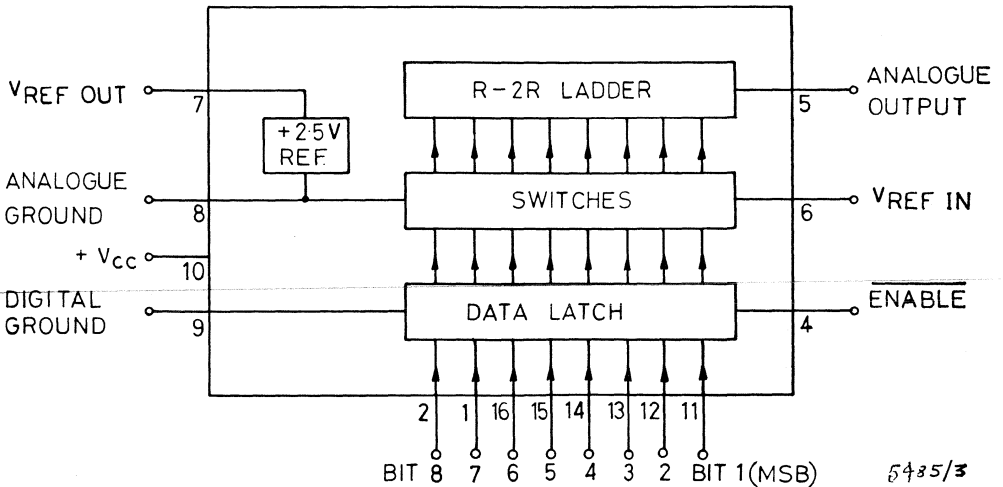

Fig. 1 SYSTEM DIAGRAM

ZN428E-8/J-8

ABSOLUTE MAXIMUM RATINGS

Supply voltage V_{CC}	+7.0 volts
Max. voltage, logic and V_{REF} input	+ V_{CC}
Operating temperature range	0°C to +70°C (ZN428E-8) -55°C to +125°C (ZN428J-8)
Storage temperature range	-55°C to +125°C
Analogue Ground to Digital Ground	±200 mV

ELECTRICAL CHARACTERISTICS ($V_{CC} = +5$ volts, $T_{amb} = 25^\circ\text{C}$ unless otherwise specified).

Parameter	Min.	Typ.	Max.	Units	Conditions
Internal Voltage Reference					
Output voltage	2.475	2.550	2.625	volts	} $R_{REF} = 390\Omega$ $C_{REF} = 1\mu\text{F}$
Slope resistance		0.5	2	Ω	
V_{REFOUT} T.C.		50		ppm/°C	
Reference current	4		15	mA	Note 1
D to A Converter					
Linearity error			±0.5	LSB	$2.0\text{V} \leq V_{REFIN} \leq 3.0\text{V}$
Differential non-linearity		±0.5		LSB	
Linearity error T.C.		±3		ppm/°C	
Differential non-linearity T.C.		±6		ppm/°C	
Offset voltage		2	5	mV	All bits OFF
Offset voltage T.C.		±6		$\mu\text{V}/^\circ\text{C}$	
Full scale output	2.545	2.550	2.555		} External reference $V_{REFIN} = 2.560$ volts, all bits ON
Full scale output T.C.		2		ppm/°C	
Analogue output resistance		4		k Ω	
External reference voltage	0		3.0	volts	
Settling time to 0.5 LSB		800		ns	1 LSB Major Transition (Note 2) All bits ON to OFF or OFF to ON (Note 2)
		1.25		μs	
Operating temperature range:					
ZN428E-8	0		70	C	
ZN428J-8	-55		125	C	
Supply voltage (V_{CC})	4.5	5.0	5.5	volts	

Note 1 See REFERENCE

Note 2 $R_L = 10\text{M}\Omega$, $C_L = 10\text{pF}$.

ELECTRICAL CHARACTERISTICS (continued)

	Min.	Typ.	Max.	Units	Conditions
Supply current		20	30	mA	Note 3
Power consumption		100		mW	
Logic (over specified operating temperature range)					
High level input voltage	2.0			V	
Low level input voltage			0.8	V	
High level input current			60	μ A	$V_{IN} = 5.5V$ $V_{CC} = \text{Max.}$
			20	μ A	$V_{IN} = 2.4V$ $V_{CC} = \text{Max.}$
Low level input current			-5	μ A	$V_{IN} = 0.4V$ $V_{CC} = \text{Max.}$
Input Clamp Diode Voltage		-1.5		V	$I_{IN} = -8 \text{ mA}$
Enable pulse width	100			ns	
Data set-up time	150			ns	Note 4
Data hold time	10			ns	Note 5

Note 3 All inputs HIGH ($V_{IH} = 3.5$ volts).

Note 4 Set up time before $\overline{\text{Enable}}$ goes high.

Note 5 Hold time after $\overline{\text{Enable}}$ goes high.

D TO A CONVERTER

The converter is of the voltage switching type and uses an R-2R ladder network as shown in Fig. 2. Each 2R element is connected to 0V or $V_{REF IN}$ by transistor voltage switches specially designed for low offset voltage (<1 millivolt). A binary weighted voltage is produced at the output of the R-2R ladder.

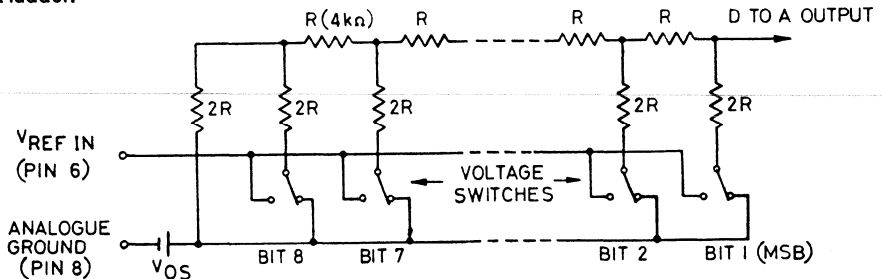

Fig. 2. The R-2R Ladder Network

ZN428E-8/J-8

$$\text{Analogue Output} = \frac{n}{256} (V_{\text{REF IN}} - V_{\text{OS}}) + V_{\text{OS}}$$

where n is the digital input to the D to A from the data latch.

V_{OS} is a small offset voltage produced by the D to A switch currents flowing through the package lead resistance. The value of V_{OS} is typically 1 mV. This offset will normally be removed by the setting up procedure (see APPLICATIONS section) and because the offset temperature coefficient is low ($\pm 6 \mu\text{V}/^\circ\text{C}$) the effect on accuracy is negligible.

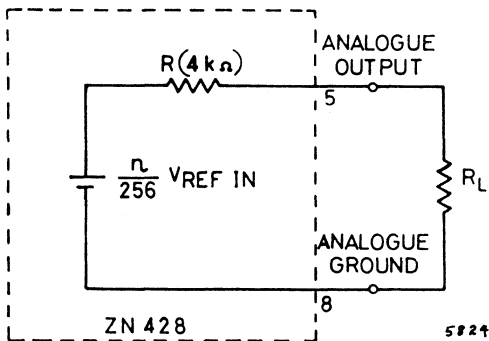

Fig. 3. Analogue Output Equivalent Circuit

Fig. 3 shows an equivalent circuit of the output (ignoring V_{OS}). The output resistance R has a temperature coefficient of $+0.2\%$ per $^\circ\text{C}$.

The gain drift due to this is $\frac{0.2R}{R+R_L}$ % per $^\circ\text{C}$

R_L should be chosen to be as large as possible to make the gain drift small. As an example if $R_L = 400 \text{ k}\Omega$ then the gain drift due to the T.C. of R for a 100°C change in ambient temperature will be less than 0.2% . Alternatively the ZN428 can be buffered by an amplifier (see APPLICATIONS section).

REFERENCE

(a) Internal Reference

The internal reference is an active band gap circuit which is equivalent to a 2.5 volt Zener diode with a very low slope impedance (Fig. 4). A resistor (R_{REF}), should be connected between $+V_{\text{CC}}$ (pin 10) and pin 7. The recommended value of 390Ω will supply a nominal reference current of $(5.0-2.5)/0.39 = 6.4 \text{ mA}$. A stabilising/decoupling capacitor, $C_{\text{REF}} = 1 \mu\text{F}$ is required between pins 7 and 8 for internal reference operation, $V_{\text{REF OUT}}$ (pin 7) being connected to $V_{\text{REF IN}}$ (pin 6).

Up to five ZN428s may be driven from one internal reference (there is no need to reduce R_{REF}) This useful feature saves power and gives excellent gain tracking between the converters.

(b) External Reference

If required an external reference voltage may be connected to $V_{\text{REF IN}}$. The slope resistance of such a reference source should be less than $\frac{2.5}{n} \Omega$, where n is the number of converters supplied.

$V_{\text{REF IN}}$ can be varied from 0 to $+3$ volts for ratiometric operation. The ZN428 is guaranteed monotonic for $V_{\text{REF IN}}$ above 2 volts.

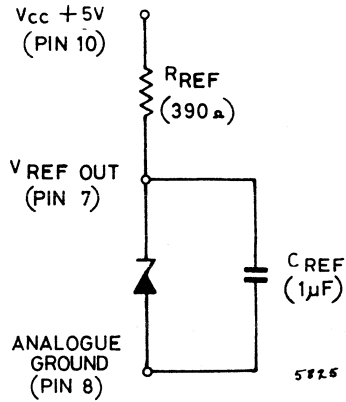

Fig. 4. Internal Voltage Reference

LOGIC

Input coding is binary for unipolar operation and offset binary for bipolar operation. When the Enable input is low the data inputs drive the D to A directly. When Enable goes high the input data word is held in the data latch.

The equivalent circuit for the data and clock inputs is shown in Fig. 5.

The ZN428 is provided with separate analogue and digital ground connections. The circuit will operate correctly with as much as ± 200 mV between the two grounds.

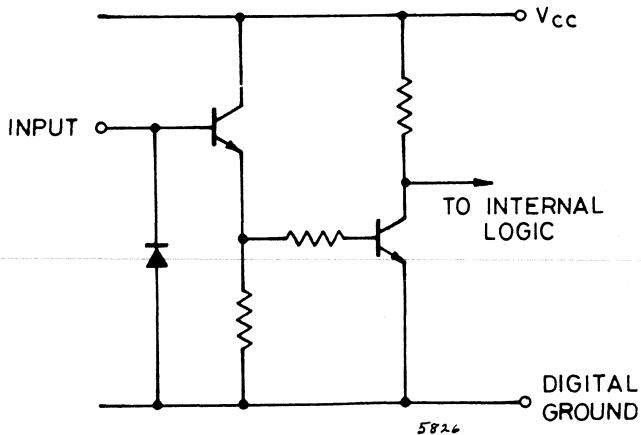

Fig. 5. Equivalent Circuit of All Inputs

ZN428E-8/J-8

APPLICATIONS

(1) Unipolar D to A Converter

The nominal output range of the ZN428 is 0 to $V_{REF IN}$ through a $4\text{ k}\Omega$ resistance. Other output ranges can readily be obtained by using an external amplifier.

The general scheme (Fig. 6) is suitable for amplifiers with input bias currents less than $1.5\text{ }\mu\text{A}$.

The resulting full scale range is given by

$$V_{OUT FS} = \left(1 + \frac{R_1}{R_2}\right) V_{REF IN} = G \cdot V_{REF IN}$$

The impedance at the inverting input is $R_1//R_2$ and for low drift with temperature this parallel combination should be equal to the ladder resistance ($4\text{ k}\Omega$). The required nominal values of R_1 and R_2 are given by $R_1 = 4G\text{ k}\Omega$ and $R_2 = 4G/(G-1)\text{ k}\Omega$.

Using these relationships a table of nominal resistance values for R_1 and R_2 can be constructed for $V_{REF IN} = 2.5\text{ volts}$.

Output Range	G	R_1	R_2
+5V	2	$8\text{ k}\Omega$	$8\text{ k}\Omega$
+10V	4	$16\text{ k}\Omega$	$5.33\text{ k}\Omega$

For gain setting R_1 is adjusted about its nominal value. Practical circuit realisations (including amplifier stabilising components) for +5V and +10V output ranges are given in Fig. 7. Settling time for a major transition is $1.5\text{ }\mu\text{s}$ typical.

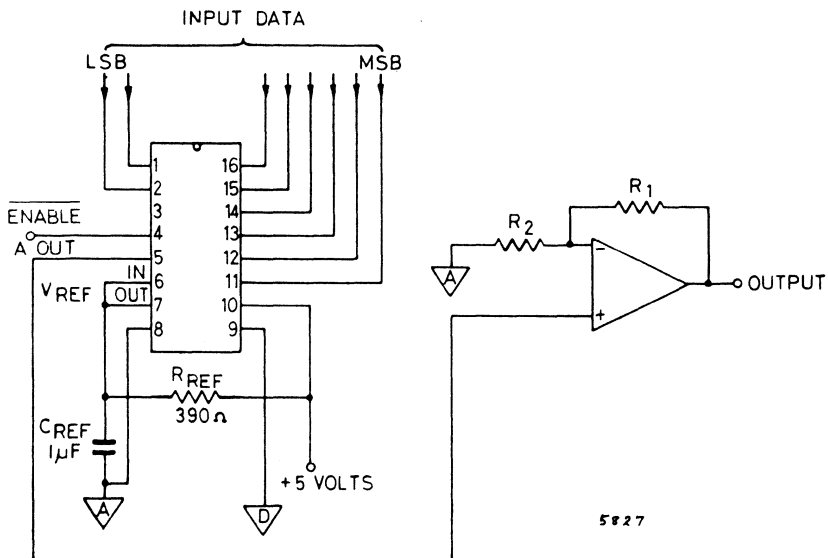

Fig. 6. Unipolar operation – Basic Circuit

ZN428E-8/J-8

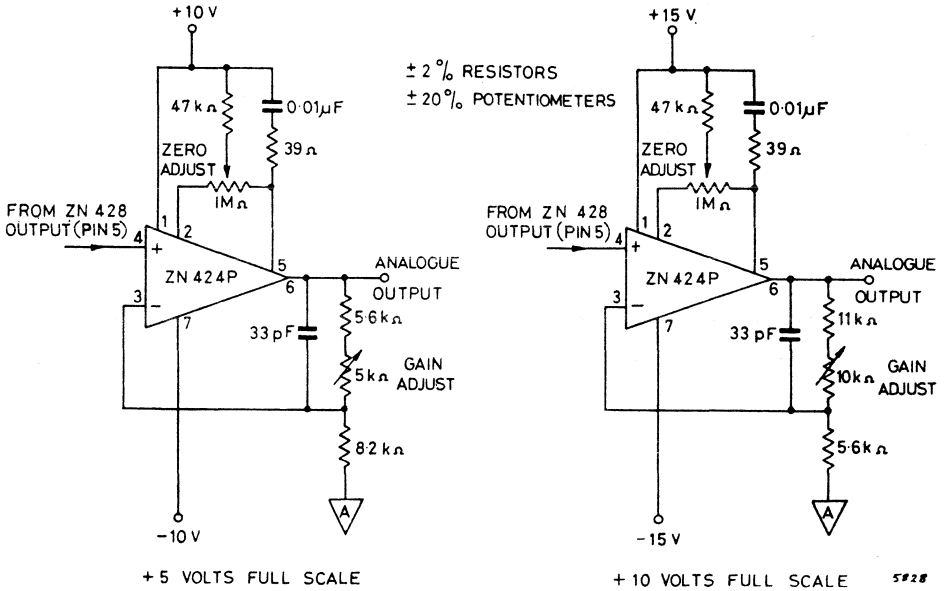

Fig. 7. Unipolar Operation – Component Values

UNIPOLAR ADJUSTMENT PROCEDURE

- (i) Set all bits to OFF (low) with $\bar{\text{Enable}}$ low and adjust zero until $V_{\text{OUT}} = 0.0000\text{V}$.
- (ii) Set all bits ON (high) and adjust gain until $V_{\text{OUT}} = \text{FS} - 1 \text{LSB}$.

UNIPOLAR SETTING UP POINTS

Output Range, +FS	LSB	FS - 1LSB
+5V	19.5 mV	4.9805V
+10V	39.1 mV	9.9609V

$$1\text{LSB} = \frac{\text{FS}}{256}$$

UNIPOLAR LOGIC CODING

Input Code (Binary)	Analogue Output (Nominal value)
11111111	FS - 1LSB
11111110	FS - 2LSB
11000000	$\frac{1}{2}$ FS
10000001	$\frac{1}{2}$ FS + 1LSB
10000000	$\frac{1}{2}$ FS
01111111	$\frac{1}{2}$ FS - 1LSB
01000000	$\frac{1}{2}$ FS
00000001	1LSB
00000000	0

ZN428E-8/J-8

(2) Bipolar D to A Converter

For bipolar operation the output from the ZN428 is offset by half full scale by connecting a resistor R_3 between $V_{REF IN}$ and the inverting input of the buffer amplifier (Fig. 8).

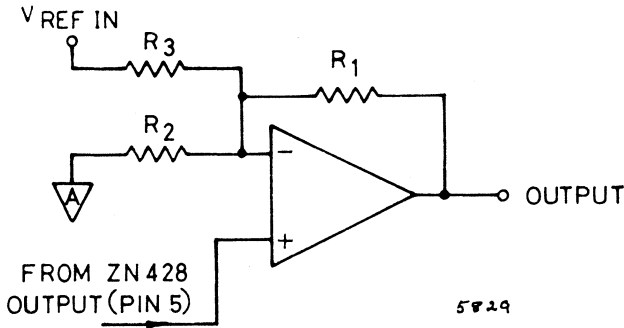

Fig. 8. Bipolar Operation – Basic Circuit

When the digital input to the ZN428 is zero the analogue output is zero and the amplifier output should be $-Full\ scale$. An input of all ones to the D to A will give a ZN428 output of $V_{REF IN}$ and the amplifier output required is $+ Full\ scale$. Also, to match the ladder resistance the parallel combination of R_1 , R_2 and R_3 should be $4\ k\Omega$.

The nominal values of R_1 , R_2 and R_3 which meet these conditions are given by

$$R_1 = 8G\ k\Omega, R_2 = 8G/(G-1)\ k\Omega\ \text{and}\ R_3 = 8\ k\Omega$$

where the resultant output range is $\pm G V_{REF IN}$.

A bipolar output range of $\pm V_{REF IN}$ (which corresponds to the basic unipolar range 0 to $V_{REF IN}$) is obtained if $R_1 = R_3 = 8\ k\Omega$ and $R_2 = \infty$.

Assuming that $V_{REF IN} = 2.5\ volts$ the nominal values of resistors for $\pm 5V$ and $\pm 10V$ output ranges are given in the following table:

Output Range	G	R_1	R_2	R_3
$\pm 5V$	2	16 k Ω	16 k Ω	8 k Ω
$\pm 10V$	4	32 k Ω	10.66 k Ω	8 k Ω

Minus full scale (offset) is set by adjusting R_1 about its nominal value relative to R_3 . Plus full scale (gain) is set by adjusting R_2 relative to R_1 .

Practical circuit realisations are given in Fig. 9. Note that in the $\pm 5V$ case R_3 has been chosen as 7.5 k Ω (instead of 8.2 k Ω) to get a more symmetrical range of adjustment using standard potentiometers. Settling time for a major transition is 1.5 μs typical.

ZN428E-8/J-8

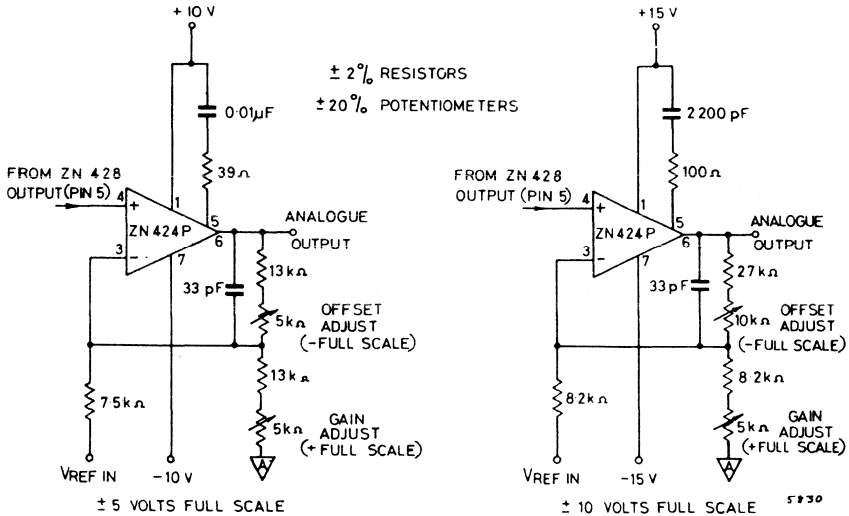

Fig. 9. Bipolar Operation – Component Values

Bipolar Adjustment Procedure

- (1) Set all bits to OFF (low) with $\overline{\text{Enable}}$ low and adjust offset until the amplifier output reads -Full Scale.
- (2) Set all bits ON (high) and adjust gain until the amplifier output reads +(Full Scale - 1LSB).

BIPOLAR SETTING UP POINTS

Input Range, \pm FS	LSB	-FS	+(FS-1LSB)
± 5 V	39.1 mV	-5.0000V	+4.9609V
± 10 V	78.1 mV	-10.0000V	+9.9219V

$$1\text{LSB} = \frac{2\text{FS}}{256}$$

BIPOLAR LOGIC CODING

Input Code (Offset Binary)	Analogue Output (Nominal Value)
11111111	+(FS - 1LSB)
11111110	+(FS - 2LSB)
11000000	$+\frac{1}{2}$ FS
10000001	+1LSB
10000000	0
01111111	-1LSB
01000000	$-\frac{1}{2}$ FS
00000001	-(FS - 1LSB)
00000000	-FS

ZN428E-8/J-8

PIN CONNECTIONS

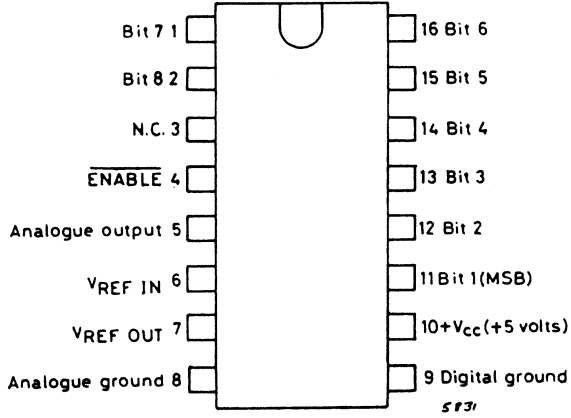

CHIP DIMENSIONS AND LAYOUT

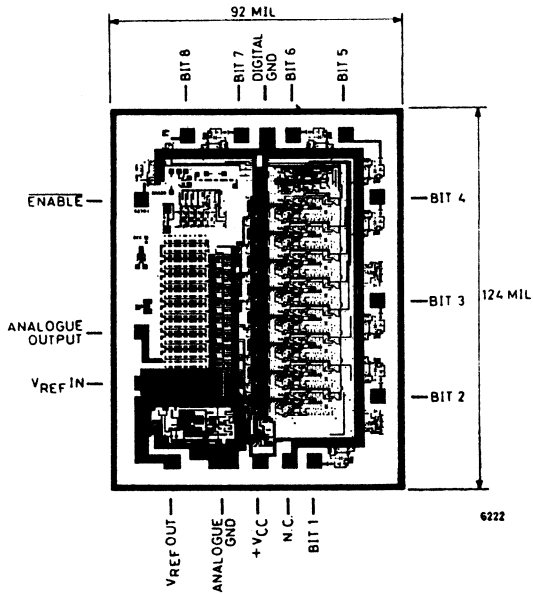

Low Cost 8 Bit Monolithic D to A Converter

FEATURES

- 8, 7 and 6-bit Accuracy
- ZN429E Series Commercial Temp. Range 0°C to +70°C
- ZN429J-8 Military Temp. Range -55°C to +125°C
- TTL and 5V CMOS Compatible
- Single +5V Supply
- Settling Time 1 μ sec. Typical
- Designed for low-cost applications

DESCRIPTION

The ZN429 is a monolithic 8-bit digital to analogue converter containing an R-2R ladder network of diffused resistors with precision bipolar switches.

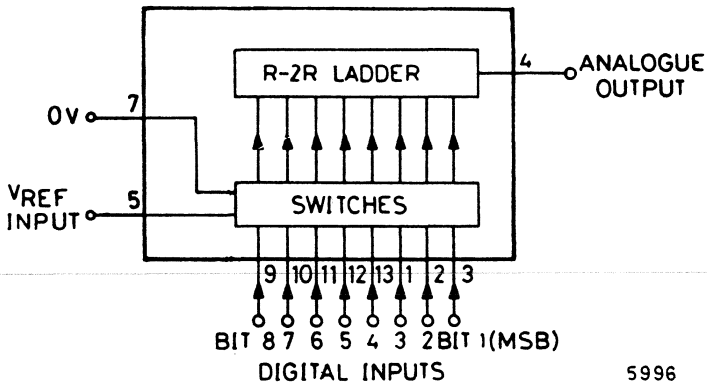

Fig. 1. System Diagram

ZN429 Series

INTRODUCTION

The ZN429 is an 8-bit digital to analogue converter. It contains an advanced design of R-2R ladder network and an array of precision bipolar switches on a single monolithic chip.

The special design of ladder network results in full 8-bit accuracy using normal diffused resistors. The converter is of the voltage switching type and uses an R-2R resistor ladder network as shown in Fig. 2.

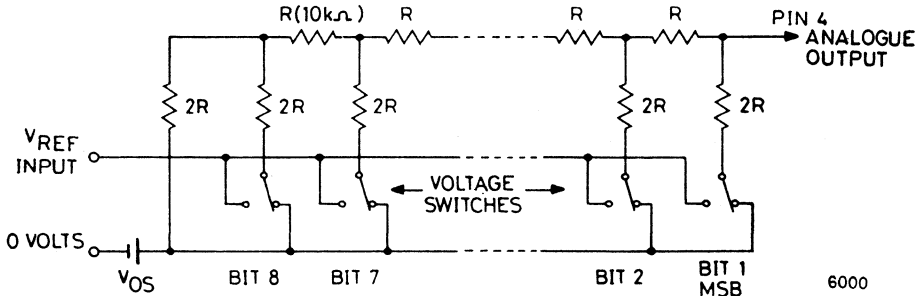

Fig. 2. The R-2R Ladder Network

Each 2R element is connected either to 0V or V_{REF} by transistor switches specially designed for low offset voltage (typically 1 millivolt).

Binary weighted voltages are produced at the output of the R-2R ladder, the value depending on the digital number applied to the bit inputs.

An external fixed or varying reference is required which should have a slope resistance less than 2 ohms.

Suggested external reference sources are the ZN404 or one of the ZN458 range. Each ZN404 is capable of supplying up to five ZN429 circuits and this is increased to ten for the ZN458 range.

ORDERING INFORMATION

Operating Temperature	8-bit accuracy	7-bit accuracy	6-bit accuracy	Package
0 to +70°C	ZN429E-8	ZN429E-7	ZN429E-6	Plastic
-55 to +125°C	ZN429J-8	—	—	Ceramic

ABSOLUTE MAXIMUM RATINGS

Supply voltage V_{CC}	+7.0 volts
Max. voltage, logic and V_{REF} inputs	+5.5 volts
Storage temperature range	-55 to +125°C

ZN429 Series

CHARACTERISTICS (at $T_{amb} = 25^{\circ}\text{C}$ and $V_{CC} = +5$ volts unless otherwise specified).

Parameter	Symbol	Min.	Typ.	Max.	Units	Conditions
Converter Resolution		8	—	—	bits	
Accuracy (useful resolution) ZN429J-8 } ZN429E-8 } ZN429E-7 } ZN429E-6 }		8 7 6	— — —	— — —	bits bits bits	V_{REF} input = 2.0 to 3.0 volts
Non-linearity		—	—	± 0.5	L.S.B.	<i>Note 1</i>
Differential non-linearity		—	± 0.5	—	L.S.B.	<i>Note 2</i>
Settling time to 0.5 L.S.B.		—	1.0	—	μs	1 L.S.B. step
Settling time to 0.5 L.S.B.		—	2.0	—	μs	All bits ON to OFF or OFF to ON
Offset voltage ZN429J-8 } ZN429E-8 } ZN429E-7 } ZN429E-6 }	V_{OS}	— —	5.0 3.0	8.0 5.0	mV mV	All bits OFF <i>Note 1</i>
V_{OS} temperature coefficient		—	5	—	$\mu\text{V}/^{\circ}\text{C}$	
Full scale output		2.545	2.550	2.555	volts	All bits ON Ext. $V_{REF} = 2.560\text{V}$
Full scale temp. coefficient		—	3	—	ppm/ $^{\circ}\text{C}$	Ext. $V_{REF} = 2.560\text{V}$
Non-linearity temp. coeff.		—	7.5	—	ppm/ $^{\circ}\text{C}$	Relative to F.S.R.

Notes:

- The ZN429J-8 differs from the ZN429E-8 in the following respects :
 - For the ZN429J-8, the maximum linearity error may increase to $\pm 0.4\%$ FSR i.e. ± 1 LSB over the temperature ranges -55°C to 0°C and $+70^{\circ}\text{C}$ to $+125^{\circ}\text{C}$.
 - Offset voltage. The difference is due to package lead resistance. This offset will normally be removed by the setting up procedure, and because the offset temperature coefficient is low, the specified accuracy will be maintained.
- Monotonic over full temperature range at resolution appropriate to accuracy.

ZN429 Series

CHARACTERISTICS (continued)

Parameter	Symbol	Min.	Typ.	Max.	Units	Conditions
Analogue output resistance	R_o	—	10	—	k Ω	
External reference voltage		0	—	3.0	volts	
Supply voltage	V_{CC}	4.5	—	5.5	volts	
Supply current	I_s	—	5	9	mA	
High level input voltage	V_{IH}	2.0	—	—	volts	
Low level input voltage	V_{IL}	—	—	0.7	volts	
High level input current	I_{IH}	—	—	10	μ A	$V_{CC} = \text{max.},$ $V_I = 2.4V$
		—	—	100	μ A	$V_{CC} = \text{max.},$ $V_I = 5.5V$
Low level input current	I_{IL}	—	—	-0.18	mA	$V_{CC} = \text{max.},$ $V_I = 0.3V$

APPLICATIONS

1. 8-bit D to A Converter

The ZN429 gives an analogue voltage output directly from pin 4 therefore the usual current to voltage converting amplifier is not required. The output voltage drift, due to the temperature coefficient of the Analogue Output Resistance R_o , will be less than 0.004% per °C (or 1 L.S.B./100°C) if R_L is chosen to be ≥ 650 k Ω

In order to remove the offset voltage and to calibrate the converter a buffer amplifier is necessary. Fig. 3 shows a typical scheme using the internal reference voltage. To minimise temperature drift in this and similar applications the source resistance to the inverting input of the operational amplifier should be approximately 6 k Ω . The calibration procedure is as follows:

- i.* Set all bits to OFF (low) and adjust R_2 until $V_{out} = 0.000V$.
- ii.* Set all bits to ON (high) and adjust R_1 until $V_{out} = \text{Nominal full scale reading} - 1 \text{ L.S.B.}$
- iii.* Repeat *i.* and *ii.*

e.g. Set F.S.R. to +3.840 volts - 1 L.S.B.
= 3.825 volts

$$(1 \text{ L.S.B.} = \frac{3.84}{256} = 15.0 \text{ millivolts})$$

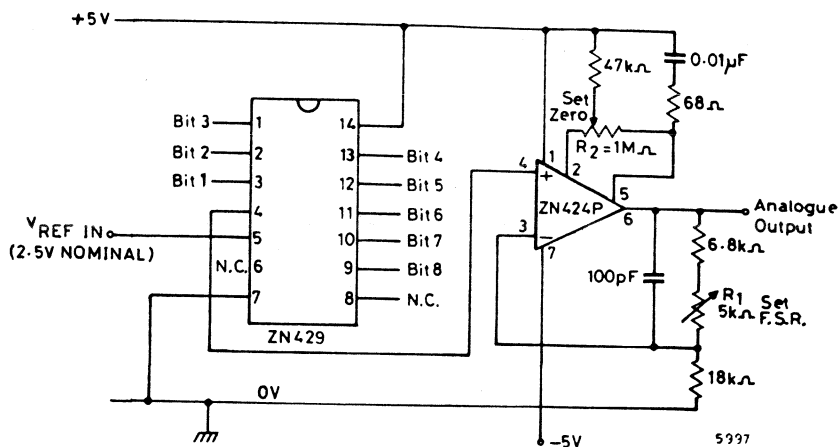

Fig. 3. 8-bit Digital to Analogue Converter

Alternative Output Buffer using the ZLD741

The following circuit, employing the ZLD741 operational amplifier, may be used as the output buffer (Fig. 3).

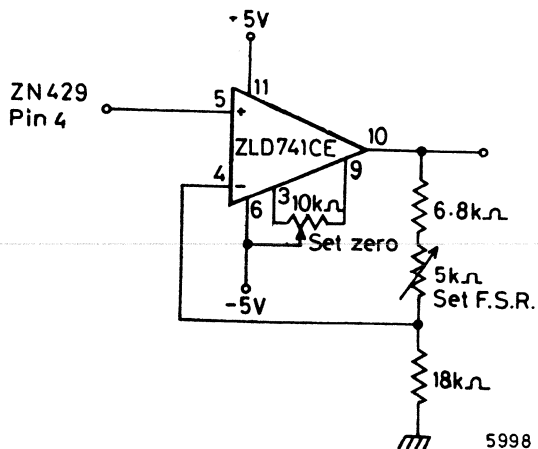
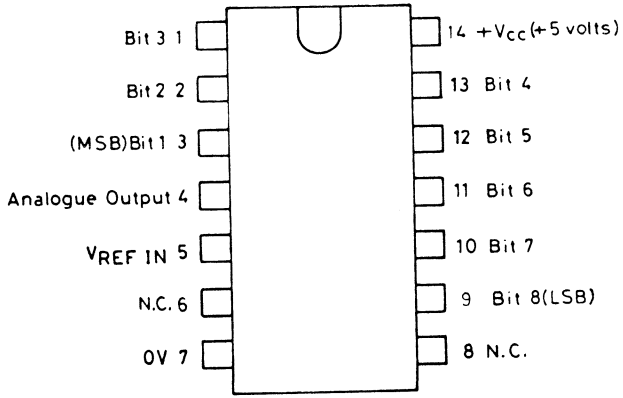

Fig. 4. The ZLD741 as Output Buffer

ZN429 Series

PIN CONNECTIONS



5999

CHIP DIMENSIONS AND LAYOUT

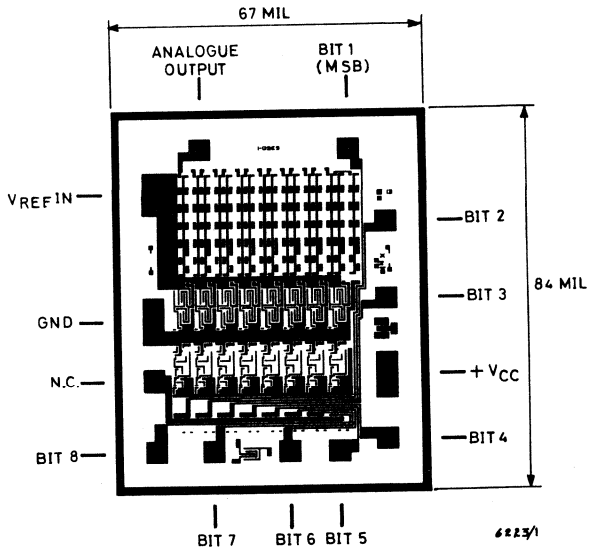

6223/1

Low Cost 4 Bit D to A Converter

PRODUCT NUMBER: ZN434

FEATURES

- 4 bit resolution
- ¼ LSB linearity
- Voltage output
- 300ns settling time
- TTL and CMOS compatible
- Single + 5V supply
- On-chip $\frac{V_{CC}}{2}$ reference
- 0°C to +70°C or -40°C to +85°C temperature range.

DESCRIPTION

The ZN 434 is a 4-bit DAC containing an R-2R ladder network of diffused resistors and precision bipolar switches. An on-chip reference amplifier and attenuator provide a reference voltage of $\frac{V_{CC}}{2}$, allowing the IC to function with no external components.

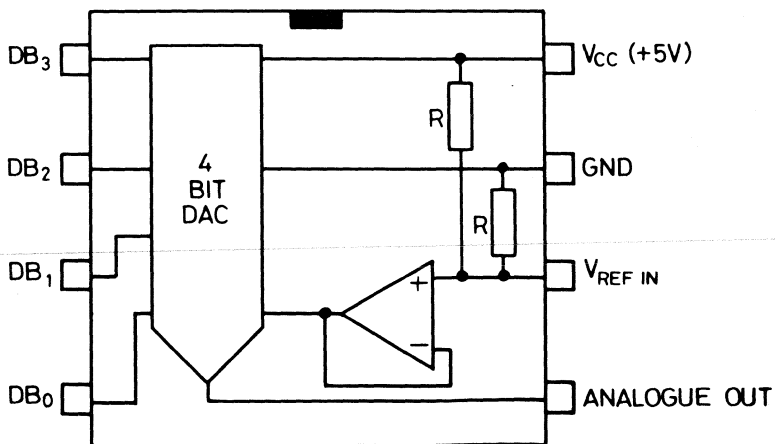

6566

ZN 434 SYSTEM DIAGRAM

ZN434

ABSOLUTE MAXIMUM RATINGS

Supply Voltage V_{CC}	+7.0 volts
Logic and V_{REF} inputs	0 to V_{CC}
						Min	Max
Operating Temperature (ZN 434E)	0°C	+70°C
(ZN 434BE)	-40°C	+85°C
Storage Temperature	-55°C	+125°C

ELECTRICAL CHARACTERISTICS ($V_{CC} = +5V$, $T_{amb} = 25^\circ C$ unless otherwise stated)

Parameter	Min.	Typ.	Max.	Units	Conditions	
D to A Converter Resolution	4	—	—	Bits	$1.5V < V_{REF\ in} < 3V$	
Linearity error	—	—	± 0.25	LSB		
Differential Linearity error	—	—	± 0.25	LSB		
Linearity error tempco	—	± 3	—	ppm/°C		
Differential linearity error tempco	—	± 6	—	ppm/°C		
Zero error	—	3.0	5.0	mV		
Zero error tempco	—	+6	—	$\mu V/^\circ C$		
Full-scale output (V_{CC} as reference)	2.235	2.345	2.456	volts	$1.5V < V_{REF\ in} < 3V$	
Full-scale output (External reference)	0.922	0.938	0.954	$V_{ref\ in}$		
Full scale tempco	—	± 3	—	ppm/°C		
Analogue output resistance	1.75	2.5	3.25	k		
Analogue output capacitance	—	15	—	pF		
Settling time to 0.5 LSB	—	200	300	ns		Code transition 0000 or 1111 1111 0000 1 LSB step
	—	100	150	ns		
Supply voltage	+4.5	+5	+5.5	V		
Supply current	—	10	15	mA		

Parameter	Min.	Typ.	Max.	Units	Conditions
On chip reference amplifier					
Output voltage	$\frac{V_{CC} \times 0.97}{2}$	$\frac{V_{CC}}{2}$	$\frac{V_{CC} \times 1.03}{2}$		
Input current	—	1	—	μA	
Offset voltage	—	± 10	—	mV	
Input resistance	9	18	27	k	
Logic Inputs					
High level input voltage V_{IH}	2.0	—	—	V	
Low level input voltage V_{IL}	—	—	0.8	V	
High level input current I_{IH}	—	—	10	μA	$V_{CC} = 5.5\text{V}, V_I = 2.4\text{V}$
Low level input current I_{IL}	—	—	100	μA	$V_{CC} = V_I = 5.5\text{V}$
	—	—	180	μA	$V_{CC} = 5.5\text{V}, V_I = 0.3\text{V}$

CIRCUIT DESCRIPTION

D to A Converter

The ZN 434 is a 4 bit DAC consisting of an R-2R ladder of diffused resistors and precision bipolar switches designed for low offset voltage.

The ladder operates in the voltage switching mode and produces an output voltage $V_{out} = \frac{n}{16} (V_{REF IN} - V_{OS}) + V_{OS}$, where n is the digital code set at the bit inputs and V_{OS} is a small offset voltage caused by the supply current flowing through the lead resistance of the ground pin.

On-chip Reference Amplifier

The ZN 434 contains a reference amplifier and attenuator that provide a reference voltage of nominally $\frac{V_{CC}}{2}$ without any external components. Taking into account the attenuator error, input current and offset voltage of the amplifier and gain error of the DAC the full-scale output will be within $\pm \frac{1}{2}$ LSB of the nominal value of $0.369 \times V_{CC}$.

By maintaining an accurate and stable supply voltage the ZN 434 may thus be used without an external reference. Where several ZN 434s are used in a system the V_{REF} inputs may be joined together to improve V_{REF} matching.

If a reference voltage other than $\frac{V_{CC}}{2}$ is required then the on-chip attenuator may be overridden, either by connecting a lower resistance attenuator in parallel or by using an active reference such as a bandgap reference source.

8-Bit Multifunction Data Converter
ADVANCE PRODUCT INFORMATION
FEATURES

- Multimode device operates as:
 - DAC
 - ADC
 - Tracking ADC
 - Voltage to Frequency Converter
 - Ramp and Sawtooth Generator
 - Nonlinear Waveform Generator
 - Voltage—Controlled Oscillator
 - Track-and-Hold Circuit
- 8-bit Accuracy
- 800ns DAC Settling Time
- On-chip Up/down Counter
- On-chip Clock
- On-chip Voltage Reference
- Single +5V supply
- Commercial or Military Temperature Range.

DESCRIPTION

The ZN435 is a versatile, multifunction 8-bit data conversion system. A voltage-output DAC, 8 bit up/down counter, stable 2.5v bandgap reference and clock generator are contained on a single chip.

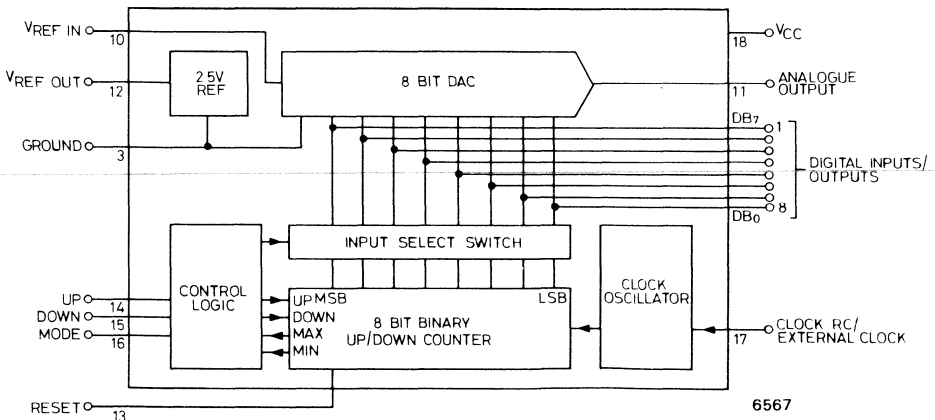
Fig. 1 SYSTEM DIAGRAM

ZN435

ABSOLUTE MAXIMUM RATINGS

Supply Voltage, V_{CC} +7.0 volts

Max. Voltage, Logic and V_{REF} inputs V_{CC}

Operating Temperature Range

TYPE	$T_{min} (^{\circ}C)$	$T_{max} (^{\circ}C)$
ZN435E	0	+70
ZN435J	-55	+125

Storage Temperature Range .. -55 $^{\circ}C$ to +125 $^{\circ}C$

ELECTRICAL CHARACTERISTICS ($V_{CC} = +5V$, $V_{REF} = 1.5-3.0V$, $T_{amb} = +25^{\circ}C$ unless otherwise stated).

Parameter	Min.	Typ.	Max.	Units	Conditions
D TO A CONVERTER					
Resolution	8	—	—	bits	T_{min} T_{amb} T_{max}
Linearity Error	—	± 0.25	± 0.5	L.S.B.	
Differential Linearity Error	—	± 0.25	± 1	L.S.B.	
Zero Error	—	3.0	5.0	mV	ZN435E All bits OFF
Settling time to 0.5LSB	—	5.0	10.0	mV	ZN435J
	—	500	—	ns	All bits OFF to ON or vice versa
Full-scale output	—	800	—	ns	All bits ON, $V_{REF} = 2.56V$
	2.545	2.550	2.555	V	
Output Resistance	—	4	—	k	Ext $V_{REF} = 2.56V$
Full-scale Temperature Coefficient	—	4	—	ppm/ $^{\circ}C$	
Reference Voltage	0	—	3	V	

Parameter	Min.	Typ.	Max.	Units	Conditions	
On-chip Voltage Reference						
Output Voltage	2.4	2.59	2.7	V	$R_{REF} = 390 \Omega$ $C_{REF} = 220n$	
Slope Resistance	—	2	4	Ω		
Temperature Coefficient of V_{REF}	—	50	—	ppm/ $^{\circ}C$		
Reference Current	4	—	15	mA		
Counter (with external clock)						
High Level Threshold Voltage V_{T+}	—	—	2.3	V	Device to Device using same R&C	
Low Level Threshold Voltage V_{T-}	1.7	—	—	V		
Maximum Clock Frequency	1	1.5	—	MHz		
On-chip Clock						
Maximum Frequency	500	—	—	KHz		
Clock Frequency Tempco	—	100	—	ppm/ $^{\circ}C$		
Clock Frequency Spread	—	—	1	%		
Clock Resistor	3	—	100	k		
Clock Capacitor	100	—	—	pF		
High Level Threshold Voltage V_{T+}	—	4.6	—	V		
Low Level Threshold Voltage V_{T-}	—	1.5	—	V		
Supply Rejection	—	0.8	—	%/V		
Logic Circuits						
BIT INPUTS						
High Level Input Voltage V_{IH}	2.0	—	—	V	$V_{IN} = 2.4V$ $V_{IN} = 0.4V$	
Low Level Input Voltage V_{IL}	—	—	0.8	V		
High Level Input Current I_{IH}	—	—	—100	μA		
Low Level Input Current I_{IL}	—	—	—220	μA		
BIT OUTPUTS						
High Level Output Voltage V_{OH}	—	5.0	—		No Load	
Low Level Output Voltage V_{OL}	—	0.1	—			
High Level Output Current I_{OH}	125	—	—	μA	$V_{OUT} = 2.4V$	
Low Level Output Current I_{OL}	—3.0	—	—	mA	$V_{OUT} = 0.4V$	

ZN435

Parameter	Min.	Typ.	Max.	Units	Conditions
CONTROL INPUTS					
High Level Input Voltage V_{IH}	2	—	—	V	$V_{IN} = 2.4V$ $V_{IN} = 0.4V$
Low Level Input Voltage V_{IL}	—	—	0.8	V	
High Level Input Current I_{IH}	—	—	—25	μA	
Low Level Input Current I_{IL}	—	—	—95	μA	
Reset Pulse Width	200	—	ns		
Power Supply					
Supply Voltage	4.5	5	5.5	V	$V_{CC} = 5.5V$
Supply Current	—	35	45	mA	

GENERAL CIRCUIT OPERATION

The ZN435 incorporates an 8-bit DAC based on a voltage switching R-2R ladder network. The reference voltage for this ladder may be derived from the on-chip precision bandgap reference, or an external reference voltage may be supplied.

The ZN435 also contains an 8-bit up/down counter and control logic. The DAC may receive its digital input data from the counter, the counter outputs being simultaneously available at an 8-bit I/O port. Alternatively the counter outputs may be inhibited and the I/O port used to feed data direct to the DAC inputs.







An on-chip oscillator is provided to drive the clock input of the up-down counter. The on-chip clock may be overridden by an external clock signal.

UP/DOWN COUNTER AND CONTROL LOGIC

The counter is a high-speed, synchronous up/down type, whose operation is determined by four control pins. The functions of the UP, DOWN and RESET inputs are fairly self explanatory. the MODE input determines the behaviour of the counter at zero and full-scale. When the MODE input is high the counter will reset to zero if it is clocked past full-scale in the UP direction and will reset to 255 if it is clocked past zero in the DOWN direction. When the MODE input is low the counter will stop on reaching full-scale or zero.

The normally invalid state of UP and DOWN inputs low simultaneously is also utilised in the ZN435. With the MODE input high and UP and DOWN inputs low the counter will cycle up and down continuously, reversing at full-scale and zero. With all three control inputs low the counter outputs are disabled and the DAC inputs are accessible from the I/o port.

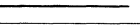
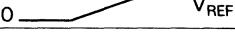
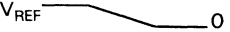
A truth table for the control inputs is given in Table 1.

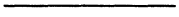
RESET	MODE	DOWN	UP	DIGITAL FUNCTION	ANALOGUE WAVEFORM
1	1	1	1	Counter Stopped.	
1	1	1	0	Count up continuously.	
1	1	0	1	Count down continuously.	
1	1	0	0	Count up, reverse at F.S., count down, reverse at zero.	
1	0	1	1	Counter Stopped.	
1	0	1	0	Count up, Stop at F.S.	
1	0	0	1	Count down, Stop at zero.	
X	0	0	0	DAC MODE, Counter output disabled. Counter can still be reset by taking reset input low.	
0	X	X	X	Counter reset. Does not affect analogue output in DAC MODE.	

ZN435

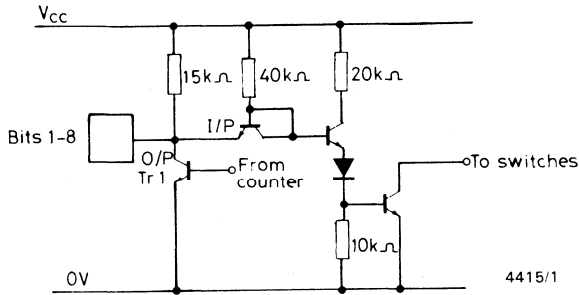

Fig. 2—BIT INPUTS/OUTPUTS

DATA PORT

One bit of the data port is shown in figure 2. The input/output pin is the junction of the counter output buffer and the DAC input buffer.

Normally the DAC is driven from the counter and the counter data is also available at the port. However, when the counter outputs are disabled the output transistors are turned off and the DAC inputs may be accessed from the data port.

The data port can drive or be driven from B-series CMOS and all TTL families.

CLOCK CIRCUIT

The on-chip clock circuit of the ZN435 is shown in figure 3.

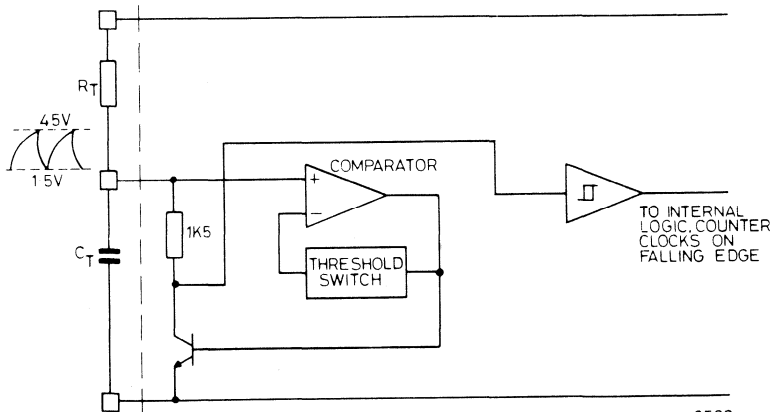

Fig. 3

The frequency of the clock is given by $f_{CLK} = \frac{1}{4R_T C_C}$ (Hz, ~, F)

Graphs of oscillator frequency versus resistor and capacitor values are given in figure 4.

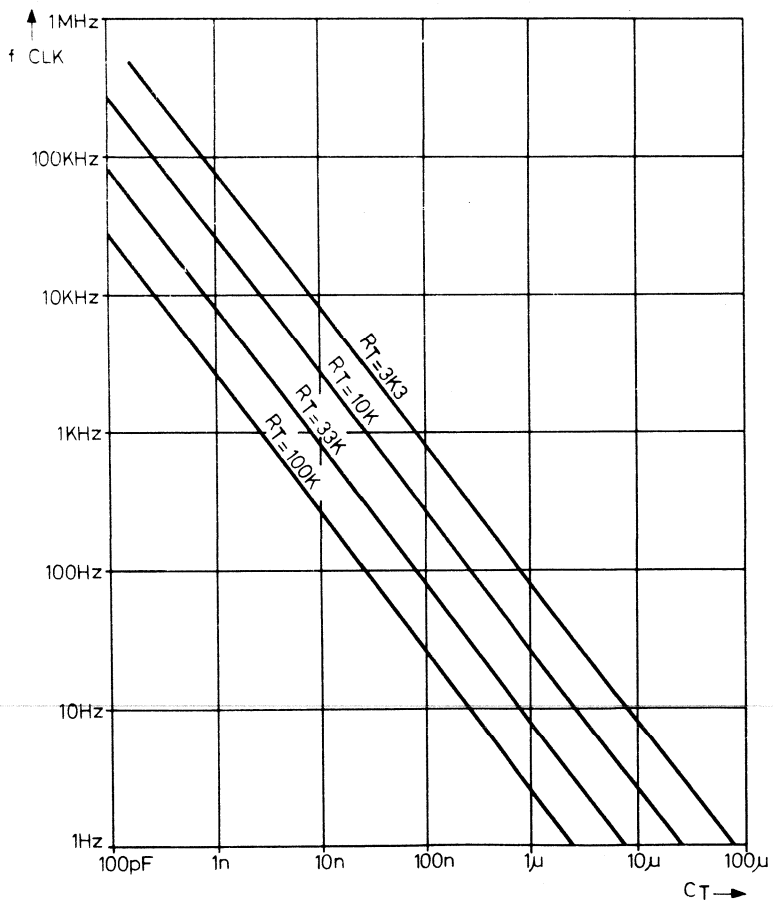

Fig. 4

6569

ZN435

The external capacitor C_T is charged via the external resistor R_T to the upper threshold of the comparator (about +4.5V with $V_{CC} = +5V$). The comparator turns on the discharge transistor to discharge C_T and switches its threshold to the lower value of about 1.5V. When the voltage on C_T has fallen to this level the comparator turns off the discharge transistor and the cycle repeats.

The clock can be overdriven direct from a TTL totem-pole output, as shown in figure 5a. If open collector or CMOS gates are used then their V_{OH} must be attenuated to below 4.5V, as shown in figures 5b and 5c. these thresholds the Schmitt trigger delivers clock pulses to the internal logic.

This slightly complicated arrangement has the advantage that the clock can be overdriven without turning on the discharge transistor, provided the drive voltage V_{OH} level does not exceed 4.5V.

The clock can be overdriven direct from a TTL totem-pole output, as shown in figure 5a. If open collector or CMOS gates are used then their V_{OH} must be attenuated to below 4.5V, as shown in figures 5b and 5c.

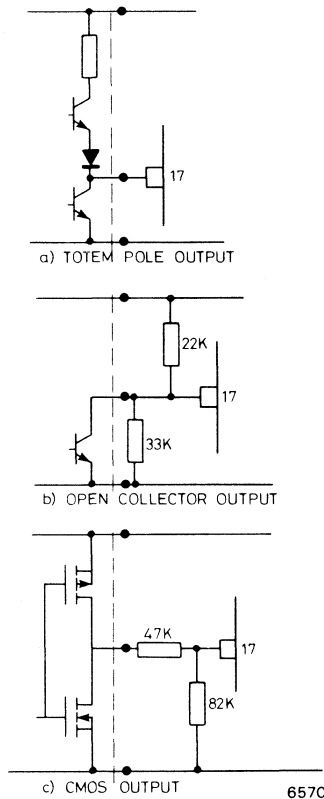

Fig. 5. OVERDRIVING THE CLOCK INPUT

ANALOGUE CIRCUITS

D TO A CONVERTER

The DAC is of the voltage switching type and uses an R-2R ladder network as shown in figure 6.

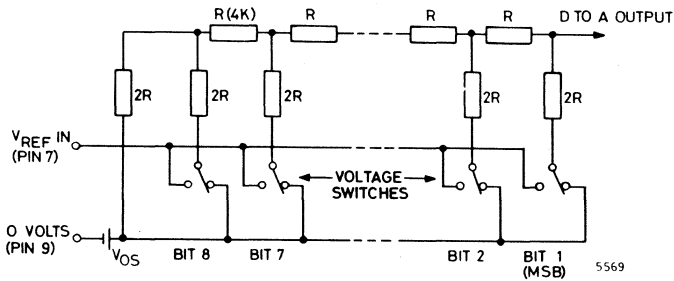

Fig. 6 R2-R LADDER NETWORK

Each 2R element is connected to either 0V or $V_{REF IN}$ by transistor voltage switches specially designed for low offset voltage ($\ll 1$ millivolt). A binary weighted voltage is produced at the output of the R-2R ladder.

$$V_{OUT} = \frac{n}{256} (V_{REF IN} - V_{OS}) + V_{OS}$$

where n is the digital input from the counter or data port.

V_{OS} is a small offset voltage that is produced by the device supply current flowing in the package lead resistance. The value of V_{OS} is typically 3mV for the ZN435E and 5mV for the ZN435J. This offset will normally be removed by the setting up procedure and since the offset temperature coefficient is small the zero drift will be small. The DAC output range can be considered to be 0 volts to $V_{REF IN}$ with an output resistance R (4k Ω).

REFERENCE

ON-CHIP REFERENCE

The internal reference is an active bandgap circuit which is equivalent to a 2.5V zener diode with a very low slope impedance (Fig. 7).

ZN435

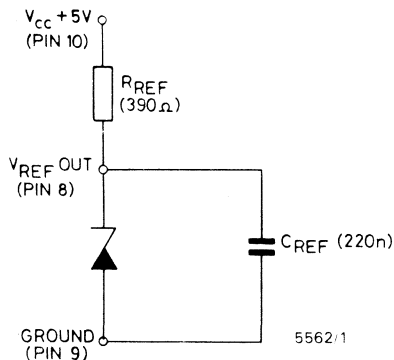

Fig. 7 INTERNAL VOLTAGE REFERENCE

An external resistor (R_{REF}) should be connected between pins 10 and 17 to bias up the on-chip reference, whilst a stabilising/decoupling capacitor (C_{REF}) is required between pins 8 and 9.

To use the internal reference $V_{REF OUT}$ (Pin 12) is connected to $V_{REF IN}$ (Pin 10).

The recommended reference resistor of 390Ω will supply a nominal reference current of 6.4mA which is sufficient to drive the reference inputs of up to five ZN435s. Where several ZN435s are used in a system this useful feature can save up to four resistors and capacitors as well as reducing power consumption and giving excellent gain tracking.

APPLICATIONS

The applications of the ZN435 are too many and varied to detail in this data sheet. However a few basic configurations are illustrated.

WAVEFORM GENERATOR

The circuit of a low-frequency waveform generator is illustrated in figure 8.

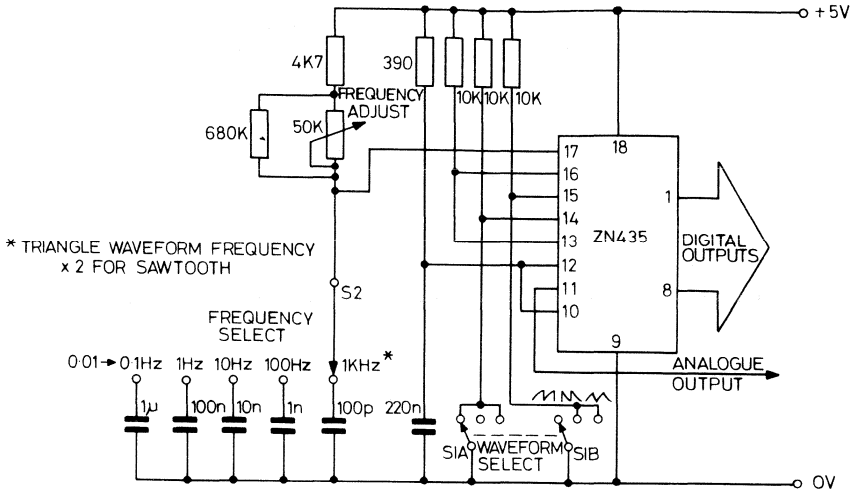

6571

This will produce stable, linear, sawtooth and triangle waveforms.

RAMP AND COMPARE A TO D CONVERTER

A simple ramp and compare A to D converter can be constructed using the ZN435 and an external comparator, as shown in figure 9.

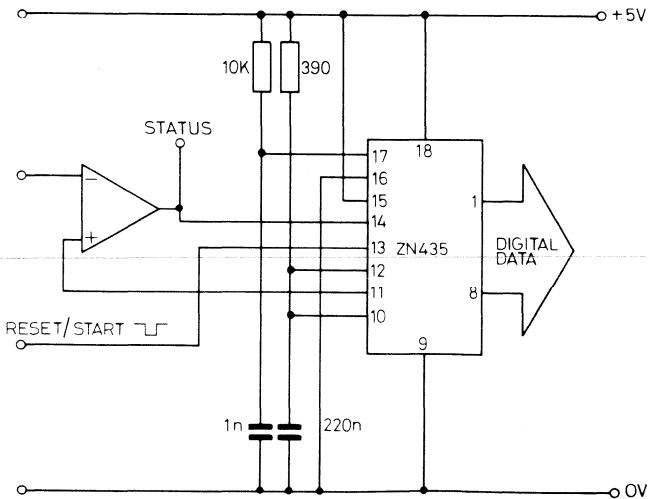

6572

ZN435

The counter is set to count up from zero, producing a positive-going ramp at the analogue output. When the ramp voltage exceeds the analogue input the comparator output will go high, inhibiting the clock and stopping the counter. The converter can be reset and re-started by applying a low-going pulse to the reset input.

The basic analogue input range is $0 - V_{REF}$, but other ranges can be accommodated by adding an attenuator to the comparator input. The comparator offset adjustment can be used for zero adjustment. Note that in this circuit the mode input is tied low to make the counter stop at full-scale. This prevents the counter cycling in the event of an overrange input.

TRACKING A TO D CONVERTER

The on-chip up-down counter allows the ZN435 to be configured very simply as a tracking A to D converter using an external comparator, as shown in figure 10.

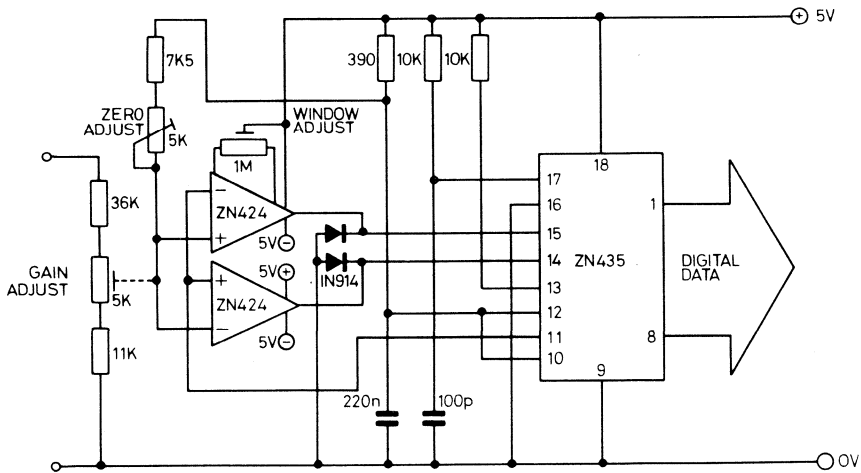

6573

Fig. 10 TRACKING ADC

ZN435

In this circuit two ZN424 op amps are used to make a window comparator. This has a deadband equal to one LSB of the DAC output (10mV), which is set by adjusting the offset of A1 until its threshold is 10mV above that of A2.

Whenever the analogue voltage is above the threshold of A1 the counter will count up so that the DAC output increases to follow the analogue voltage. Whenever the analogue voltage is below the threshold of A2 the counter will count down to make the DAC follow the analogue voltage. When the analogue voltage is between the two thresholds the outputs of A1 and A2 will be high and the counter will be stopped.

The circuit here has an analogue input range of $\pm 10V$. Other ranges may be accommodated by suitable choice of input resistors.

Note that in this circuit the mode input is tied low. This causes the counter to stop when full-scale or zero is reached, i.e. when the analogue input exceeds plus or minus full-scale. Without this feature the counter would simply cycle continuously.

PIN CONNECTIONS

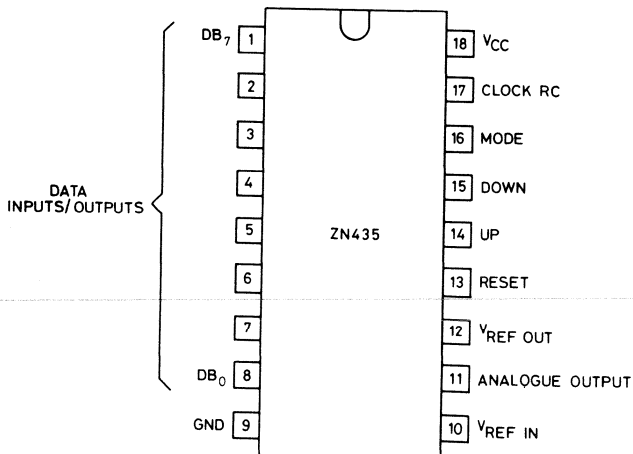

6574

ZN435



Low Cost 6 Bit Monolithic D to A Converter

FEATURES

- 6-bit Accuracy
- ZN436E Commercial Temp. Range 0°C to +70°C
- ZN436J Military Temp. Range -55°C to +125°C
- TTL and 5V CMOS Compatible
- Single +5V Supply
- Settling Time 1 μ sec. Typical
- Designed for low-cost applications

DESCRIPTION

The ZN436 is a monolithic 6-bit digital to analogue converter containing an R-2R ladder network of diffused resistors with precision bipolar switches.

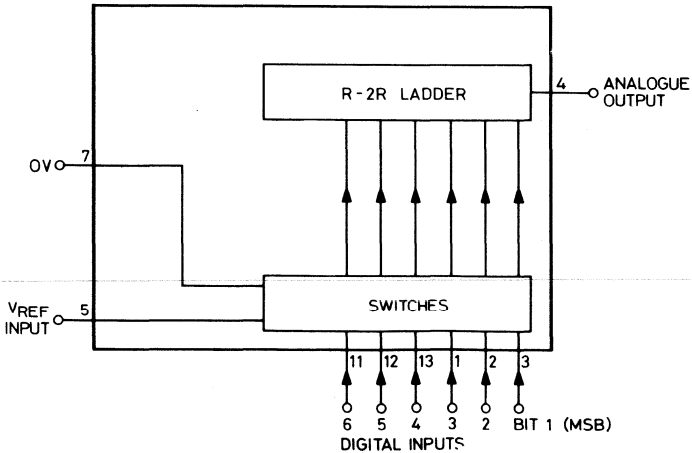

1990

Fig. 1. SYSTEM DIAGRAM

ZN436E/J

INTRODUCTION

The ZN436 is a 6-bit digital to analogue converter. It contains an advanced design of R-2R ladder network and an array of precision bipolar switches on a single monolithic chip.

The special design of ladder network results in full 6-bit accuracy using normal diffused resistors.

The converter is of the voltage switching type and uses an R-2R resistor ladder network as shown in Fig. 2.

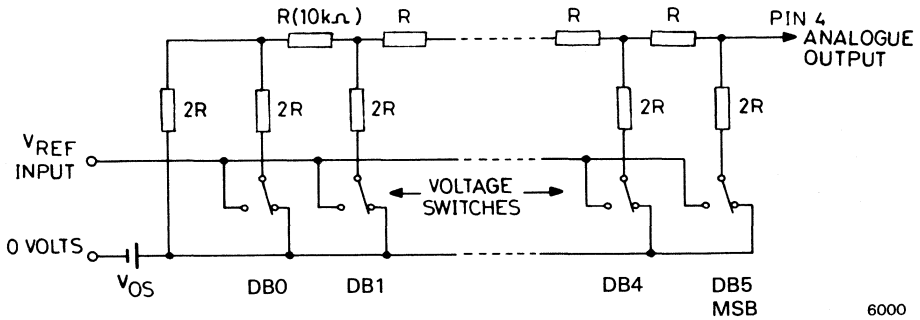

6000

Fig. 2 THE R-2R LADDER NETWORK

Each $2R$ element is connected either to $0V$ or V_{REF} by transistor switches specially designed for low offset voltage (typically 1 millivolt).

Binary weighted voltages are produced at the output of the R-2R ladder, the value depending on the digital number applied to the bit inputs.

An external fixed or varying reference is required which should have a slope resistance less than 2 ohms.

Suggested external reference sources are the ZN404 or one of the ZN458 range. Each ZN404 is capable of supplying up to five ZN436 circuits and this is increased to ten for the ZN458 range.

ORDERING INFORMATION

Operating Temperature	6-bit accuracy			Package
0 to +70°C	ZN436E			Plastic
-55 to +125°C	ZN436J			Ceramic

ABSOLUTE MAXIMUM RATINGS

Supply voltage V_{CC}	+7.0 volts
Max. voltage, logic and V_{REF} inputs	+5.5 volts
Storage temperature range	-55 to +125°C

CHARACTERISTICS (at $T_{amb} = 25^\circ\text{C}$ and $V_{CC} = +5$ volts unless otherwise specified).

Parameter	Symbol	Min.	Typ.	Max.	Units	Conditions
Converter Resolution			—	—	bits	
Accuracy (useful resolution) ZN436J		6	—	—	bits	V_{REF} input = 2.0 to 3.0 volts
ZN436E		6	—	—	bits	
Non-linearity		—	—	± 0.5	L.S.B.	<i>Note 1</i>
Differential non-linearity		—	± 0.5	—	L.S.B.	<i>Note 2</i>
Settling time to 0.5 L.S.B.		—	1.0	—	μs	1 L.S.B. step
Settling time of 0.5 L.S.B.		—	2.0	—	μs	All bits ON to OFF or OFF to ON
Offset voltage ZN436J	V_{OS}	—	5.0	8.0	mV	All bits OFF <i>Note 1</i>
ZN436E		—	3.0	5.0	mV	
V_{OS} temperature coefficient		—	5	—	$\mu\text{V}/^\circ\text{C}$	
Full scale output		2.510	2.520	2.530	volts	All bits ON Ext $V_{REF} = 2.560\text{V}$
Full scale temp. coefficient		—	3	—	ppm/ $^\circ\text{C}$	Ext. $V_{REF} = 2.560\text{V}$
Non-linearity temp. coeff.		—	7.5	—	ppm/ $^\circ\text{C}$	Relative to F.S.R.

ZN436E/J

CHARACTERISTICS (continued)

Parameter	Symbol	Min.	Typ.	Max.	Units	Conditions
Analogue output resistance	R_O	—	10	—	$k\Omega$	
External reference voltage		0	—	3.0	volts	
Supply voltage	V_{CC}	4.5	—	5.5	volts	
Supply current	I_S	—	5	9	mA	
High level input voltage	V_{IH}	2.0	—	—	volts	
Low level input voltage	V_{IL}	—	—	0.7	volts	
High level input current	V_{IH}	—	—	10	μA	$V_{CC} = \text{max.},$ $V_I = 2.4V$
		—	—	100	μA	$V_{CC} = \text{max.},$ $V_I = 5.5V$
Low level input current	I_{IL}	—	—	-0.18	mA	$V_{CC} = \text{max.},$ $V_I = 0.3V$

APPLICATIONS

1. 6-bit D to A Converter

The ZN436 gives an analogue voltage output directly from pin 4 therefore the usual current to voltage converting amplifier is not required. The output voltage drift, due to the temperature coefficient of the Analogue Output Resistance R_O , will be less than 0.004% per °C (or 1 L.S.B./100°C) if R_L is chosen to be $> 650k\Omega$.

In order to remove the offset voltage and to calibrate the converter a buffer amplifier is necessary. Fig. 3 shows a typical scheme using the internal reference voltage. To minimise temperature drift in this and similar applications the source resistance to the inverting input of the operational amplifier should be approximately $6k\Omega$. The calibration procedure is as follows:

- i. Set all bits to OFF (low) and adjust R_2 until $V_{out} = 0.000V$.
- ii. Set all bits to ON (high) and adjust R_1 until $V_{out} = \text{Nominal full scale reading} - 1 \text{ L.S.B.}$
- iii. Repeat i. and ii.

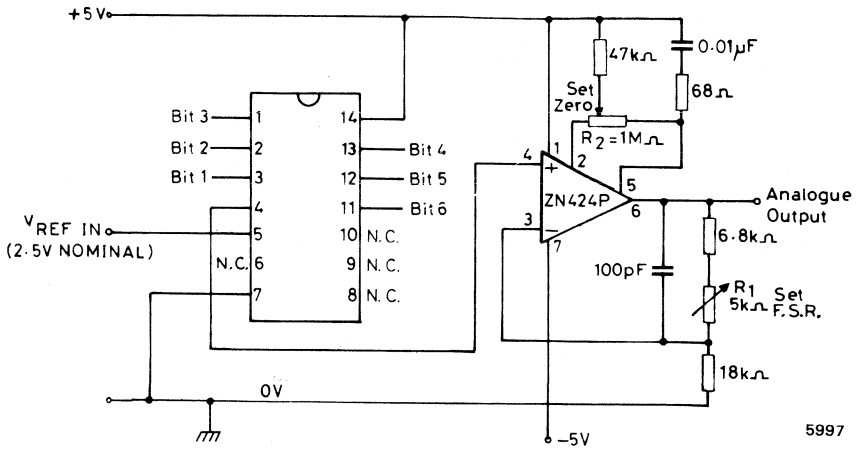

5997

Fig. 3 6-BIT DIGITAL TO ANALOGUE CONVERTER

Alternative Output Buffer using the ZLD741

The following circuit, employing the ZLD741 operational amplifier, may be used as the output buffer (Fig. 3).

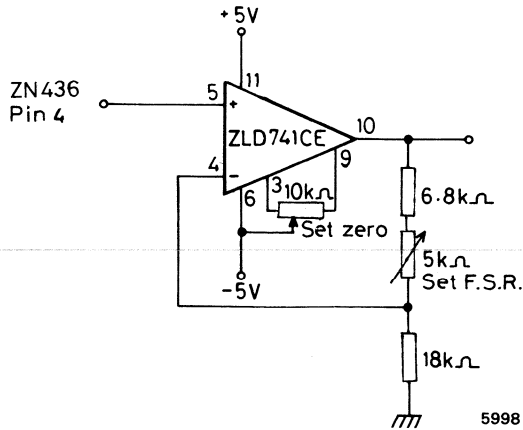

5998

Fig. 4 THE ZLD741 AS OUTPUT BUFFER

ZN436E/J

PIN CONNECTIONS

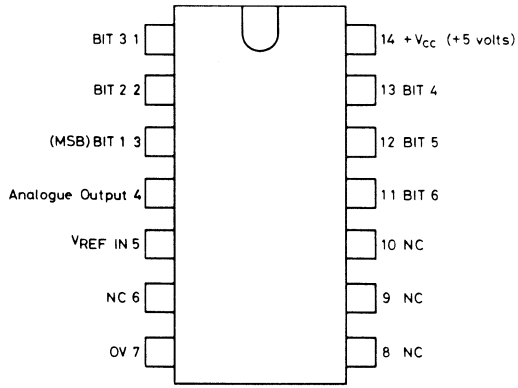

6596

2. Analogue-to-Digital Converters

Contents

	page
Selection Guide	2-3
Orientation	2-5
ZN 425, see D/A	
ZN 427	2-17
ZN 432	2-35
ZN 432E	2-45
ZN 433	2-53
ZN 435, see D/A	
ZN 440	2-63
ZN 447	2-75
ZN 448	2-75
ZN 449	2-75
ZN 450	2-97
ZNA 116	2-121
ZNA 216	2-135

PRODUCT SELECTION GUIDE A TO D CONVERTERS

TYPE	USEFUL RESOLUTION (BITS)	CONVERSION TIME (μ s)	CONVERSION METHOD	ON-CHIP REFERENCE	TEMPERATURE RANGE ($^{\circ}$ C)	FEATURES	PAGE
ZN425E Series	8-6	1000	Ramp and compare	+	0 to 70	Low cost dual purpose A/D-D/A converter	1-13
ZN425J	8	1000	Ramp and compare	+	-55 to +125	Low cost dual purpose A/D-D/A converter	1-13
ZN427E-8	8	10	Succ. Approx.	+	0 to 70	Microprocessor, TTL and CMOS compatible	2-17
ZN427-J8	8	10	Succ. Approx.	+	-55 to +125	Microprocessor, TTL and CMOS compatible	2-17
ZN432CJ Series	10-8	15	Succ. Approx.	+	0 to 70	TTL and CMOS compatible Parallel/serial Output,	2-35
ZN432J Series	10-8	15	Succ. Approx.	+	-55 to +125	TTL and CMOS compatible Parallel/serial Output,	2-35
ZN433CJ Series	10-8	$1(\Delta U_{IN}=1LSB)$	Tracking	+	0 to 70	TTL and CMOS compatible Parallel/serial Output,	2-53
ZN433J Series	10-8	$1(\Delta U_{IN}=1LSB)$	Tracking	+	-55 to +125	TTL and CMOS compatible Parallel/serial Output,	2-53
ZN435E	8	800	Ramp and compare	+	0 to 70	Dual purpose A/D-D/A converter (up/down counter)	1-47
ZN435J	8	800	Ramp and compare	+	-55 to +125	Dual purpose A/D-D/A converter (up/down counter)	1-47
ZN440J	6	0.06	Parallel (Flash)	-	0 to 70	Ultra fast monolithic Video A/D converter	2-63
ZN447-449E Series	8-6	9	Succ. Approx.	+	0 to 70	Clock generator, Microproc. TTL and CMOS compatible	2-75
ZN447-449J Series	8-6	9	Succ. Approx.	+	-55 to +125	Clock generator, Microproc. TTL and CMOS compatible	2-75
ZN450E, CJ	3 1/2 Digit BCD	250ms	Charge balancing	+	0 to 70	Single chip DVM for direct LCD drive	2-97
ZNA116E,J	3 1/2 Digit BCD	160ms	Dual Slope	-	0 to 70	DVM logic subsystem for LED MPX display	2-121
ZNA216,J	3 3/4 Digit BCD	160ms	Dual Slope	-	0 to 70	DVM logic subsystem for LED MPX display	2-135

2. ANALOGUE TO DIGITAL CONVERTERS

An analogue to digital Converter (ADC) is a device which converts an analogue input into a corresponding digital output code.

2.1 Ideal Output Characteristics

Assuming a unipolar input voltage and binary coded output, the transfer function of an ideal n-bit ADC is given by:

$$V_{FS} (B_1 \cdot 2^{-1} + B_2 \cdot 2^{-2} + \dots + B_n \cdot 2^{-n}) = V_{in} \pm \frac{1}{2} \text{LSB}$$

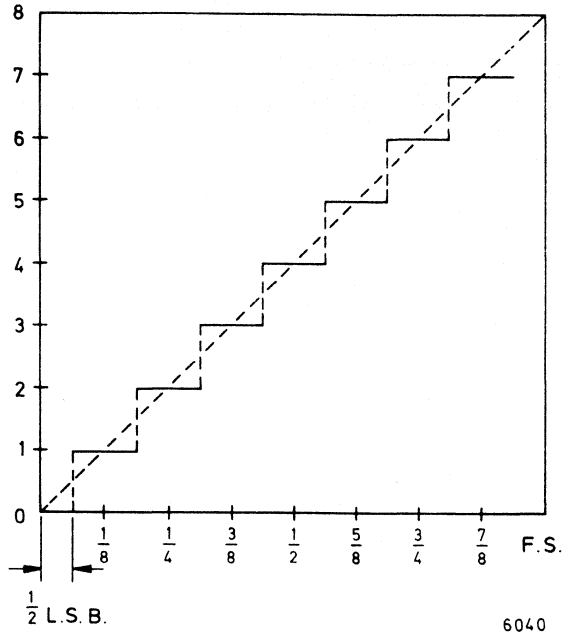

Fig. 9. Ideal 3-bit ADC Transfer Characteristic

The transfer function of an ideal 3-bit ADC is shown in figure 9. In this case there are 8 digital output codes corresponding to the 8 input codes of a DAC. However, unlike the analogue output of a DAC, the analogue input of an ADC can vary continuously, which means that each digital output code, with the exception of 0 and 7, exists over an analogue increment of 1 LSB. The zero of an ADC is usually trimmed so that the transitions between codes occur $\frac{1}{2}$ LSB on either side of the nominal analogue input for a particular code. For example, the nominal input for output code 2 is $\frac{1}{4} V_{FS}$. The transition from 1 to 2 occurs at $\frac{3}{16} V_{FS}$ and the transition from 2 to 3 occurs at $\frac{5}{16} V_{FS}$.

As with a DAC, an 'ideal' straight line may be drawn through the transfer characteristic of an ADC.

A to D Converters

2.2 Practical A to D Conversion Methods

There are many methods of performing an analogue to digital conversion. Although not all of these methods are used in the current range of Ferranti A-D converters, they are all, nonetheless, mentioned for the sake of completeness.

2.2.1 Parallel (Flash) Conversion

In an n-bit parallel converter (Fig. 10) a resistor ladder is used to generate $2^n - 1$ voltage levels from 1 LSB to $(2^n - 1) \times \text{LSB}$ which are fed to the reference inputs of $2^n - 1$ voltage comparators. The analogue input signal is fed to the second input of each comparator, and is thus compared simultaneously with each of the $2^n - 1$ voltage levels. At the point in the comparator chain where the reference voltage exceeds the input voltage the comparator outputs will change over from low to high. The comparator outputs are encoded into whatever digital output coding is required.

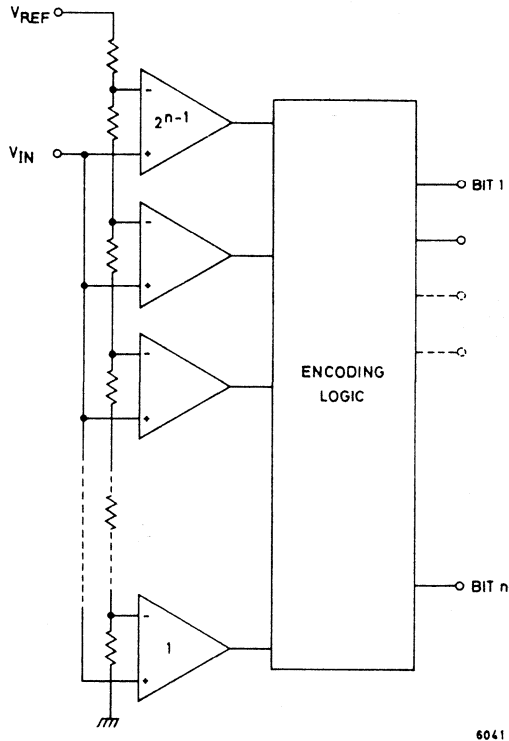

Fig. 10. Parallel A-D Converter

A to D Converters

Since the only delays involved in the conversion are the propagation delay of one comparator plus the logic propagation delays, parallel converters are very fast and may perform in excess of 10 million conversions per second. However, due to the large number of comparators required (63 for a 6-bit converter, 255 for an 8-bit converter) they are expensive to produce. Applications include digital video systems, digital storage oscilloscopes and radar data processing.

2.2.2 Staircase and Comparator

In this type of ADC the input code of a DAC is incremented by a binary counter to give a staircase waveform, as shown in figure 11. This is compared with the analogue input and when the staircase exceeds the analogue voltage the comparator output changes state and stops the clock. The count reached by the binary counter is thus the ADC output code. This method of A to D conversion is relatively simple and cheap, but is also relatively slow, requiring $2^n - 1$ clock pulses for a full scale conversion, where n is the number of bits. This conversion method is used in the ZN425 series of dual-purpose D-A/A-D converters.

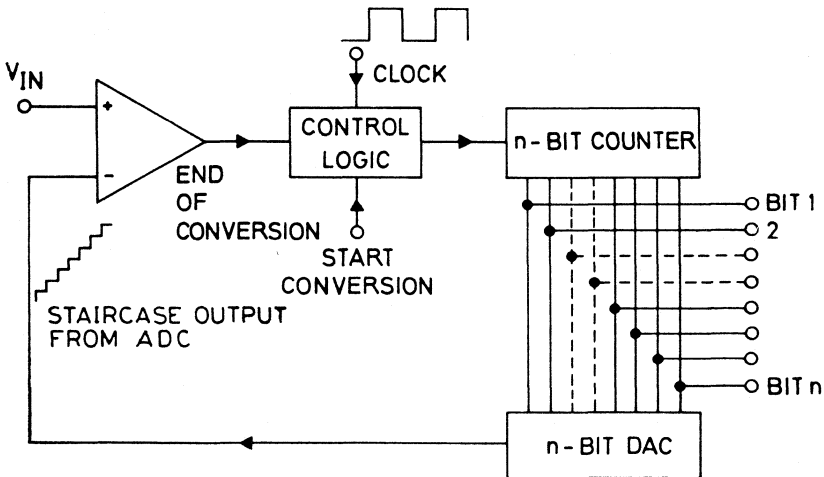

6042

Fig. 11. Staircase (Ramp) and Compare ADC

A to D Converters

2.2.3 Tracking Converters

As its name implies, a tracking converter can follow changing analogue inputs. The principle operation is similar to that of the staircase and compare type of converter, but it uses an up/down counter and a window comparator, as shown in figure 12. When the DAC output is less than the analogue input the comparator instructs the counter to count up and the DAC output thus increases. If the DAC output is greater than the analogue input the comparator causes the counter to count down, thus decreasing the DAC output. When the DAC output is equal to the analogue input $\pm \frac{1}{2}$ LSB, the input is within the 'window' of the comparator and the counter is stopped. This is illustrated in figure 13. A tracking converter has speed advantages over a staircase and compare type, since the counter of the latter type can only count up, and must therefore be reset between conversions. In the case of a tracking converter, once it has performed an initial conversion starting from zero, any subsequent conversions require only that number of clock pulses necessary to track any increase or decrease in input voltage.

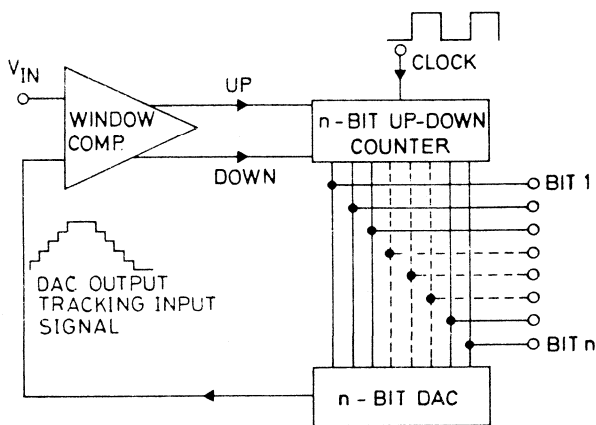

6043

Fig. 12. Tracking ADC

As an extreme example consider an analogue input that changes from V_{FSO} to $(V_{FSO} - 1 \text{ LSB})$. The staircase and compare converter will require $2^n - 1$ clock pulses for the first conversion and $2^n - 2$ clock pulses for the second conversion. The tracking converter on the other hand, will require $2^n - 1$ clock pulses for the first conversion but only one clock pulse for the second conversion. This is illustrated in figure 14.

A to D Converters

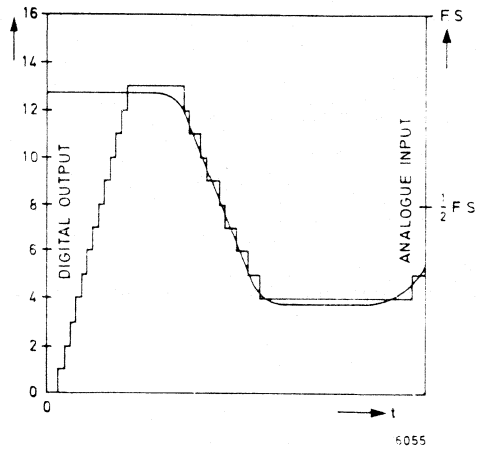

Fig. 13. Operation of Tracking ADC

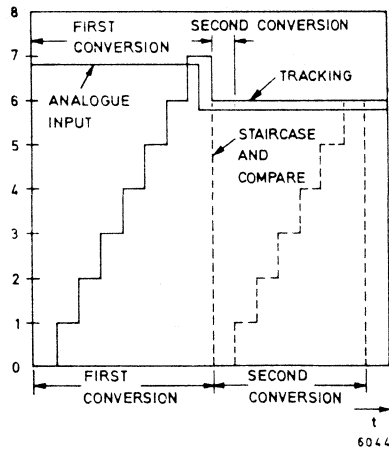

Fig. 14. Comparison of ramp and compare and tracking ADCs

A to D Converters

In general it can be said that a tracking converter will follow signals whose rate of change is less than $\pm 1 \text{ LSB} \times \text{clock frequency}$. If this condition is met there is no need to use a sample-and-hold circuit on the analogue input.

A tracking technique is used in the ZN433 series of converters.

2.2.4 Successive Approximation Converters

The operation of a staircase and compare ADC is analogous to weighing, say an 11 gramme weight, on a balance by adding one gramme weights until the scale tips, which is clearly a very slow method. A faster procedure, known as successive approximation, uses weights of 16, 8, 4, 2 and 1 grammes. The 16 gramme weight is tried first and is discarded because it tips the scale. The 8 gramme weight is tried next, and is left on the pan. Next the 4 gramme weight is tried and discarded, and the 2 and 1 gramme weights are tried and retained. The final result is the sum of the weights remaining on the scale pan, and the operation has taken 5 'cycles' as opposed to 11 'cycles' for the staircase and compare method.

The principle of a successive approximation ADC is identical. The MSB of a DAC is first set to '1' and the output is compared to the analogue input. If it is greater than the input the MSB is reset to '0', otherwise it is left at '1'. The next bit is then set to '1' and the DAC output is again compared to the analogue input. Again it is either reset or left at '1' depending on the result of the comparison. This procedure is repeated for every bit down to the LSB, and the final input code to the DAC is the output code of the ADC. A successive approximation cycle is illustrated in figure 15.

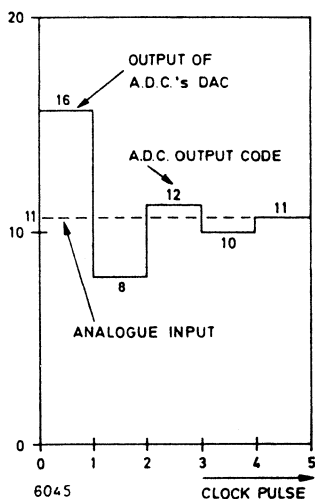

Fig. 15. Operation of a Successive Approximation ADC

A to D Converters

Successive approximation is used in the ZN427 and ZN432 series of converters.

2.2.5 Dual Slope Converters

Dual slope integration is one of the slowest methods of A to D conversion, but it offers high resolution at a modest cost.

A block diagram of a dual-slope converter is shown in figure 16. It operates in the following manner: Switch S1 is closed by the control logic, S4 is opened and the input voltage is integrated for n clock periods, where n is usually the maximum count of the counter. At the end of this time the integrator output voltage, V_o , is $\frac{-V_{in} n T_c}{RC}$ where T_c is the clock period. This is shown in figure 17.

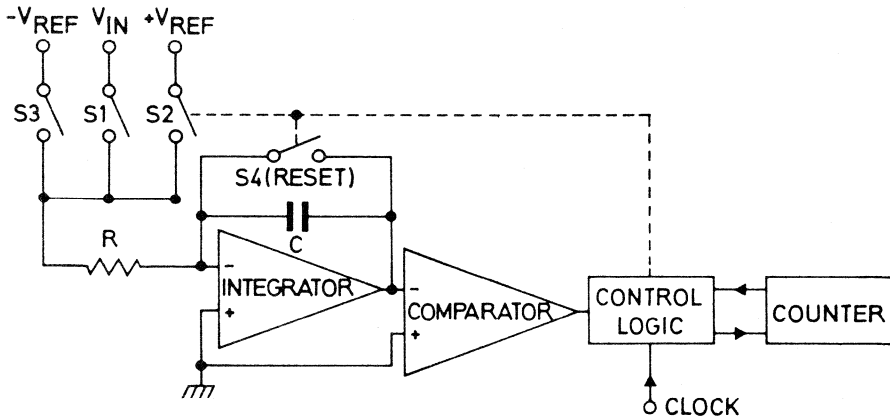

6046

Fig. 16. Dual-Slope ADC

During this period the polarity of the input signal is detected by the comparator. At the end of the integration period S1 is opened and, depending on the polarity of V_{in} , either S2 or S3 is closed to connect the integrator to a reference voltage of opposite polarity to V_{in} . The counter is now allowed to count from zero until the integrator output reaches 0 volts, when the comparator output changes state and the counter is stopped. Since the integration is over the same voltage range (V_o), $V_o = \frac{-V_{REF} \times T_c}{RC}$, where x is the count

A to D Converters

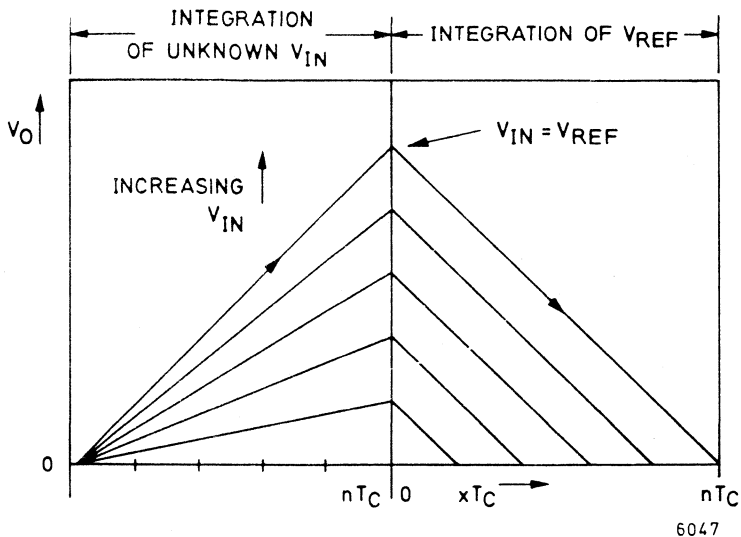

Fig. 17. Operation of Dual-Slope ADC

reached by the time the integrator output crosses zero. Thus

$$\frac{V_{in} \cdot n T_c}{RC} = \frac{V_{REF} \cdot x T_c}{RC}$$

$$\text{or } x = \frac{V_{in} \cdot n}{V_{REF}}$$

Since \$n\$ and \$V_{REF}\$ are both fixed the output count is proportional to the input voltage. Since both the first and second integrations occur under identical conditions the converter is unaffected by any long-term variations in \$T_c\$, \$R\$ or \$C\$, as demonstrated by the disappearance of these terms from the final equation. The only factors affecting the accuracy of the converter are (1) the stability of \$V_{REF}\$ (2) the stability of the 'on' resistance of \$S1\$ to \$S3\$ and (3) drift in the integrator and comparator op-amps. These effects can be minimised by careful design.

Dual slope converters are generally used where high resolution and low cost are more important than speed, for example in digital voltmeters.

The ZNA116 and ZNA216 are DVM logic subsystems containing the clock, counter and all control logic necessary for dual slope converter or DVM.

A to D Converters

2.3 A to D Parameters and Definitions

2.3.1 A to D Converter Errors

Like DACs, practical ADCs are subject to a number of error sources, and since most ADCs contain a reference DAC, many of these error sources are the same for both types of converter.

2.3.2 Quantising Error (Uncertainty)

Quantising error is an ADC specification that has no counterpart in DAC specifications. For each input code of a DAC there is a unique analogue output level, but for any ADC output code there is a 1 LSB range of analogue input levels. It is thus not possible to tell from the output code the precise value of the analogue input level, there being a quantising error or uncertainty of $\pm \frac{1}{2}$ LSB. Since all ADCs have this inherent quantising error the parameter is frequently not quoted in specifications.

2.3.3 Missing Codes

Missing codes are perhaps best explained by considering the operation of a staircase and compare type 3-bit ADC which has a non-monotonic DAC, as shown in figure 18. The reference DAC exhibits non-monotonicity at input code 4, i.e. step 4 of the staircase decreases. There is thus no way in which the counter can be stopped at this code. If the analogue input is less than the DAC output for code 3 then the comparator will stop the counter before 4 is reached. If the analogue input is greater than output 3 it must also be greater than output 4, so the comparator will not change state at code 4.

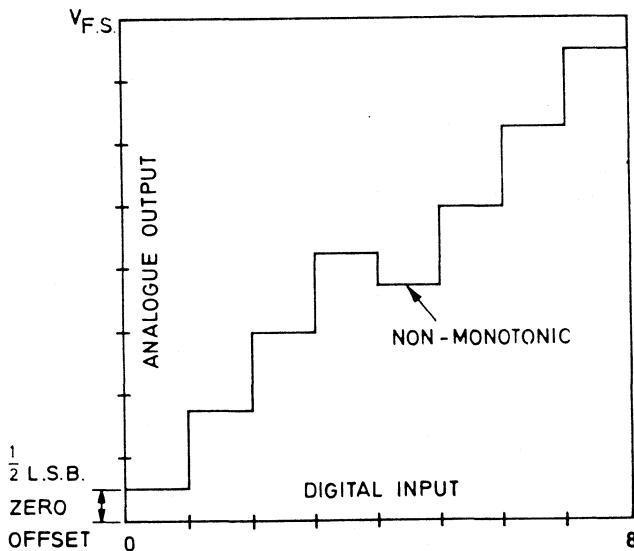

Fig. 18. Non-monotonic DAC used in an ADC

A to D Converters

Output code 4 will thus never appear and is known as a 'missing' code. The transfer function of an ADC with a missing code is shown in figure 19.

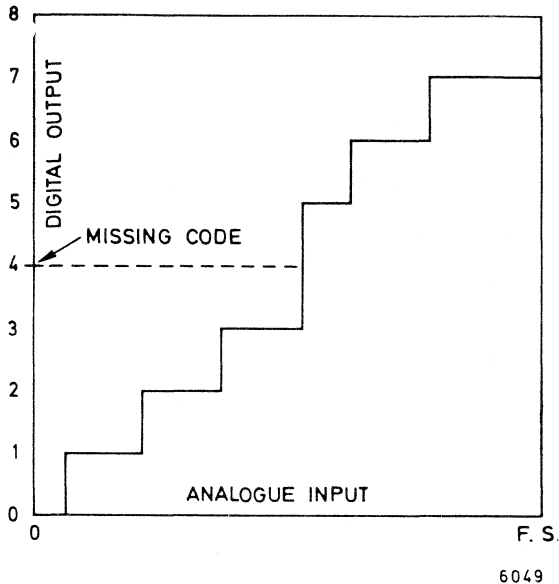

Fig. 19. ADC With Missing Code

2.3.4 Zero Transition

As explained earlier, the zero of an ADC is usually trimmed so that the output transition from 0 to 1 occurs at an input level corresponding to $\frac{1}{2}$ LSB, i.e. $\frac{1}{2} \frac{V_{FS}}{2^n}$. However, as supplied the reference DAC of an ADC I.C. will not have the $\frac{1}{2}$ LSB offset necessary to achieve this. The zero transition will thus occur at 1 LSB plus the DAC zero error, plus the comparator offset voltage. These three parameters are frequently lumped together as the (untrimmed) zero transition of the ADC.

2.3.5 Gain Error

This is the difference between the slope of a line drawn between the actual zero and full scale transition points and that of a line drawn through the ideal transition points.

2.3.6 Non-linearity (Linearity Error)

Non-linearity is the maximum amount by which any actual transition points deviates from the corresponding ideal transition point. It is specified as a percentage of full-scale or a fraction of an LSB. A linearity error of less than $\pm \frac{1}{2}$ LSB assures no missing codes.

A to D Converters

2.3.7 Differential Non-linearity

This is the maximum difference between any 1 LSB increment of the analogue input and the ideal size of an LSB increment $\frac{V_{FS}}{2^n}$. Differential non-linearity of less than 1 LSB guarantees no missing codes.

2.3.8 Resolution

The resolution of an ADC is simply the number of bit outputs that the converter possesses. As with a DAC, resolution implies nothing about the accuracy of a device.

2.3.9 Useful Resolution

Useful resolution is the resolution (number of bits) at which an ADC has no missing codes, which for Ferranti ADCs is guaranteed over the operating temperature range. As with DACs, an n-bit ADC may have a useful resolution less than n bits, for reasons previously explained.

2.3.10 Conversion Time

The time taken for an ADC to perform a complete conversion is known as the conversion time. For successive approximation converters conversion time is fixed by the number of bits and the clock frequency. However, for other types, conversion time may vary with input voltage. For example, a ramp and compare ADC requires $2^n - 1$ clock pulses for a full scale conversion but only one clock pulse for a one bit conversion. It is thus important to check exactly what is being specified.

2.4 Bipolar Operation

As with a DAC, an ADC may be used for bipolar operation. Taking the ZN427 as an example the input is offset by $\frac{+V_{REF}}{2}$ so that the input voltage presented to the ADC is always positive, even with negative input voltages down to $\frac{-V_{REF}}{2}$. The principle of offsetting an ADC input is illustrated in figure 20, whilst the transfer function of a 3 bit bipolar ADC is shown in figure 21. In this case the **output** coding is known as offset binary.

A to D Converters

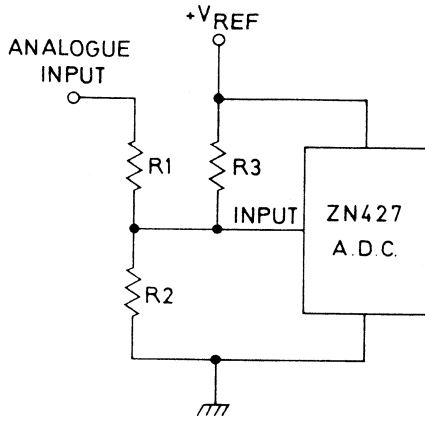

6050

Fig. 20. Bipolar Operation of an ADC

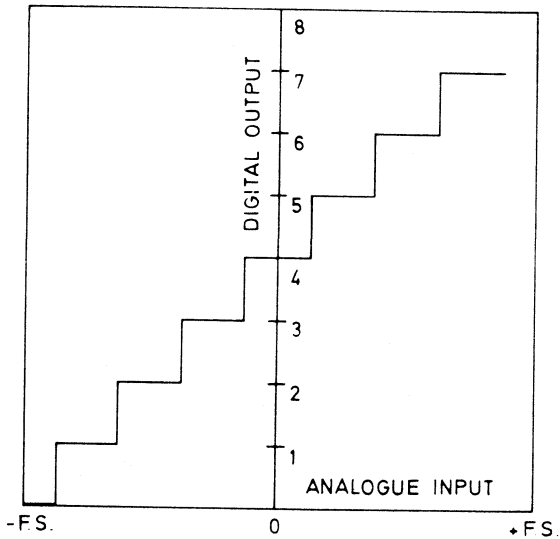

6051

Fig. 21. Bipolar Transfer Characteristic of an ADC

Microprocessor Compatible 8 Bit Successive Approximation A - D Converter
FEATURES

- Easy interfacing to microprocessors, or operates as a 'stand-alone' converter
- Fast: 10 μ s conversion time guaranteed
- No missing codes over operating temperature range
- Data outputs 3-state TTL compatible, other logic inputs and outputs TTL and CMOS compatible
- Choice of on-chip or external voltage reference
- Ratiometric operation
- Unipolar and bipolar input ranges
- Complementary to ZN428 DAC
- Choice of commercial or military temperature range

DESCRIPTION

The ZN427 is an 8-bit successive approximation converter with 3-state outputs to permit easy interfacing to a common data bus. The IC contains a voltage switching DAC, a fast comparator, successive approximation logic and a 2.56 volt precision band-gap reference, the use of which is pin-optional to retain flexibility. An external fixed or varying reference may therefore be substituted, thus allowing ratiometric operation.

Only passive external components are required for operation of the converter.

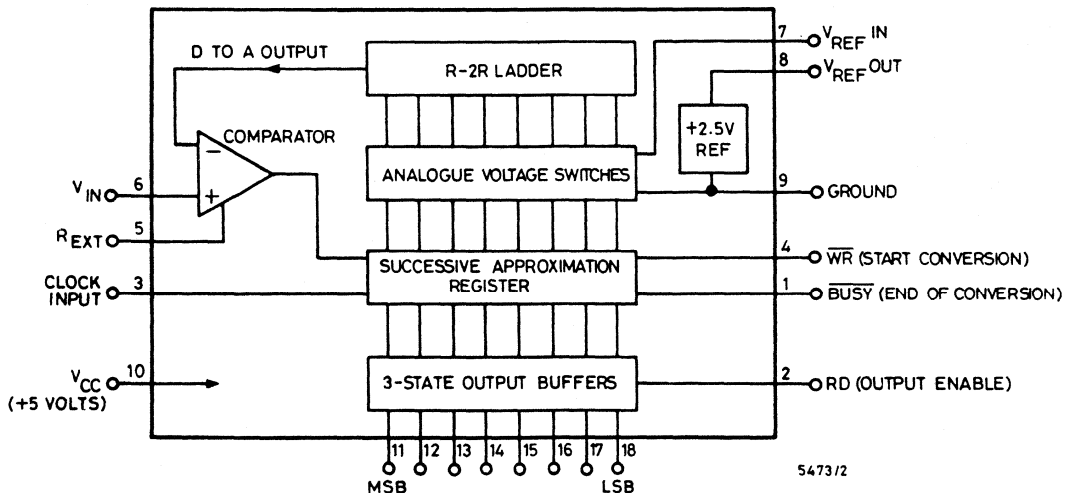

Fig. 1 – System Diagram

ZN427E-8/J-8

ABSOLUTE MAXIMUM RATINGS

Supply Voltage, V_{CC}	+7.0 volts
Max. Voltage, Logic and V_{REF} inputs	V_{CC}
Operating temperature range	0°C to +70°C (ZN427E-8) -55°C to +125°C (ZN427J-8)
Storage temperature range	-55°C to +125°C

ELECTRICAL CHARACTERISTICS ($V_{CC} = 5V$, $T_{amb} = 25^\circ C$ unless otherwise specified).

Parameter	Min.	Typ.	Max.	Units	Conditions
CONVERTER					
Resolution	8	—	—	Bits	
Linearity Error	—	—	± 0.5	LSB	
Differential Non-Linearity	—	± 0.5	—	LSB	
Linearity Error T.C.	—	± 3	—	ppm/°C	
Differential Non-Linearity T.C.	—	± 6	—	ppm/°C	
Full Scale (Gain) T.C.	—	± 2.5	—	ppm/°C	External Ref. 2.5V
Zero T.C.	—	± 8	—	$\mu V/^\circ C$	
Zero Transition 00000000 to 00000001	12	15	18	mV	$V_{REF IN} = 2.560V$
F.S. Transition 11111110 to 11111111	2.545	2.550	2.555	V	$V_{REF IN} = 2.560V$
Conversion Time	—	—	10	μs	See Note 1
External Reference Voltage	1.5	—	3.0	V	
Supply Voltage (V_{CC})	4.5	—	5.5	V	
Supply Current	—	25	40	mA	
Power Consumption	—	125	—	mW	
COMPARATOR					
Input Current	—	1	—	μA	$V_{IN} = 3V$, $R_{EXT} = 82k\Omega$
Input Resistance	—	100	—	k Ω	$V_- = -5V$
Tail Current, I_{EXT}	25	—	150	μA	
Negative Supply, V_-	-3.0	—	-30.0	V	See COMPARATOR
Input Voltage	-0.5	—	3.5	V	
INTERNAL VOLTAGE REFERENCE					
Output Voltage	2.475	2.560	2.625	V	$R_{REF} = 390\Omega$ $C_{REF} = 4 \mu 7$
Slope Resistance	—	0.5	2	Ω	
V_{REF} Temperature Coefficient	—	50	—	ppm/°C	
Reference Current	4	—	15	mA	See REFERENCE

ZN427E-8/J-8

ELECTRICAL CHARACTERISTICS (continued)

	Min.	Typ.	Max.	Units	Conditions
LOGIC					
(over operating temp.)					
High Level Input Voltage V_{IH}	2	—	—	V	
Low Level Input Voltage V_{IL}	—	—	0.8	V	
High Level Input Current, WR and RD inputs I_{IH}	—	—	50	μ A	$V_{IN} = 5.5V, V_{CC} = \text{max.}$
High Level Input Current, Clock Input I_{IH}	—	—	15	μ A	$V_{IN} = 2.4V, V_{CC} = \text{max.}$
Low Level Input Current I_{IL}	—	—	100	μ A	$V_{IN} = 5.5V, V_{CC} = \text{max.}$
Low Level Input Current I_{IL}	—	—	30	μ A	$V_{IN} = 2.4V, V_{CC} = \text{max.}$
High Level Output Current I_{OL}	—	—	-5	μ A	$V_{IN} = 0.4V, V_{CC} = \text{max.}$
Low Level Output Current I_{OL}	—	—	-100	μ A	
High Level Output Voltage V_{OH}	2.4	—	—	V	$I_{OH} = \text{max.}, V_{CC} = \text{min.}$
Low Level Output Voltage V_{OL}	—	—	0.4	V	$I_{OL} = \text{max.}, V_{CC} = \text{min.}$
Disabled Output Leakage	—	—	2	μ A	$V_O = 2.4V$
Input Clamp Diode Voltage	—	—	-1.5	V	
Read Input to Data Output	—	—	250	ns	See Fig. 8
Enable/Disable Delay Time t_{RD}	—	180	250	ns	
Start Pulse Width t_{WR}	250	160	—	ns	See Fig. 8
WR to BUSY Propagation Delay t_{BD}	—	—	250	ns	
Clock Pulse Width	500	—	—	ns	
Maximum Clock Frequency	900	1000	—	kHz	See Note 1

Note 1 : A 900 kHz clock gives a conversion time of $10\mu\text{s}$ (9 clock periods).

GENERAL CIRCUIT OPERATION

The ZN427 utilises the successive approximation technique. Upon receipt of a negative-going pulse at the WR input the BUSY output goes low, the MSB is set to 1 and all other bits are set to 0, which produces an output voltage of $V_{REF}/2$ from the DAC. This is compared to the input voltage V_{IN} ; a decision is made on the next negative clock edge to reset the MSB to 0 if $\frac{V_{REF}}{2} > V_{IN}$ or leave it set to 1 if $\frac{V_{REF}}{2} < V_{IN}$. Bit 2 is set to 1 on the same clock edge, producing an output from the DAC of $\frac{V_{REF}}{4}$ or $\frac{V_{REF}}{2} + \frac{V_{REF}}{4}$ depending on the state of the MSB. This voltage is compared to V_{IN} and on the next clock edge a decision is made regarding bit 2, whilst bit 3 is set to 1. This procedure is repeated for all eight bits. On the ninth negative clock edge BUSY goes high indicating that the conversion is complete.

During a conversion the RD input will normally be held low to keep the 3-state buffers in their high impedance state. Data can be read out by taking RD high, thus enabling the 3-state outputs. Readout is non-destructive. The BUSY output may be tied to the RD input to automatically enable the outputs when the data is valid.

ZN427E-8/J-8

For reliable operation of the converter the start pulse applied to the \overline{WR} input must meet certain timing criteria with respect to the converter clock. These are detailed in the timing diagram of figure 2.

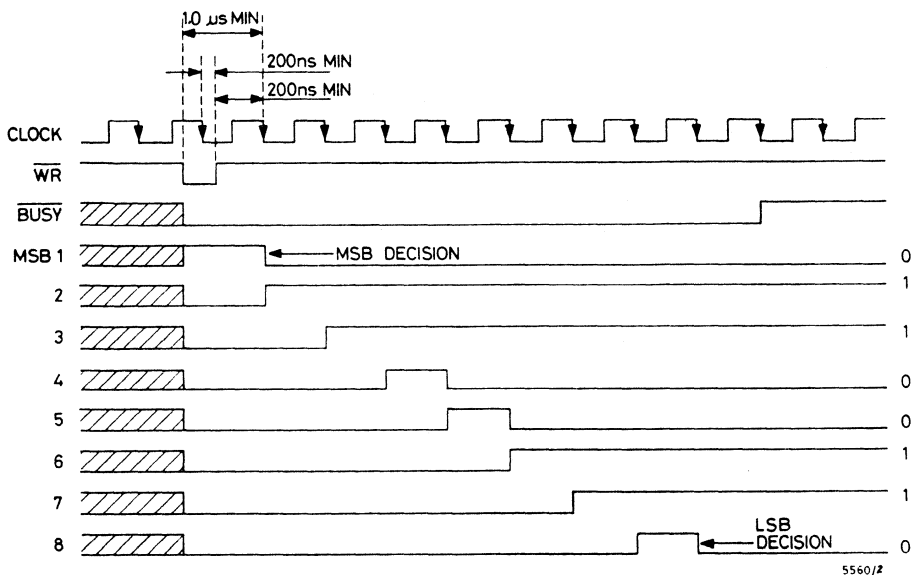

Fig. 2 Timing Diagram

NOTES ON TIMING DIAGRAM

1. A conversion sequence is shown for the digital word 01100110. For clarity the 3-state outputs are shown as being enabled during the conversion, but normal practice would be to disable them until the conversion was complete.
2. The \overline{BUSY} output goes low during a conversion. When \overline{BUSY} goes high at the end of a conversion the output data is valid. In a microprocessor system the \overline{BUSY} output can be used to generate an interrupt request when the conversion is complete.
3. In the timing diagram cross hatching indicates a 'don't care' condition.
4. The start pulse operates as an asynchronous (independent of clock) reset that sets the MSB output to 1 and sets all other outputs and the end of conversion flag to 0. This resetting occurs on the low-going edge of the start pulse and as long as \overline{WR} is low the converter is inhibited. Conversion commences on the first active (negative going) clock edge after the \overline{WR} input has gone high again, when the MSB decision is made. A number of timing constraints thus apply to the start pulse.
 - (a) The minimum duration of the start pulse is 250ns, to allow reliable resetting of the converter logic circuits.
 - (b) There is no limit to the maximum duration of the start pulse.

ZN427E-8/J-8

- (c) To allow the MSB to settle at least $1.5\mu\text{s}$ must elapse between the negative going edge of the start pulse and the first active clock edge that initiates the MSB decision.
- (d) To ensure reliable clocking the positive-going edge of the start pulse should not occur within 200 ns of an active (negative-going) clock edge. The ideal place for the positive-going edge of the start pulse is coincident with a positive-going clock edge. As a special case of the above conditions the start pulse may be synchronous with a negative-going clock pulse.

PRACTICAL CLOCK AND SYNCHRONISING CIRCUITS

The actual method of generating the clock signal and synchronising it to the start conversion pulse (or vice versa) will depend on the system in which the ZN427 is incorporated.

When used with a microprocessor the ZN427 can be treated as RAM and can be assigned a memory address using an address decoder. If the μP clock is used to drive the ZN427 and the μP write pulse meets the ZN427 timing criteria with respect to the μP clock then generating the start pulse is simply a matter of gating the decoded address with the microprocessor write pulse. Whilst the conversion is being performed the microprocessor can perform other instructions or No operation (NOP). When the conversion is complete the outputs can be enabled onto the data bus by gating the decoded address with the read pulse. A timing diagram for this sequence of operations is given in figure 3.

An advantage of using the microprocessor clock is that the conversion time is known precisely in terms of machine cycles. The data outputs may therefore be read after a fixed delay of at least nine clock cycles after the end of the $\overline{\text{WR}}$ pulse, when the conversion will be complete.

Alternatively the read operation may be initiated by using the $\overline{\text{BUSY}}$ output to generate an interrupt request.

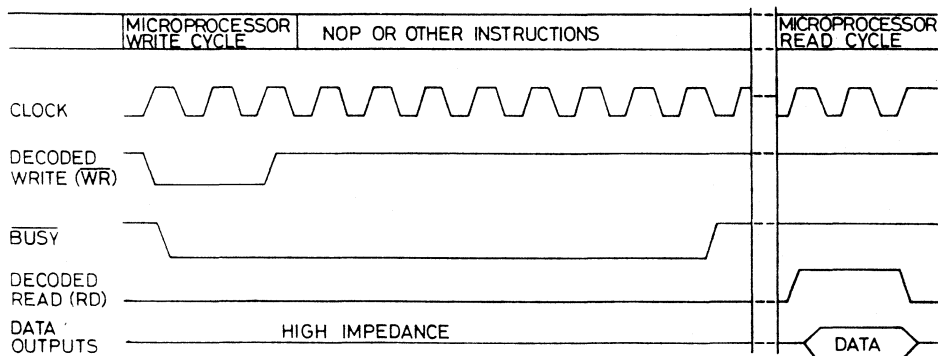

6373

Fig. 3 Typical Timing Diagram Using μP clock and Write Pulse

In some systems, for example single-chip microcomputers such as the 8048, this simple method may not be feasible for one or more of the following reasons:

- (a) The MPU clock is not available externally.
- (b) The clock frequency is too high.

ZN427E-8/J-8

(c) The write pulse timing criteria make it unsuitable for direct use as a start conversion pulse. If any of these conditions apply then the self-synchronising clock circuit of figure 4a is recommended.

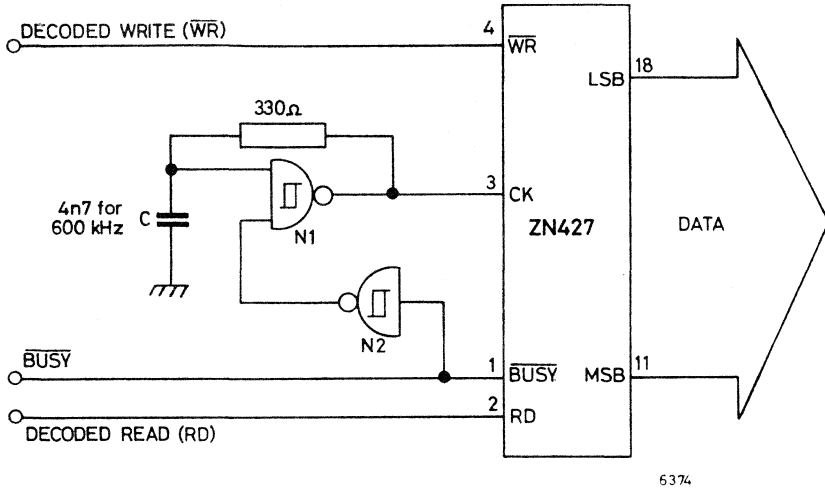

N1 N2 = ZN7413 or 1/2 74132 Schmitt Trigger

$$f_{CK} = \frac{1}{360 \cdot C} \text{ (Hz, F)}$$

Fig. 4a. Self-Synchronising Clock Circuit

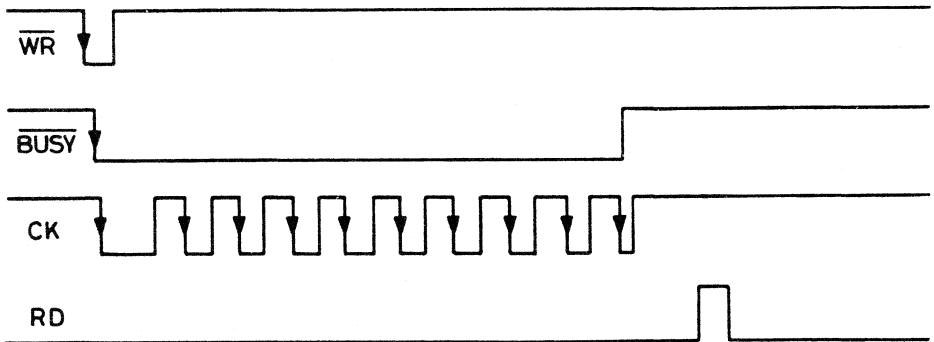

6375

Fig 4b. Timing Diagram For Circuit of Figure 4a.

ZN427E-8/J-8

N1 is connected as an astable multivibrator which, when the $\overline{\text{BUSY}}$ output is high, is inhibited by the output of N2 holding one of its inputs low. The start conversion pulse resets the $\overline{\text{BUSY}}$ flag and N1 begins to oscillate. When the conversion is completed $\overline{\text{BUSY}}$ goes high and the clock is inhibited.

Since the start pulse starts the clock it may occur at any time. The only constraints on the start pulse are that it must be longer than 250 ns but at least 200 ns shorter than the first clock pulse. The first clock pulse is in fact longer than the rest since C1 starts from a fully charged condition whereas on subsequent cycles it charges between the upper and lower thresholds (V_{T+} and V_{T-}) of the Schmitt trigger.

LOGIC INPUTS AND OUTPUTS

The logic inputs of the ZN427 utilise the emitter-follower configuration shown in fig. 5. This gives extremely low input currents for CMOS as well as TTL compatibility.

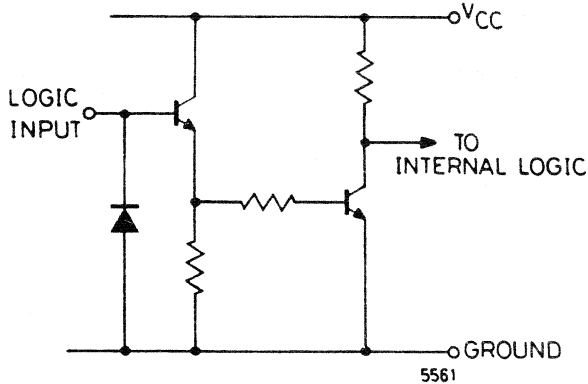
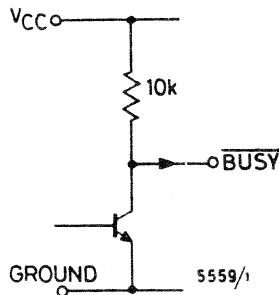

Fig. 5. Equivalent Circuit of all Inputs

The $\overline{\text{BUSY}}$ output, shown in figure 6, utilises a passive pullup for CMOS/TTL compatibility



The data outputs have 3-state buffers, an equivalent circuit of which is shown in figure 7. Whilst the RD input is low both output transistors are turned off and the output is in a high impedance state. When RD is high the data output will assume the appropriate logic state (0 or 1).

ZN427E-8/J-8

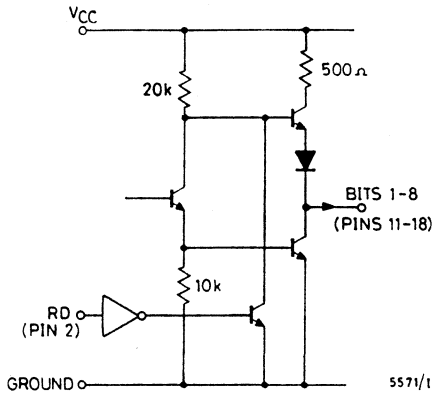

Fig. 7. Equivalent Circuit of Data Outputs

A test circuit and timing diagram for the output enable/disable delays are given in figure 8.

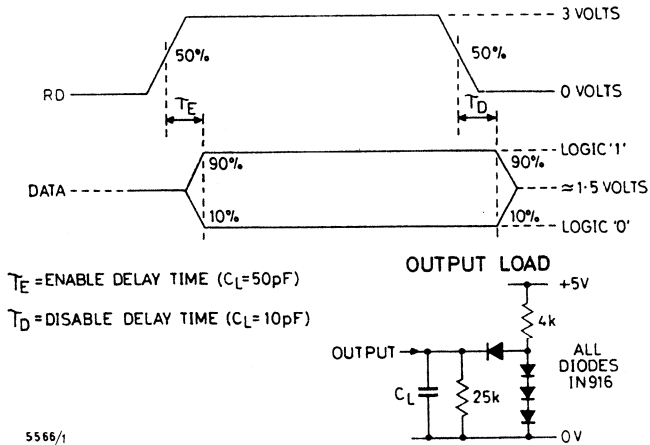

Fig. 8. Output Enable/Disable Waveforms

ANALOGUE CIRCUITS

D to A CONVERTER

The converter is of the voltage switching type and uses an R-2R ladder network as shown in figure 9. Each element is connected to either 0V or $V_{REF IN}$ by transistor voltage switches specially designed for low offset voltage (<1 millivolt).

A binary weighted voltage is produced at the output of the R-2R ladder:

$$\text{D to A output} = \frac{n}{256} (V_{REF IN} - V_{OS}) + V_{OS}$$

where n is the digital input to the D to A from the successive approximation register.

V_{OS} is a small offset voltage that is produced by the device supply current flowing in the package lead resistance. The value of V_{OS} is typically 2 mV for the ZN427E-8 (4 mV, ZN427J-8). This offset will normally be removed by the setting up procedure and since the offset temperature coefficient is low (8 $\mu\text{V}/^\circ\text{C}$) the effect on accuracy will be negligible.

The D to A output range can be considered to be $0 - V_{REF IN}$ through an output resistance R (4k Ω)

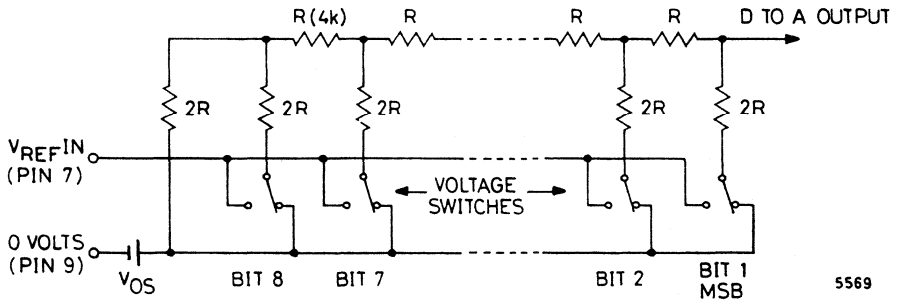

Fig. 9. R2-R Ladder Network

REFERENCE

(a) Internal Reference

The internal reference is an active band gap circuit which is equivalent to a 2.5V Zener diode with a very low slope impedance (Fig. 10). A resistor (R_{REF}) should be connected between pins 8 and 10. The recommended value of 390 Ω will supply a nominal reference current of $(5.0 - 2.5) / 0.39 = 6.4\text{mA}$. A stabilising/decoupling capacitor, C_{REF} (4 μF), is required between pins 8 and 9. For internal reference operation $V_{REF OUT}$ (Pin 8) is connected to $V_{REF IN}$ (Pin 7).

Up to five ZN427's may be driven from one internal reference, there being no need to reduce R_{REF} . This useful feature saves power and gives excellent gain tracking between the converters.

Alternatively the internal reference can be used as the reference voltage for other external circuits and can source or sink up to 3mA.

ZN427E-8/J-8

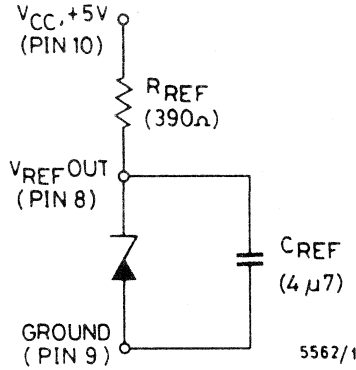

Fig. 10 Internal Voltage Reference

(b) External Reference

If required an external reference voltage in the range +1.5 to +3.0 volts may be connected to $V_{REF IN}$. The slope resistance of such a reference source should be less than $\frac{2.5\Omega}{n}$ where n is the number of converters supplied.

RATIOMETRIC OPERATION

If the output from a transducer varies with its supply then an external reference for the ZN427 should be derived from the same supply. The external reference can vary from +1.5 volts to +3.0 volts. The ZN427 will operate if $V_{REF IN}$ is less than +1.5 volts but reduced overdrive to the comparator will increase its delay and so the conversion time will need to be increased.

COMPARATOR

The ZN427 contains a fast comparator, the equivalent input circuit of which is shown in Fig. 11.

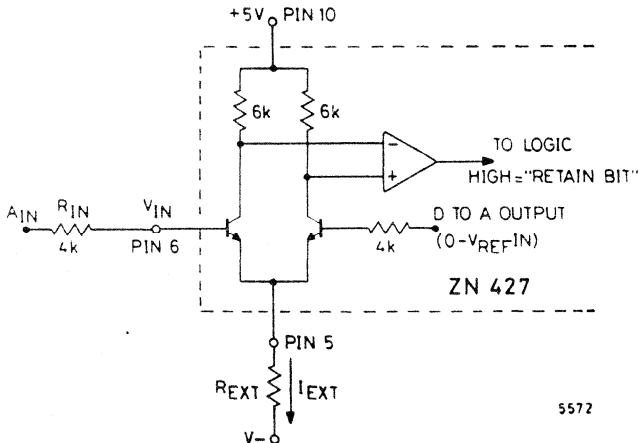

Fig. 11 Comparator Equivalent Circuit

ZN427E-8/J-8

The comparator derives the tail current, I_{EXT} , for its first stage from an external resistor, R_{EXT} , which is taken to a negative supply V_- .

This arrangement allows the ZN427 to work with any negative supply in the range -3 to -30 volts. The ZN427 is designed to be insensitive to changes in I_{EXT} from $25\mu A$ to $150\mu A$. The suggested nominal value of I_{EXT} is $65\mu A$ and a suitable value for R_{EXT} is given by $R_{EXT} = |V_-| 15k\Omega$.

V- (Volts)	$R_{EXT} (\pm 10\%)$
-3	47k Ω
-5	82k Ω
-10	150k Ω
-12	180k Ω
-15	220k Ω
-20	330k Ω
-25	390k Ω
-30	470k Ω

The output from the D to A converter is connected through the $4k\Omega$ ladder resistance to one side of the comparator. The analogue input to be converted could be connected directly to the other comparator input (V_{IN} , Pin 6) but for optimum stability with temperature the analogue input should be applied through a source resistance ($R_{IN} = 4k\Omega$) to match the ladder resistance.

ANALOGUE INPUT RANGES

The basic connection of the ZN427 shown in fig. 12 has an analogue input range 0 to V_{REFIN} , which, in some applications, may be made available from previous signal conditioning/scaling circuits. Input voltage ranges greater than this are accommodated by providing an attenuator on the comparator input, whilst for smaller input ranges the signal must be amplified to a suitable level.

Bipolar input ranges are accommodated by offsetting the analogue input range so that the comparator always sees a positive input voltage.

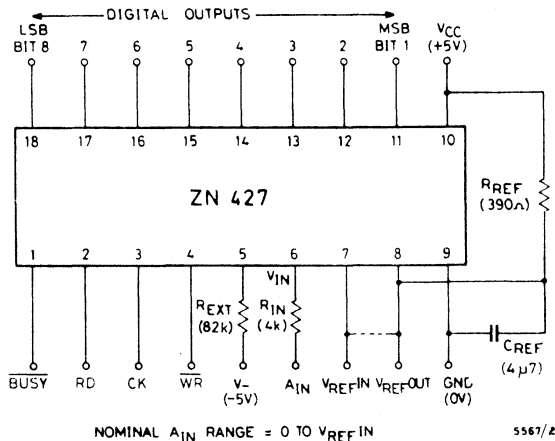

Fig. 12. External Components for Basic Operation

ZN427E-8/J-8

UNIPOLAR OPERATION

The general connection for unipolar operation is shown in figure 13.

The values of R_1 and R_2 are chosen so that $V_{IN} = V_{REF IN}$ when the Analogue Input (A_{IN}) is at full scale. The resulting full scale range is given by :

$$A_{IN FS} = \left(1 + \frac{R_1}{R_2}\right), V_{REF IN} = G \cdot V_{REF IN}$$

To match the ladder resistance $R_1 // R_2 (\approx R_{1N}) = 4k\Omega$.

The required nominal values of R_1 and R_2 are given by $R_1 = 4G k\Omega$, $R_2 = \frac{4G}{G-1} k\Omega$.

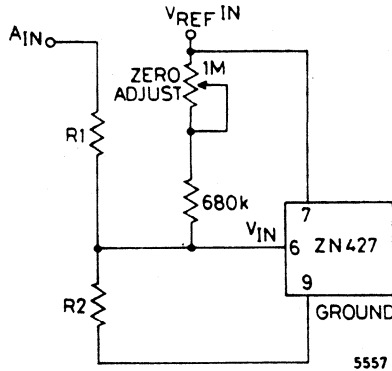

Fig. 13 Unipolar Operation - General Connection

Using these relationships a table of nominal values of R_1 and R_2 can be constructed for $V_{REF IN} = 2.5$ volts.

Input Range	G	R_1	R_2
+5V	2	8k Ω	8k Ω
+10V	4	16k Ω	5.33k Ω

GAIN ADJUSTMENT

Due to tolerances in R_1 and R_2 , tolerances in V_{REF} and the gain (full-scale) error of the DAC, some adjustment should be incorporated into R_1 to calibrate the full-scale of the converter. When used with the internal reference and 2% resistors a preset capable of adjusting R_1 by at least $\pm 5\%$ of its nominal value is suggested.

ZERO ADJUSTMENTS

Due to offsets in the DAC and comparator the zero (0 to 1) code transition would occur with typically 15mV applied to the comparator input, which corresponds to $+1\frac{1}{2}$ LSB with a 2.56 volt reference.

ZN427E-8/J-8

Zero adjustment must therefore be provided to set the zero transition to its correct value of $+\frac{1}{2}$ LSB or 5mV with a 2.56V reference. This is achieved by applying an adjustable positive offset to the comparator input via P2 and R3. The values shown are suitable for all input ranges greater than $1\frac{1}{2}$ times $V_{REF IN}$.

Practical circuit values for +5V and +10V input ranges are given in fig. 14, which incorporate both zero and gain adjustments.

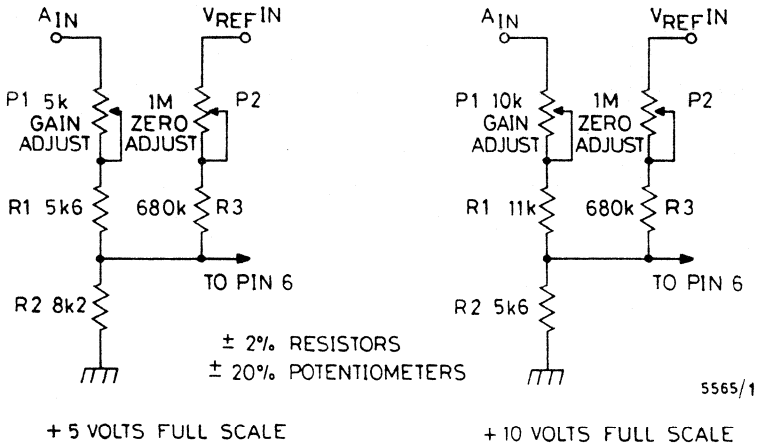

Fig. 14. Unipolar Operation - Component Values

UNIPOLAR ADJUSTMENT PROCEDURE

- (i) Apply continuous SC pulses at intervals long enough to allow a complete conversion and monitor the digital outputs.
- (ii) Apply full scale minus $1\frac{1}{2}$ LSB to A_{IN} and adjust gain until Bit 8 (LSB) output just flickers between 0 and 1 with all other bits at 1.
- (iii) Apply $\frac{1}{2}$ LSB to A_{IN} and adjust zero until Bit 8 just flickers between 0 and 1 with all other bits at 0.

UNIPOLAR SETTING-UP POINTS

Input Range, +FS	$\frac{1}{2}$ LSB	FS $-1\frac{1}{2}$ LSB
+5V	9.8 mV	4.9707 volts
+10V	19.5 mV	9.9414 volts

$$1 \text{ LSB} = \frac{FS}{256}$$

ZN427E-8/J-8

UNIPOLAR LOGIC CODING

Analogue Input (A_{IN}) (Nominal code centre value)	Output Code (Binary)
FS -1 LSB	11111111
FS -2 LSB	11111110
FS	11000000
FS + 1 LSB	10000001
FS	10000000
FS - 1 LSB	01111111
FS	01000000
1 LSB	00000001
0	00000000

BIPOLAR OPERATION

For bipolar operation the input to the ZN427 is offset by half full scale by connecting a resistor R_3 between $V_{REF IN}$ and V_{IN} (Fig. 15).

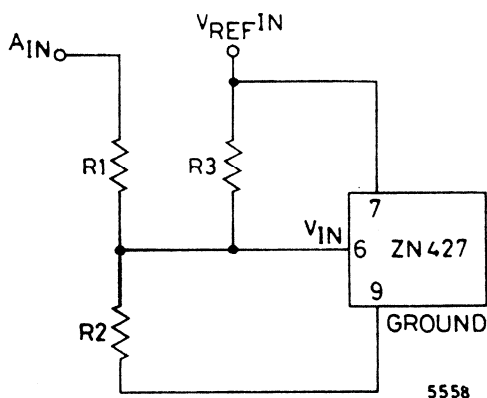

Fig. 15. Bipolar Operation - General Connection

When $A_{IN} = -FS$, V_{IN} needs to be equal to zero.

When $A_{IN} = +FS$, V_{IN} needs to be equal to $V_{REF IN}$.

If the full scale range is $\pm G \cdot V_{REF IN}$ then $R_1 = (G - 1) \cdot R_2$ and $R_1 = G \cdot R_3$ fulfil the required conditions.

To match the ladder resistance $R_1/R_2/R_3 (=R_{IN}) = 4k\Omega$.

Thus the nominal values of R_1, R_2, R_3 are given by $R_1 = 8 Gk\Omega$, $R_2 = 8G/(G - 1)k\Omega$, $R_3 = 8k\Omega$.

A bipolar range of $\pm V_{REF IN}$ (which corresponds to the basic unipolar range 0 to $+V_{REF IN}$) results if $R_1 = R_3 = 8k\Omega$ and $R_2 = \infty$.

Assuming that $V_{REF IN} = 2.5$ volts the nominal values of resistors for $\pm 5V$ and $\pm 10V$ input ranges are given in the following table.

Input Range	G	R_1	R_2	R_3
$\pm 5V$	2	16 k Ω	16 k Ω	8 k Ω
$\pm 10V$	4	32 k Ω	10.66 k Ω	8 k Ω

Minus full scale (offset) is set by adjusting R_1 about its nominal value relative to R_3 . Plus full scale (gain) is set by adjusting R_2 relative to R_1 .

Practical circuit realisations are given in Fig. 16.

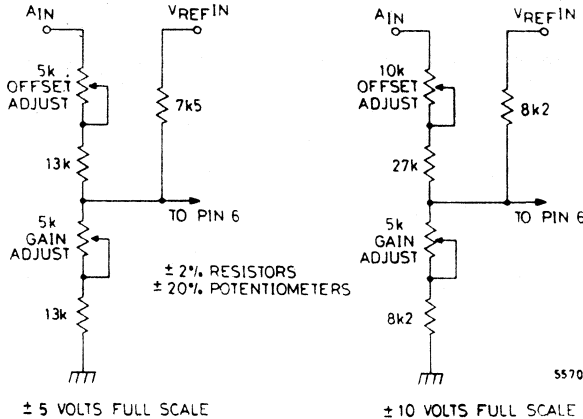

Fig. 16 Bipolar Operation - Component Values

Note that in the $\pm 5V$ case R_3 has been chosen as 7.5 k Ω (instead of 8.2 k Ω) to obtain a more symmetrical range of adjustment using standard potentiometers.

BIPOLAR ADJUSTMENT PROCEDURE

- (i) Apply continuous SC pulses at intervals long enough to allow a complete conversion and monitor the digital outputs.
- (ii) Apply $-(FS - \frac{1}{2} \text{ LSB})$ to A_{1N} and adjust offset until the Bit 8 (LSB) output just flickers between 0 and 1 with all other bits at 0.
- (iii) Apply $+(FS - 1\frac{1}{2} \text{ LSB})$ to A_{1N} and adjust gain until Bit 8 just flickers between 0 and 1 with all other bits at 1.
- (iv) Repeat step (ii).

BIPOLAR SETTING-UP POINTS

Input Range, $\pm FS$	$-(FS - \frac{1}{2} \text{ LSB})$	$+(FS - 1\frac{1}{2} \text{ LSB})$
$\pm 5V$	-4.9805V	+4.9414V
$\pm 10V$	-9.9609V	+9.8828V

$$1 \text{ LSB} = \frac{2FS}{256}$$

ZN427E-8/J-8

BIPOLAR LOGIC CODING

Analogue Input (A_{IN}) (Nominal code centre value)	Output Code (Offset Binary)
+ (FS - 1 LSB)	11111111
+ (FS - 2 LSB)	11111110
+ $\frac{1}{2}$ FS	11000000
+ 1 LSB	10000001
0	10000000
-1 LSB	01111111
- $\frac{1}{2}$ FS	01000000
- (FS - 1 LSB)	00000001
-FS	00000000

SINGLE 5 VOLT SUPPLY RAIL OPERATION

The ZN427 takes very little power from the negative rail and so a suitable negative supply can be generated very easily using a 'diode pump' circuit. The circuit shown in Fig. 17 works with any clock frequency from 10 kHz to 1 MHz and can supply up to five ZN427s.

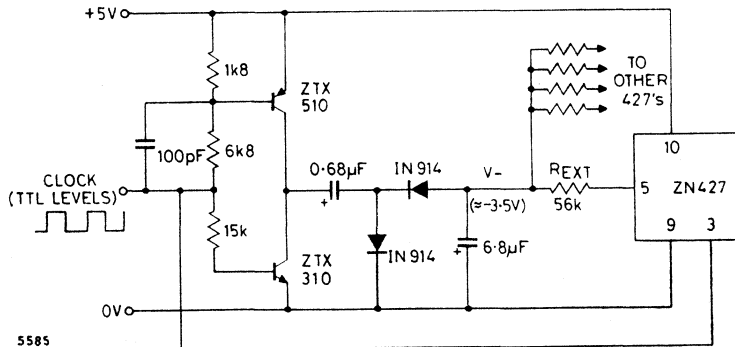
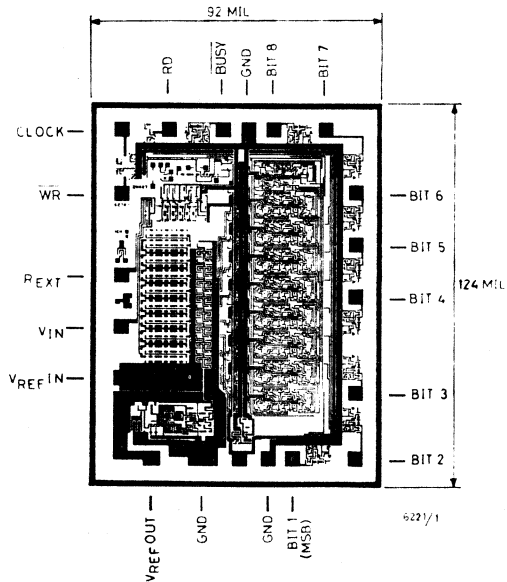
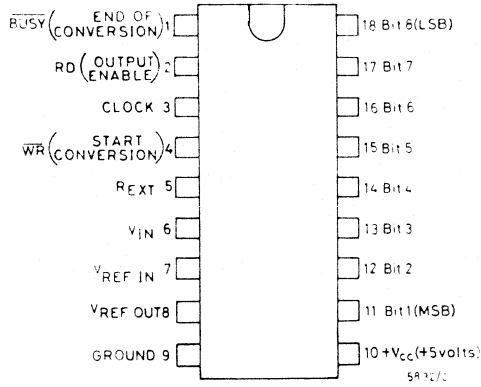

Fig. 17. Single 5 Volt Supply Operation

ZN427E-8/J-8

Pin Connections



Chip Dimensions and Layout

ZN427E-8/J-8

ORDERING INFORMATION

TYPE NUMBER	PACKAGE	OPERATING TEMP. RANGE
ZN427E-8	Plastic	0°C to +70°C
ZN427J-8	Ceramic	-55°C to +125°C

10-Bit Successive Approximation Monolithic A/D Converter
FEATURES

- 10, 9 and 8-Bit Accuracies
- 3 Operating Temperature Ranges
- 20 μ s Conversion Time Guaranteed
- Input Range as Desired
- ± 5 V Supplies, TTL/CMOS Compatible
- Parallel and Serial Outputs
- Bipolar Monolithic Construction

DESCRIPTION

The ZN432 range of successive approximation analogue to digital converters combine several innovations to provide this function on a fully monolithic silicon integrated circuit. The chip contains a current switching array using a matrix of diffused resistors (no trim required), successive approximation logic with TTL interfacing, 2.5V precision voltage reference with reference amplifier, and fast comparator with good overload recovery. The overall accuracy of the A-D system is sufficient to provide guaranteed monotonicity over the operating temperature range.

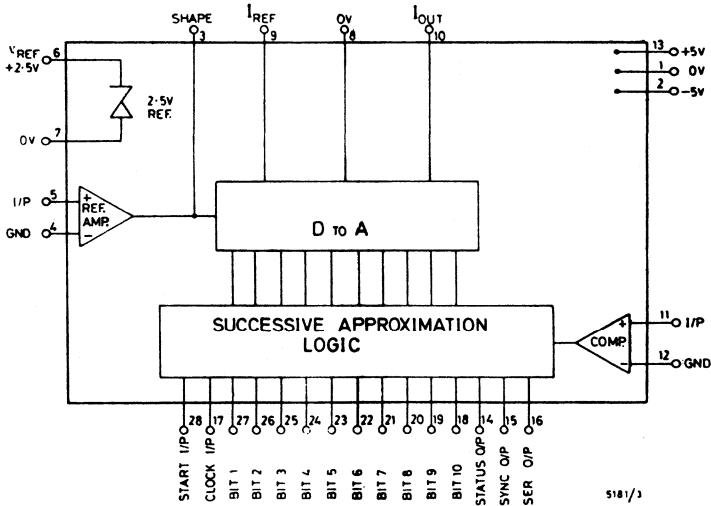
Fig. 1 – INTEGRATED CIRCUIT BLOCK DIAGRAM

ZN432 Series

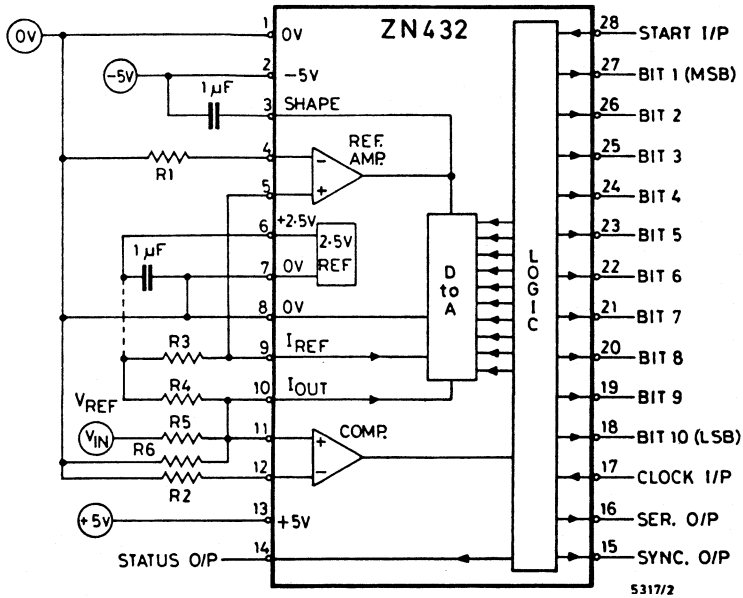

Fig. 2 – TYPICAL EXTERNAL COMPONENTS

ORDERING INFORMATION

Operating Temperature	10-bit accuracy	9-bit accuracy	8-bit accuracy	Package
-55 to +125°C	ZN432J-10	ZN432J-9	ZN432J-8	Ceramic
-40 to +85°C	ZN432BJ-10	ZN432BJ-9	ZN432BJ-8	Ceramic
0 to +70°C	ZN432CJ-10	ZN432CJ-9	ZN432CJ-8	Ceramic

ZN432 Series

ABSOLUTE MAXIMUM RATINGS

Supply Voltages	±7 volts
Logic Input Voltage	+V _{CC} and 0V
Storage Temperature Range	-55°C to +125°C

CHARACTERISTICS (at ±5V supplies and internal reference unless otherwise specified).

Parameter	Version	t _{amb} = +25°C			Over Spec. Temp. Range		Units	Conds.
		Min.	Typ.	Max.	Min.	Max.		
CONVERTER Accuracy (useful resolution)	ZN432J-10 ZN432BJ-10 ZN432CJ-10	10			10		Bits	Note 1
	ZN432J-9 ZN432BJ-9 ZN432CJ-9	9			9		Bits	
	ZN432J-8 ZN432BJ-8 ZN432CJ-8	8			8		Bits	
Non-linearity	All types			±0.5			LSB	
Differential non-linearity	All types		±0.5				LSB	Note 1
Operating temp. range	ZN432J-10 ZN432J-9 ZN432J-8				-55	+125	°C	
	ZN432BJ-10 ZN432BJ-9 ZN432BJ-8				-40	+85	°C	
	ZN432CJ-10 ZN432CJ-9 ZN432CJ-8				0	+70	°C	
D to A reference current, I _{REF} (pin 9)	All types	0.25		1.0	0.25	1.0	mA	Note 6
Conversion time	All types		15	20		20	µs	Note 2
Nominal analogue input range	All types	-2.5		+2.5			V	Note 3
Supply rejection	All types		0.1				% per V	
Gain error	All types		±0.05				%	Note 4

ZN432 Series

CHARACTERISTICS (continued)

Parameter	Version	$t_{amb} = +25^{\circ}\text{C}$			Over Spec. Temp. Range		Units	Conds.
		Min.	Typ.	Max.	Min.	Max.		
Gain temperature coefficient (Note 4)	ZN432J-10 ZN432BJ-10 ZN432CJ-10		10				ppm/ $^{\circ}\text{C}$	
	ZN432J-9 ZN432BJ-9 ZN432CJ-9 ZN432J-8 ZN432BJ-8 ZN432CJ-8		20				ppm/ $^{\circ}\text{C}$	
Zero temperature coefficient	ZN432J-10 ZN432BJ-10 ZN432CJ-10		7				ppm/ $^{\circ}\text{C}$ of FSR	
	ZN432J-9 ZN432BJ-9 ZN432CJ-9 ZN432J-8 ZN432BJ-8 ZN432CJ-8		15				ppm/ $^{\circ}\text{C}$ of FSR	
Supply voltage	All types	± 4.5	± 5	± 5.5	± 4.5	± 5.5	V	
Supply current	All types		35				mA	
Power consumption	All types		350				mW	
INTERNAL VOLTAGE REFERENCE Output voltage	All types		2.480				V	
Output voltage tolerance (Note 5)	ZN432J-10 ZN432BJ-10 ZN432CJ-10			± 1.5			%	
	ZN432J-9 ZN432BJ-9 ZN432CJ-9			± 2.0			%	
	ZN432J-8 ZN432BJ-8 ZN432CJ-8			± 5.0			%	
Slope impedance	All types		0.75				Ω	
Maximum Reference load current			± 2				mA	

ZN432 Series

CHARACTERISTICS (continued)

Parameter	Version	$t_{amb} = +25^{\circ}\text{C}$			Over Spec. Temp. Range		Units	Conditions
		Min.	Typ.	Max.	Min.	Max.		
LOGIC	All types							
High level input voltage		2.0			2.0		V	
Low level input voltage					0.8	0.8	V	
High level input current				7 50			μA μA	$V_S = \pm 5.5\text{V}$ $V_I = 2.4\text{V}$ $V_S = \pm 5.5\text{V}$ $V_I = 5.5\text{V}$
Low level input current				1			μA	$V_S = \pm 5.5\text{V}$ $V_I = 0.4\text{V}$
High level output voltage			2.4			2.4	V	$I_{load} = -40 \mu\text{A}$
Low level output voltage				0.4	0.4	V	$I_{load} = 1.6 \text{mA}$	

NOTE 1. No missing codes over full temperature range at resolution appropriate to accuracy.

NOTE 2. This corresponds to a maximum clock rate of 550 kHz based on 11 clock periods per conversion cycle (see timing diagram, page 2-42). This provides an update rate of 45 kHz.

NOTE 3. Single polarity and other input ranges may be provided by different input resistor values. (see page 2-41)

NOTE 4. Excluding reference.

NOTE 5. For typical temperature performance see Fig. 6

NOTE 6. The full scale D to A output current $I_{OUT} = 4$ times I_{REF} . For optimum performance $I_{REF} = 0.5 \text{mA}$.

ZN432 Series

TEST CIRCUIT

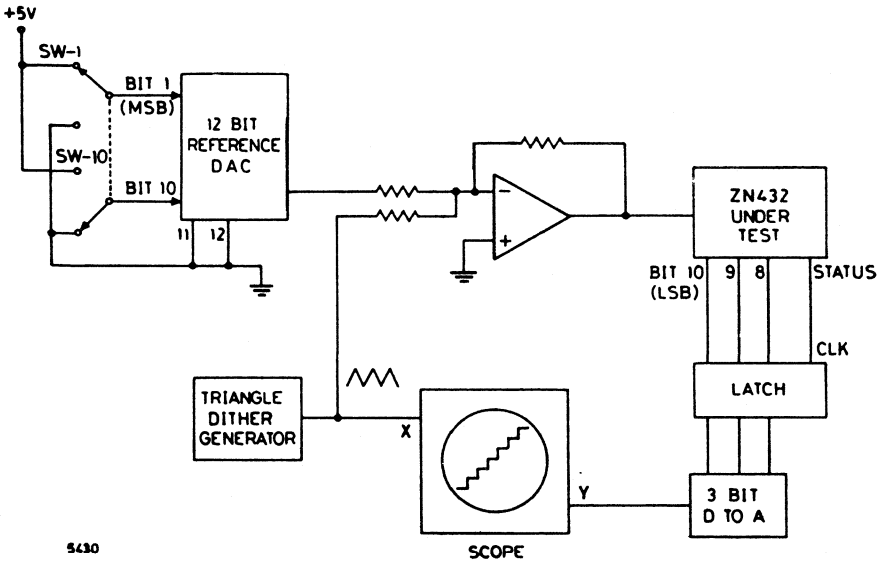

5430

Fig. 3 – DYNAMIC CROSSPLOT ACCURACY TEST

Switches SW-1 to SW-10 are set to the appropriate digital code to select the point on the characteristic to be displayed. For example, code 10000 00000 would select half full scale, i.e. the major transition.

The output from the dither generator (suggested peak to peak amplitude = $\pm 4 \times \text{L.S.B.}$) is used as the X deflection for the scope and is also superimposed on the analogue output from the reference D.A.C. in the summing amplifier. The resulting analogue signal including dither is used as V_{IN} for the ZN432 under test.

Bit 10, 9 and 8 outputs are fed to the inputs of a 3-bit D.A.C. of at least 6-bit accuracy and the analogue output used as the Y deflection for the scope. Differential non-linearity is shown by horizontal lines which are longer or shorter than the rest.

ZN432 Series

CALCULATION OF EXTERNAL RESISTORS (See Fig. 2)

1. R_3, R_4, R_5 can affect gain and offset stability and thus require to be of high quality.
2. R_1 and R_2 are to allow for the bias current of the reference amplifier and comparator, thus :

$$R_1 = R_3$$

And $R_2 =$ parallel combination of R_4, R_5 and R_6 .

3. I_{REF} should be 0.5 mA

Therefore

$$R_3 = \frac{V_{REF}}{0.5 \text{ mA}}$$

$I_{out \text{ FS}}$ is four times I_{REF} , i.e., 2 mA

4. Analysing the network yields the following :

$$R_4 = \frac{-V_{REF} R_5}{V_{in \text{ min}}}$$

$$R_5 = \frac{V_{in \text{ max}} - V_{in \text{ min}}}{I_{out \text{ FS}}}$$

Where $V_{in \text{ max}}$ is the voltage for the logic output to be all 1's.

$V_{in \text{ min}}$ is the voltage for the logic output to be all 0's.

5. R_6 should be chosen such that the parallel combination of R_4, R_5 and R_6 is about 1.25 k Ω as this determines the D to A time constant and hence conversion time.
6. The following is a table of values to give examples of the above equations.

$V_{in \text{ max}}$	$V_{in \text{ min}}$	V_{REF}	R_1^1	R_2^1	R_3	R_4	R_5	R_6^1
+2.5	-2.5	2.5	5 k Ω	1.25 k Ω	5 k Ω	2.5 k Ω	2.5 k Ω	∞
+2.5	-2.5	5*	10 k Ω	1.25 k Ω	10 k Ω	5 k Ω	2.5 k Ω	5 k Ω
+2.5	0	2.5	5 k Ω	1.25 k Ω	5 k Ω	∞	1.25 k Ω	∞
+5	0	2.5	5 k Ω	1.25 k Ω	5 k Ω	∞	2.5 k Ω	2.5 k Ω
+4	-2	2.5	5 k Ω	1.25 k Ω	5 k Ω	3.75 k Ω	3 k Ω	5 k Ω
+4	-2	12*	24 k Ω	1.25 k Ω	24 k Ω	3.75 k Ω	3 k Ω	5 k Ω
+10	-10	2.5	5 k Ω	1.25 k Ω	5 k Ω	2.5 k Ω	10 k Ω	3.33 k Ω

Note 1. Nearest preferred value may be used for R_1, R_2 and R_6

*Note 2. External reference

7. For setting up R_4 will adjust the offset.

R_3 will adjust the gain.

For unipolar operation where R_4 approaches ∞ and a zero adjustment is required, the following offset circuit is suggested in place of R_4 (Typical values only).

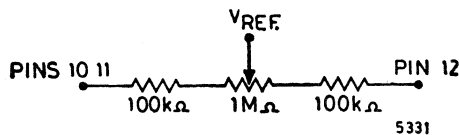

Fig. 4 - OFFSET CIRCUIT WITH UNIPOLAR OPERATION

ZN432 Series

TIMING DETAILS

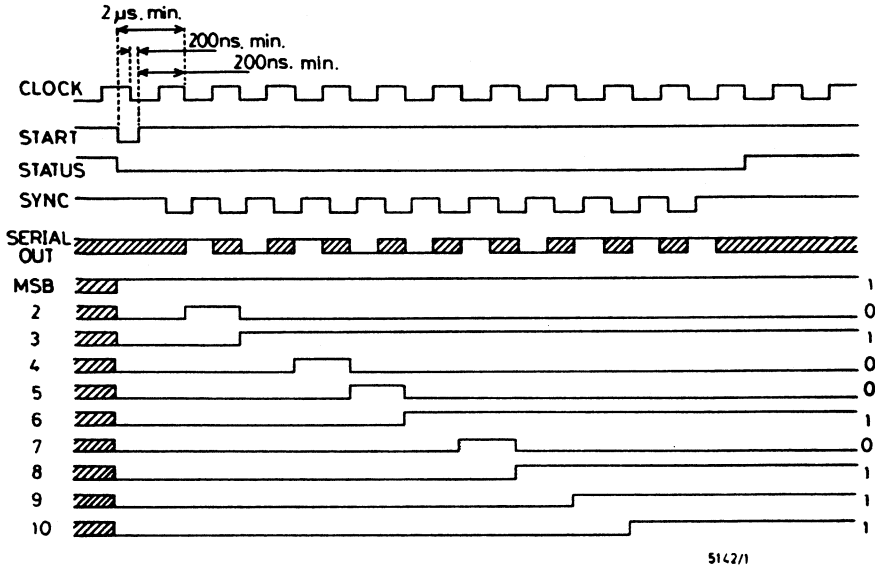

Fig. 5 – TIMING DIAGRAM

NOTES ON TIMING DIAGRAM

1. Conversion is initiated by a 'START' pulse which sets the MSB to 1 and all the other bits to 0.
2. The first active (negative going) edge of Clock after the trailing edge of the 'START' pulse should not occur until at least 2 μs after the leading edge of the 'START' pulse to allow for MSB settling.
3. A negative going edge of Clock must not occur within 200 ns either side of the trailing edge of the 'START' pulse.
4. As a special case of conditions (2) and (3) the 'START' pulse may be coincident with, and of the same duration as, a negative going clock pulse.
5. Serial data is available during conversion at the Serial Output.
Ten SYNC pulses are provided to facilitate data transmission.
The serial output data is valid on the positive going edge of the SYNC pulse.
6. Cross hatching indicates a 'don't care' condition or, in the case of serial output, invalid data.
7. The conversion sequence shown is for the digital word 1010010111.
8. The parallel output data is valid when the Status Output goes HIGH.

ZN432 Series

LOGIC CODING

Table 1. Unipolar Operation

Analogue Input Notes 1, 2	Digital Output Code	
	MSB	LSB
FS -1LSB	1111111111	
FS -2LSB	1111111110	
$\frac{1}{2}$ FS	1100000000	
$\frac{1}{2}$ FS +1LSB	1000000001	
$\frac{1}{2}$ FS	1000000000	
$\frac{1}{2}$ FS -1LSB	0111111111	
$\frac{1}{2}$ FS	0100000000	
1LSB	0000000001	
0	0000000000	

Table 2. Bipolar Operation

Analogue Input Notes 1, 2	Digital Output Code	
	MSB	LSB
+(FS -1LSB)	1111111111	
+(FS -2LSB)	1111111110	
+($\frac{1}{2}$ FS)	1100000000	
+(1LSB)	1000000001	
0	1000000000	
-(1LSB)	0111111111	
-($\frac{1}{2}$ FS)	0100000000	
-(FS-1LSB)	0000000001	
-FS	0000000000	

NOTES:

1. Analogue inputs shown are nominal centre values of code.
2. "FS" is full scale.

OFFSET AND GAIN SETTING

For unipolar, supply an input of $\frac{1}{2}$ LSB for transition 0000000000 to 0000000001, and of (full scale $-1\frac{1}{2}$ LSB) for transition 1111111111 to 1111111110.

For bipolar, supply an input of $-(\text{full scale } -\frac{1}{2} \text{ LSB})$ for transition 0000000000 to 0000000001, and of (full scale $-1\frac{1}{2}$ LSB) for transition 1111111111 to 1111111110.

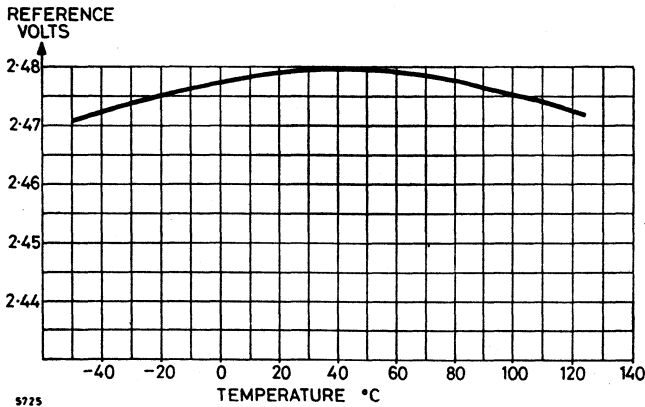
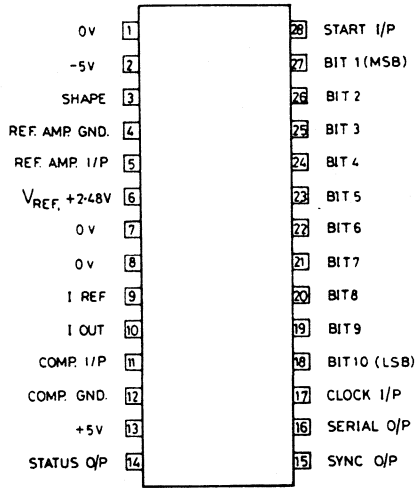

Fig. 6 - TYPICAL REFERENCE VOLTAGE v TEMPERATURE (ALL TYPES)

ZN432 Series

PIN CONNECTIONS



CHIP DIMENSIONS AND LAYOUT

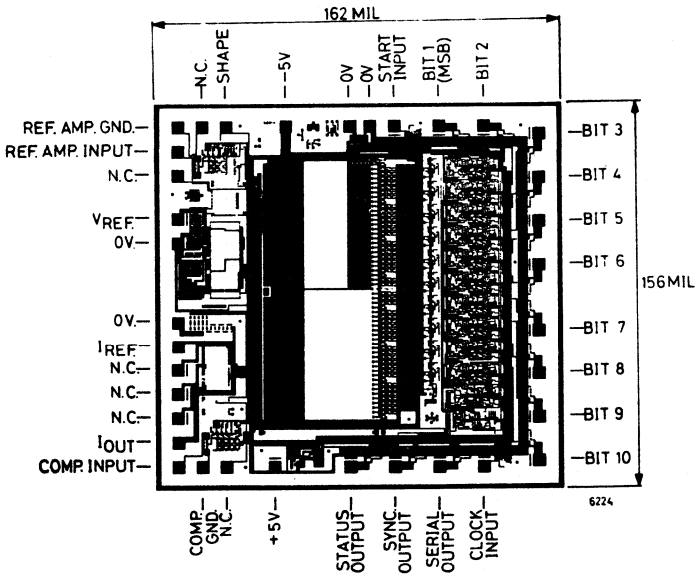

10-Bit Successive Approximation Monolithic A/D Converter
FEATURES

- 10 Bit Resolution
- No Missing Codes
- 20 μ s Conversion Time Guaranteed
- Input Range as Desired
- ± 5 V Supplies, TTL/CMOS Compatible
- Parallel and Serial Outputs
- Bipolar Monolithic Construction
- Low Cost Moulded Package

DESCRIPTION

The ZN432E successive approximation analogue to digital converter combines several innovations to provide this function on a fully monolithic silicon integrated circuit. The chip contains a current switching array using a matrix of diffused resistors (no trim required), successive approximation logic with TTL interfacing, 2.5V precision voltage reference with reference amplifier, and fast comparator with good overload recovery. The overall accuracy of the A-D system is sufficient to guarantee no missing codes over the operating temperature range.

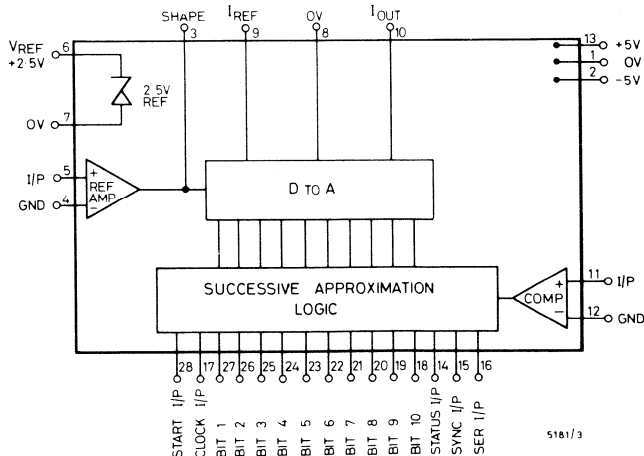
Fig. 1 – INTEGRATED CIRCUIT BLOCK DIAGRAM

ZN432E

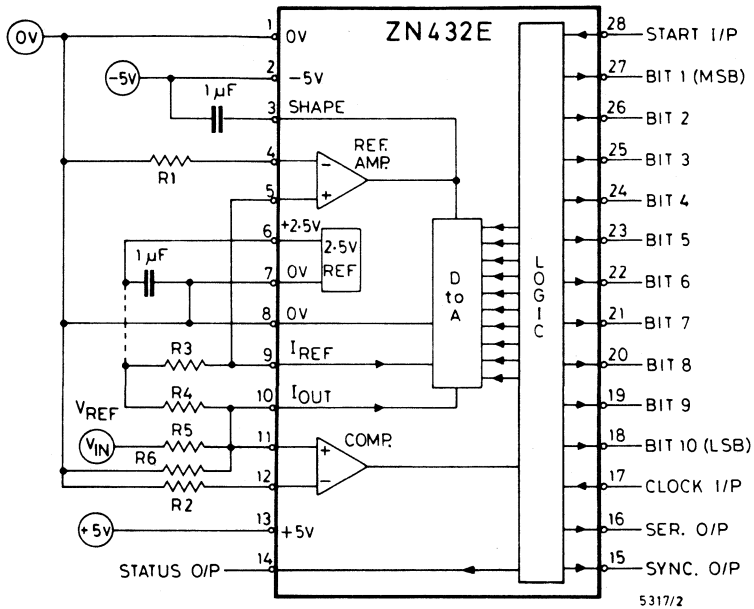

Fig. 2 – TYPICAL EXTERNAL COMPONENTS

ORDERING INFORMATION

TYPE No.	OPERATING TEMPERATURE RANGE	PACKAGE
ZN432E	0 to + 70°C	28 Pin Moulded DIL

ABSOLUTE MAXIMUM RATINGS

Supply Voltages	± 7 volts	
Logic Input Voltage	$+V_{CC}$ and OV	
				Min.	Max.
Operating Temperature	0°C	$+70^{\circ}\text{C}$
Storage Temperature	-55°C	$+125^{\circ}\text{C}$

ELECTRICAL CHARACTERISTICS

(Supply Voltage = $\pm 5\text{V}$, $T_{amb} = +25^{\circ}\text{C}$ unless otherwise stated)

Parameter	Min.	Typ.	Max.	Units	Conditions
CONVERTER					
Resolution	10	—	—	Bits	
Linearity Error	-1	0	+1	LSB	
Differential Linearity Error	-0.8	0	+1	LSB	Note 1
DAC Reference Current (I_{REF})	0.25	0.5	1	mA	Note 6
Conversion Time	—	15	20	μS	Note 2
Nominal Analogue Input Range	-2.5	—	+2.5	V	Note 3
Supply Rejection		0.1		% per V	
Gain Error		+0.05		%	Note 4
Gain Tempco		20		$\text{ppm}/^{\circ}\text{C}$	
Zero Tempco		15		$\text{ppm}/^{\circ}\text{C}$	
Supply Voltage	± 4.5	± 5	+5.5	V	
Supply Current		35		mA	
Power Consumption		350		mW	
INTERNAL VOLTAGE REFERENCE					
Output Voltage	2.38	2.46	2.54	V	Note 5
Slope Impedance		0.75			
Maximum Load Current		± 2		mA	

ZN432E

CHARACTERISTICS (continued)

Parameter	$t_{amb} = +25^{\circ}\text{C}$			Over Spec. Temp. Range		Units	Conditions
	Min.	Typ.	Max.	Min.	Max.		
LOGIC							
High level input voltage	2.0			2.0		V	
Low level input voltage			0.8		0.8	V	
High level input current		7				μA	$V_S = \pm 5.5\text{V}$ $V_I = 2.4\text{V}$
		50				μA	
Low level input current		1				μA	$V_S = \pm 5.5\text{V}$ $V_I = 5.5\text{V}$
High level output voltage	2.4			2.4		V	$I_{load} = -40 \mu\text{A}$
Low level output voltage			0.4		0.4	V	$I_{load} = 1.6 \text{ mA}$

NOTE 1. No missing codes over full temperature range at resolution appropriate to accuracy.

NOTE 2. This corresponds to a maximum clock rate of 550 kHz based on 11 clock periods per conversion cycle (see timing diagram, 2-50). This provides an update rate of 45 kHz.

NOTE 3. Single polarity and other input ranges may be provided by different input resistor values. (See page 2-49)

NOTE 4. Excluding reference.

NOTE 5. For typical temperature performance see Fig. 5

NOTE 6. The full scale D to A output current $I_{OUT} = 4$ times I_{REF} . For optimum performance $I_{REF} = 0.5 \text{ mA}$.

CALCULATION OF EXTERNAL RESISTORS (See Fig. 2)

1. R_3, R_4, R_5 can affect gain and offset stability and thus require to be of high quality.
2. R_1 and R_2 are to allow for the bias current of the reference amplifier and comparator, thus:

$$R_1 = R_3$$

And $R_2 =$ parallel combination of $R_4, R_5,$ and R_6 .

3. I_{REF} should be 0.5mA

Therefore

$$R_3 = \frac{V_{REF}}{0.5 \text{ mA}}$$

$I_{out FS}$ is four times I_{REF} , i.e., 2 mA

4. Analysing the network yields the following:

$$R_4 = \frac{-V_{REF} R_5}{V_{in \text{ min}}}$$

$$R_5 = \frac{V_{in \text{ max}} - V_{in \text{ min}}}{I_{out FS}}$$

Where $V_{in \text{ max}}$ is the voltage for the logic output to be all 1's.

$V_{in \text{ min}}$ is the voltage for the logic output to be all 0's.

5. R_6 should be chosen such that the parallel combination of R_4, R_5 and R_6 is about 1.25 k Ω as this determines the D to A time constant and hence conversion time.
6. The following is a table of values to give examples of the above equations.

$V_{in \text{ max}}$	$V_{in \text{ min}}$	V_{REF}	R_1^1	R_2^1	R_3	R_4	R_5	R_6^1
+2.5	-2.5	2.5	5 k Ω	1.25 k Ω	5 k Ω	2.5 k Ω	2.5 k Ω	∞
+2.5	-2.5	5*	10 k Ω	1.25 k Ω	10 k Ω	5 k Ω	2.5 k Ω	5 k Ω
+2.5	0	2.5	5 k Ω	1.25 k Ω	5 k Ω	∞	1.25 k Ω	∞
+5	0	2.5	5 k Ω	1.25 k Ω	5 k Ω	∞	2.5 k Ω	2.5 k Ω
+4	-2	2.5	5 k Ω	1.25 k Ω	5 k Ω	3.75 k Ω	3 k Ω	5 k Ω
+4	-2	12*	24 k Ω	1.25 k Ω	24 k Ω	3.75 k Ω	3 k Ω	5 k Ω
+10	-10	2.5	5 k Ω	1.25 k Ω	5 k Ω	2.5 k Ω	10 k Ω	3.33 k Ω

Note 1. Nearest preferred value may be used for R_1, R_2 and R_6

Note 2. External reference.

7. For setting up R_4 will adjust the offset.

R_3 will adjust the gain.

For unipolar operation where R_4 approaches ∞ and a zero adjustment is required, the following offset circuit is suggested in place of R_4 (Typical values only).

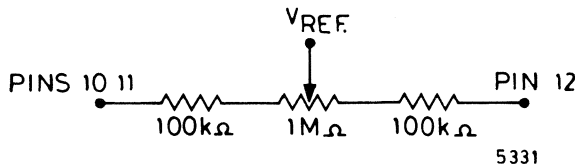

Fig. 3 – OFFSET CIRCUIT WITH UNIPOLAR OPERATION

ZN432E

TIMING DETAILS

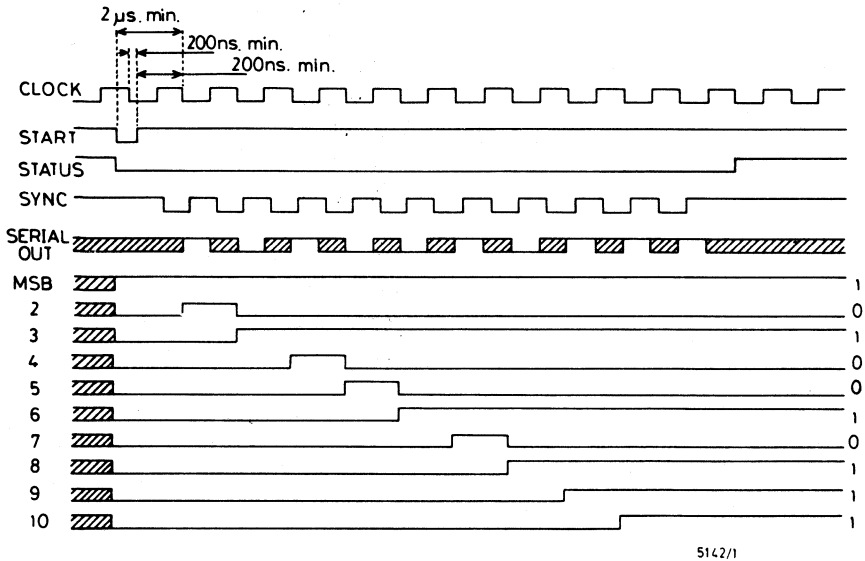

Fig. 4 – TIMING DIAGRAM

NOTES ON TIMING DIAGRAM

1. Conversion is initiated by a 'START' pulse which sets the MSB to 1 and all the other bits to 0.
2. The first active (negative going) edge of Clock after the trailing edge of the 'START' pulse should not occur until at least 2 μs after the leading edge of the 'START' pulse to allow for MSB settling.
3. A negative going edge of Clock must not occur within 200 ns either side of the trailing edge of the 'START' pulse.
4. As a special case of conditions (2) and (3) the 'START' pulse may be coincident with, and of the same duration as, a negative going clock pulse.
5. Serial data is available during conversion at the Serial Output.
Ten SYNC pulses are provided to facilitate data transmission.
The serial output data is valid on the positive going edge of the SYNC pulse.
6. Cross hatching indicates a 'don't care' condition or, in the case of serial output, invalid data.
7. The conversion sequence shown is for the digital word 1010010111.
8. The parallel output data is valid when the Status Output goes HIGH.

LOGIC CODING

Table 1. Unipolar Operation

Analogue Input Notes 1, 2	Digital Output Code	
	MSB	LSB
FS - 1LSB	1111111111	
FS - 2LSB	1111111110	
¼ FS	1100000000	
½ FS + 1LSB	1000000001	
½ FS	1000000000	
½ FS - 1LSB	0111111111	
¼ FS	0100000000	
1 LSB	0000000001	
0	0000000000	

Table 2. Bipolar Operation

Analogue Input Notes 1, 2	Digital Output Code	
	MSB	LSB
+(FS - 1LSB)	1111111111	
+(FS - 2LSB)	1111111110	
+½ FS	1100000000	
+(1LSB)	1000000001	
0	1000000000	
-(1LSB)	0111111111	
-½ FS	0100000000	
-(FS - 1LSB)	0000000001	
-FS	0000000000	

NOTES:

1. Analogue inputs shown are nominal centre values of code.
2. "FS" is full scale.

OFFSET AND GAIN SETTING

For unipolar, supply an input of ½ LSB for transition 0000000000 to 0000000001, and of (full scale - 1½ LSB) for transition 1111111111 to 1111111110.

For bipolar, supply an input of -(full scale - ½ LSB) for transition 0000000000 to 0000000001, and of (full scale - 1½ LSB) for transition 11111111111 to 11111111110.

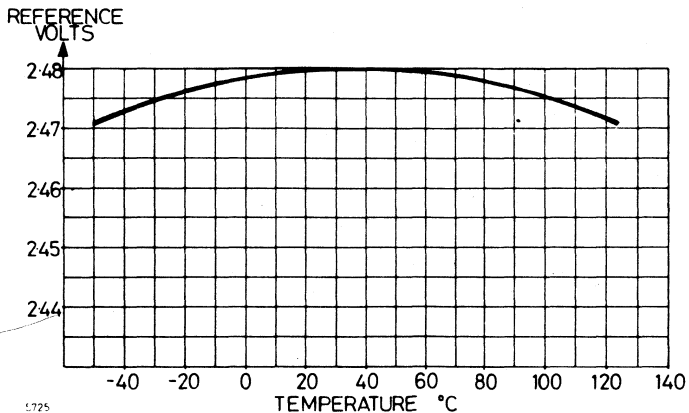

Fig. 5 - TYPICAL REFERENCE VOLTAGE v TEMPERATURE

ZN432E

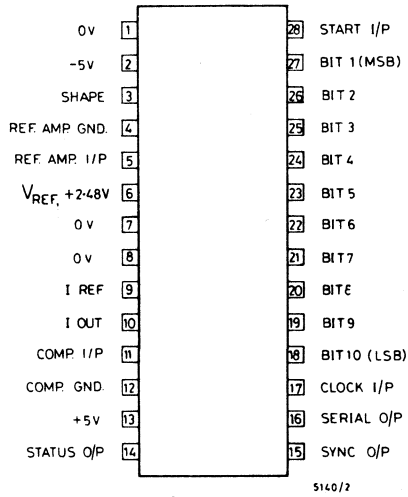

Fig. 6 – PIN CONNECTIONS

10-Bit Tracking Monolithic A/D Converter
FEATURES

- 10, 9 and 8-Bit Accuracies
- 3 Operating Temperature Ranges
- 1 μ s Conversion Time (Assuming Continuous Tracking)
- Input Range as Desired
- ± 5 V Supplies, TTL/CMOS Compatible
- Parallel and Serial Outputs
- Bipolar Monolithic Construction

DESCRIPTION

The ZN433 range of tracking analogue to digital converters combines several innovations to provide this function on a fully monolithic silicon integrated circuit. The chip contains a current switching array using a matrix of diffused resistors (no trim required), tracking logic with TTL interfacing, 2.5V precision voltage reference with reference amplifier, and fast window comparator with good overload recovery. At a resolution appropriate to the accuracy specification, no missing codes are obtained over the full temperature range.

The tracking principle ensures continuous up to date conversion data. This is suitable for single channel conversion, e.g. digital transducers, and often obviates the need for sample and hold.

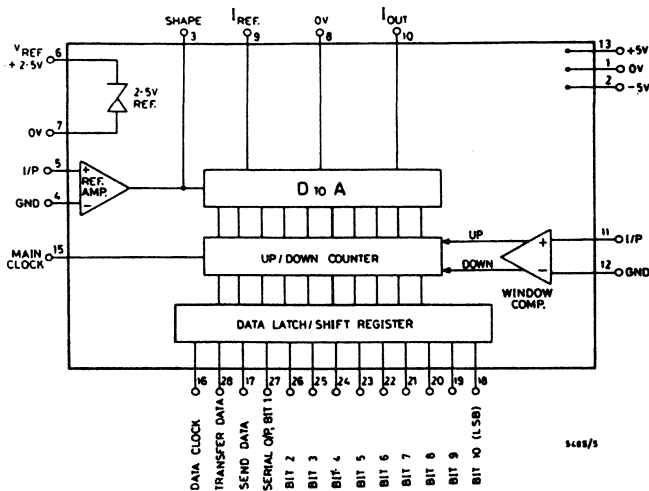
Fig. 1 - SYSTEM DIAGRAM

ZN433 Series

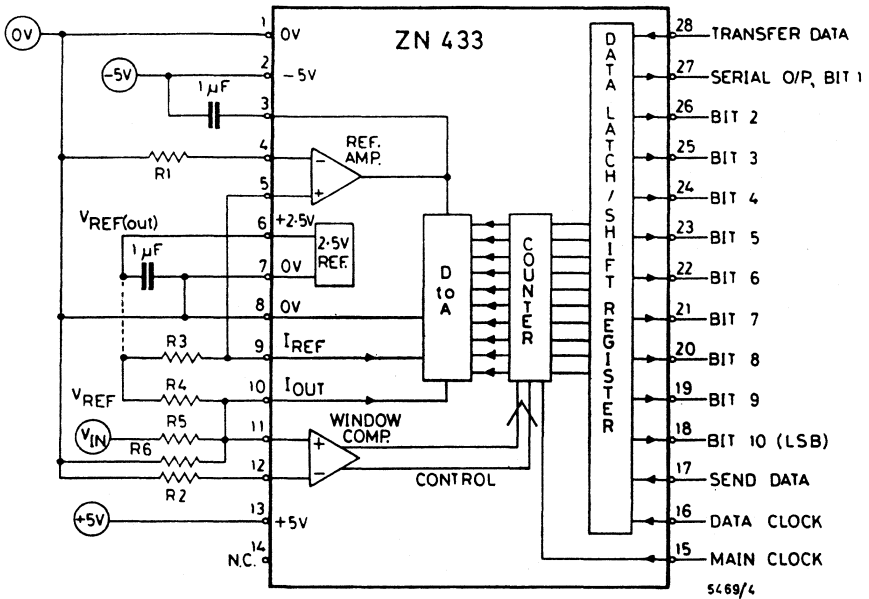

Fig. 2 – TYPICAL EXTERNAL COMPONENTS

See page 93 for calculation of resistor values. When the internal reference is used, $V_{REF(out)}$ (pin 6) is connected to R3 and R4 as shown. An external reference may also be used, which for ratiometric operation can vary by $\pm 20\%$ of nominal.

ORDERING INFORMATION

Operating Temperature	10-bit accuracy	9-bit accuracy	8-bit accuracy	Package
-55 to +125°C	ZN433J-10	ZN433J-9	ZN433J-8	Ceramic Ceramic Ceramic
-40 to +85°C	ZN433BJ-10	ZN433BJ-9	ZN433BJ-8	
0 to +70°C	ZN433CJ-10	ZN433CJ-9	ZN433CJ-8	

ZN433 Series

ABSOLUTE MAXIMUM RATINGS

Supply Voltages ± 7 volts
 Logic Input Voltage $+V_{CC}$ and 0V
 Storage Temperature Range -55°C to $+125^{\circ}\text{C}$

CHARACTERISTICS (at $\pm 5\text{V}$ supplies and internal reference unless otherwise specified).

Parameter	Version	$T_{amb} = +25^{\circ}\text{C}$			Over Spec. Temp. Range		Units	Conds.	
		Min.	Typ.	Max.	Min.	Max.			
CONVERTER									
Accuracy (useful resolution)	ZN433J-10 ZN433BJ-10 ZN433CJ-10	10			10		Bits	Note 1	
	ZN433J-9 ZN433BJ-9 ZN433CJ-9		9			9			Bits
	ZN433J-8 ZN433BJ-8 ZN433CJ-8			8					
Non-linearity	All types				± 0.5		LSB		
Differential non-linearity	All types		± 0.5			LSB	Note 1		
Operating temp. range	ZN433J-10 ZN433J-9 ZN433J-8				-55	+125	$^{\circ}\text{C}$		
	ZN433BJ-10 ZN433BJ-9 ZN433BJ-8				-40	+85	$^{\circ}\text{C}$		
	ZN433CJ-10 ZN433CJ-9 ZN433CJ-8				0	+70	$^{\circ}\text{C}$		
D to A reference current, I_{REF} (pin 9)	All types	0.8		1.2	0.8	1.2	mA	Note 2	
Max. Clock Rate	All types	1	1.2		1		MHz	Note 3	
Nominal analogue input range	All types	-2.5		+2.5			V	Note 4	
Supply rejection	All types		0.1				% per V		

ZN433 Series

CHARACTERISTICS (continued)

Parameter	Version	$T_{amb} = +25^{\circ}\text{C}$			Over Spec. Temp. Range		Units	Conds.
		Min.	Typ.	Max.	Min.	Max.		
Gain temperature coefficient (Note 5)	ZN433J-10 ZN433BJ-10 ZN433CJ-10		10				ppm/ $^{\circ}\text{C}$	
	ZN433J-9 ZN433BJ-9 ZN433CJ-9 ZN433J-8 ZN433BJ-8 ZN433CJ-8		20				ppm/ $^{\circ}\text{C}$	
Zero temperature coefficient	ZN433J-10 ZN433BJ-10 ZN433CJ-10		7				ppm/ $^{\circ}\text{C}$ of FSR	
	ZN433J-9 ZN433BJ-9 ZN433CJ-9 ZN433J-8 ZN433BJ-8 ZN433CJ-8		15				ppm/ $^{\circ}\text{C}$ of FSR	
Supply voltage	All types	± 4.5	± 5	± 5.5	± 4.5	± 5.5	V	
Supply current	All types		50				mA	
Power consumption	All types		500				mW	
INTERNAL VOLTAGE REFERENCE Output voltage	All types		2.480				V	
Output voltage tolerance (Note 6)	ZN433J-10 ZN433BJ-10 ZN433CJ-10			± 1.5			%	
	ZN433J-9 ZN433BJ-9 ZN433CJ-9			± 2.0			%	
	ZN433J-8 ZN433BJ-8 ZN433CJ-8			± 5.0			%	
Slope impedance	All types		0.75				Ω	
Maximum reference load current			± 4				mA	

ZN433 Series

CHARACTERISTICS (continued)

Parameter	Version	$T_{amb} = +25^{\circ}\text{C}$			Over Spec. Temp. Range		Units	Conditions
		Min.	Typ.	Max.	Min.	Max.		
LOGIC	All types							
High level input voltage		2.0			2.0		V	
Low level input voltage				0.8		0.8	V	
High level input current				7			μA	$V_S = \pm 5.5\text{V}$ $V_I = 2.4\text{V}$
				50			μA	$V_S = \pm 5.5\text{V}$ $V_I = 5.5\text{V}$
Low level input current				1			μA	$V_S = \pm 5.5\text{V}$ $V_I = 0.4\text{V}$
High level output voltage		2.4			2.4	V	$I_{load} = -40 \mu\text{A}$	
Low level output voltage				0.4	0.4	V	$I_{load} = 1.6 \text{ mA}$	

NOTE 1. No missing codes over full temperature range at resolution appropriate to accuracy.

NOTE 2. The full scale D to A output current $I_{out} = 4$ times I_{REF} . For optimum performance $I_{REF} = 1.0 \text{ mA}$.

NOTE 3. For main clock waveform see Fig. 5, 2-60. Input signals which do not change by more than $1 \text{ LSB}/\mu\text{s}$ may be tracked continuously without the need for a sample and hold. This corresponds to a full scale bandwidth of 300 Hz. Higher frequencies may be tracked if the amplitude is reduced, e.g. the half full scale bandwidth is 600 Hz.

NOTE 4. Single polarity and other input ranges may be provided by different input resistor values (see 2-59)

NOTE 5. Excluding reference.

NOTE 6. For typical temperature performance see Fig. 6

ZN433 Series

TEST CIRCUIT

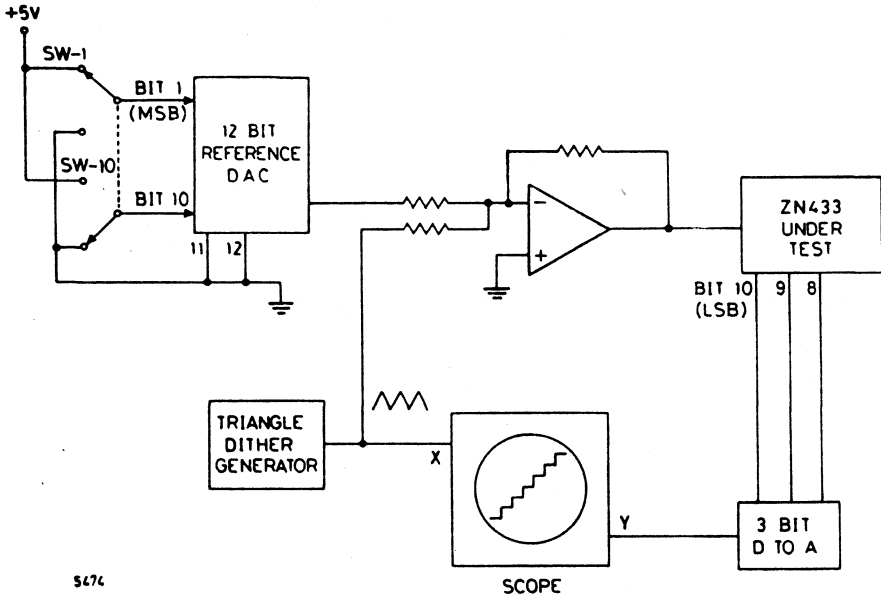

547c

Fig. 3 - DYNAMIC CROSSPLOT ACCURACY TEST

Switches SW-1 to SW-10 are set to the appropriate digital code to select the point on the characteristic to be displayed. For example, code 10000 00000 would select half full scale, i.e. the major transition.

The output from the dither generator (suggested peak to peak amplitude = $\pm 4 \times \text{L.S.B.}$) is used as the X deflection for the scope and is also superimposed on the analogue output from the reference D.A.C. in the summing amplifier. The resulting analogue signal including dither is used as V_{IN} for the ZN433 under test.

Bit 10, 9 and 8 outputs are fed to the inputs of a 3 bit D.A.C. of at least 6 bit accuracy and the analogue output used as the Y deflection for the scope. Differential non-linearity is shown by horizontal lines which are longer or shorter than the rest.

ZN433 Series

CALCULATION OF EXTERNAL RESISTORS (See Fig. 2)

1. R_3, R_4, R_5 can affect gain and offset stability and thus require to be of high quality.
2. R_1 and R_2 are to allow for the bias current of the reference amplifier and comparator which both operate in a virtual earth mode. Thus: $R_1 = R_3$
And $R_2 =$ parallel combination of R_4, R_5 and R_6 .
3. I_{REF} should be 1.0 mA, though it may be varied from 0.8 mA to 1.2 mA,

Therefore
$$R_3 = \frac{V_{REF}}{1.0 \text{ mA}}$$

$I_{out FS}$ is four times I_{REF} , i.e., 4 mA (I_{out} for zero reading is 0 mA).

4. Analysing the network yields the following:

$$R_4 = \frac{-V_{REF} R_5}{V_{in \text{ min}}}$$

$$R_5 = \frac{V_{in \text{ max}} - V_{in \text{ min}}}{I_{out \text{ FS}}}$$

Where $V_{in \text{ max}}$ is the voltage for the logic output to be all 1's.

$V_{in \text{ min}}$ is the voltage for the logic output to be all 0's.

5. R_6 should be chosen such that the parallel combination of R_4, R_5 and R_6 is about 625Ω as this determines the D to A time constant and hence conversion time.
6. The following is a table of values to give examples of the above equations.

$V_{in \text{ max}}$	$V_{in \text{ min}}$	V_{REF}	R_1^1	R_2^1	R_3	R_4	R_5	R_6^1
+2.5	-2.5	2.5	2.5 k Ω	625 Ω	2.5 k Ω	1.25 k Ω	1.25 k Ω	∞
+2.5	-2.5	5*	5 k Ω	625 Ω	5 k Ω	2.5 k Ω	1.25 k Ω	2.5 k Ω
+2.5	0	2.5	2.5 k Ω	625 Ω	2.5 k Ω	∞	625 Ω	∞
+5	0	2.5	2.5 k Ω	625 Ω	2.5 k Ω	∞	1.25 k Ω	1.25 k Ω
+4	-2	2.5	2.5 k Ω	625 Ω	2.5 k Ω	1.875 k Ω	1.5 k Ω	2.5 k Ω
+4	-2	12*	12 k Ω	625 Ω	12 k Ω	1.875 k Ω	1.5 k Ω	2.5 k Ω
+10	-10	2.5	2.5 k Ω	625 Ω	2.5 k Ω	1.25 k Ω	5 k Ω	1.67 k Ω

Note 1. Nearest preferred value may be used for R_1, R_2 and R_6

*Note 2. External reference

7. For setting up: R_4 will adjust the offset.

R_3 will adjust the gain.

For unipolar operation where R_4 approaches ∞ and a zero adjustment is required, the following offset circuit is suggested in place of R_4 (Typical values only).

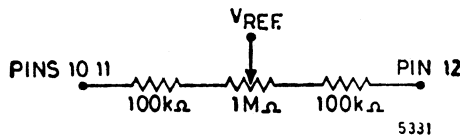

Fig. 4 – OFFSET CIRCUIT WITH UNIPOLAR OPERATION

ZN433 Series

LOGIC DETAILS

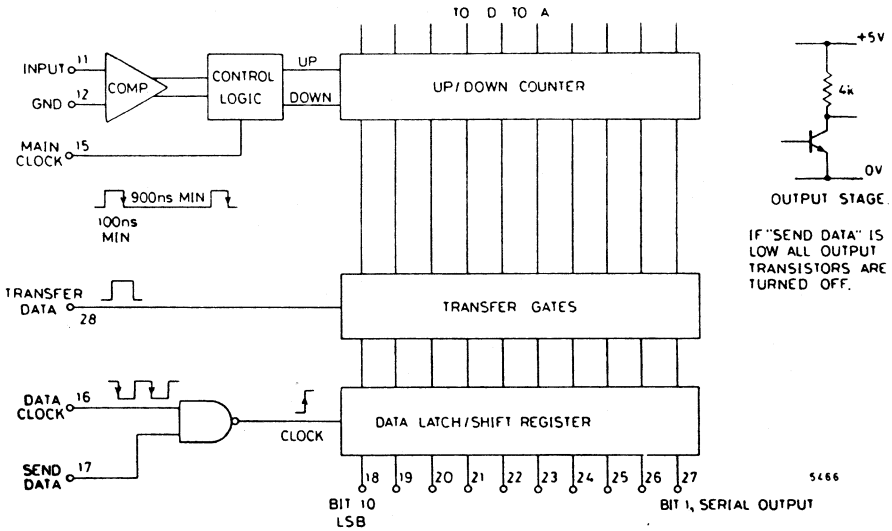

Fig. 5 – LOGIC SYSTEM

NOTES ON LOGIC DIAGRAM

1. The Window Comparator and Control Logic determine whether the Counter will clock up or down or keep the same value on an active (negative going) edge of the Main Clock.
2. Parallel data from the Up/Down Counter will be loaded into the output Data Latch/Shift Register when the TRANSFER DATA input is HIGH. TRANSFER DATA should not be taken HIGH until 150 ns after the MAIN CLOCK edge and should go LOW before the next MAIN CLOCK edge. The minimum TRANSFER DATA pulse width is 50 ns.
If TRANSFER DATA is held permanently HIGH then the Counter outputs will appear directly at the bit outputs.
3. Serial output data (MSB first) can be obtained from the MSB output (Pin 27) by applying a DATA CLOCK (Pin 16, 1 MHz maximum, 100 ns minimum pulse width).
4. A LOW on SEND DATA (Pin 17) disables the DATA CLOCK and turns off all the output transistors so that all the bit outputs are HIGH (see diagram of output).

ZN433 Series

LOGIC CODING

Table 1. Unipolar Operation

Analogue Input Notes 1, 2	Digital Output Code	
	MSB	LSB
FS -1LSB	1111111111	
FS -2LSB	1111111110	
$\frac{3}{4}$ FS	1100000000	
$\frac{1}{2}$ FS +1LSB	1000000001	
$\frac{1}{2}$ FS	1000000000	
$\frac{1}{4}$ FS -1LSB	0111111111	
$\frac{1}{4}$ FS	0100000000	
1LSB	0000000001	
0	0000000000	

Table 2. Bipolar Operation

Analogue Input Notes 1, 2	Digital Output Code	
	MSB	LSB
+(FS -1LSB)	1111111111	
+(FS -2LSB)	1111111110	
$+(\frac{1}{2}$ FS)	1100000000	
$+(1$ LSB)	1000000001	
0	1000000000	
-(1LSB)	0111111111	
$-(\frac{1}{2}$ FS)	0100000000	
-(FS -1LSB)	0000000001	
-FS	0000000000	

NOTES:

1. Analogue inputs shown are nominal centre values of code.
2. "FS" is full scale.

OFFSET AND GAIN SETTING

For unipolar, supply an input of $\frac{1}{2}$ LSB for transition 000000000 to 000000001, and of (full scale -1 $\frac{1}{2}$ LSB) for transition 111111111 to 111111110.

For bipolar, supply an input of -(full scale - $\frac{1}{2}$ LSB) for transition 000000000 to 000000001, and of (full scale -1 $\frac{1}{2}$ LSB) for transition 111111111 to 111111110.

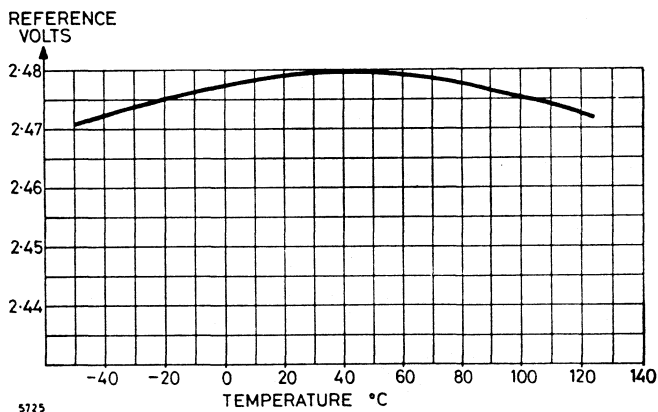
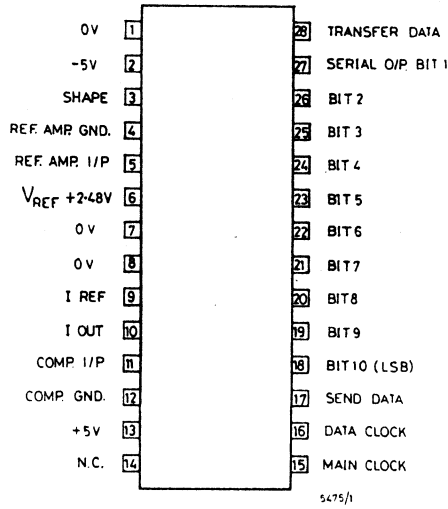

Fig. 6 - TYPICAL REFERENCE VOLTAGE v TEMPERATURE (ALL TYPES)

ZN433 Series

PIN CONNECTIONS



CHIP DIMENSIONS AND LAYOUT

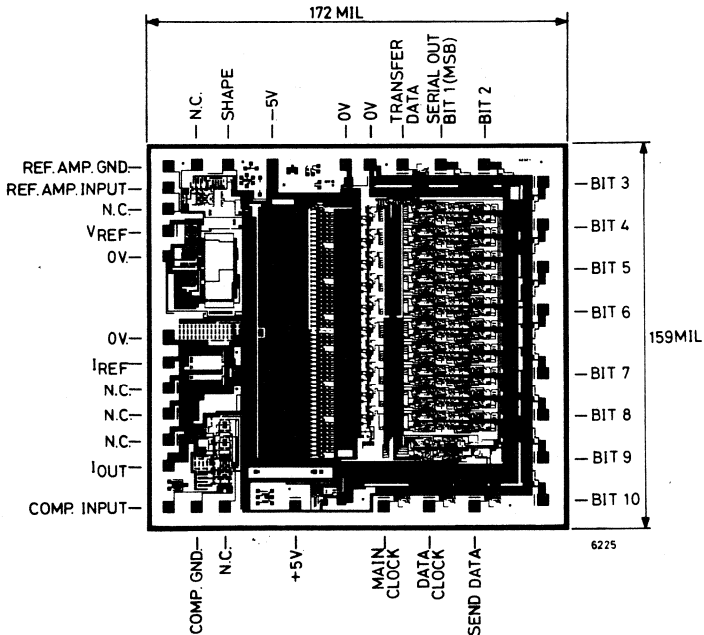

Ultra Fast Monolithic Video A/D Converter
ADVANCE PRODUCT INFORMATION

Some parametric limits may be subject to change

Features

- 18 million conversions per second
- 6 bit resolution
- Expandable to 7 or 8 bits
- $\pm 1/2$ LSB linearity
- No sample-and-hold required
- Unipolar or bipolar input range
- TTL compatible
- $\pm 5V$ supply
- 1W power dissipation

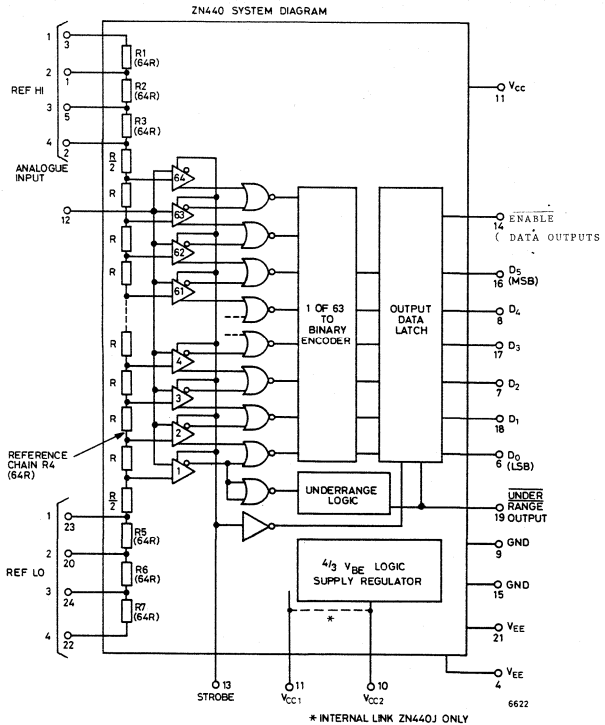
Description

The ZN440 is a high-speed, 6 bit parallel A to D converter capable of digitising an analogue signal at rates from DC to 18 megasamples per second. AC signals with frequency components up to several MHz can accurately be digitised without the need for an external sample-and-hold circuit. Two or four ZN440's can be stacked to give a 7- or 8-bit converter with a minimum of external components.

Applications include high-speed data acquisition, video and radar data conversion, digital signal storage and image processing.

ZN440

Absolute Maximum Ratings

V_{CC}0 to +5.5V
 V_{EE}0 to -5.5V
 Inputs, digital.....0 to +5V
 Input, Analogue Signal.....-4.2V to +1.4V
 Maximum Reference Chain Current.....60mA
 Operating Temperature Range.....0 to +70°
 Storage Temperature Range.....-55°C to +125°C
 Electrical Characteristics (\pm 5V supply, T_{amb} = +25°C unless
 otherwise stated. Output load as figure 8).

PARAMETER	MIN	TYP	MAX	UNITS	CONDITIONS
POWER SUPPLY					
Recommended Supply Voltage					
V_{CC}	+4.75	+5	+5.25	volts	
V_{EE}	-4.75	-5	-5.25	volts	
Supply Current					
I_{CC}	-	95	150	mA	
I_{EE}	-	55	80	mA	
ANALOGUE					
Reference Voltage Across	-	-	1	volts	0 to +70°C
Comparator Chain $-V_{REF}$					
Reference Resistor R	-	0.3	-	ohms	
Resolution	6	-	-	bits	
Linearity Error	-	-	± 0.5	LSB	$V_{REF} = 1V$
	-	-	± 0.5	LSB	$V_{REF} = 0.5V$
Input Signal Range	-4.0	-	+0.5	volts	
Input Resistance, R_{IN}	8	-	-	K	$V_{REF} = 1V$
Input Capacitance, C_{IN}	-	-	100	pF	
Input Bias Current I_{BIAS}	-	-	90	μA	

Continued overleaf.....

Electrical Characteristics cont/d

PARAMETER	MIN	TYP	MAX	UNITS	CONDITIONS
DIGITAL (static)					
High Level Input Voltage, V_{IN}	1.4	-	-	volts	
Low Level Input Voltage, V_{IL}	-	-	0.8	volts	
High Level Input Current, I_{IH}	-	-	-	μA)
Low Level Input Current, I_{IL}	-	-	-	mA) (Note 2)
High Level Output Voltage, V_{OH}	2.4	-	-	volts	$I_{OH} = 400\mu A$
Low Level Output Voltage, V_{OL}	-	-	0.4	volts	$I_{OL} = -1.6 mA$
DYNAMIC					
Convert Pulse Width $-T_H$	20	-	-	ns	(Note 1)
Strobe Low Period $-T_L$	-	40	-	ns	
Maximum Sampling Frequency	16	18	-	MHz	
Digital Output Delays					
t_1	50	55	100	ns	
t_2	90	95	120	ns	
t_3	50	55	80	ns	
t_4	65	70	100	ns	
Aperture Delay $-T_{ad}$	-	20	-	ns	
Transient Response (Recover from full- scale step input)	-	15	-	ns	
Output Enable Delays					
T_{D1}	7	8	15	ns	
T_{D2}	27	28	15	ns	
T_{E1}	22	25	35	ns	
T_{E2}	35	40	80	ns	

ZN440

Note 1

Although the STROBE input is TTL compatible, for maximum speed the HIGH Level should be at least +3V. If a normal totem-pole TTL output is used to drive pin 13 then a 1k pullup should be used to ensure this.

Note 2

The Output ENABLE input consists of a high speed buffer circuit which can be driven from a standard TTL totem-pole output. if other TTL inputs are to be driven by the same signal the ZN440 Output ENABLE input should be buffered owing to its input loading characteristics.

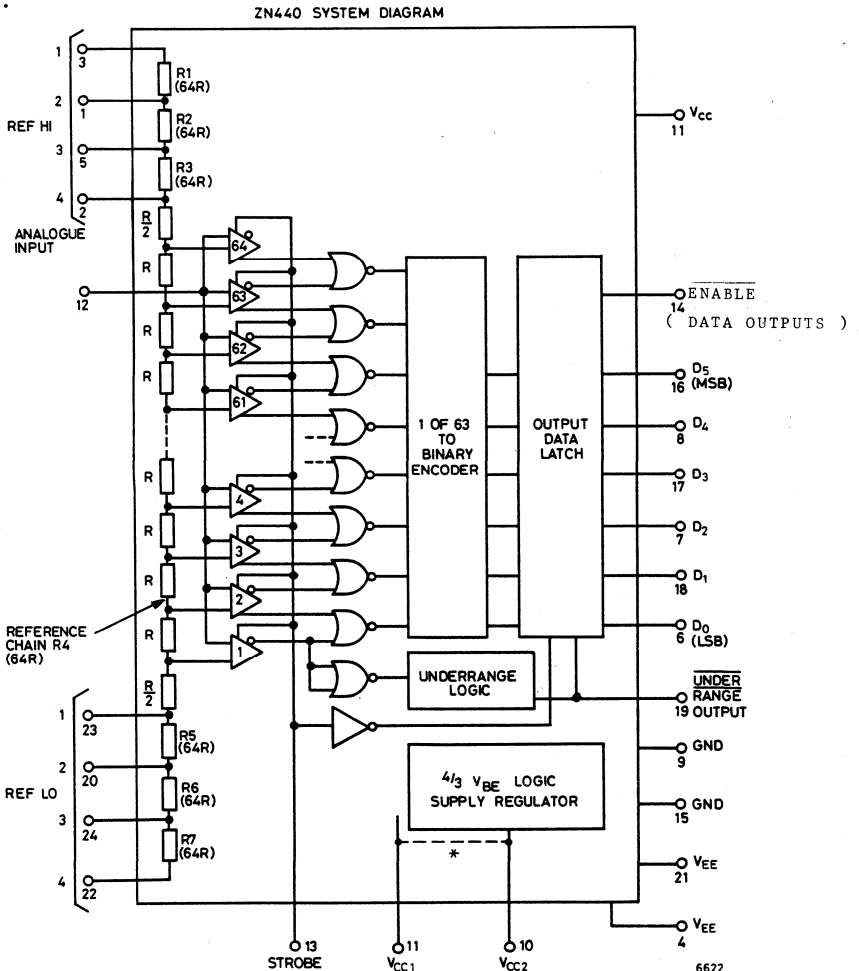

* INTERNAL LINK ZN440J ONLY

SYSTEM DESCRIPTION

The ZN440 is an ultra-high speed parallel (flash) A to D converter comprising an array of 64 strobed comparators and encoding logic. A reference voltage applied across a tapped resistor chain defines 63 quantisation levels plus overrange and underrange, one input of each comparator being connected to the resistor string, whilst the other inputs are commoned and connected to the analogue input. When an analogue input is applied all the comparators whose reference voltage is less than the analogue input will change state, i.e. if the input voltage is $\frac{n}{64} V_{REF}$ then n comparators will have tripped. The comparator outputs are decoded into 1 of 64 format by NOR gates and then re-encoded into binary by a high-speed ROM.

STROBE INPUT

The STROBE input controls the comparators and the output data latch. Whilst STROBE is high the comparators are sampling the input signal, the results of the last sample are stored in the latch and are available as the output data.

When STROBE goes low the comparator outputs are latched in their current state whilst the output data latch is made transparent and the results of the new sample appear at the data outputs.

When STROBE goes high again this new value is latched at the data outputs whilst the comparators again sample the input. In this way valid data always appears at the outputs except at a negative going STROBE edge. A STROBE timing diagram is shown in figure 2.

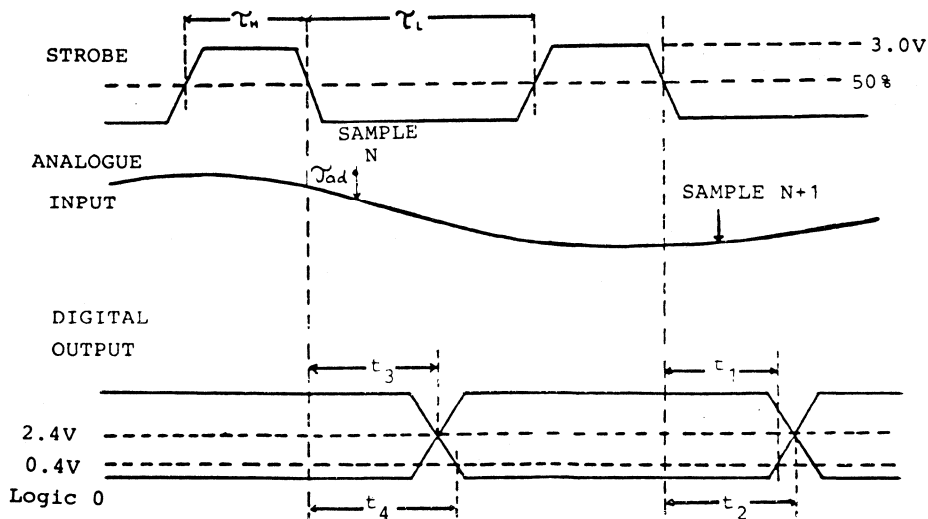

FIG. 2. STROBE TIMING

ZN440

Output ENABLE

All logic outputs of the ZN440 are of the open-collector type requiring an external pullup of nominally 2k. The data output transistors may be turned off by taking the ENABLE pin high. A timing diagram for output enable/disable delays is given in figure 3.

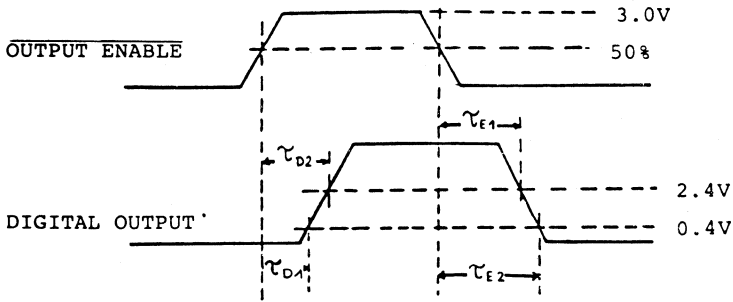

FIG. 3. OUTPUT ENABLE TIMING

Underrange/Overrange

When the analogue input voltage is less than the threshold of comparator 1 the data outputs turned off and the underrange output is low. Similarly, if the analogue input is above the threshold of comparator 64 then the outputs are also turned off.

Whenever the input voltage is greater than the threshold of comparator 1 then the underrange output is high.

Stacking

Provision of an underrange output and the fact that both ends of the reference resistor chain are accessible means that two or four ZN440's can easily be stacked to form a 7- or 8- bit converter. In theory the reference resistor chains of two or four ZN440's could simply be connected in series to give an array of 128 or 256 comparators and thus 7- or 8- bit resolution.

However, due to differences in the absolute value of resistor between different ICs the voltage drop across each reference chain might not be the same, giving rise to linearity errors.

To overcome this problem the ZN440 is provided with (untapped) resistors at each end of the reference chain. By making suitable connection to these resistors it is possible to make each ZN440 operate over half the total reference voltage in the case of the 7-bit stack or one-quarter of the total reference voltage in the case of the 8-bit stack. The reference chain connections for 7- and 8-bit stacks, for both unipolar and bipolar operation, are shown in figure 4.

The matching of the reference resistors is sufficiently accurate to ensure that linearity is maintained for the 7- and 8-bit stacks. Each converter operates over its own portion of the reference range without any overlap or gaps at the transition points.

Note that the total reference voltage for the stacked converters should be chosen so that the reference voltage across the reference chain (R4) in each converter is within the 0.5 to 1V limit, e.g. for the 8-bit unipolar stack the total reference voltage should be between 2V and 4V.

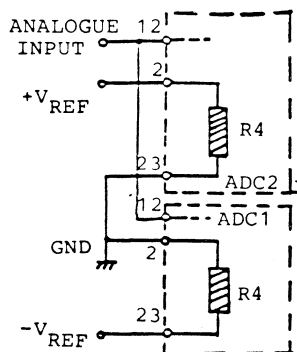

7-BIT (BIPOLAR INPUT RANGE
SYMMETRICAL ABOUT ZERO)

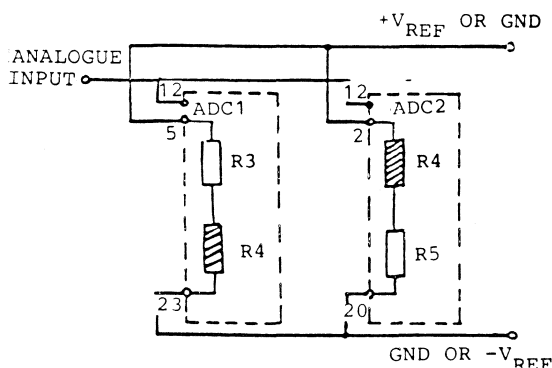

8-BIT (UNIPOLAR OR
ASYMMETRIC BIPOLAR INPUT)

7-BIT (UNIPOLAR OR
ASYMMETRIC BIPOLAR INPUT)

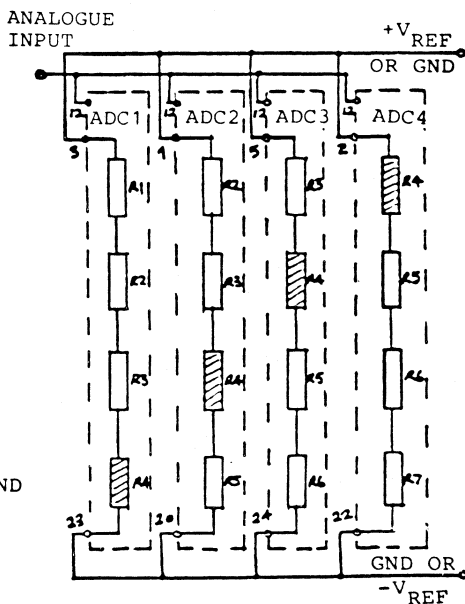

ZN440

In stacked configurations the six least significant bits are obtained simply by bussing together the D_0 to D_6 outputs of all the converters. In the case of a 7-bit stack the MSB (D_6) is simply the underrange of the second converter, as shown in figure 5. In order to give the same loading conditions as the other six outputs it is wire AND-ed to the output of the first converter though this has no effect from a logic point of view.

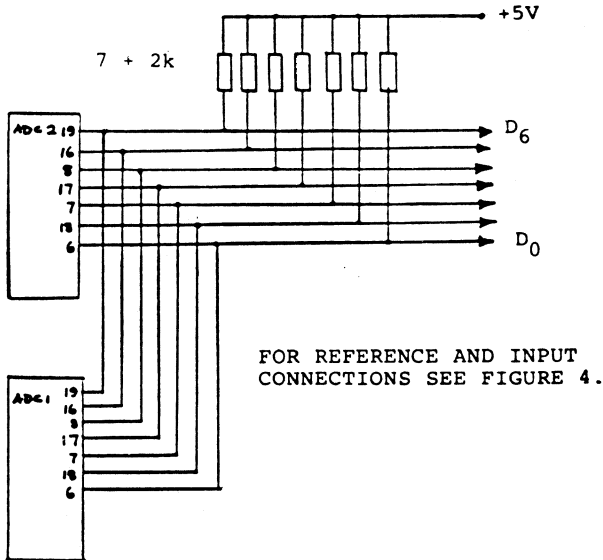
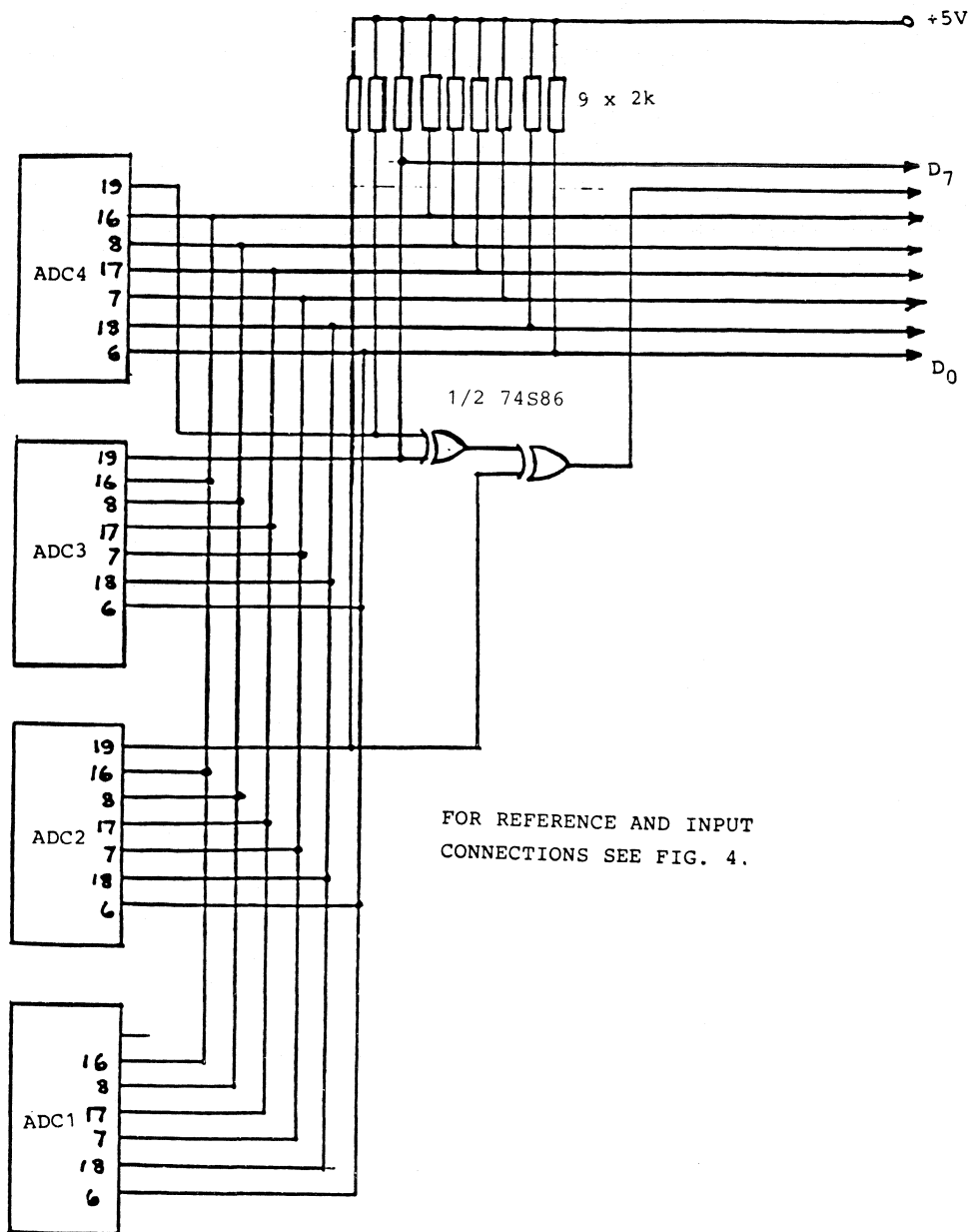

Fig. 5. LOGIC CONNECTIONS FOR 7-BIT STACKING

For the eight bit configuration bit 7 and bit 8 are obtained by decoding the underrange outputs using two exclusive-OR gates as shown in figure 6. This, of course, increases the conversion time due to the additional propagation delays introduced into the bit 7 and bit 8 outputs.



FOR REFERENCE AND INPUT
CONNECTIONS SEE FIG. 4.

**FIG. 6. LOGIC CONNECTIONS FOR
8-BIT STACKING**

ZN440

Clock Generator and Strobe Driver Circuit

A suggested circuit for generating the STROBE pulses to the ZN440 is shown in figure 7. This consists of an oscillator based on Schmitt trigger N1 driving a pulse shaper circuit comprising N3-N6. The clock frequency and STROBE high period can be independently adjusted using P1 and P2 respectively.

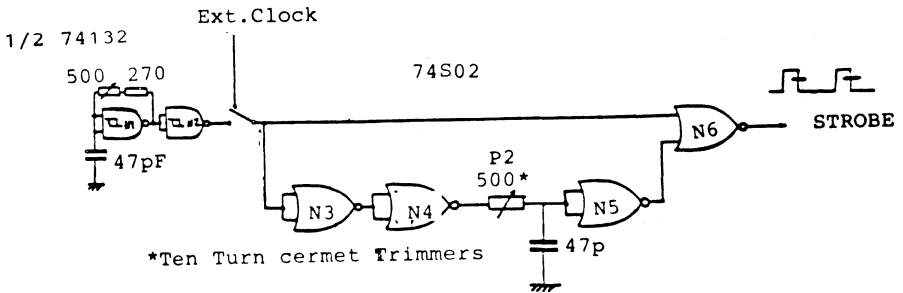

FIG. 7. CLOCK GENERATOR AND STROBE PULSE SHAPER

Test Circuit

A suggested test circuit for the ZN440 is shown in figure 8a. The loading conditions on all data outputs should be as shown in figure 8b.

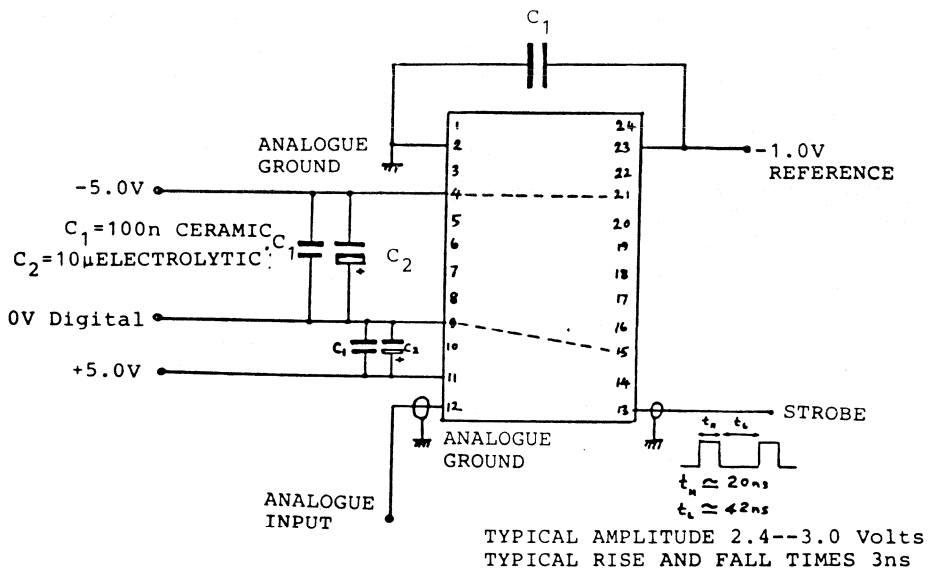

FIG. 8a. ZN440 TEST CIRCUIT

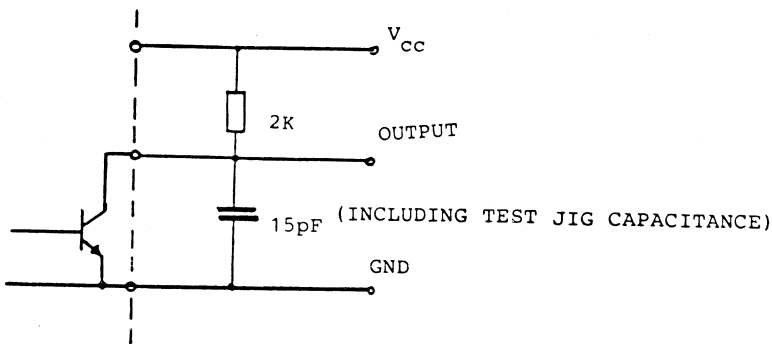
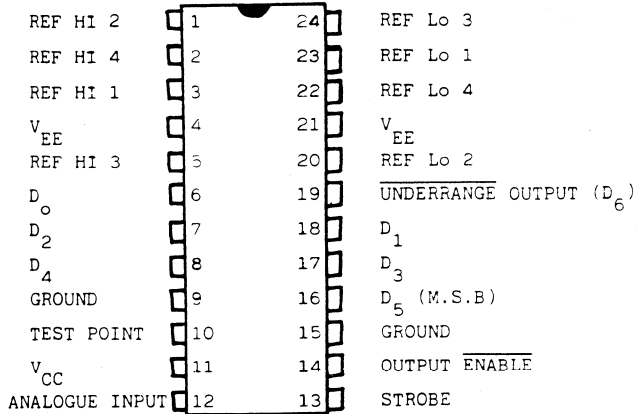

FIG. 8b. ZN440 OUTPUT TEST CIRCUIT

ZN440



ZN440 PIN CONNECTIONS

8-Bit μ P — Compatible A to D Converters
FEATURES

- Easy interfacing to microprocessors or operates as a 'stand alone' converter
- Fast 9 μ s conversion time guaranteed
- Choice of linearity: $\frac{1}{4}$ LSB—ZN447, $\frac{1}{2}$ LSB—ZN448, 1 LSB—ZN449
- On-chip clock
- Choice of on-chip or external reference voltage
- Unipolar or bipolar input ranges
- Choice of commercial or military temperature range

DESCRIPTION

The ZN447, ZN448 and ZN449 are 8-bit, successive approximation A to D converters designed for easy interfacing to microprocessors. All active circuitry is contained on-chip including a clock generator and stable 2.5V bandgap reference.

Only a reference resistor and capacitor, clock resistor and capacitor and input resistors are required for operation with either unipolar or bipolar input voltages. The ZN447, -8 and -9 are the most complete 8-bit monolithic ADCs available.

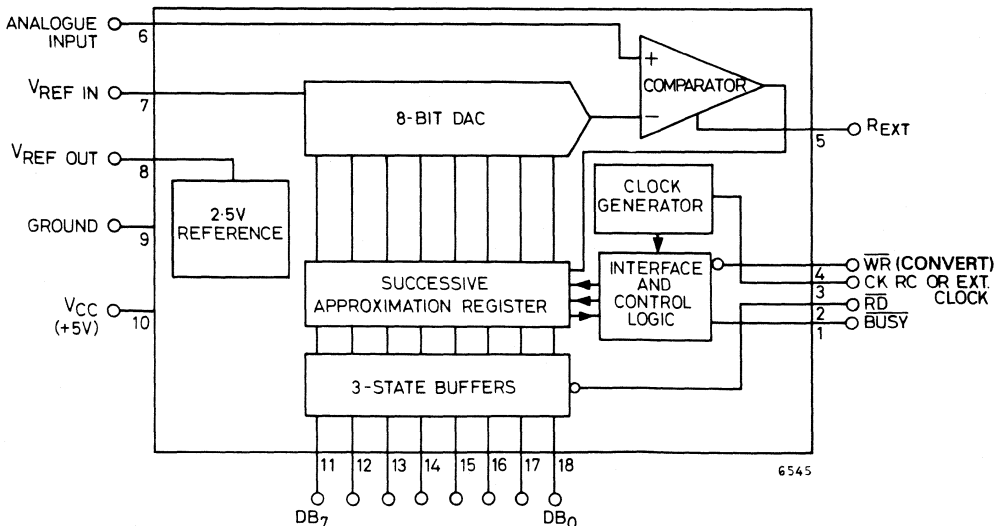
Fig. 1 SYSTEM DIAGRAM

ZN447/8/9

ABSOLUTE MAXIMUM RATINGS

Supply Voltage, V_{CC}	+ 7.0 volts
Max. Voltage, Logic and V_{REF} Inputs.....	V_{CC}
Operating Temperature Range.....	0°C to + 70°C ('E' package) - 55°C to + 125°C ('J' package)
Storage Temperature Range.....	- 55°C to + 125°C

ELECTRICAL CHARACTERISTICS ($V_{CC} = +5V$, $T_{amb} = 25^{\circ}C$, $f_{c1k} = 900kHz$, unless otherwise stated).

Parameter	Min.	Typ.	Max.	Units	Conditions
ZN447					
Linearity Error	—	—	$\pm 1/4$	LSB	
Differential Linearity Error	—	—	$\pm 1/2$	LSB	
Zero Transition (00000000 → 00000001)	13.5	15	16.5	mV	Moulded 'E' package
Full-scale Transition (11111110 → 11111111)	15.0	16.5	18.0	mV	Ceramic 'J' package
	2.548	2.550	2.552	V	$V_{REF} = 2.560V$
ZN448					
Linearity Error	—	—	$\pm 1/2$	LSB	
Differential Linearity Error	—	—	± 1	LSB	
Zero Transition (00000000 → 00000001)	12.0	15.0	18.0	mV	Moulded 'E' package
Full-scale Transition (11111110 → 11111111)	13.0	16.5	20.0	mV	Ceramic 'J' package
	2.545	2.550	2.555	V	$V_{REF} = 2.560V$
ZN449					
Linearity Error	—	—	± 1	LSB	
Differential Linearity Error	—	—	± 2	LSB	
Zero Transition (00000000 → 00000001)	10.0	15.0	20.0	mV	Moulded 'E' package
Full-scale Transition (11111110 → 11111111)	11.5	16.5	21.5	mV	Ceramic 'J' package
	2.542	2.550	2.558	V	$V_{REF} = 2.560V$
ALL TYPES					
Resolution	8	—	—	Bits	
Linearity Temperature Coefficient	—	± 3.0	—	ppm/°C	
Differential Linearity Temperature Coefficient	—	± 6.0	—	ppm/°C	
Full-scale Temperature Coefficient	—	± 2.5	—	ppm/°C	
Zero Temperature Coefficient	—	± 8.0	—	$\mu V/^{\circ}C$	
Reference Input Range	1	—	3	V	
Supply Voltage	4.5	5	5.5	V	
Supply Current	—	25	40	mA	
Power Consumption	—	125	—	mW	

ELECTRICAL CHARACTERISTICS ($V_{CC} = +5V$, $T_{amb} = 25^{\circ}C$, $f_{c1k} = 900kHz$, unless otherwise stated).					
Parameter	Min.	Typ.	Max.	Units	Conditions
COMPARATOR					
Input Current	—	1	—	μA	$V_{IN} = +3V$, $R_{EXT} = 82k$
Input Resistance	—	100	—		
Tail Current	25	65	150	μA	$V- = -5v$
Negative Supply	-3	-5	-30	V	
Input Voltage	-0.5	—	+3.5	V	
ON CHIP REFERENCE					
Output Voltage ZN447	2.530	2.550	2.570		$R_{REF} = 390 \Omega$
ZN448	2.520	2.550	2.580	V	
ZN449	2.500	2.550	2.600		$C_{REF} = 4\mu 7$
Slope Resistance	—	0.5	2	ohms	
V_{REF} Temperature Coefficient	—	50	—	ppm/ $^{\circ}C$	
Reference Current	4	—	15	mA	
CLOCK					
On-chip Clock Frequency	—	—	1	MHz	
Clock Frequency Tempco	—	+0.5	—	%/ $^{\circ}C$	
Clock Resistor	—	—	2.0	kohms	
Maximum External Clock Frequency	—	0.9	1	MHz	
Clock Pulse Width	500	—	—	ns	
High Level Input Voltage V_{IH}	4.0	—	—	V	
Low Level Input Voltage V_{IL}	—	—	0.8	V	
High Level Input Current I_{IH}	—	—	800	μA	$V_{IN} = +4.0V$, $V_{CC} = MAX$
Low Level Input Current I_{IL}	—	—	-500	μA	$V_{IN} = +0.8V$, $V_{CC} = MAX$
LOGIC (over operating temperature range)					
CONVERT INPUT					
High Level Input Voltage V_{IH}	2	—	—	V	
Low Level Input Voltage V_{IL}	—	—	0.8	V	
High Level Input Current I_{IH}	—	300	—	μA	$V_{IN} = +2.4V$, $V_{CC} = MAX$
Low Level Input Current I_{IL}	—	± 10	—	μA	$V_{IN} = +0.4V$, $V_{CC} = MAX$
RD INPUT					
High Level Input Voltage V_{IH}	2.0	—	—	V	
Low Level Input Voltage V_{IL}	—	—	0.8	V	
High Level Input Current I_{IH}	—	-150	—	μA	$V_{IN} = +2.4V$, $V_{CC} = MAX$
Low Level Input Current I_{IL}	—	-300	—	μA	$V_{IN} = +0.4V$, $V_{CC} = MAX$

ZN447/8/9

ELECTRICAL CHARACTERISTICS ($V_{CC} = +5V$, $T_{amb} = 25^{\circ}C$, $f_{clk} = 900kHz$, unless otherwise stated).					
Parameter	Min.	Typ.	Max.	Units	Conditions
High Level Output Voltage V_{OH}	2.4	—	—	V	$I_{OH} = MAX, V_{CC} = MIN$ $I_{OL} = MAX, V_{CC} = MIN$
Low Level Output Voltage V_{OL}	—	—	0.4	V	
High Level Output Current I_{OH}	—	—	- 100	μA	$V_{OUT} = +2.0V$
Low Level Output Current I_{OL}	—	—	1.6	mA	
Three-state Disabled Output Leakage	—	—	2	μA	
Input Clamp Diode Voltage	—	—	- 1.5	V	
\overline{RD} Input to Data Output Enable/Disable	—	180	250	ns	
Delay Times T_{E1}	180	210	260	ns	
T_{E0}	60	80	100	ns	
T_{D1}	80	110	140	ns	
T_{D0}	60	80	100	ns	
Convert Pulse Width $T_{\overline{WR}}$	200	—	—	ns	
\overline{WR} Input to \overline{BUSY} Output	—	—	250	ns	
Propagation Delay T_{BD}	—	—	—	—	

GENERAL CIRCUIT OPERATION

The ZN447 utilises the successive approximation technique. Upon receipt of a negative-going pulse at the \overline{WR} input the \overline{BUSY} output goes low, the MSB is set to 1 and all other bits are set to 0, which produces an output voltage of $V_{REF/2}$ from the DAC. This is compared to the input voltage V_{IN} ; a decision is made on the next negative clock edge to reset the MSB to 0 if $\frac{V_{REF}}{2} V_{IN}$ or leave it set to 1 if $\frac{V_{REF}}{2} V_{IN}$. Bit 2 is set to 1 on the same clock edge, producing an output from the DAC of $\frac{V_{REF}}{4}$ or $\frac{V_{REF}}{2} + \frac{V_{REF}}{4}$ depending on the state of the MSB. This voltage is compared to V_{IN} and on the next clock edge a decision is made regarding bit 2, whilst bit 3 is set to 1. This procedure is repeated for all eight bits. On the eighth negative clock edge \overline{BUSY} goes high indicating that the conversion is complete.

During a conversion the \overline{RD} input will normally be held high to keep the 3-state buffers in their high impedance state. Data can be read out by taking \overline{RD} low, thus enabling the 3-state outputs. Readout is non-destructive.

CONVERSION TIMING

The ZN447 will accept a low-going CONVERT pulse, which can be completely asynchronous with respect to the clock, and will produce valid data between $7\frac{1}{2}$ and $8\frac{1}{2}$ clock pulses later depending on the relative timing of the clock and CONVERT signals. Timing diagrams for a conversion are shown in figure 2.

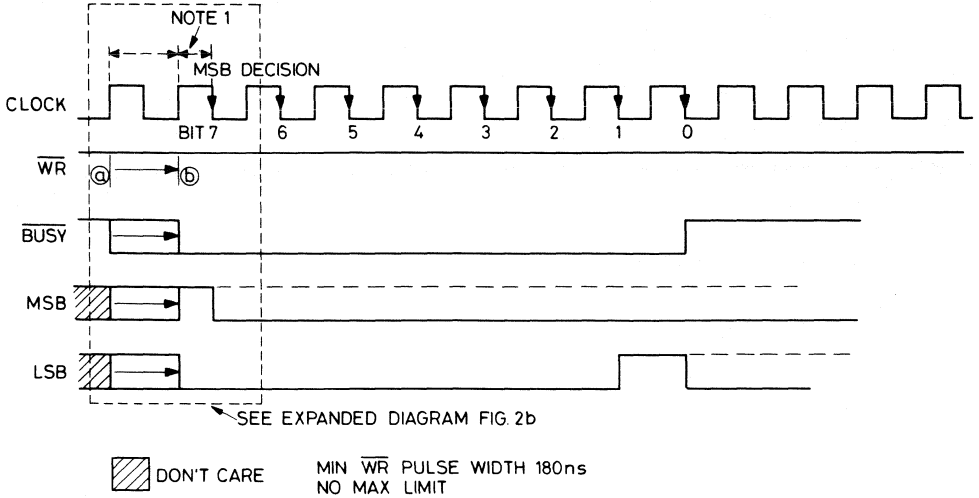

NOTE 1. GUARANTEED PERIOD OF $\frac{1}{2}$ CLOCK CYCLE MIN. $1\frac{1}{2}$ CLOCK CYCLES MAX. ALLOWS MSB TO SETTLE BEFORE MSB DECISION

FIG 2a

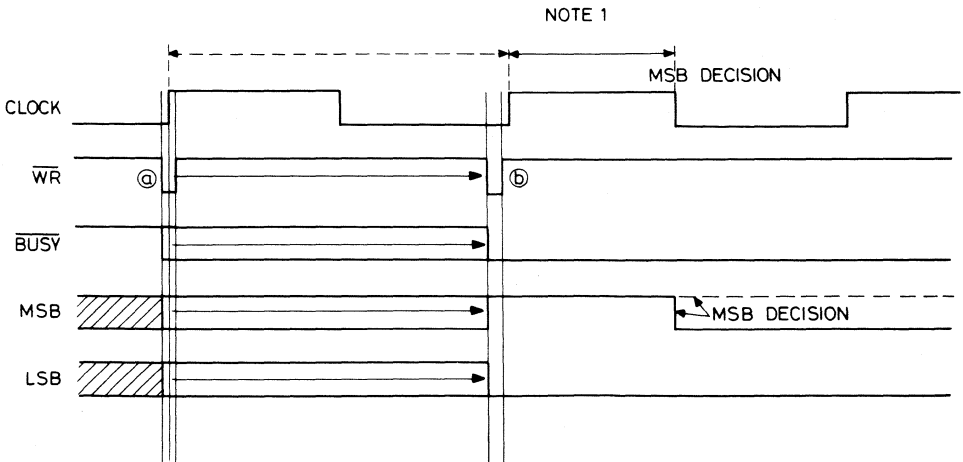

FIG 2b (EXPANDED INSET)

6554

Fig. 2 ZN447 TIMING DIAGRAMS

ZN447/8/9

The converter is cleared by a low-going CONVERT pulse, which sets the most significant bit and resets all the other bits and the $\overline{\text{BUSY}}$ flag. Whilst the CONVERT input is low the MSB output of the DAC is continuously compared with the analogue input, but otherwise the converter is inhibited.

After the CONVERT input goes high again the MSB decision is made and the successive approximation routine runs to completion.

The CONVERT pulse can be as short as 200ns; however the MSB must be allowed to settle for at least 550ns before the MSB decision is made. To ensure that this criterion is met even with short CONVERT pulses the converter waits, after the CONVERT input goes high, for a rising clock edge followed by a falling clock edge, the MSB decision being taken on the falling clock edge. This ensures that the MSB is allowed to settle for at least half a clock period, or 550ns at maximum clock frequency. The CONVERT input is not locked out during a conversion and if it is pulsed low at any time the conversion will restart.

The $\overline{\text{BUSY}}$ output goes high at the end of a conversion indicating data valid. Note that if the three-state data outputs are enabled during a conversion then valid data will be available at the outputs on the rising edge of the $\overline{\text{BUSY}}$ signal. If, however the outputs are not enabled until after $\overline{\text{BUSY}}$ goes high then the data will be subject to the propagation delay of the three-state buffers. (See under DATA OUTPUTS).

CONTINUOUS CONVERSION

If a free-running conversion is required then the converter can be made to cycle by inverting the $\overline{\text{BUSY}}$ output and feeding it to the CONVERT input. To ensure that the converter starts reliably after power up an initial start pulse is required. This can be ensured by using a NOR gate instead of an inverter and feeding it with a positive going pulse which can be derived from a simple RC network that gives a single pulse when power is applied, as shown in figure 3a.

The ADC will complete a conversion on every eighth clock pulse, with the $\overline{\text{BUSY}}$ output going high for a period determined by the propagation delay of the NOR gate, during which time the data can be stored in a latch. The time available for storing the data can be increased by inserting delays into the inverter path.

A timing diagram for the continuous conversion mode is shown in figure 3b.

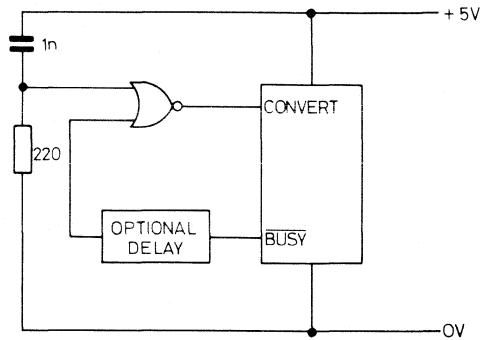

6546

Fig. 3a CIRCUIT FOR CONTINUOUS CONVERSION

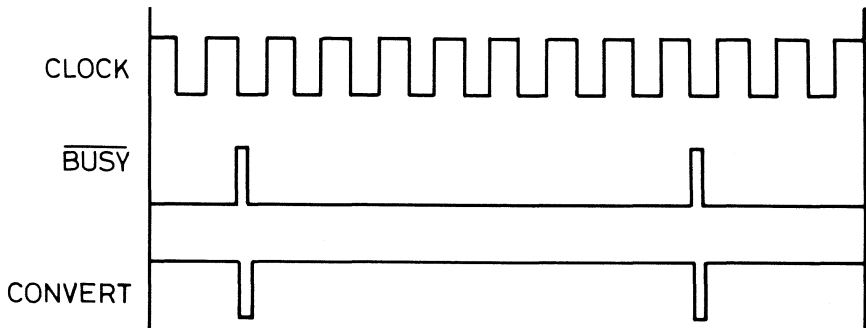

6547

Fig. 3b TIMING FOR CONTINUOUS CONVERSION

As the $\overline{\text{BUSY}}$ output uses a passive pullup the rise time of this output depends on the RC time constant of the pullup resistor and load capacitance. In the continuous conversion mode the use of a 4k7 external pullup resistor is recommended to reduce the risetime and ensure that a logic 1 level is reached.

DATA OUTPUTS

The data outputs are provided with 3-state buffers to allow connection to a common data bus. An equivalent circuit is shown in figure 4. Whilst the $\overline{\text{RD}}$ input is high both output transistors are turned off and the ZN447 presents only a high impedance load to the bus. When $\overline{\text{RD}}$ is low the data outputs will assume the logic states present at the outputs of the successive approximation register.

A test circuit and timing diagram for the output enable/disable delays are given in figure 5.

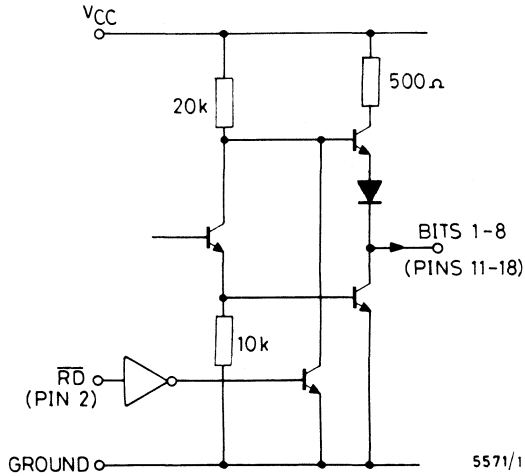

Fig. 4 DATA OUTPUT

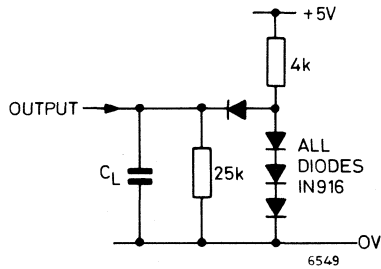
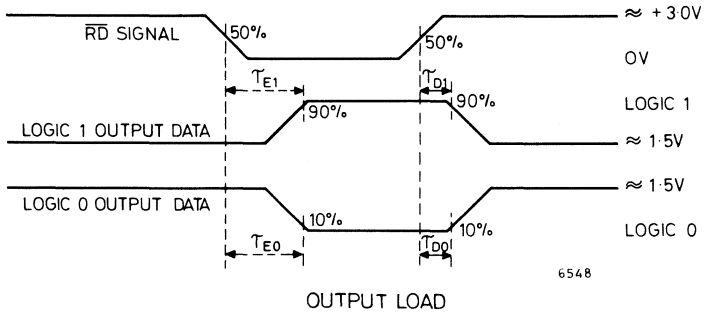

Fig. 5 OUTPUT ENABLE/DISABLE DELAYS

BUSY OUTPUT

The $\overline{\text{BUSY}}$ output, shown in figure 6, utilises a passive pullup for CMOS/TTL compatibility. This also allows up to four $\overline{\text{BUSY}}$ outputs to be wire-ANDed together to form a common interrupt line.

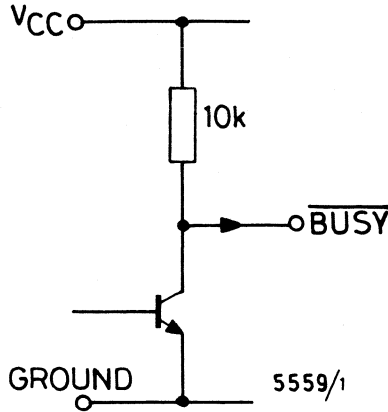
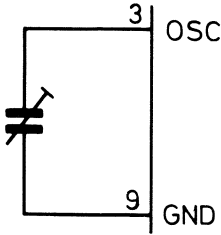

Fig. 6 $\overline{\text{BUSY}}$ OUTPUT

ON-CHIP CLOCK

The on-chip clock operates with only a single external capacitor connected between pin 3 and ground as shown in figure 7a. A graph of typical oscillator frequency versus capacitance is given in figure 8. The oscillator frequency may be trimmed by means of an external resistor in series with the capacitor, as shown in figure 7b. For optimum accuracy and stability of the oscillator frequency without trimming the use of a crystal or ceramic resonator is recommended, as shown in figure 7c. The final option is to overdrive the oscillator input with an external clock signal from a TTL or CMOS gate, as shown in figure 7d.

ZN447/8/9



a) FIXED/VARIABLE CAPACITOR

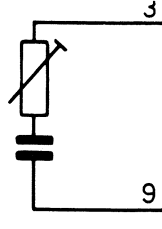

b) FIXED CAPACITOR + VARIABLE RESISTOR

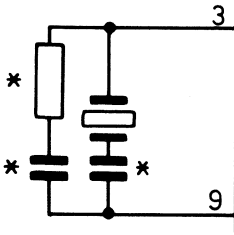

* LOAD CIRCUIT TO SUIT DEVICE USED

c) CRYSTAL OR RESONATOR

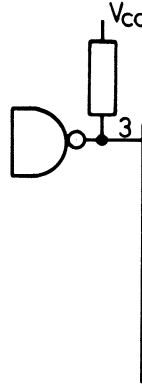

d) EXTERNAL TTL OR CMOS DRIVE

6550

Fig. 7 CLOCK CIRCUIT EXTERNAL COMPONENTS

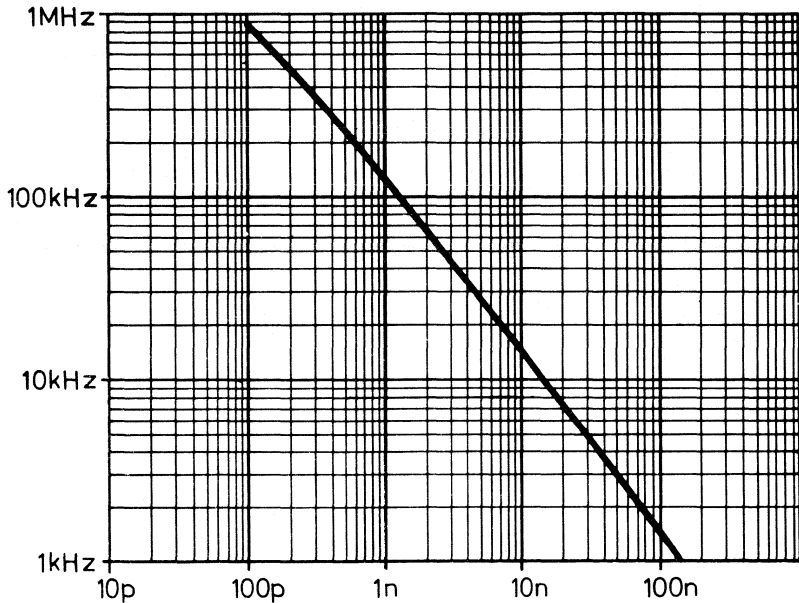

6551

Fig. 8 TYPICAL CLOCK FREQUENCY vs. C_{CR} (R_{CK} = 0)

**ANALOGUE CIRCUITS
D to A CONVERTER**

The converter is of the voltage switching type and uses an R-2R ladder network as shown in figure 9. Each element is connected to either 0V or V_{REF IN} by transistor voltage switches specially designed for low offset voltage (1 millivolt).

A binary weighted voltage is produced at the output of the R-2R ladder:

$$D \text{ to A output} = \frac{n}{256} (V_{REF IN} - V_{OS}) + V_{OS}$$

where n is the digital input to the D to A from the successive approximation register.

V_{OS} is a small offset voltage that is produced by the device supply current flowing in the package lead resistance. This offset will normally be removed by the setting up procedure and since the offset temperature coefficient is low (8 μV/°C) the effect on accuracy will be negligible.

The D to A output range can be considered to be 0 - V_{REF IN} through an output resistance R (4k).

ZN447/8/9

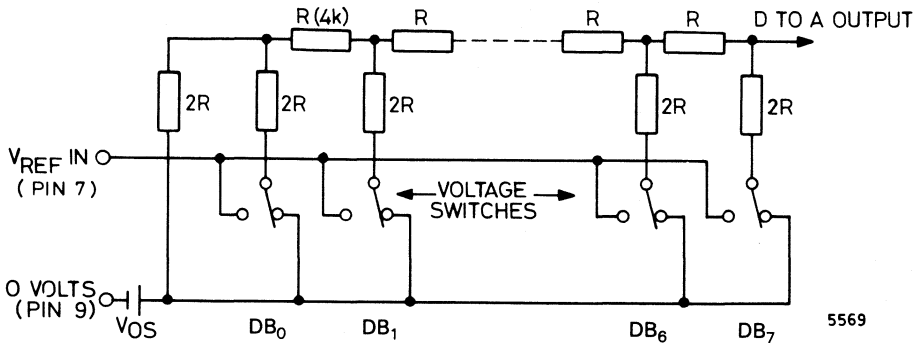

5569

Fig. 9 R2-R LADDER NETWORK

REFERENCE

(a) Internal Reference

The internal reference is an active band gap circuit which is equivalent to a 2.5V Zener diode with a very low slope impedance (figure 10). A resistor (R_{REF}) should be connected between pins 8 and 10.

The recommended value of 390Ω will supply a nominal reference current of $(5.0 - 2.5) / 0.39 = 6.4\text{mA}$. A stabilising/decoupling capacitor, C_{REF} ($4\mu\text{F}$), is required between pins 8 and 9. For internal reference operation $V_{REF OUT}$ (Pin 8) is connected to $V_{REF IN}$ (Pin 7).

Up to five ZN447s may be driven from one internal reference, there being no need to reduce R_{REF} . This useful feature saves power and gives excellent gain tracking between the converters.

Alternatively the internal reference can be used as the reference voltage for other external circuits and can source or sink up to 3mA.

(b) External Reference

If required an external reference voltage in the range +1.5 to +3.0 volts may be connected to $V_{REF IN}$. The slope resistance of such a reference source should be less than $\frac{2.5\Omega}{n}$, where n is the number of converters supplied.

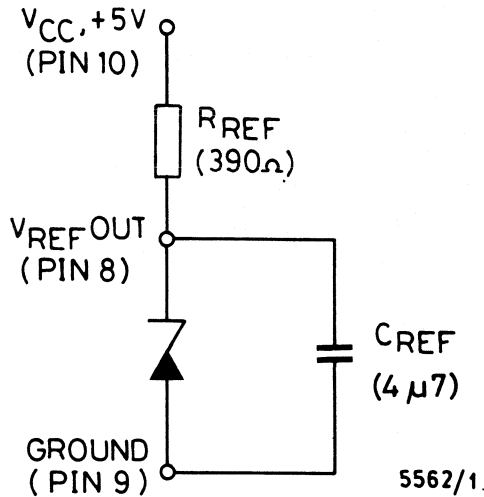

Fig. 10 INTERNAL VOLTAGE REFERENCE

RATIOMETRIC OPERATION

If the output from a transducer varies with its supply then an external reference for the ZN447 should be derived from the same supply. The external reference can vary from +1.5 volts to +3.0 volts. The ZN447 will operate if $V_{REF IN}$ is less than +1.5 volts but reduced overdrive to the comparator will increase its delay and so the conversion time will need to be increased.

COMPARATOR

The ZN447 contains a fast comparator, the equivalent input circuit of which is shown in figure 11. A negative supply voltage is required to supply the tail current of the comparator. However as this is only 25 to 150 μA and need not be well stabilised it can be supplied by a simple diode pump circuit driven from the \overline{BUSY} output.

ZN447/8/9

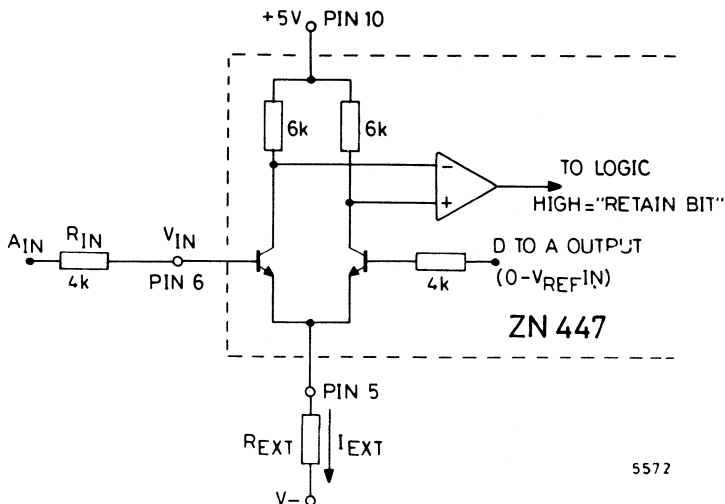

Fig. 11 COMPARATOR EQUIVALENT CIRCUIT

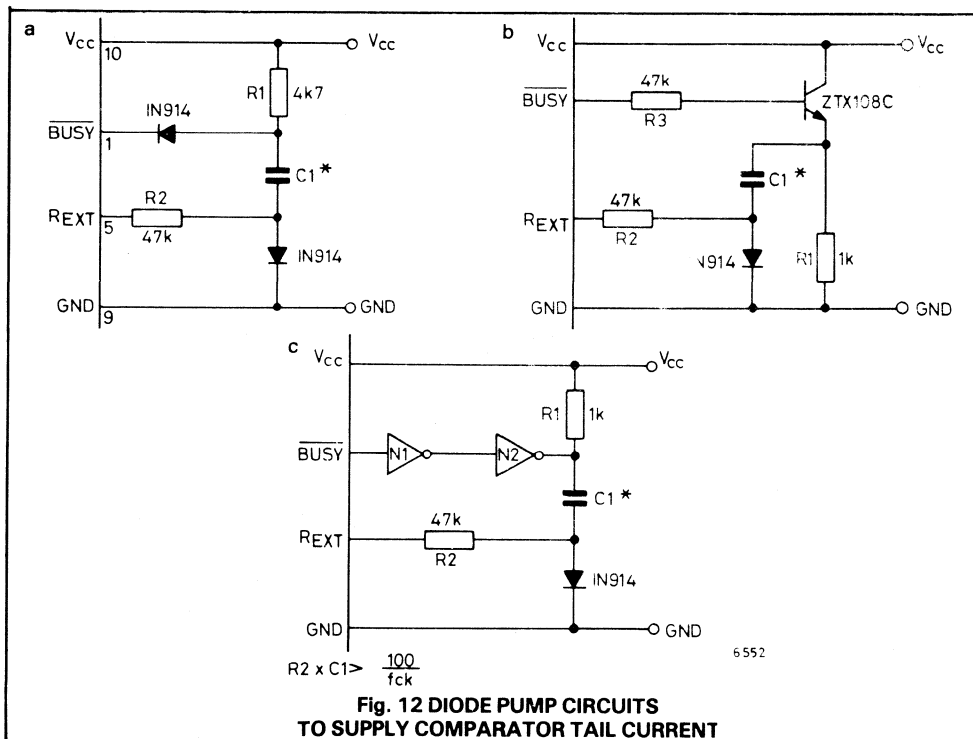
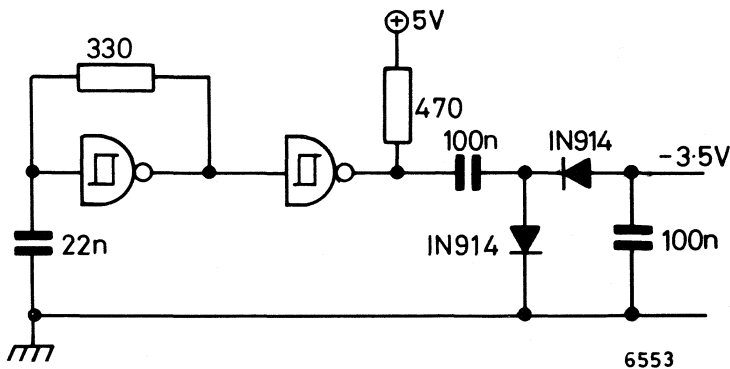

Fig. 12 DIODE PUMP CIRCUITS TO SUPPLY COMPARATOR TAIL CURRENT

Several suitable circuits are shown in figure 12. The principle of operation is the same in each case. Whilst the $\overline{\text{BUSY}}$ output is high capacitor C1 is charged to about 4. - 4.5 volts. During a conversion the $\overline{\text{BUSY}}$ output goes low and the upper end of C1 is thus also pulled low. The lower end of C1 therefore applies about -4V to R2, thus providing the tail current for the comparator. The time constant R2.C1 is chosen according to the clock frequency so that droop of the capacitor voltage is not significant during a conversion.

The constraint on using this type of circuit is that C1 must be recharged whilst the $\overline{\text{BUSY}}$ output is high. If the $\overline{\text{BUSY}}$ output is high for greater than one converter clock period then the circuit of figure 12a will suffice. If this is not the case, for example, in the continuous conversion mode, then the circuits of figures 12b and 12c are recommended, since these can pump more current into the capacitor.

Where several ZN447s are used in a system the self-oscillating diode pump circuit of figure 13 is recommended. Alternatively, if a negative supply is available in the system then this may be utilised. A list of suitable resistor values for different supply voltages is given in table 1.



**Fig. 13 DIODE PUMP CIRCUIT TO SUPPLY COMPARATOR
TAIL CURRENT FOR UP TO FIVE ZN447's.**

ZN447/8/9

V- (Volts)	R _{EXT} (k Ω)
3	47
5	82
10	150
12	180
15	220
20	330
25	390
30	470

ANALOGUE INPUT RANGES

The basic connection of the ZN447 shown in figure 14 has an analogue input range 0 to $V_{REF IN}$

which, in some applications, may be made available from previous signal conditioning /scaling circuits. Input voltage ranges greater than this are accommodated by providing an attenuator on the comparator input, whilst for smaller input ranges the signal must be amplified to a suitable level.

Bipolar input ranges are accommodated by offsetting the analogue input range so that the comparator always sees a positive input voltage.

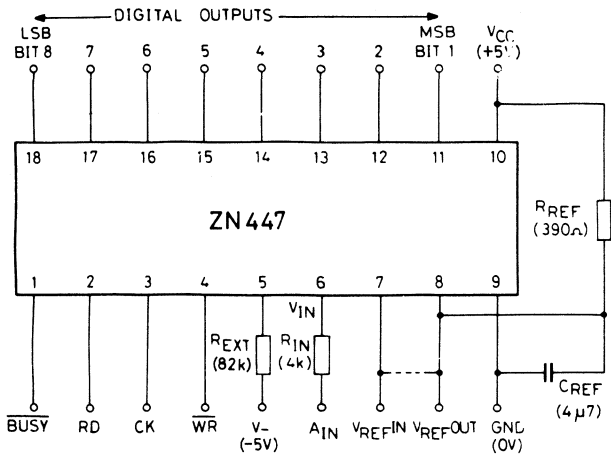

NOMINAL A_{IN} RANGE = 0 TO $V_{REF IN}$

5567/z

Fig. 14 EXTERNAL COMPONENTS FOR BASIC OPERATION

UNIPOLAR OPERATION

The general connection for unipolar operation is shown in figure 15.

The values of R_1 and R_2 are chosen so that $V_{IN} = V_{REF IN}$ when the Analogue Input (A_{IN}) is at full scale.

The resulting full scale range is given by: $A_{IN FS} = (1 + \frac{R_1}{R_2}) \cdot V_{REF IN} = G \cdot V_{REF IN}$.

To match the ladder resistance R_1/R_2 (R_{IN}) = 4k.

The required nominal values of R_1 and R_2 are given by $R_1 = 4G \text{ k}$, $R_2 = \frac{4G}{G-1} \text{ k}$.

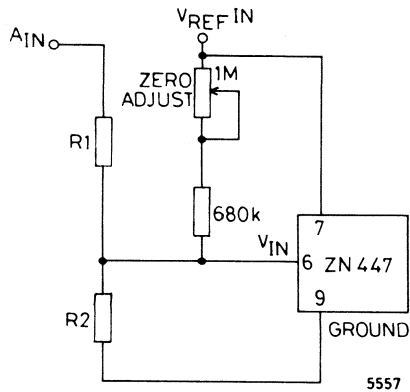

Fig. 15 GENERAL UNIPOLAR INPUT CONNECTIONS

Using these relationships a table of nominal values of R_1 and R_2 can be constructed for $V_{REF IN} = 2.5$ volts.

INPUT RANGE	G	R_1	R_2
+ 5V	2	8k	8k
+ 10V	4	16k	5.33k

ZN447/8/9

GAIN ADJUSTMENT

Due to tolerances in R_1 and R_2 , tolerances in V_{REF} and the gain (full-scale) error of the DAC, some adjustment should be incorporated into R_1 to calibrate the full-scale of the converter. When used with the internal reference and 2% resistors a preset capable of adjusting R_1 by at least $\pm 5\%$ of its nominal value is suggested.

ZERO ADJUSTMENTS

Due to offsets in the DAC and comparator the zero (0 to 1) code transition would occur with typically 15mV applied to the comparator input, which corresponds to $1\frac{1}{2}$ LSB with a 2.56 volt reference.

Zero adjustment must therefore be provided to set the zero transition to its correct value of $+\frac{1}{2}$ LSB or 5mV with a 2.56V reference. This is achieved by applying an adjustable positive offset to the comparator input via P2 and R3. The values shown are suitable for all input ranges greater than $1\frac{1}{2}$ times $V_{REF IN}$.

Practical circuit values for +5V and +10V input ranges are given in figure 16 which incorporates both zero and gain adjustments.

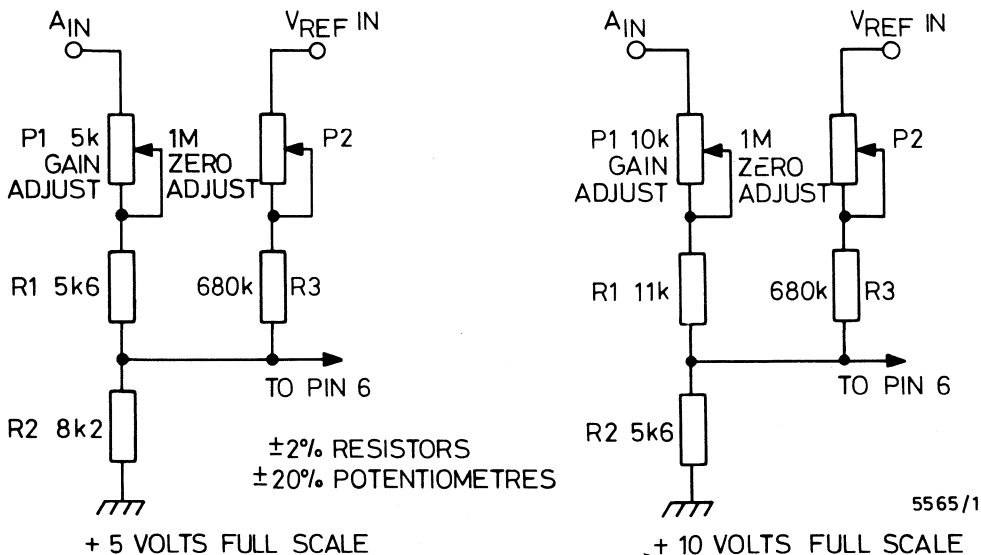

Fig. 16 UNIPOLAR OPERATION COMPONENT VALUES

UNIPOLAR ADJUSTMENT PROCEDURE

- (i) Apply continuous convert pulses at intervals long enough to allow a complete conversion and monitor the digital outputs.
- (ii) Apply full scale minus $1\frac{1}{2}$ LSB to A_{IN} and adjust gain until Bit 8 (LSB) output just flickers between 0 and 1 with all other bits at 1.
- (iii) Apply $\frac{1}{2}$ LSB to A_{IN} and adjust zero until Bit 8 just flickers between 0 and 1 with all other bits at 0.

UNIPOLAR SETTING – UP POINTS

INPUT RANGE, +FS	$\frac{1}{2}$ LSB	FS – $1\frac{1}{2}$ LSB
+5V +10V	9.8mV 19.5mV	4.9797 volts 9.9414 volts

$$1 \text{ LSB} = \frac{FS}{256}$$

UNIPOLAR LOGIC CODING

ANALOGUE INPUT (A_{IN}) (NOMINAL CODE CENTRE VALUE)	OUTPUT CODE (BINARY)
FS – 1 LSB	11111111
FS – 2 LSB	11111110
$\frac{3}{4}$ FS	11000000
$\frac{1}{2}$ FS + 1 LSB	10000001
$\frac{1}{2}$ FS	10000000
$\frac{1}{2}$ FS – 1 LSB	01111111
$\frac{1}{4}$ FS	01000000
1 LSB	00000001
0	00000000

BIPOLAR OPERATION

For bipolar operation the input to the ZN447 is offset by half full scale by connecting a resistor R_3 between $V_{REF\ IN}$ and V_{IN} (figure 17).

ZN447/8/9

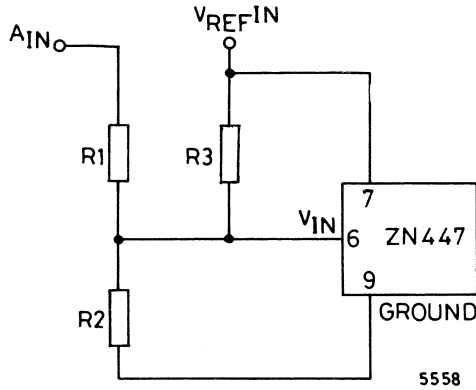

Fig. 17 BASIC BIPOLAR INPUT CONNECTION

When $A_{IN} = -FS$, V_{IN} needs to be equal to zero.

When $A_{IN} = +FS$, V_{IN} needs to be equal to $V_{REF IN}$.

If the full scale range is $\pm G \cdot V_{REF IN}$ then $R_1 = (G-1) \cdot R_3$ and $R_2 = G \cdot R_3$ fulfil the required conditions.

To match the ladder resistance $R_1/R_2/R_3 (= R_{IN}) = 4k$.

Thus the nominal values of R_1, R_2, R_3 are given by $R_1 = 8Gk, R_2 = 8G/(G-1)k, R_3 = 8k$.

A bipolar range of $\pm V_{REF IN}$ (which corresponds to the basic unipolar range 0 to $V_{REF IN}$) results if $R_1 = R_3 = 8k$ and $R_2 = \infty$.

Assuming the $V_{REF IN} = 2.5$ volts the nominal values of resistors for $\pm 5V$ and $\pm 10V$ input ranges are given in the following table.

INPUT RANGE	G	R_1	R_2	R_3
$\pm 5V$	2	16k	16k	8k
$\pm 10V$	4	32k	10.66k	8k

Minus full scale (offset) is set by adjusting R_1 about its nominal value relative to R_3 . Plus full scale (gain) is set by adjusting R_2 relative to R_1 .

Practical circuit realisations are given in figure 18.

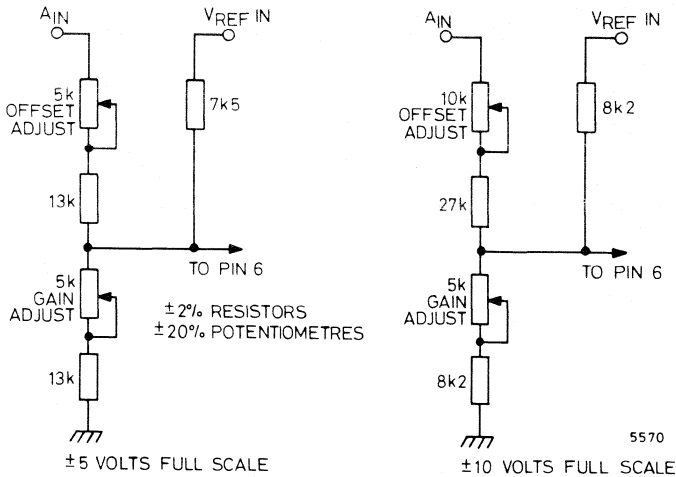

Fig. 18 BIPOLAR OPERATION—COMPONENT VALUES

Note that in the $\pm 5V$ case R_3 has been chosen as 7.5 k (instead of 8.2 k) to obtain a more symmetrical range of adjustment using standard potentiometers.

BIPOLAR ADJUSTMENT PROCEDURE

- (i) Apply continuous SC pulses at intervals long enough to allow a complete conversion and monitor the digital outputs.
- (ii) Apply $-(FS - \frac{1}{2} \text{ LSB})$ to A_{IN} and adjust offset until the Bit 8 (LSB) output just flickers between 0 and 1 with all other bits at 0.
- (iii) Apply $+(FS - 1\frac{1}{2} \text{ LSB})$ to A_{IN} and adjust gain until Bit 8 just flickers between 0 and 1 with all other bits at 1.
- (iv) Repeat step (ii).

BIPOLAR SETTING—UP POINTS

INPUT RANGE, $\pm FS$	$-(FS - \frac{1}{2} \text{ LSB})$	$+(FS - 1\frac{1}{2} \text{ LSB})$
$\pm 5V$	-4.9805V	+4.9414V
$\pm 10V$	-9.9609V	+9.8828V

$$1 \text{ LSB} = \frac{2FS}{256}$$

ZN447/8/9

BIPOLAR LOGIC CODING

ANALOGUE INPUT (A_{IN}) (NOMINAL CODE CENTRE VALUE)	OUTPUT CODE (OFFSET BINARY)
+ (FS - 1 LSB)	11111111
+ (FS - 2 LSB)	11111110
+ ½ FS	11000000
+ 1 LSB	10000001
0	10000000
- 1 LSB	01111111
- ½ FS	01000000
-(FS - 1 LSB)	00000001
-FS	00000000

ORDERING INFORMATION

TYPE	LINEARITY (LSB)	OPERATING TEMPERATURE RANGE	PACKAGE
ZN447E	¼	0°C to +70°C	Moulded
ZN447J	¼	-55°C to +125°C	Ceramic
ZN448E	½	0°C to +70°C	Moulded
ZN448J	½	-55°C to +125°C	Ceramic
ZN449E	1	0°C to +70°C	Moulded
ZN449J	1	-55°C to +125°C	Ceramic

PIN CONNECTIONS

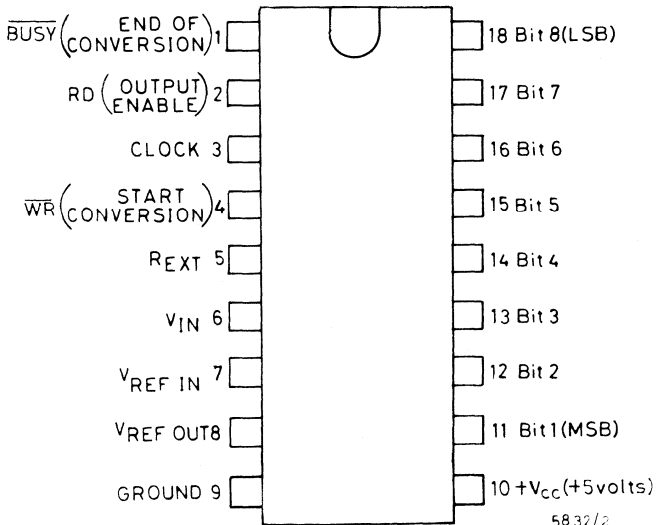

5832/2



Single Chip 3 1/2 Digit DVM IC

FEATURES

- 199.9 mV full-scale reading
- Digital Auto-zero with guaranteed zero reading for 0V input
- True polarity at zero for null detection
- True differential inputs
- Direct drive of Liquid Crystal Display
- On-chip clock and precision reference
- Underrange/overrange indication
- Low power consumption, less than 35 mW
- Wide supply voltage range, single supply rail
- No external active circuits required

DESCRIPTION

The ZN450 is a complete digital voltmeter fabricated on a monolithic chip and requires only ten external, passive components for operation. A novel charge-balancing conversion technique ensures good linearity. The auto-zero function is completely digital in operation, thus obviating the need for a capacitor to store the error voltage. This versatile I.C. can be used as the basis not only for digital voltmeters and multimeters but also for other instruments such as digital thermometers.

ABSOLUTE MAXIMUM RATINGS

Supply Voltage V_{CC}	-0.5 to +7 volts
Maximum Voltage, all other inputs	-0.5 to ($V_{CC} + 0.5$) volts
Operating Temperature range	0 to +70°C
Storage Temperature Range	-55°C to +125°C

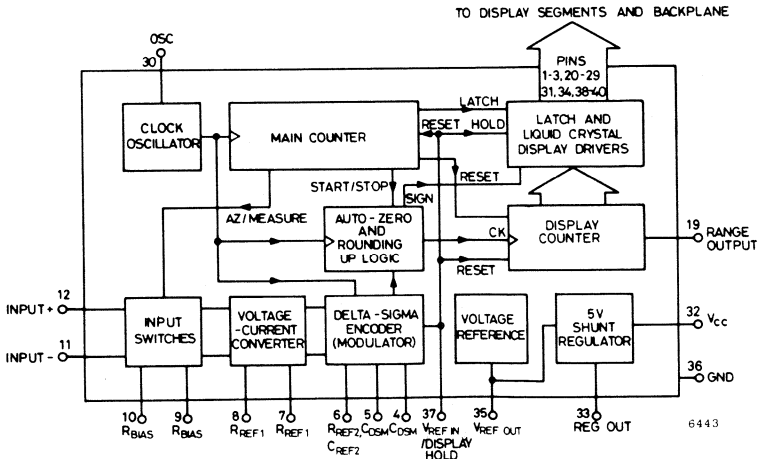

Fig. 1 - ZN450 SYSTEM DIAGRAM

ZN450E/CJ

Parameter	Min.	Typ.	Max.	Units	Conditions
Full-scale Reading	-1999	—	+1999		
Zero Reading	-000.0	±000.0	+000.0	Digital Reading	$V_{IN} = 0$, $V_{FS} = 200$ mV
Rollover Error	-2	0	+2	Count	$-V_{IN} = +V_{IN} = \pm 200$ mV conversion time ≥ 0.5 sec.
Linearity	-1	0	+1	Count	$V_{FS} = 200$ mV conversion time ≥ 0.5 sec.
Common Mode Range	1.8	—	3.8	Volts	
Common Mode Rejection	—	120	—	$\mu V/V$	
Supply Rejection	—	100	—	$\mu V/V$	
Input Offset Current	—	0.1	1	nA	Input bias resistors matched to 0.1%
Input Resistance	7	10	13	M Ω	With 10 M input resistors
Zero Temperature Coefficient	—	—	1	$\mu V/^{\circ}C$	
Full-scale Temperature Coefficient	Determined by tracking of external resistors				Ref T.C. = 0 ppm/ $^{\circ}C$
Oscillator Frequency Range	—	—	300	kHz	
Conversion Time (48000 Oscillator Periods)	0.25	—	—	Seconds	
VOLTAGE REFERENCE Output Voltage	1.26	1.3	1.35	Volts	
Temperature Coefficient	—	50	80	ppm/ $^{\circ}C$	
Knee Current	—	—	150	μA	
Maximum Sink Current	1	2	—	mA	
SUPPLY VOLTAGE (a) Direct (b) Using on-chip Shunt Regulator (c) Using external NPN transistor (d) Using two transistor regulator	4.5 6.0 6.5 5.5	5 — — —	5.5 — — —	Volts Volts Volts Volts	
Supply Current	—	4	6.5	mA	
SHUNT REGULATOR Output Voltage Sink Current	4.5 —	5 —	5.5 15	Volts mA	
DISPLAY OUTPUTS Peak Voltage	—	$\pm V_{CC}$	—		
D.C. Component	—	—	± 25	mV	
Backplane Frequency	—	$\frac{1}{2000}$	—	Oscillator Frequency	

GENERAL DESCRIPTION

The ZN450 utilises a charge-balancing conversion principle, which offers a number of advantages over the more common dual-slope integration method.

These include a fixed conversion time which is independent of the analogue input voltage, completely digital auto-zero and inherently bipolar operation. Linearity is also extremely good over the entire input voltage range, unlike some dual slope designs where stray capacitance can cause problems around zero.

The conversion time of the ZN450 is divided into two periods, measure and auto-zero, unlike the dual-slope system which has three distinct phases, signal integrate, reference integrate and auto-zero.

The heart of the ZN450 is the delta-sigma encoder, a simplified circuit of which is shown in figure 2.

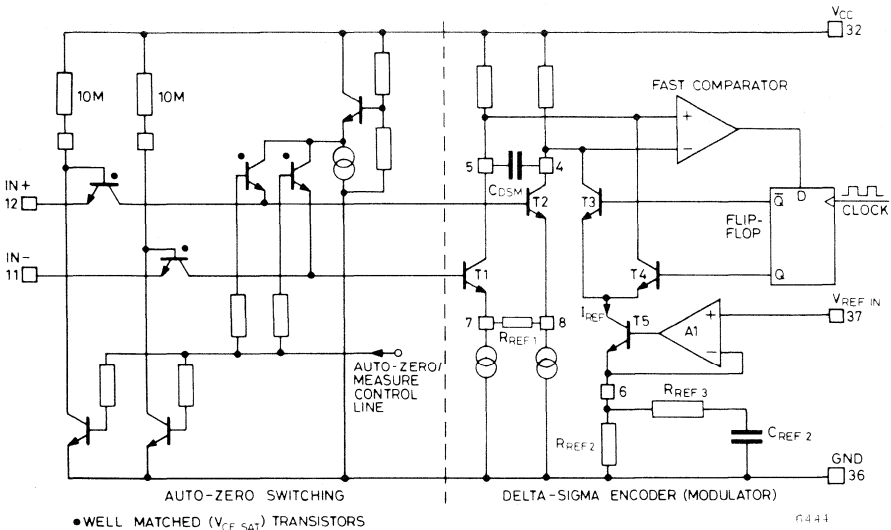

Fig. 2 – INPUT SWITCHING AND DELTA-SIGMA ENCODER

The delta-sigma encoder of the ZN450 consists of a voltage-current converter comprising T1 and T2, a reference current generator A1/T5 and a feedback loop containing a fast comparator, D-type flip-flop and current switches T3 and T4. These can switch a current $I_{REF} = \frac{V_{REF}}{R_{REF2}}$ into the collector circuit of either T1 or T2, depending on the state of the flip-flop.

The polarity of the voltage across capacitor C_{DSM} is monitored by the comparator, whose output is sampled on every clock pulse by the flip-flop. The outputs of the flip-flop switch I_{REF} into the collector circuit of either T1 or T2 so as to oppose the existing voltage on C_{DSM} i.e. to maintain the average charge acquired by C_{DSM} at zero, thus keeping the circuit in equilibrium.

Assuming perfect symmetry in the circuit, with zero volts applied between the bases of T1 and T2 their collector currents will be equal, and the only charge acquired by C_{DSM} will be that put on it by I_{REF} . The flip-flop will thus change state on every clock pulse so that C_{DSM} will alternately acquire charge quanta of $+I_{REF}T_C$ and $-I_{REF}T_C$ (where T_C is the clock period) and the nett charge acquired will be zero. The output of the flip-flop will thus be a square-wave with a 50% duty cycle.

ZN450E/CJ

During the measurement phase the voltage to be measured is applied between the bases of T1 and T2 and is converted into a current $I_{IN} = \frac{V_{IN}}{R_{REF1}}$ flowing in R_{REF1} . This produces a difference current $2I_{IN}$ in the collector currents of T1 and T2, so that the charge acquired by C_{DSM} is no longer equal and opposite ($\pm I_{REF}$) but is now $(I_{REF} - 2I_{IN}) T_C$ when T4 is turned on and $(-I_{REF} - 2I_{IN}) T_C$ when T3 is turned on.

In order to maintain equilibrium the flip-flop will now no longer change state on every clock pulse but will remain in one state for a longer period than it remains in the opposite state.

$$\text{i.e. } N_1 T_C (I_{REF} - 2I_{IN}) + (N - N_1) T_C (-I_{REF} - 2I_{IN}) = 0$$

where N_1 is the number of clock pulses for which the flip-flop output is a '1' and N is the total number of clock pulses over which the measurement is made and assuming N is so large that quantising error can be ignored.

$$\text{Thus } N_1 (I_{REF} - 2I_{IN}) = (N - N_1) (I_{REF} + 2I_{IN})$$

At this point it is perhaps worth noting that the DSM saturates (0% or 100% duty cycle) when I_{IN} is plus or minus $\frac{I_{REF}}{2}$

In order to provide an overload margin for series mode rejection the ZN450's DSM operates with a peak duty-cycle of nominally 10% for minus full-scale and 90% for plus full-scale ($I_{IN} = \pm \frac{2}{5} I_{REF}$) giving an overload margin of 25% of the full-scale input voltage.

$$\text{Now } \frac{2N_1 - N}{N} = \frac{2I_{IN}}{I_{REF}} \quad \text{i.e. } N_1 - \frac{N}{2} = \frac{N I_{IN}}{I_{REF}} = \frac{N V_{IN} R_{REF2}}{R_{REF1} V_{REF}}$$

What this means is that an up counter preset to $-\frac{N}{2}$ and allowed to count N_1 will accumulate a number proportional to V_{IN} , assuming N , R_{REF1} , R_{REF2} and V_{REF} are fixed. By suitable choice of these parameters $N_1 - \frac{N}{2}$ can be made directly equal to V_{IN} in volts or millivolts. Furthermore, by making the preset number greater or less than $\frac{N}{2}$ in proportion to any zero error in the system it is possible to provide a digital auto-zero.

The ZN450 indicates positive overrange at a count of +2000 when the duty cycle is 90% and $I_{IN} = \frac{2}{5} I_{REF}$. The required value of N can thus be obtained by substituting the overrange reading of 2000 for $N_1 - \frac{N}{2}$ and the corresponding value of $\frac{2}{5}$ for $\frac{I_{IN}}{I_{REF}}$, $2000 = \frac{2N}{5}$, $N = 5000$.

In fact the display counter is preceded by a +4 stage which is part of the auto-zero logic so the actual measurement period must be 20,000 clock periods to give a maximum of 5000 pulses at the display counter.

The display counter of the ZN450 can count from -5000 to +5000. It is preset to nominally -2500 during the auto-zero phase by allowing it to count from -5000 to -2500, as explained below.

Auto-Zero

Due to offsets and component mismatching in the delta-sigma encoder the displayed count accumulated for zero input voltage will not be zero. In order to remove this error and give a true zero reading for 0V input the ZN450 incorporates an auto-zero facility. This is completely digital in operation and there is no need to store the error as an analogue voltage on a capacitor, as is the case with some dual slope-designs. Furthermore the conversion period of the ZN450 comprises two well-defined phases, measure and auto-zero, unlike dual-slope DVMs which have signal integrate, reference integrate and auto-zero phases.

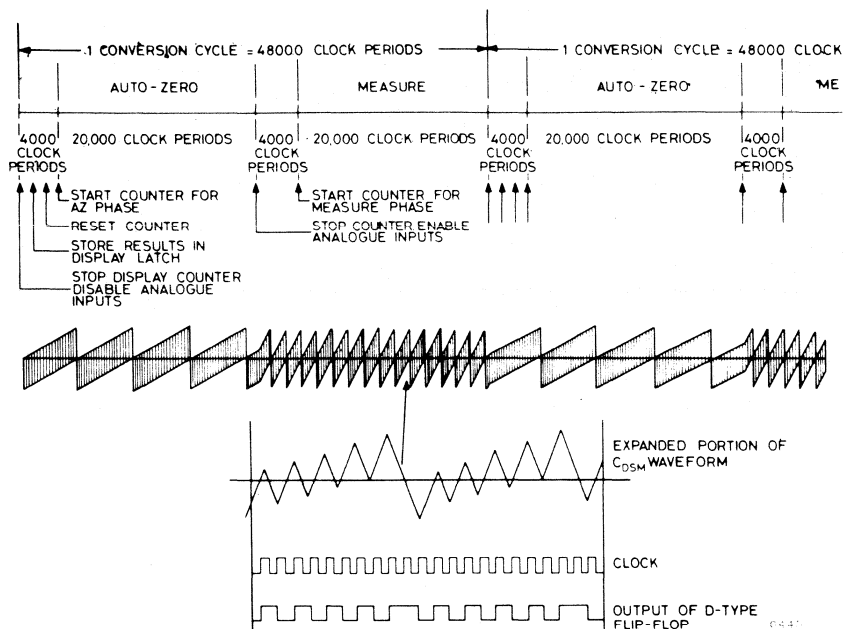

Fig. 3 – TIMING DIAGRAM OF ZN450

A timing diagram of the ZN450 is shown in figure 3. Its duration is 48000 clock periods and its two principal components are the measurement phase and the auto-zero phase which each occupy 20,000 clock periods. Each phase is separated by a space of 4000 clock periods to allow the input switches to settle. This also illustrates another advantage of the charge balancing conversion technique. Since the delta sigma encoder can run continuously without saturating and its average duty-cycle is always a measure of the input voltage, it is possible to allow the input switches to settle in this way before starting a measurement by activating the system counters.

Contrast this with the dual-slope DVM where the integrator capacitor begins to accumulate charge immediately the input voltage is connected. The system counter must start at the precise instant that the input voltage is connected which means that the input switches must be fast and noise-free. Furthermore termination of the measurement is determined by the comparator accurately detecting a single zero-crossing, so noise in the comparator or from other sources can cause errors. In the charge balancing DVM the comparator detects many zero crossings and noise tends to be integrated out.

Operation of the auto-zero system is best understood by considering what happens when an auto-zero phase is followed by a measurement with zero volts input. During the auto-zero phase the inputs of the DSM are disconnected from the analogue inputs and shorted to a point within common-mode range of the DVM. The counter is reset to -5000 and the system is allowed to run for 20,000 clock periods, but with the DSM output inverted. This means that the number of clock pulses counted will be, not N_1 but $(N - N_1)$. During the subsequent measurement with zero input voltage N_1 pulses will be counted, so that the total count will be N , i.e. 5000. The display counter will thus have counted from -5000 up to zero and zero will be displayed.

ZN450E/CJ

Due to the quantising error inherent in any digital measurement it is possible that the result of the measurement with zero input could differ from the result of the auto-zero by 1 count, thus giving rise to a zero error of ± 1 digit. To avoid this problem the ZN450 incorporates two guard bits in the form of a ± 4 stage and rounding up logic preceding the display counter. This means that although the display resolution is 1 part in ± 2000 the resolution of the measurement is four times better. Any zero error in the two (non-displayed) guard bits will not appear in the display and the logic also subdivides the zero state into $+0000$ and -0000 for true polarity indication.

As an additional benefit flicker in the last digit of the display is minimised.

Input Resistance

The input resistance of the ZN450 is determined by the two 10M bias resistors, the value of R_{REF1} , and h_{fe} and r_e of T1 and T2.

An equivalent input circuit is shown in figure 4. The input resistance comprises $h_{fe} (R_{REF1} + 2r_e)$ in parallel with 20M due to the two 10M input resistors.

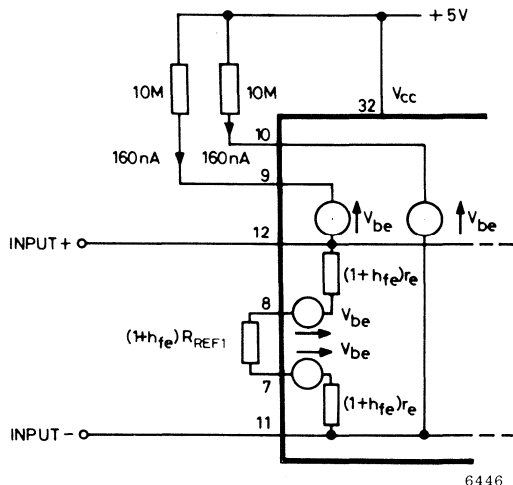

Fig. 4 – EQUIVALENT INPUT CIRCUIT OF ZN450

The h_{fe} of T1 and T2 is typically about 100 and r_e is around 2.5k, therefore:

$$R_{IN} = \frac{100 (R_{REF1} + 5k) \times 20M}{100 (R_{REF1} + 5k) + 20M}$$

For 200 mV full-scale, when $R_{REF1} = 200k$ the input resistance is around 10M.

Reference Loop and Supply Regulator

The reference current defining loop is shown in more detail in figure 5.

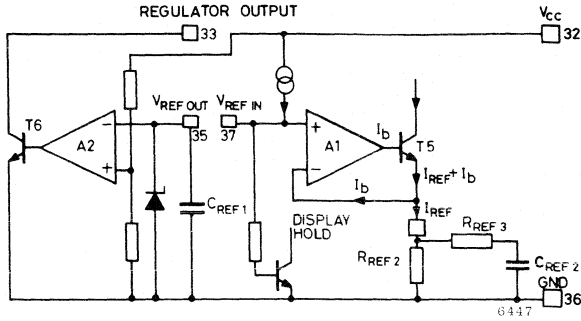

Fig. 5 – REFERENCE CURRENT LOOP AND SUPPLY REGULATOR

A reference input voltage applied to the non-inverting input of A1 causes the output of A1 to bias T5 such that the inverting input of A1 assumes the same potential and a current $\frac{V_{REF IN}}{R_{REF2}}$ flows in R_{REF2} . By making the input bias current of A1 the same as the base current of T5 this base current flows into the inverting input of A1 instead of through R_{REF2} . The reference current flowing in the collector of T5 is therefore almost identical to the current flowing in R_{REF2} . The reference loop is stabilized by C_{REF2} and R_{REF3} .

A highly stable on-chip bandgap reference of approximately 1.28V is provided and this may be used by linking $V_{REF OUT}$ to $V_{REF IN}$ when the reference will be biased on by the 150 μ A current source connected to the non-inverting input of A1. The on-chip reference is stabilised by C_{REF1} . The on-chip reference also provides the reference voltage for the on-chip supply regulator A2. This compares V_{REF} against $\frac{V_{CC}}{4}$ and controls V_{CC} with transistor T6 such that the two are kept equal, i.e. $V_{CC} \approx 5V$.

The supply regulator can be configured as a shunt or series regulator using only a few external components.

If $V_{REF OUT}$ is not connected to $V_{REF IN}$ but supply regulation is still required then the on-chip reference must be biased on by a 22k resistor to V_{CC} .

Setting Full-Scale Range

The described equation previously arrived at for the charge-balancing converter was:

$$\frac{N V_{IN} \cdot R_{REF2}}{V_{REF} \cdot R_{REF1}} = N_1 - \frac{N}{2}$$

i.e. displayed reading = $\frac{N V_{IN} \cdot R_{REF2}}{V_{REF} \cdot R_{REF1}}$

and since $N = 5000$

Displayed reading = $5,000 \frac{V_{IN} \cdot R_{REF2}}{V_{REF} \cdot R_{REF1}}$

or, substituting the maximum reading of ± 1999 and rearranging again:

$$V_{IN}(\text{full-scale}) = \frac{\pm 1999 V_{REF} \cdot R_{REF1}}{5000 \cdot R_{REF2}} \approx \frac{\pm 0.4 V_{REF} \cdot R_{REF1}}{R_{REF2}}$$

These equations are in fact not exact since they do not take account of the reference amplifier offset

ZN450E/C-J

voltage, which is typically $\pm 5\text{mV}$. This offset means that I_{REF} is not precisely $\frac{V_{\text{REF}}}{R_{\text{REF2}}}$, r_e of T1 and T2 in the voltage-current converter also appears in series with R_{REF2} (typically 5k). In practice this is not a problem since the tolerance of the on-chip reference means that a calibration adjustment must be provided anyway.

Using the on-chip reference voltage of 1.26 – 1.35 volts the recommended component values for a full-scale reading of 199.9 mV would be $R_{\text{REF1}} = 200\text{k}$, $R_{\text{REF2}} = 500\text{k}$ (min.), 520k (max.). Allowing for the use of 2% tolerance components for R_{REF1} and R_{REF2} an adequate adjustment range for calibration purposes will be provided if R_{REF2} is made up of a 470k resistor in series with a 100k multiturn trimmer. Full-scale ranges less than 200 mV can be accommodated by reducing the value of R_{REF1} , thus producing the same full-scale input current for a smaller input voltage. The limitations on the minimum value of R_{REF1} are caused by non-linearity in the voltage-current converter, offsets in the auto-zero switches, and the fact that r_e becomes a much larger proportion of R_{REF1} . These factors place a practical limit of about 20k on R_{REF1} .

Similarly full-scale ranges greater than $\pm 200\text{mV}$ can be accommodated by the value of R_{REF1} . The maximum input voltage that can be applied is limited by the common-mode range of the differential inputs. Provided the common-mode range of either input terminal is not exceeded the maximum differential voltage that can be applied between the inputs is about $\pm 2\text{V}$.

The full-scale range can also be adjusted by varying R_{REF2} which determines the reference current, and indeed placing a preset in series with R_{REF2} is the recommended method of calibration.

I_{REF} can also be varied by using an adjustable external reference voltage instead of the internal reference, which makes ratiometric operation possible.

The minimum value of I_{REF} is limited to about $3\mu\text{A}$ since above this value the voltage-current converter becomes non-linear. The maximum value of I_{REF} is not quite so well defined as it is determined by deterioration in the performance of current switches T3 and T4 at low collector currents. The minimum useable value of I_{REF} is typically 500 nA. This means that the upper and lower limits are $\frac{V_{\text{REF}}}{500\text{ nA}}$ and $\frac{V_{\text{REF}}}{3\mu\text{A}}$ respectively. The upper and lower limits on V_{REF} itself are determined by the common-mode range of the reference current amplifier A1 which is 1V to 1.5V. Ratiometric operation with a variable V_{REF} within these limits is possible provided that the upper or lower limit of I_{REF} is not exceeded.

Supply Voltage Options

The ZN450 is designed to be extremely flexible with regard to supply voltage and four power supply options are possible allowing operation over a wide range of supply voltages. These options are illustrated in figure 6.

The first option is to ignore the on-chip regulator and to connect an externally stabilised voltage of 4.5V to 5.5V direct to pin 32, for example a 5V logic supply.

For supply voltages greater than 6V the on-chip shunt regulator (pin 33) may be used by linking pins 32 and 33. When using the shunt regulator an external resistor must be placed in series with the supply to limit the regulator current as shown in figure 6b. The value of this resistor is given by:

$$R = \frac{V_{\text{supply}} - 5\text{ volts}}{5} \left(k, \frac{\text{V}}{\text{mA}} \right) \text{ which allows for the maximum 5 mA current consumption of the I.C.}$$

If the supply voltage is unstabilised then R should be calculated using the minimum supply voltage that will be encountered. The current drawn by this configuration increases with supply voltage as the shunt regulator sinks more current in order to maintain V_{CC} at 5V. The maximum allowable supply voltage is thus determined by the 15mA maximum rating of the shunt regulator, assuming very little current is drawn by the DVM circuitry, i.e.

$$\begin{aligned} V_{\text{max}} &= 15(\text{mA}) \times R(\text{k}\Omega) + 5\text{ volts} \\ &= (3V_{\text{min}} - 10)\text{ volts} \end{aligned}$$

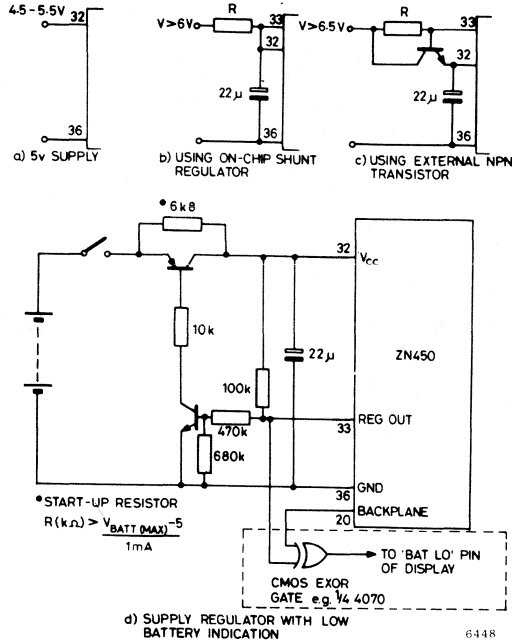

Fig. 6 – SUPPLY VOLTAGE OPTIONS

Since the current drawn by the shunt regulator increases with supply voltage this configuration is **not** recommended for battery operation where long battery life is a prime criterion, as the current drawn from a new battery could be up to three times the maximum current consumption of the DVM.

For battery operation a series regulator circuit is recommended which can be constructed using one or **two** external transistors controlled by pin 33. The simplest series regulator, shown in figure 6c, uses a single NPN transistor and allows operation down to about 6.5V. Current consumption of this circuit is the normal current consumption of the DVM plus the base current of the transistor.

The base resistor must be chosen such that it can supply sufficient base drive when the supply voltage is a minimum assuming

- (a) Maximum DVM current of 6.5 mA
- (b) Maximum shunt regulator voltage of 5.5V
- (c) Minimum gain of the transistor

$$\begin{aligned} \text{Now base current } I_b \text{ (mA)} &= \frac{V_{\min} - V_{\text{reg}} - V_{\text{be T1}}}{R_b} \\ \text{required base current} &= \frac{6.5 \text{ mA}}{h_{\text{fe}} \text{ (min)}} \\ \text{Therefore } R_b \text{ (k}\Omega\text{)} &= \frac{(V_{\min} - V_{\text{reg}} - V_{\text{be T1}}) \times h_{\text{fe}}}{6.5} \\ &\approx \frac{(V_{\min} - 6) \times h_{\text{fe}}}{6.5} \end{aligned}$$

ZN450E/CJ

Example. The circuit is to operate down to 6.5V with a transistor type whose minimum gain is 80

$$\begin{aligned}R_b &= \frac{(6.5 - 6) \times 80}{6.5} \\ &= 6.1k\end{aligned}$$

Nearest value of 5k6 is used.

Although a great improvement on the shunt regulator, the circuit of figure 6c still does not achieve maximum battery life since V_{\min} must always exceed the regulator voltage by $V_{be\ T1}$ plus the voltage drop across R_b .

For the ultimate in battery life the circuit of figure 6d is suggested. This allows operation down to voltages as low as $V_{\text{reg}} + V_{CE(\text{sat})\ T1}$ and, as an added bonus, it automatically detects the end of useful battery life, i.e. the point at which the regulator ceases to function.

T1 is a PNP series regulator transistor controlled by pin 33 via T2, which provides the required signal inversion. During normal operation the voltage drop across R1 is small since the base current required by T2 is only a few hundred nanoamps, and the voltage at pin 33 is not much above the V_{be} of T2 (about 0.6V).

When the battery voltage drops to $V_{\text{reg}} + V_{CE(\text{sat})\ T1}$ the voltage at the non-inverting input of the regulator amplifier will fall below V_{REF} and the shunt regulator output transistor will turn off causing the voltage at pin 33 to rise to about 80% of supply.

Pin 33 can conveniently be connected to a low battery indicator consisting of a CMOS EXOR gate, as shown in the dotted box. When pin 33 is low the output of the EXOR gate will be in phase with the backplane and the LO BAT indicator will be extinguished. When pin 33 is high the output will be out of phase with the backplane and LO BAT will be visible.

Oscillator Options

The on-chip oscillator of the ZN450 may be used with various configurations of external components, as shown in figure 7. It will operate with only an external capacitor, which may be fixed, or variable to adjust the oscillator frequency. Alternatively the frequency may be adjusted by placing a variable resistor in series with the capacitor. Graphs of oscillator frequency versus capacitor and resistor values are given in figure 8. If absolute accuracy of the oscillator frequency is required then a crystal or ceramic resonator may be used as the frequency determining element. By making the integration time a whole number of mains cycles a degree of mains interference rejection can be provided. For example a 100 kHz crystal gives an integration time of 200 ms which is 10 cycles at 50 Hz mains frequency or 12 cycles at 60 Hz, the total measurement interval being 480 ms or just over two conversions/second.

If mains interference is superimposed on the input signal it is important that its peak amplitude should be less than 25% of full-scale to avoid saturation of the DSM. If this is not the case then the ZN450 should be preceded by a lowpass filter to give additional mains rejection.

The final option is to overdrive the oscillator input from a TTL or CMOS gate, as shown in figure 7d.

In order to maintain an adequate drive to the comparator the value of C_{DSM} must also be changed in proportion to the oscillator period. A table of suitable values is given below.

Oscillator frequency (kHz)	C_{DSM}	
	Min.	Max.
50	200n	2 μ
100	100n	1 μ
150	68n	680n

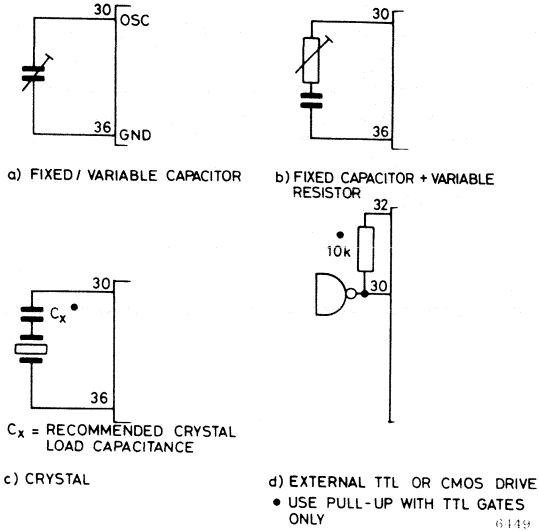

Fig. 7 – OSCILLATOR OPTIONS

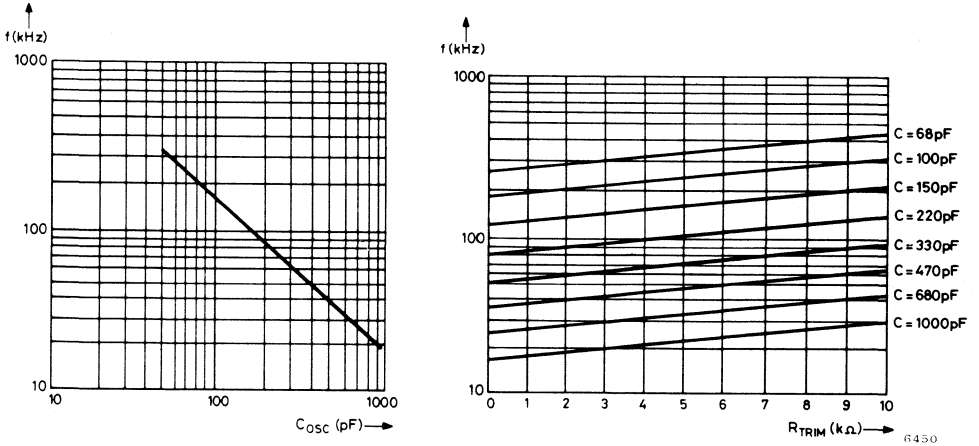

Fig. 8 – OSCILLATOR FREQUENCY vs EXTERNAL CAPACITOR AND RESISTOR

ZN450E/CJ

Range Output

To simplify the design of auto-ranging instruments, underrange and overrange detection circuits are provided in the ZN450. Overrange is indicated when the count exceeds 1999, whilst underrange is indicated for counts less than 150. This provides a degree of hysteresis to prevent the instrument jittering between ranges, which could occur if underrange was indicated at a count of 199 and there was a mismatch in the attenuators or other signal conditioning circuits.

Because the pins of the ZN450 are fully utilised it is not possible to provide separate underrange and overrange pins, so a single three-state output is provided.

If the measurement is in range then pin 19 will be at $\frac{V_{CC}}{2} \pm 0.5V$ with a source resistance of approx. 40k.

For an overrange measurement pin 19 will go HIGH for 1000 clock pulses synchronous with the data store pulse at the end of the measurement. For an underrange measurement pin 19 will pulse LOW in a similar manner. In each case the output resistance is approx. 80k.

The range output can be fully decoded using a dual comparator, as shown in figure 9.

A visual overrange indication is also provided. In this condition the leading digit of the display shows a '1' whilst all other digits are blanked.

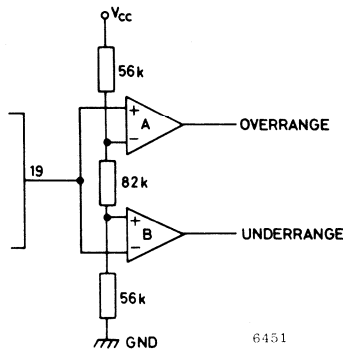

Range Output	Output A	Output B
Underrange (GND)	0	⌋
In Range ($\frac{1}{2}V_{CC}$)	0	0
Overrange (V_{CC})	⌋	0

Fig. 9 – DECODING THE RANGE OUTPUT

Display Hold

The reference input, pin 37, also doubles as a display hold pin. If this pin is grounded then the display will continue to show the results of the last valid measurement until pin 37 is released. Display hold also resets the system counters and a new measurement begins immediately display hold is released. The method of activating display hold depends on whether or not the on-chip reference and shunt regulator are being utilised.

If an external reference voltage is used (pins 35 and 37 not joined) then display hold can be activated by grounding pin 37 with a single-pole switch, transistor or open-collector logic gate, provided that the external reference is not required to supply other circuits. If the on-chip regulator is to be used then pin 35 must, of course, be biased up with an external 22k resistor so that V_{REF} can supply the reference voltage for the regulator. If the on-chip reference is used but the on-chip regulator is not then display hold can be activated in a similar manner by grounding the junction of pin 35 and pin 37.

However, since the on-chip reference also provides the reference voltage for the on-chip regulator pin 35 must not be grounded if the regulator is in use or the supply voltage will drop to zero. If the on-chip reference and shunt regulator are both used then pin 37 must be disconnected from pin 35 before it is grounded to activate display hold. This is illustrated in figure 10. As pin 37 normally supplies the bias current for the on-chip reference this must be provided by an external 22k resistor when these pins are not linked.

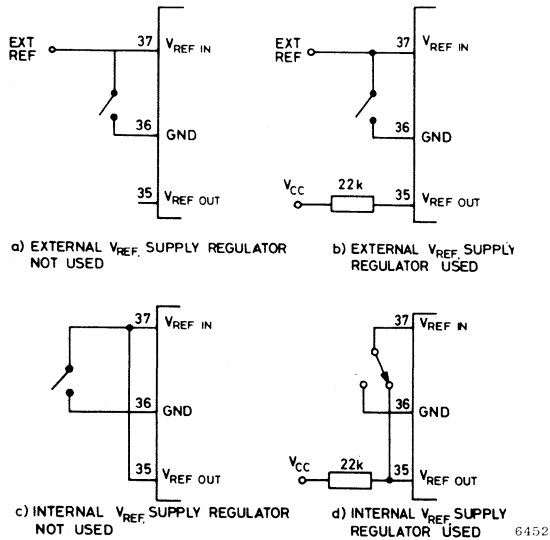

Fig. 10 – DISPLAY HOLD OPTIONS

Backplane Output

The backplane output normally provides a squarewave of the same frequency as, but 180° out of phase with, the active segment outputs. This provides the necessary a.c. drive to the L.C. display. By grounding the backplane output the a.c. drive to the segments may be inhibited and the segment outputs become normal active low (TRUE = 0) outputs. This facility is useful if the output data is to be used for some purpose other than display driving. An L.C. display should not be connected to the ZN450 in this condition as d.c. drive will eventually damage it.

ZN450E/CJ

Decimal Point Drive

The ZN450 provides all the outputs necessary to drive the segments of a 3½ digit liquid crystal display. However, in order to drive decimal points and annunciators such as low battery indicators, some external components are required. To turn on a decimal point it is necessary to provide it with a drive signal of the same frequency as, but 180° out of phase with, the backplane output. For driving a single, fixed decimal point, the simple inverter circuit of figure 11a can be used.

If more than one decimal point is to be selected then it is necessary for the unused decimal points to be switched off by arranging their drive waveforms to be in phase with the backplane output. This is simply achieved using exclusive OR gates as shown in figure 11b.

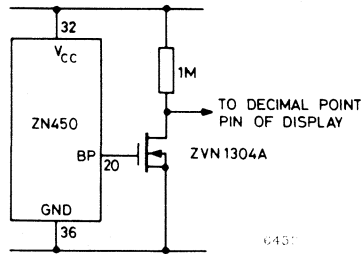
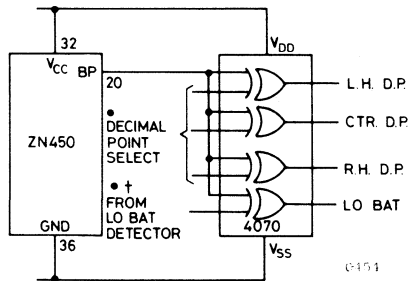

Fig. 11a – DRIVING A FIXED DECIMAL POINT



*Logic 1 = ON
 Logic 0 = OFF
 †See also figure 6

Fig. 11b – DECIMAL POINT SELECT AND 'LO BAT' INDICATOR DRIVE USING EXCLUSIVE OR GATES

A logic '1' on the input causes the output waveform to be out of phase with the backplane and the appropriate decimal point is activated. Conversely a logic '0' causes the output to be in phase with the backplane. A single 4070 CMOS quad-EXOR gate I.C. will provide the drive for the three decimal points of a 3½ digit liquid crystal display plus the drive to a low battery indicator. A suitable low battery detection circuit is shown in figure 6d.

External Components

A basic 200 mV DVM can be built using only ten external passive components, as shown in figure 12. In addition to these components it is good practice to include input protection resistors to limit the maximum input current to 50 mA in the event of an input overload. The resistance and power rating of these components depends on the maximum voltage against which the inputs are to be protected.

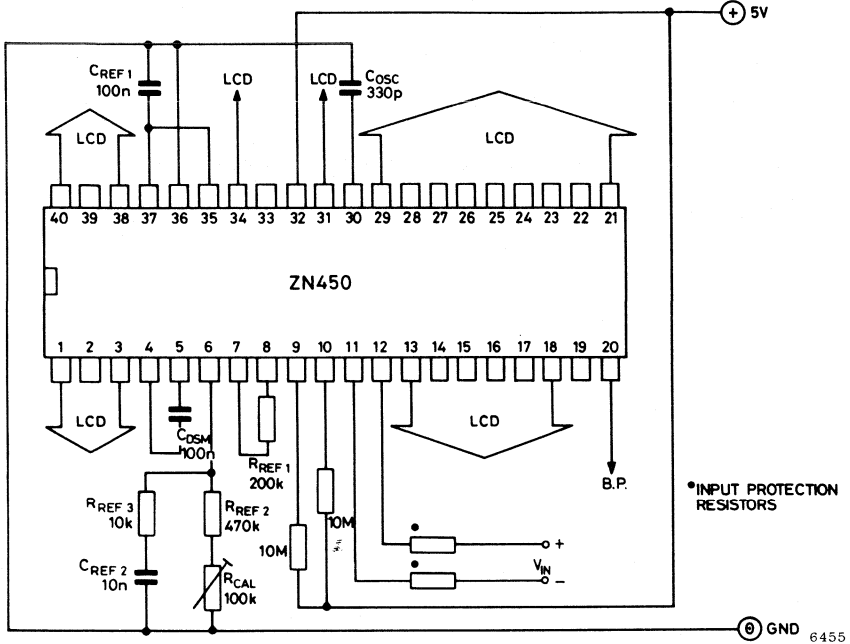

Fig. 12 – EXTERNAL COMPONENTS FOR A BASIC 200mV DVM WITH 5V SUPPLY

Signal Conditioning

The ZN450 can be used with a wide variety of signal conditioning circuits and transducers to provide a digital display of any parameter that can be converted into a suitable d.c. voltage.

Voltage Measurement

The most obvious signal conditioning circuit is a switched input attenuator which will allow d.c. voltages greater than 200 mV to be measured. To minimise time-consuming calibration procedures it should be possible to calibrate the DVM on only one range and to rely on the precision of the attenuator resistors to give accurate results on other ranges.

However, since the input resistance of the ZN450 is about 10 MΩ its loading effect on the attenuator cannot be ignored. Fortunately this effect can be eliminated by designing an attenuator with a constant output resistance so that the ZN450 sees the attenuator as a 199.9 mV (full-scale) source with a constant source resistance on all ranges.

Three suitable types of attenuator circuit are shown in figure 13, a ladder attenuator and two types of T attenuator. The ladder attenuator has the advantage that the input resistance is fairly constant and only 3 resistor values are required, but the switching is somewhat complicated.

ZN450E/CJ

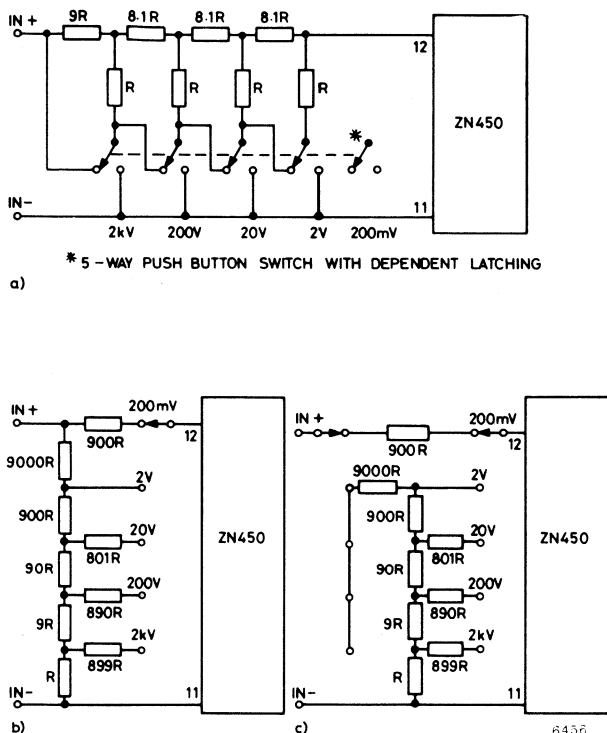

Fig. 13 – ATTENUATORS FOR MULTIRANGE VOLTMETER

The T attenuator of figure 13b has the advantage of simplicity, using only a single-pole switch, but the resistor values are slightly odd. Furthermore the input resistance drops to about $5\text{ M}\Omega$ on the 200 mV range since the attenuator appears in parallel with the ZN450's input resistance. This problem can be overcome by using a two-pole switch so that the attenuator is disconnected on the 200 mV range as shown in figure 13c.

When designing signal conditioning circuits for use with the ZN450 care must be taken to ensure that the input offset current does not cause errors. The offset current generates an error voltage $I_{OS} \times R_O$ where R_O is the output resistance of the attenuator. There are two components in the offset current; that due to the ZN450 itself, typically 100 pA , and a component due to the mismatch of the $10\text{ M}\Omega$ input resistors, typically 150 pA per $\text{k}\Omega$ mismatch. The offset current can be minimised by using well matched $10\text{ M}\Omega$ resistors, or can be nulled out entirely using the circuit of figure 14.

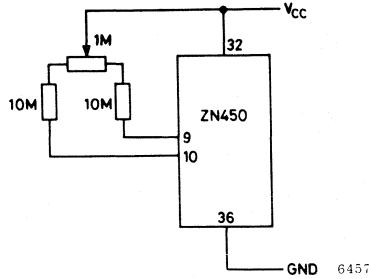

Fig. 14 – OFFSET CURRENT NULLING CIRCUIT

Current Measurement

Measurement of d.c. current is also very simple. The current to be measured is allowed to flow through a shunt resistor connected across the input terminals of the ZN450, the voltage measured being equal to the product of the current and the shunt resistors.

Currents as low as $20\ \mu\text{A}$ full-scale can be measured before the input resistance and offset current of the ZN450 become significant.

For multi-range current measurement the preferred circuit is the so-called universal shunt, an example of which is shown in figure 15.

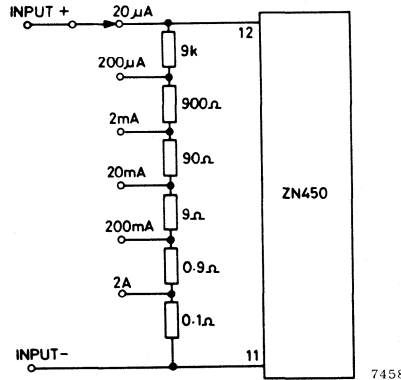

Fig. 15 – MULTIRANGE AMMETER CIRCUIT USING UNIVERSAL SHUNT

Although the full-scale voltage drop of this circuit is 200 mV it is perfectly feasible to design an ammeter with a smaller voltage drop by increasing the sensitivity of the ZN450. This has two advantages. Firstly, the voltage loss in the ammeter is reduced, which can be useful when making measurements in low-voltage circuits. Secondly, the power dissipation in the shunt resistors is reduced.

Example:

Measuring 20A full-scale with a 200 mV voltage drop the required shunt resistor will be $\frac{0.2}{20} = 10\ \text{m}\Omega$ and the full-scale power dissipation will be 4 watts. With a 20 mV drop the required resistor will be $1\ \text{m}\Omega$ and the power dissipation 400 mW.

ZN450E/CJ

Transducer Bridge Circuits

The high sensitivity and true differential inputs of the ZN450 make it ideal for use with transducers, particularly those which function best in a bridge configuration. The regulated 5V supply can also provide a stable excitation voltage for passive transducers such as semiconductor pressure gauges, platinum resistance thermometers and semiconductor temperature sensors.

Figure 16 shows a thermometer circuit using a silicon diode as the temperature sensor. The forward voltage drop has a temperature coefficient of approximately $-2\text{ mV}/^\circ\text{C}$ when the device is run at a constant current. In the bridge circuit shown this gives an increase of about $1.28\text{ mV}/^\circ\text{C}$ at the + input of the ZN450. The full-scale reading of the ZN450 is set to about 256 mV so that one digit corresponds to 0.1°C and the full-scale reading is 199.9°C .

The bridge configuration allows the forward voltage drop of the diode to be nulled out using P1 to give a reading of 000.0 at 0°C , whilst P2 adjusts the full-scale range of the ZN450 to read 100.0 at 100°C .

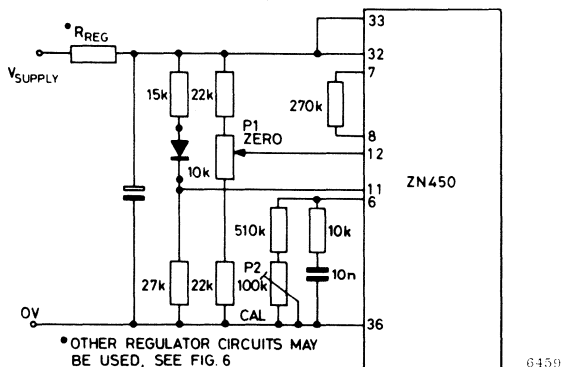

Fig. 16 – DIGITAL THERMOMETER CIRCUIT

Common-Mode Performance

The ZN450 has true differential inputs with a common-mode range of 1.8 – 1.3 volts and good common-mode rejection. However, if the full potential of the differential inputs is to be realised then care must be taken when designing with the ZN450.

When open-circuit, the inputs of the ZN450 are biased at about 2.8 volts above supply common. If a common-mode voltage other than this is applied to the inputs then care must be taken to ensure that any impedances between the inputs and the common-mode voltage (attenuators, series resistors, etc.) are the same for each input, otherwise the common-mode rejection will be impaired. This is illustrated in figure 17. Balancing the input of impedances of differential inputs to ensure good common-mode rejection is, of course, normal practice.

This is generally a problem only in systems where the voltage to be measured is referenced to the ZN450's supply ground. In battery-powered applications no common-mode voltage exists between the measured voltage and the inputs, since the supply voltage of the ZN450 is floating. However, care must be taken in battery-powered systems to ensure good a.c. rejection.

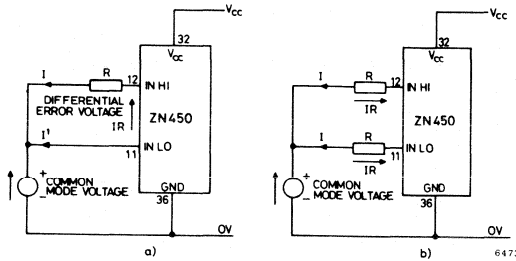

Fig. 17 – (a) UNBALANCED INPUT RESISTANCES IMPAIR COMMON-MODE REJECTION.

(b) WITH BALANCED INPUT RESISTANCES COMMON-MODE VOLTAGE DOES NOT CAUSE DIFFERENTIAL ERROR VOLTAGE.

If the voltage being measured has a large a.c. common-mode signal superimposed upon it then the supply voltage of the ZN450 will normally float up and down with the a.c. component, thus keeping the inputs of the ZN450 within their common-mode range. However, the resistance between the a.c. signal at the inputs and the ZN450 supply rails is the $5M\Omega$ common-mode resistance of the ZN450 inputs. If significant stray capacitance exists between the ZN450 supplies and ground (for example if the battery is close to an earthed metal surface) then this can form a low pass filter with the common-mode input resistance with the result that the ZN450 supply rails do not follow the a.c. common-mode voltage at the inputs. This is shown in figure 18.

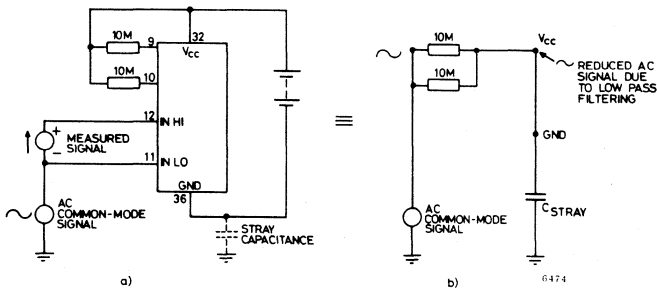

Fig. 18 – (a) BATTERY-POWERED ZN450 CONNECTED TO SIGNAL WITH LARGE A.C. COMMON-MODE SIGNAL. (SUPPLY REGULATOR NOT SHOWN).

(b) EQUIVALENT A.C. CIRCUIT.

The problem can be overcome in one of two ways. The simpler method, shown in figure 19a, is to connect a capacitor between input low and supply ground. This provides a low impedance a.c. path between these two points so that the supply rails will track the a.c. common-mode voltage.

ZN450E/CJ

The value of this capacitor should be several times greater than the maximum stray capacitance. On the other hand, at switch-on it must charge up via the 10M input resistance of the ZN450, so it should not be too large. A value of 22n is about the optimum.

An alternative solution is to mount the DVM in a screened enclosure, the screening being connected to input LO. This has the effect of producing a stray capacitance between the ZN450 supply rails and screen. However, since the screen is not at a fixed potential, but follows the common-mode signal, the effect of this capacitance is bootstrapped out.

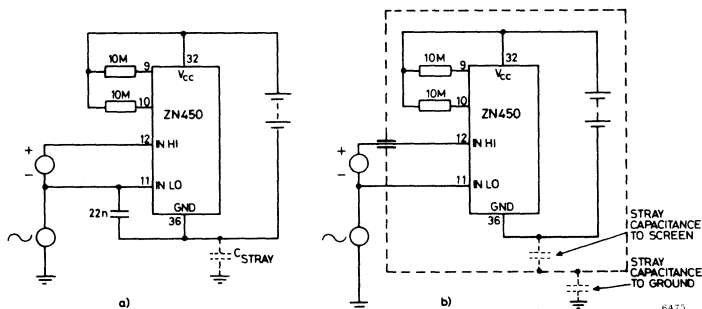

Fig. 19 – TWO METHODS OF ENSURING A.C. REJECTION IN BATTERY-POWERED CIRCUITS.

A.C. Measurements

To measure a.c. voltage or current it is first necessary to convert it into a proportional d.c. voltage. The simplest way to do this is to interpose a precision active rectifier circuit between the attenuator or shunt and the inputs of the ZN450. Such a circuit produces d.c. voltage proportional to the mean of the rectified voltage rather than a true R.M.S. result and for true R.M.S. measurements an R.M.S. converter must be used. The rectifier can be calibrated to read R.M.S. but the result is true only if the input signals have a constant form factor.

A simple precision rectifier circuit is shown in figure 20. It is completely a.c. coupled throughout by C2, C3 and C4, so the offset voltage of A1 does not appear at the output and no zero adjustment is required. To prevent the offset voltage of A1 causing it to saturate in the absence of an input signal, 100% d.c. feedback is provided by R3.

R1 and R2 provide a d.c. bias path for the non-inverting input of A1, whilst C2 provides bootstrapping to increase the a.c. input impedance.

Amplifier A2 is a voltage follower biased into the middle of the ZN450's common-mode range to provide a low impedance analogue common point. The output of the rectifier is connected to a lowpass filter comprising R6 and C5. So that both inputs of the ZN450 see the same d.c. resistance R6 is placed in series with the input LO terminal and is made equal to R4 + R5. This in no way affects the performance of the filter. With the component values shown the circuit is calibrated to read R.M.S. for sinewave inputs, so the use of this type of waveform will be assumed throughout.

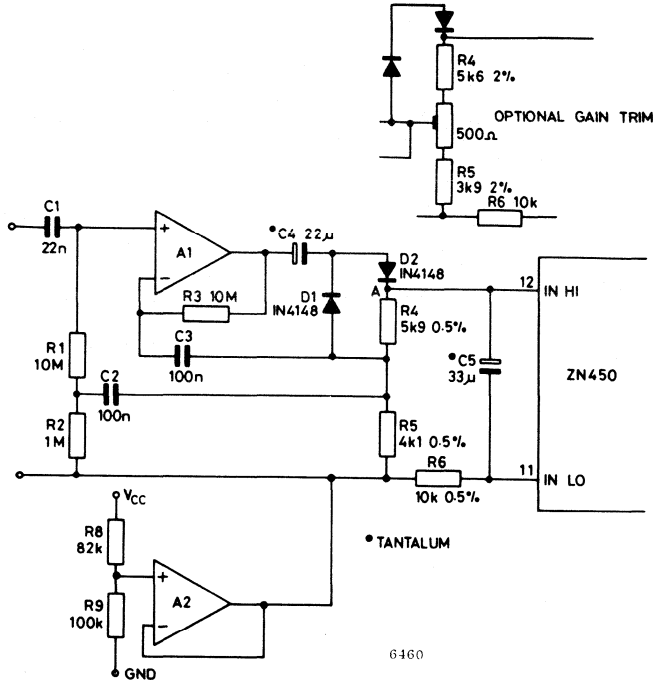

Fig. 20 – PRECISION RECTIFIER FOR A.C. MEASUREMENTS

The circuit functions as follows: when the input signal crosses zero in a positive going direction the output of A1 slews positive until D2 conducts after which the voltage at point A is defined by the equation:

$$V_A = G \times V_{IN}, \text{ where } G = \frac{R_4 + R_5}{R_5}$$

and since

$$R_6 = R_4 + R_5$$

$$G = \frac{R_6}{R_6 - R_4}$$

and

$$R_4 = R_6 \left(\frac{G - 1}{G} \right)$$

This voltage tends to charge up C₅ in a positive direction via R₆. When the signal crosses zero in a negative going direction the output of A1 slews negative until D1 conducts, after which the output voltage at point B is equal to (minus) V_{IN}. This voltage tends to charge up C₅ in a negative direction via R₆ and R₄.

Now, assuming the time constant R₆/C₅ is long compared to the period of the input waveform, the voltage on C₅ will eventually reach equilibrium. When this is the case the mean current flowing into C₅ during the positive half cycle must equal that flowing out of C₅ during the negative half cycle.

i.e.
$$\frac{V_{A(MEAN)} - V_C}{R_6} = \frac{-V_{B(MEAN)} + V_C}{R_6 + R_4}$$

ZN450E/CJ

Now the mean value of a rectified sinewave signal is 0.9 times the R.M.S. value therefore

$$V_{A(\text{MEAN})} = 0.9 \cdot G \cdot V_{IN(\text{RMS})}$$

and

$$V_{B(\text{MEAN})} = -0.9 V_{IN(\text{RMS})}$$

In order for the ZN450 to read correctly V_C must equal V_{RMS} therefore

$$V_A = 0.9 \cdot G \cdot V_C$$

and

$$V_B = -0.9 V_C$$

therefore

$$\frac{V_C(0.9G - 1)}{R_6} = \frac{1.9V_C}{R_6 + R_4}$$

substituting for R_4 and eliminating V_C

$$\frac{0.9G - 1}{R_6} = \frac{1.9}{R_6 + R_6 \frac{(G - 1)}{G}}$$

eliminate R_6

$$\begin{aligned} 0.9G - 1 &= \frac{1.9G}{2G - 1} \\ (0.9G - 1)(2G - 1) &= 1.9G \\ 1.8G^2 - 4.8G + 1 &= 0 \end{aligned}$$

Solving the above quadratic equation gives

$$G = 2.439$$

or $R_4 = 0.59R_6$

$$R_5 = \frac{R_6}{2.439}$$

These equations allow the values of R_4 and R_5 to be calculated for any value of filter resistor R_6 . With the values shown the circuit is accurate to about $\pm 1.5\%$ over the frequency range 40 Hz to 1 kHz.

Ordering Information

Type Number	Package	Operating Temperature Range
ZN450E	Plastic	0°C to +70°C
ZN450CJ	Ceramic	0°C to +70°C

PIN CONNECTIONS

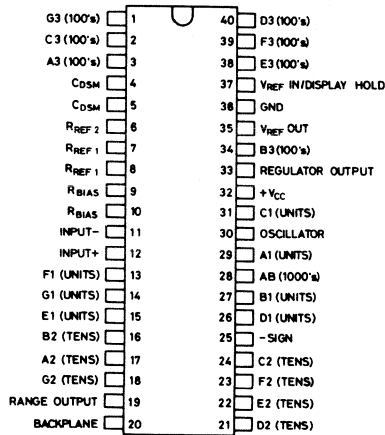

6461

CHIP DIMENSIONS AND LAYOUT

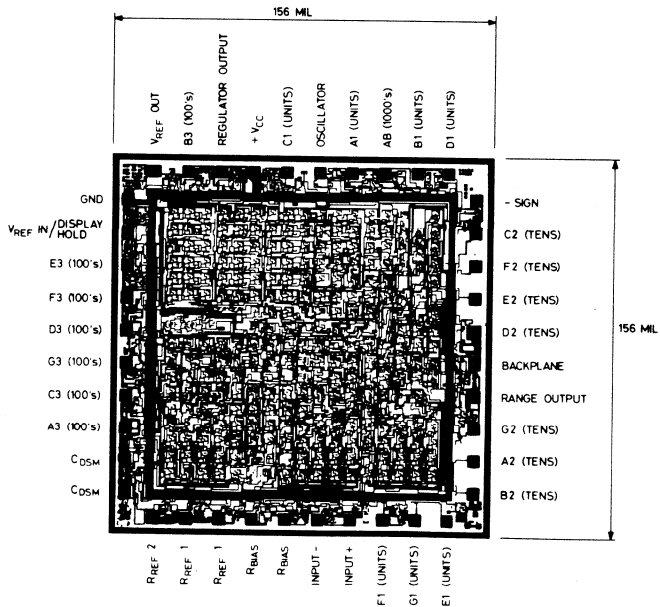



Low Power $3\frac{1}{2}$ Digit D.V.M. Integrated Circuit

FEATURES

- $3\frac{1}{2}$ Decade display (± 1999 max. reading)
- Automatic polarity detection and indication
- Leading zero suppression
- Overload indication
- Multiplexed B.C.D. outputs capable of driving a T.T.L. decoder/driver directly (e.g. ZNA7447A)
- External input to blank display
- Internal oscillator, adjustable externally
- An output at $1/100$ clock frequency for under range indication, or for synchronising the clock frequency for optimum mains rejection
- Single rail, 5 volt supply operation (at 10 mA typical)

GENERAL DESCRIPTION

The ZNA116E allows a precision $3\frac{1}{2}$ digit D.V.M to be constructed very easily. It provides all the control logic necessary for a D.V.M using the well known dual slope integration technique. The low power requirements of the device make it attractive for portable battery operated applications and, since it is bipolar, requires no special handling precautions.

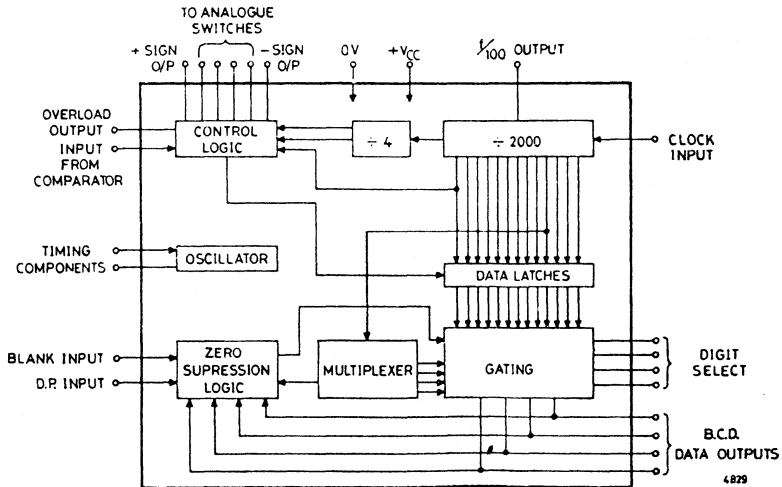

System Diagram

ZNA116E

PINNING AND FUNCTIONAL DETAILS

Pin number	Name	Function
1	Earth	Supply 0 volts
2	f/100 output	An output at $1/100$ of the clock frequency is available at this pin.
3	Clock input	An external clock can be applied at this pin, or the internal oscillator can be used by linking it to pin 14. A measurement is made every 8000 clock periods. Transfer of a number to the latches occurs at the first $-VE$ going clock edge after comparison has been made. The counter toggles on $+VE$ going clock edges. Max. clock frequency = 50 kHz, Min. logic 0 time at clock input = 8 μ sec.
4	M1	Digit drive output. When this output is low, the most significant digit is displayed.
5	M2	Digit drive output. When this output is low, the second most significant digit is displayed.
6	M3	Digit drive output. When this output is low, the third most significant digit is displayed.
7	M4	Digit drive output. When this output is low, the least significant digit is displayed. The multiplexed frequency = $1/40$ clock frequency.
8	Blank input	When this input is held at logic 1, the data outputs, A,B,C,D, will also all be at a logic 1. This is detected by the T.T.L. decoder/driver and the display is switched off.
9	D.P. input	When this input is at logic 1, leading zeroes are blanked off. Pins 5 and 6 can be wired to the D.P. input to give the correct display, when a decimal point is displayed. (see diagrams).
10	A	2^0 BCD data output
11	B	2^1 BCD data output
12	C	2^2 BCD data output
13	D	2^3 BCD data output
14	Oscillator output	Link to pin 3 if internal oscillator is to be used.
15	Oscillator input	External components, connected to this pin, control oscillator frequency. (see figure 1).
16	$+VE$ reference switch output	When this output is at logic 1, it connects the $+VE$ reference voltage into the integrator.
17	$-VE$ reference switch output	When this output is at logic 1, it connects the $-VE$ reference voltage into the integrator.
18	$-$ Sign output	This output is at logic 1 when a negative input voltage is being measured.

PINNING AND FUNCTIONAL DETAILS

Pin number	Name	Function
19	+Sign output	This output is at logic 1 when a positive input voltage is being measured.
20	Comparator input	This input is connected to the output of the external comparatior.
21	Signal switch output	When this output goes to logic 1, it connects the voltage to be measured into the integrator.
22	V _{CC}	Supply +5 volts.
23	Reset switch output	When this output is at logic 1, the switch across the integrator capacitor is turned on to completely discharge it.
24	Overload output	If the integrator capacitor does not discharge completely until after the counter has reached 2000, this output will go to logic 1.

ZNA116E

TECHNICAL DATA

(a) Maximum Ratings:

Supply voltage	5.5 volts
Operating temperature	0°C to +70°C
Storage temperature	-55°C to +125°C

(b) Electrical Characteristics ($T_A = 0^\circ\text{C}$ to $+70^\circ\text{C}$)

Parameter	Min.	Typ.	Max.	Units	Test conditions
Supply voltage V_{OC}	4.75		5.25	Volts	
Supply current I_{CC}			15.0	mA	$V_{CC} = 5$ volts
Logic 0 level All input pins except pin 15 V_{IL}			0.8	Volts	
Logic 1 level All input pins except pin 15 V_{IH}	2.0			Volts	
High-level input current All input pins except pin 15 I_{IH}			4.0	μA	$V_{in} = V_{CC}$
Low-level input current All input pins I_{IL}			-4.0	μA	$V_{in} = 0\text{V}$
Logic 0 level Output pins 2,4,5,6,7,10, 11,12,13 V_{OL}			0.4	Volts	$I_{sink} = 1.6$ mA
Logic 0 level Output pins 14,18,19,21,24 V_{OL}			0.4	Volts	$I_{sink} = 1.0$ mA
Logic 0 level Output pins 16,17,23 V_{OL}			0.4	Volts	$I_{sink} = 0.5$ mA
Logic 1 level All output pins except pin 14 V_{OH}	2.4			Volts	$I_{out} = 10$ μA
Oscillator frequency		20.0		kHz	With timing components shown in figure 1
Temperature coefficient of oscillator		± 0.02		% per $^\circ\text{C}$	Excluding temp. coefficient of the external timing components
Variation in oscillator frequency with changes in V_{CC}		-0.4		% per volt	$T_A = 25^\circ\text{C}$

(c) Notes:

- Pin 14 is an open-collector output. All other outputs have a nominal 100 k Ω pull-up resistor to V_{CC} rail.
- Although the oscillator and logic will function up to 50 kHz, this is not recommended as the analogue circuitry becomes more critical.

OSCILLATOR CIRCUIT

RECOMMENDED COMPONENTS FOR 20 kHz OPERATION

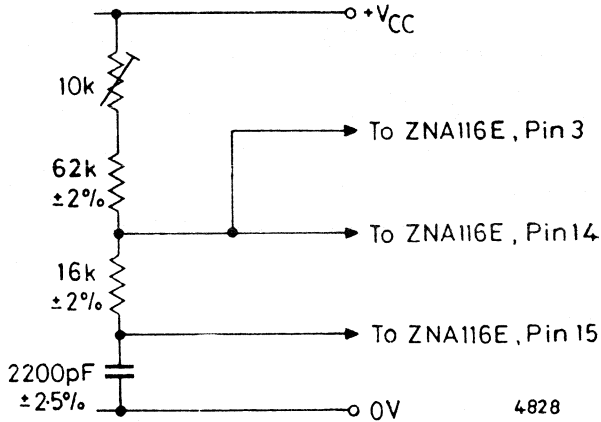

Figure 1.

Notes:

- (a) Oscillator stability is better than 0.02% per °C.
- (b) The potentiometer should be set so that the frequency of oscillation is 20 kHz. This is best monitored at pin 2, to avoid loading the oscillator while setting up.
- (c) The potentiometer and the 62k resistor can be replaced by a single 68k $\pm 2\%$ high stability resistor at the loss of some mains rejection only.

THE DUAL SLOPE SYSTEM

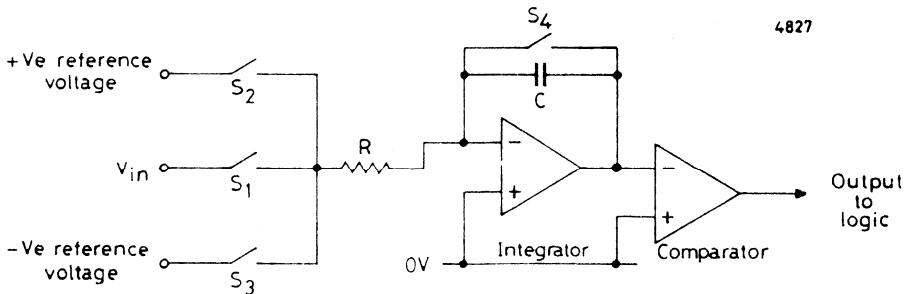

Figure 2.

(Refer to timing diagram, figure 3)

ZNA116E

At time T_1 ; S2, S3 and S4 are open and S1 closes to apply the input voltage, V_{in} , to the integrator. The integrator capacitor, C, charges up linearly until time T_2 which is 4000 clock periods after T_1 . The voltage at the integrator output, V_x , at time T_2 is proportional to V_{in} .

At time T_2 , S1 is opened and either S2 or S3 is closed, to apply a reference voltage, of the opposite polarity to V_{in} , to the integrator, Thus C is made to discharge at a constant rate and at time T_3 the output voltage of the integrator will again be zero. This is detected by the comparator and the reference voltage is now switched off and the number of clock pulses corresponding to T_x will be transferred to latches and displayed. This number is proportional to V_x and hence is proportional to V_{in} . If T_x exceeds 2000 clock periods, an overload condition is indicated.

At time T_4 , which is 3000 clock periods after T_2 , S4 closes to completely discharge the capacitor. At time T_5 , which is 4000 clock periods after T_2 , S4 opens and the cycle is repeated.

If S1 is closed for a time which is a multiple of 20 msec., any 50 Hz mains ripple superimposed on V_{in} will be integrated to zero and thus good mains rejection is obtained.

The dual slope D.V.M. does not require a high stability capacitor or high stability oscillator (unlike single slope systems) to achieve high accuracy.

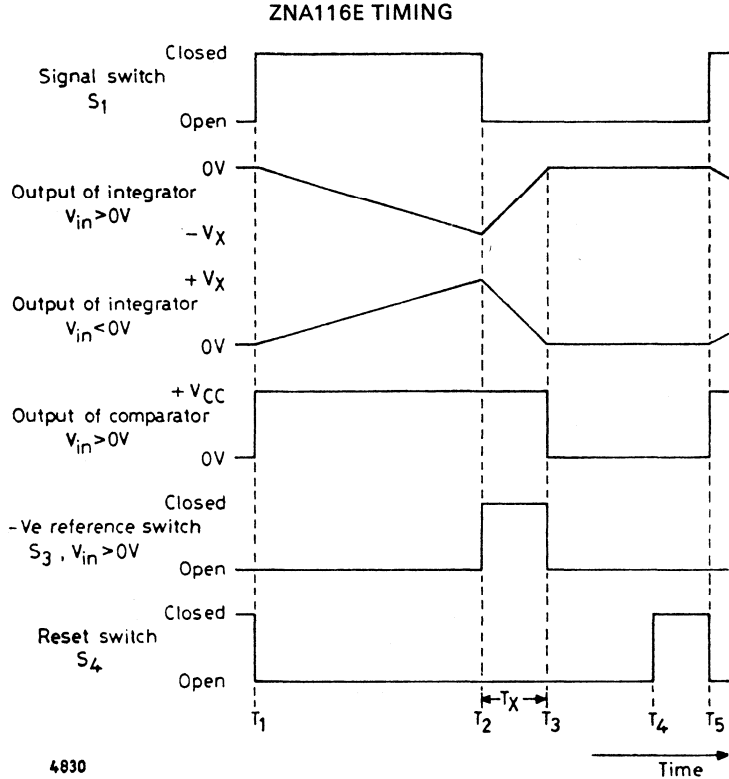

4830

Figure 3.

ZNA116E

THE DESIGN OF D.V.M. CIRCUITS USING THE ZNA116E

The ZNA116E provides the control logic necessary to construct a D.V.M. with a $3\frac{1}{2}$ digit display having an accuracy of $\pm\frac{1}{2}$ digit. The actual accuracy obtained will depend on four factors:

- (a) Accuracy of calibration.
- (b) Stability of reference sources.
- (c) Stability of transistor switches.
- (d) Operational amplifier drift.

The circuit details are given for the construction of a simple D.V.M. circuit which runs off a single 5 volt supply rail. The accuracy of this D.V.M., typically $0.1\% \pm 1$ mV., (on the 1v. range) should be adequate for many applications.

To achieve this accuracy, the nominal 5 volt supply rail should be held stable to ± 50 mV. An I.C. voltage regulator is ideal for this purpose.

The main factor limiting the performance of this circuit is (d). If a better performance is required, an amplifier with a lower bias current must be used (e.g. ZN741) running on ± 5 volt supply rails, so that the drift becomes less significant. More elaborate interfacing with the ZNA116E will be required in this case.

D.V.M. CONSTRUCTION

Due to the clearly defined application of the ZNA116E, the full circuit is given for a simple $3\frac{1}{2}$ digit D.V.M. together with full printed circuit board details.

The construction is defined in two distinct halves: an analogue board containing integrator, comparator, reference supplies and transistor switches; and a digital board containing the ZNA116E, display, driver and oscillator components. This allows the constructor the chance to alter the 'front end' (analogue circuit) if desired, without disturbing the digital board.

ZNA116E

PRINTED CIRCUIT BOARD

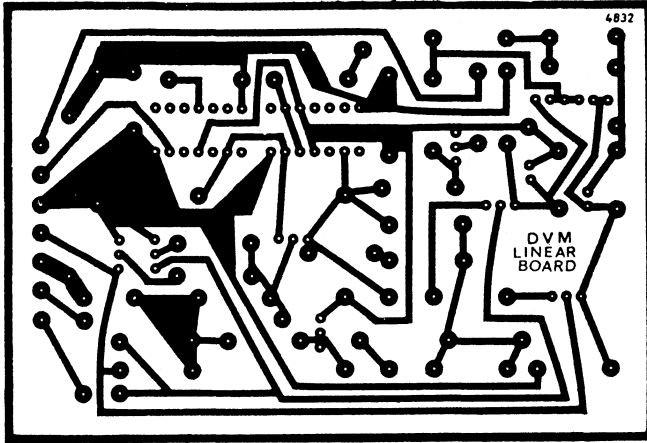

Figure 4. ANALOGUE BOARD (copper side) $\frac{3}{4}$ FULL SIZE

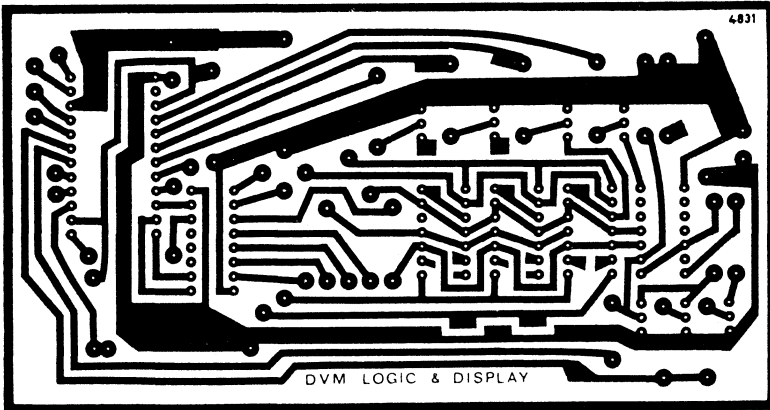
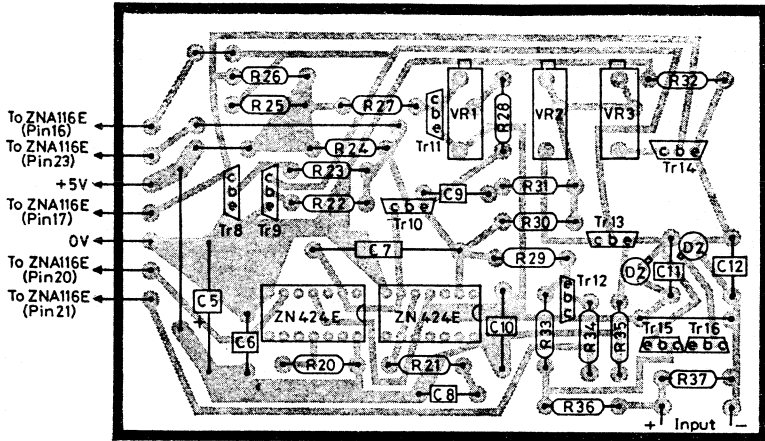

Figure 5. DIGITAL BOARD (copper side) $\frac{3}{4}$ FULL SIZE



4889

ANALOGUE BOARD – Component positions

Figure 6.

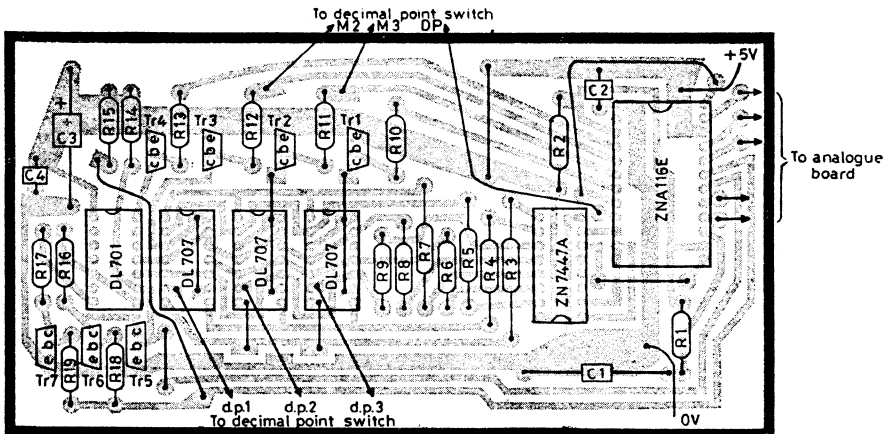

4888

DIGITAL BOARD – Component positions

Figure 7.

ZNA116E

CIRCUIT DIAGRAM OF ANALOGUE BOARD

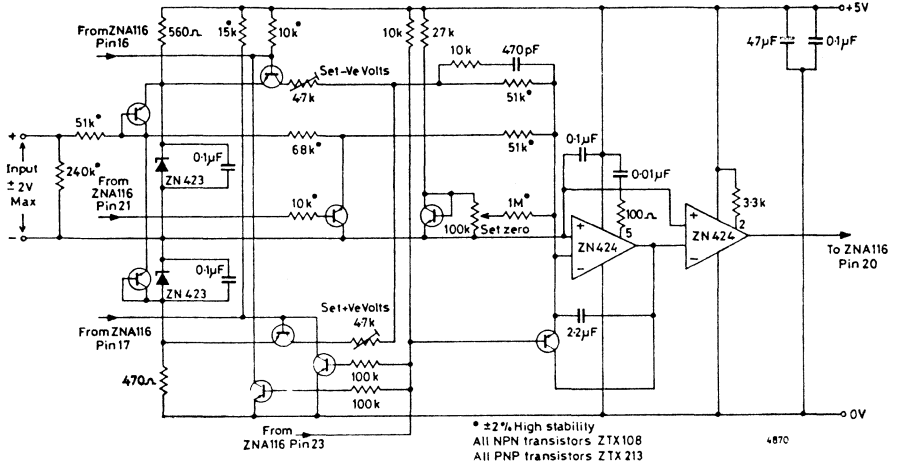

Figure 8.

CIRCUIT DIAGRAM OF DIGITAL BOARD

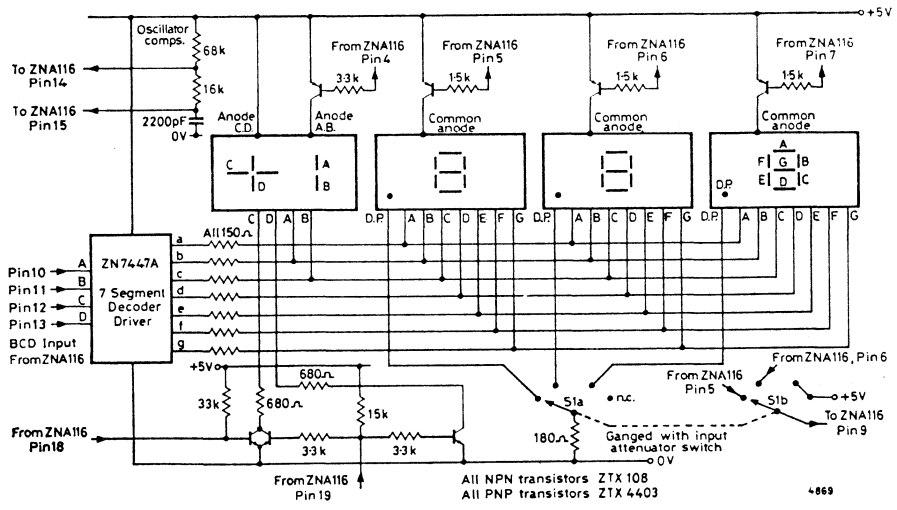

Figure 9.

D.V.M. COMPONENT LIST

R1	16k $\pm 2\%$	R14	33k	R27	27k
R2	68k $\pm 2\%$	R15	15k	R28	1M $\pm 2\%$
R3	150	R16	680	R29	51k $\pm 2\%$
R4	150	R17	680	R30	51k $\pm 2\%$
R5	150	R18	3.3k	R31	10k
R6	150	R19	3.3k	R32	470
R7	150	R20	3.3k	R33	68k $\pm 2\%$
R8	150	R21	100	R34	10k $\pm 2\%$
R9	150	R22	100k	R35	560
R10	1.5k	R23	100k	R36	51k $\pm 2\%$
R11	1.5k	R24	10k	R37	240k $\pm 2\%$
R12	1.5k	R25	10k	R38	180
R13	3.3k	R26	15k		

VR1 100k }
 VR2 5k } Bourns 3009P
 VR3 5k }

All values given in ohms.

All resistors $\pm 10\%$ unless stated otherwise.

C1	2200 pF $\pm 2.5\%$
C2	0.033 μ F
C3	68 μ F 10 vw. electrolytic $\pm 50\%$
C4	0.033 μ F
C5	68 μ F 10 vw. electrolytic $\pm 50\%$
C6	0.1 μ F
C7	2.2 μ F $\pm 10\%$
C8	0.01 μ F
C9	470 pF
C10	0.1 μ F
C11	0.1 μ F
C11	0.1 μ F
C12	0.1 μ F

All capacitors $\pm 20\%$ non-electrolytic unless stated otherwise.

Tr1, Tr2, Tr3 Tr4	} all ZTX4403
Tr5, Tr6, Tr7, Tr8, Tr9,	
Tr10, Tr11, Tr13 Tr14,	} all ZTX 108
Tr15, Tr16,	
Tr12	ZTX213

D1, D2 both ZN423

ZNA116E 1 off
 ZN424E 2 off
 ZN7447A 1 off

DL707L display 3 off
 DL701 display 1 off

ZNA116E

ATTENUATION OF INPUT VOLTAGE

For measuring voltages of ± 2 volts or more, the following input attenuator circuit may be used.

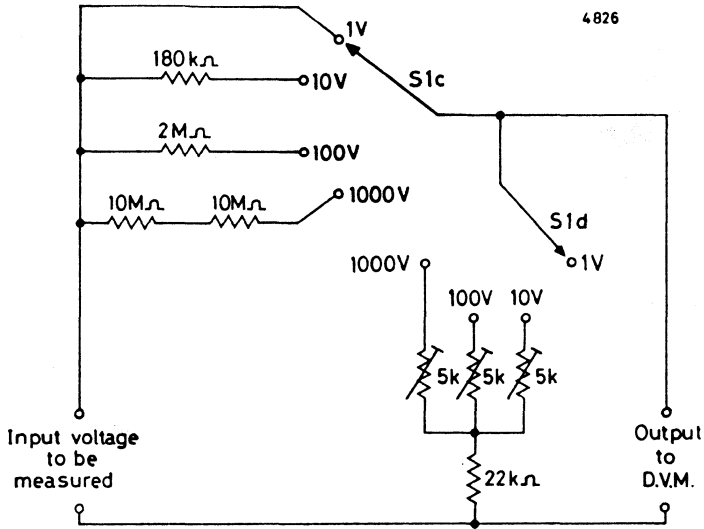

All resistors $\pm 2\%$ high stability, presets $\pm 20\%$ carbon.

Figure 10.

The input impedance is $100\text{ k}\Omega$ on the 1 volt range and $20\text{ k}\Omega/\text{volt}$ on the other three ranges. If a greater impedance than this is required, an attenuator using higher value resistors followed by an F.E.T. input buffer amplifier should be used.

Note: In the above diagram, switches S1c and S1d are ganged with S1a and S1b, the decimal point switch, shown in figure 9.

CONSTRUCTIONAL NOTES

- (1) The leads joining the analogue board to the digital board should not be longer than about six inches.
- (2) Before connecting the circuit to a power supply, make sure that all the external links, shown in figures 6 and 7, have been connected to the printed circuit boards. There should be five links on the analogue board and twelve on the digital board.
- (3) If the applied input voltage is too large, the display will be blanked off as an overload indication. If a diode is connected between pins 8, 24 and 21 of the ZNA116E, as shown below in figure 11, the display will flash for overload conditions.

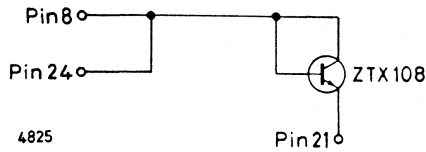

Figure 11.

CALIBRATION PROCEDURE

The range switch is placed in the 1 volt position and the input terminals are shorted together. VR2 and VR3 should be set about half-way. The set-zero preset VR1 is now adjusted until the display just flickers between +0 and -0.

A known positive voltage, between one and two volts, is now connected to the input terminals and VR3 is adjusted until this voltage is displayed.

The input voltage is then reversed and VR2 is adjusted until the display is again correct.

VR1, VR2 and VR3 are now correctly set and should not need altering again.

Since the three 5k presets in the attenuator section are completely independent of each other, these can be easily set to give the required attenuation of 10, 100 and 1000.

Calibration is now complete.

SPECIFICATION OF D.V.M.

Maximum reading	± 1999
Readings per second	$2\frac{1}{2}$ typical
Typical accuracy (1 volt range)	0.1% of reading ± 1 mV
Temperature coefficient (1 volt range)	± 0.1 mV per $^{\circ}\text{C}$ typical
Input impedance	100 k Ω for 1 volt range 200 k Ω for 10 volt range 2 M Ω for 100 volt range 20 M Ω for 1000 volt range
Total supply current (with all segments on)	200 mA typical

ZNA116E

PIN CONNECTIONS

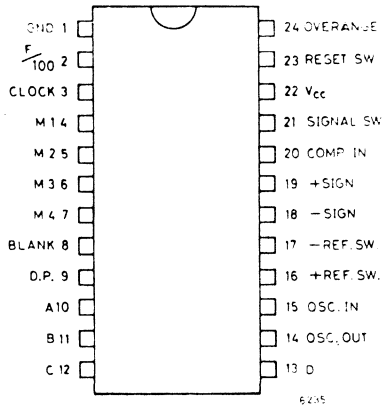

CHIP DIMENSIONS AND LAYOUT

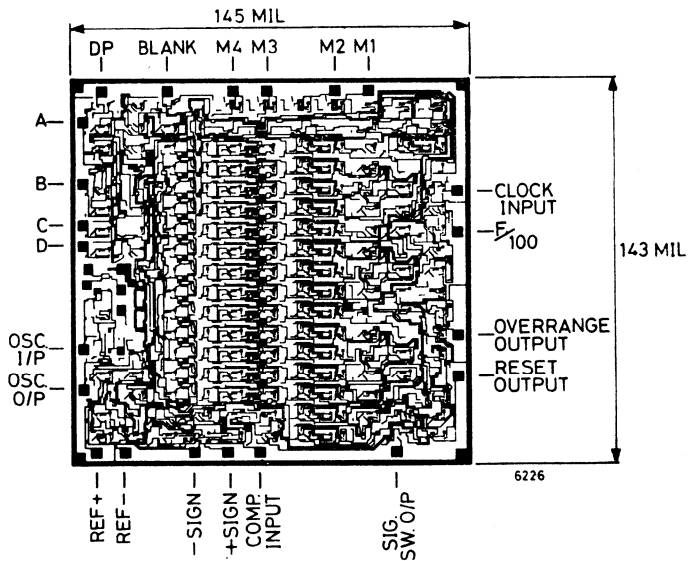



Low Power 3½ Digit D.V.M. Integrated Circuit

FEATURES

- 3½ digit display (± 3999 max. reading)
- Automatic zero adjustment with $1 \mu\text{V}/^\circ\text{C}$ temperature coefficient
- Seven-segment outputs for direct drive of LED displays
- BCD outputs
- Automatic polarity detection and indication
- Flashing overload indication, separate overload output
- Blanking input, e.g. for low battery indication
- Automatic blanking of display leading zeroes
- On-chip clock, may be externally synchronised
- TTL and CMOS compatible
- Single +5V supply
- Pinning optimised for easy p.c.b. layout

DESCRIPTION

The ZNA216 D.V.M. I.C. is a versatile D.V.M. system component which contains all the control logic necessary to construct a dual-slope digital voltmeter, whilst leaving the designer free to configure the analogue circuitry to his own requirements.

The I.C. has multiplexed data outputs, both in BCD format and in seven-segment format for direct drive of LED displays. A number of useful features are incorporated into the device, including leading zero blanking of the display, flashing over range indication and an auto zero facility which removes the need for manual zero adjustment.

Apart from the more obvious applications of D.V.M. and D.P.M. the I.C. can be used to construct any other instrument where an analogue input from, say, a transducer is to be converted into a digital reading, for example a digital thermometer. The ZNA216 may also be used as an A-D converter in single-channel data acquisition systems, or to interface to a microprocessor system.

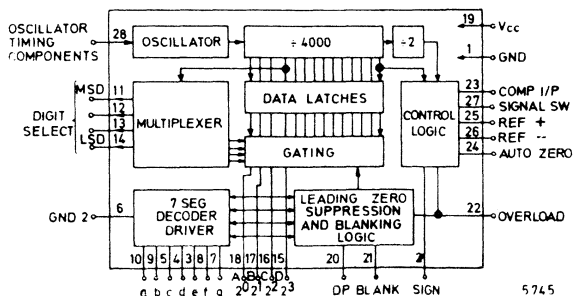

System Diagram

ZNA216E/J

PINNING AND FUNCTIONAL DETAILS

Pin number	Name	Function
1	Gnd 1	Supply 0 volts
2	Sign	Open collector output, goes low when –ve input voltage is being measured.
3	e	Open collector segment output, goes low when segment is on.
4	d	Segment output as above.
5	c	Segment output as above
6	Gnd 2	0 volt supply for segment drivers, must be connected to Pin 1.
7	g	Segment output as above
8	f	Segment output as above
9	b	Segment output as above.
10	a	Segment output as above
11	M1	Digit drive output, goes low for the most significant digit to be displayed, first in digit scan sequence.
12	M2	Digit drive output, goes low for the second most significant digit to be displayed, second in digit scan sequence.
13	M3	Digit drive output, goes low for the third most significant digit to be displayed, third in digit scan sequence.
14	M4	Digit drive output, goes low for the least significant digit to be displayed, fourth in digit scan sequence.
15	D	2 ³ BCD data output.
16	C	2 ² BCD data output.
17	B	2 ¹ BCD data output.
18	A	2 ⁰ BCD data output.
19	V _{CC}	Supply +5 volts.
20	DP	When this input is at logic 1, leading zeroes are blanked.
21	Blank	While this input is at logic 1, all segment outputs are off and all BCD data outputs are at logic 1.
22	Overload	If the integrator capacitor does not discharge before the counter reaches 4000, this output goes to logic 1.
23	Comp.	This input is connected to the output of the external comparator.
24	Azero	When this output is high, auto zero correction is applied to the integrator.

ZNA216E/J

Pin number	Name	Function
25	Ref+	When this output is at logic 1, the +ve reference voltage is connected to the integrator.
26	Ref-	When this output is at logic 1, -ve reference voltage is connected to the integrator.
27	Signal switch	When this output is at logic 1, the input voltage to be measured is connected into the integrator.
28	Clock	The external clock oscillator components are connected to this pin (see diagrams). Alternatively, this pin may be driven by an external signal. A measurement is made every 8000 clock periods. The counter toggles on -ve going clock edges and transfer to the latches occurs at the first +ve going clock edge after comparison has been made which avoids false triggering from the integrator output. Max. clock frequency 50 kHz.

ZNA216E/J

(a) *Absolute Maximum Ratings:*

Supply voltage	7.0 volts
Operating temperature	0°C to +70°C
Storage temperature	-55°C to +125°C

(b) *Electrical Characteristics ($T_A = 0^\circ\text{C}$ to $+70^\circ\text{C}$, $V_{CC} = 5.0\text{V}$ unless otherwise specified).*

Parameter		Min.	Typ.	Max.	Unit	Test conditions
Supply voltage		4.5		5.5	V	
Supply current				20	mA	
Low level input voltage	All inputs			0.8	V	
Low level input current	All inputs			-4	μA	$V_{in} = 0\text{V}$
Input clamp diode voltage	All inputs			-1.5 V_{CC} +1.5	V V	$I_{in} = -12\text{ mA}$ $I_{in} = 10\text{ mA}$
High level input voltage	Oscillator RC input	2.5			V	
	All other inputs	2.0			V	
High level input current	Oscillator RC input			100	μA	$V_{in} = 2.5\text{V}$
	All other inputs			4	μA	$V_{in} = 5.0\text{V}$
Low level output voltage	a, b, c, d, e, f, g			0.8	V	$I_{sink} = 20\text{ mA}$
	Sign			0.4	V	$I_{sink} = 5\text{ mA}$
	Overload, Ref+, Ref-, Azero, Signal switch, a,b,c,d,M1,M2, M3, M4			0.4	V	$I_{sink} = 1.6\text{ mA}$
High level output voltage	Overload, Ref+, Ref-, Azero, Signal switch, a,b,c,d,M1,M2, M3, M4	2.4			V	$I_{out} = 10\ \mu\text{A}$
			V_{CC} -0.1		V	$I_{out} = 0$
High level output current	a,b,c,d,e,f,g Sign			-10	μA	$V_{out} = 5.0\text{V}$

(c) *Note:*

Although the oscillator and logic will function up to 50 kHz, this is not recommended as the analogue circuitry becomes more critical.

THE DUAL SLOPE SYSTEM

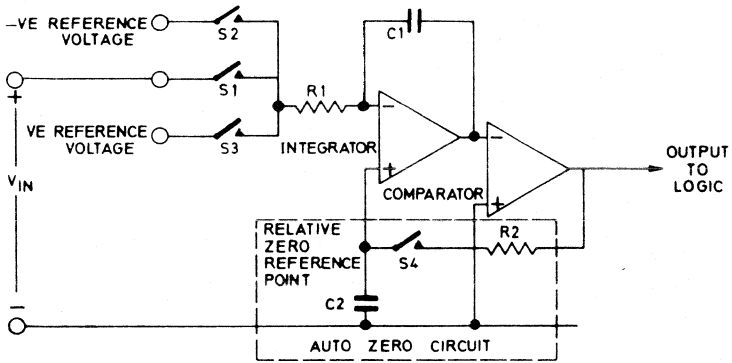

5746

Figure 1. Dual Slope Block Diagram.

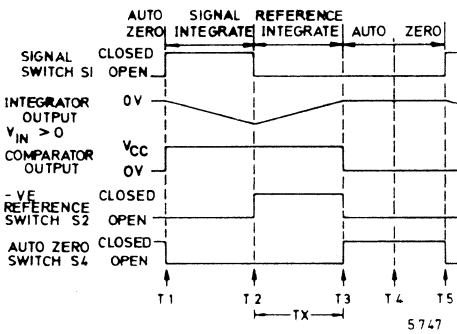

5747

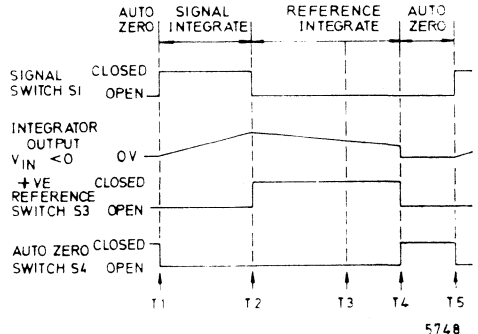

5748

Figure 2a. Timing Diagram for in-range input.

Figure 2b. Timing diagram for overrange input

ZNA216E/J

Dual slope integration is a D.V.M. circuit technique designed to cancel out the effects of drift in circuit components. A block diagram of the analogue section of a dual-slope D.V.M. is shown in figure 1, whilst a timing diagram for its operation is shown in figure 2.

At time T_1 , S1 is closed by the D.V.M. logic, connecting the input signal to the integrator until time T_2 , which is 2000 clock periods after T_1 . During this time the integrator output ramps positive or negative, depending on input voltage polarity, to a voltage

$$V_o = \frac{-V_{in} 2000 t_c}{R_1 C_1}$$

where t_c is the clock period.

The polarity of the integrator output voltage during this period, and hence of the input voltage, is sensed by the comparator, whose output is connected to the control logic.

At time T_2 , S1 is opened and, depending on the input voltage polarity, either S2 or S3 is closed. This connects a reference voltage of opposite polarity to V_{in} to the integrator input, so that the integrator output ramps back towards zero. The number of clock periods required for the integrator output to reach zero is counted by the DVM counter. When the output reaches zero the comparator output changes state, S2 or S3 opens and the count is stopped. Since the second integration also takes place over a voltage V_o then,

$$V_o = \frac{-V_{REF} n t_c}{R_1 C_1} \text{ where } n \text{ is the count at time } T_3$$

but V_o also equals $\frac{-V_{in} 2000 t_c}{R_1 C_1}$

$$\text{thus } n = \frac{2000 V_{in}}{V_{REF}}$$

R_1 , C_1 and t_c have disappeared from this final equation, so the accuracy of the D.V.M. is unaffected by the long-term stability of these parameters. The only factors influencing accuracy are the stability of V_{REF} and variations in the 'on' resistance of the analogue switches S1 to S3. The former can be assured by careful choice of a reference source, e.g. the Ferranti ZN423 or ZN458, whilst the effect of the latter can be minimised by making R_1 large compared to the on resistance of S1 to S3.

If V_{REF} is exactly 2V then $n = 1000 V_{in}$, i.e. the count will be equal to the input voltage in millivolts. For the ZNA216 the maximum reading is 3999. If a count of 4000 occurs before the integrator output reaches zero, as shown in figure 2b, then S2 or S3 will open and the overrange output will go high.

In a practical D.V.M. it is unlikely that a reference voltage of exactly 2V will be available, or an input range other than 3.999V may be required. In this case a different resistor value (R_{REF}) will be used for the reference integration. The equation then becomes :

$$n = \frac{2000 V_{in} \cdot R_{REF}}{V_{REF} \cdot R_1}$$

R_1 and R_{REF} should be high-stability types.

AUTO ZERO

Any offset voltage and bias current in the integrator will be integrated along with the input signal and since, for example, a 3.999V D.V.M. has a resolution of 1 mV an offset of a few hundred microvolts can lead to errors in the least significant digit. Manual zero adjustment is time-consuming and has to be repeated frequently due to temperature drift.

The auto zero of the ZNA216 operates during the period T_3 to T_5 , or T_4 to T_5 in the case of an overrange input. S4 is closed, S1 S2 and S3 are opened so that only the integrator offset voltage is integrated, thus causing the integrator output to drift either positive or negative. The integrator output is amplified by the comparator (which is nothing more than an extremely high gain amplifier) and this charges C2 via R2 to apply a voltage to the non-inverting input of the integrator. The polarity of this voltage is such as to null out the effects of integrator offset voltage and bias current and thus cancel integrator drift. Depending on comparator gain a zero error of a few hundred nanovolts may be achieved by this method.

HUM REJECTION

Any mains hum pickup superimposed on the input signal will cause errors in the D.V.M. reading. However, if the period $T_2 - T_1$ is made a multiple of the mains period then equal numbers of positive and negative half-cycles of the mains waveform will be integrated and will cancel each other out. For 50 Hz mains $T_2 - T_1$ should be 20 ms or a multiple thereof, while for 60 Hz mains $T_2 - T_1$ should be 16.67 ms or a multiple thereof.

Adjustment of the period $T_2 - T_1$ is achieved by varying the frequency of the clock oscillator which controls the operation of the D.V.M.

DISPLAY MULTIPLEXING

The BCD and seven-segment data outputs are multiplexed, the data appearing in the sequence MSD to LSD. To identify which digit is present at the outputs at any time the four digit select outputs go low in turn, synchronous with the relevant digit appearing at the data outputs. The seven segment outputs can be used to drive the cathodes of a multiplexed common-anode LED display whilst the digit select outputs may be used to turn on digit-drive transistors, which activate each display digit in sequence.

DECIMAL POINT (ZERO BLANKING) INPUT

Before the start of each multiplex cycle a latch in the I.C. is set. This holds the display blanked until non-zero data appears at the BCD outputs, when the latch is reset and the display is unblanked. For example, if the MSD were non-zero the latch could reset immediately the MSD appeared, so all four digits would be displayed. Conversely if the MSD were zero but the second digit were non-zero then the display would be blanked for the MSD and only three digits would appear. In this way leading zeroes in the display are suppressed. The LSD is always displayed whether zero or not.

The D.P. input can be used to override the zero blanking by taking this pin to logic '0'. This facility allows a correct display to be obtained when a decimal point is used.

For example, if the decimal point is to the left of the MSD then a low-going pulse to the D.P. input synchronous with the MSD output will cause all digits to the right of the decimal point to be displayed, whether zero or not. Thus, if the input voltage were, say .0056 volts then the display would be .0056. If the zero blanking were not overridden in this way the display would be .--56, which is clearly unsatisfactory.

OSCILLATOR CIRCUIT

The operation of the D.V.M. circuit is controlled by a clock oscillator, which provides drive for the counter, control logic and display multiplexing. Two external components, a resistor and a capacitor, are required to make the oscillator function. The oscillator temperature stability is typically $\pm 0.02\%$ per °C.

As mentioned earlier, the oscillator frequency should be chosen so that $T_2 - T_1$ is a multiple of the mains period. It should not be chosen so low as to cause noticeable flicker in the display multiplexing, but on the other hand it should not be chosen too high or the design of the analogue circuitry becomes more critical.

The optimum oscillator frequency is 20 kHz since this makes $T_2 - T_1 = 100$ ms which gives good hum rejection at either 50 Hz or 60 Hz. This frequency can be obtained by using the component values shown in figure 3. The potentiometer may be adjusted to give a frequency of 20 kHz measured at pin 28, in which case a high impedance, low capacitance probe should be used to avoid loading the oscillator. Alternatively, the trimmer may be adjusted to give a frequency of 500 Hz at any of the digit select outputs, when no special precautions are required.

If required the oscillator timing components may be omitted and the oscillator input may be driven by an external clock at TTL logic levels.

ZNA216E/J

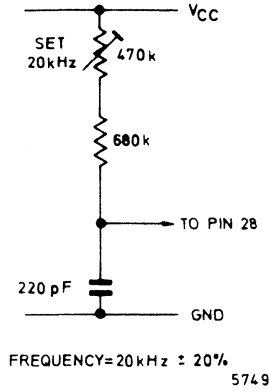

Figure 3. Oscillator external components.

INPUT AND OUTPUT CIRCUITS

Apart from the oscillator input (which is a Schmitt trigger type of circuit) all other inputs are as shown in figure 4a. All outputs are as shown in figure 4b, except for those designated as open-collector, which have no pull-up resistor.

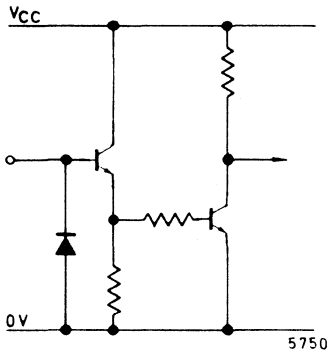

Figure 4a. Input circuit

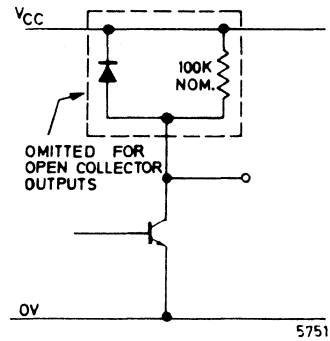
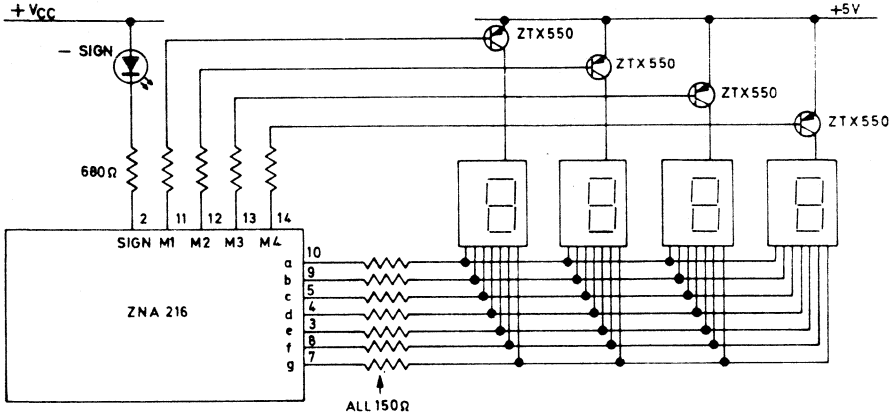

Figure 4b. Output circuit

ZNA216E/J

DISPLAY DRIVING

The 20 mA sink capability of the segment outputs allows common anode LED displays to be driven with a minimum of external components, as shown in figure 5. The segment current limit resistors should be chosen to give the desired segment current, allowing for the forward voltage drop of the LED, whilst the digit output resistors should be chosen to give sufficient base current to saturate the digit drive transistors.



5752

Figure 5. Display drive circuit

OVERRANGE AND LOW BATTERY INDICATION

If the input voltage exceeds the full-scale range then the display will flash all 'eights' and the over-range output, pin 22, will go high. Low battery indication may also be provided by the addition of the simple circuit shown in figure 6.

Whilst the battery voltage is above 4.4V T_1 will be turned on via R1 and R2. Below this voltage the base potential supplied by these resistors will be insufficient to turn on T_1 and it will then be turned on and off cyclically by the auto-zero output, causing the display to flash whatever reading is present.

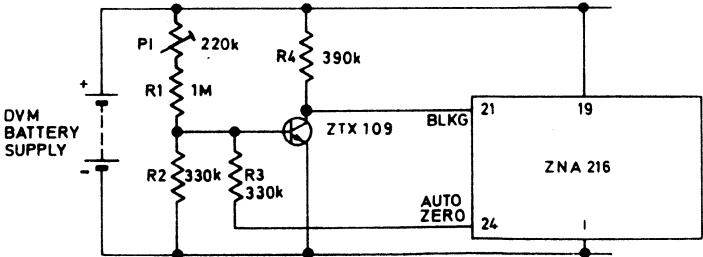

5753

Figure 6. Low battery indication

ZNA216E/J

A PORTABLE D.V.M.

Figure 7 shows the circuit of a battery-powered D.V.M. based on the ZNA216, which uses readily available components. ZN424 op-amps are used for the integrator and comparator, whilst bipolar silicon transistors are used for the analogue switches. The basic sensitivity of the instrument is 4V, and additional ranges of 40V and 400V are provided by means of an input attenuator. Printed circuit board and component layouts for the D.V.M. are given in figures 8a to 9b.

However, this circuit design should by no means be considered as immutable. Since the analogue circuitry is external to the ZNA216 it may be configured to suit the designer's needs to give higher input impedance, increased sensitivity etc.

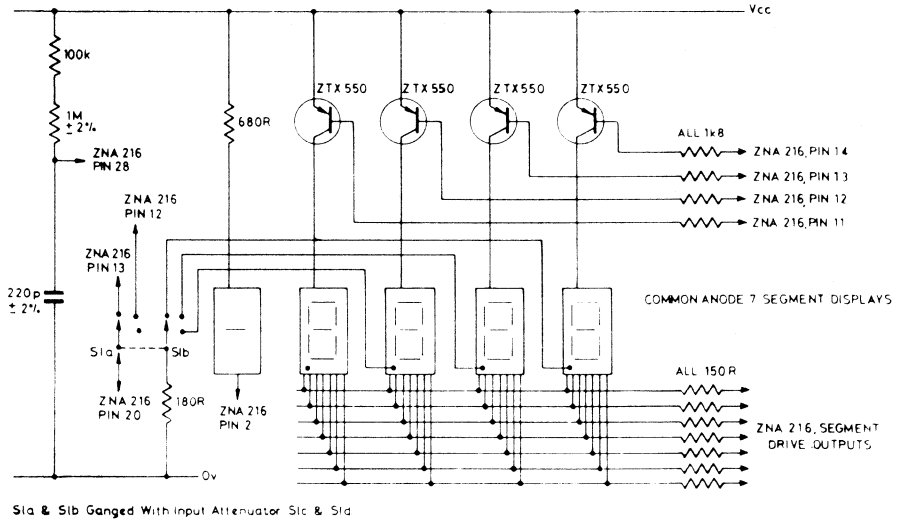

Figure 7a. Battery-powered D.V.M. circuit, display section.

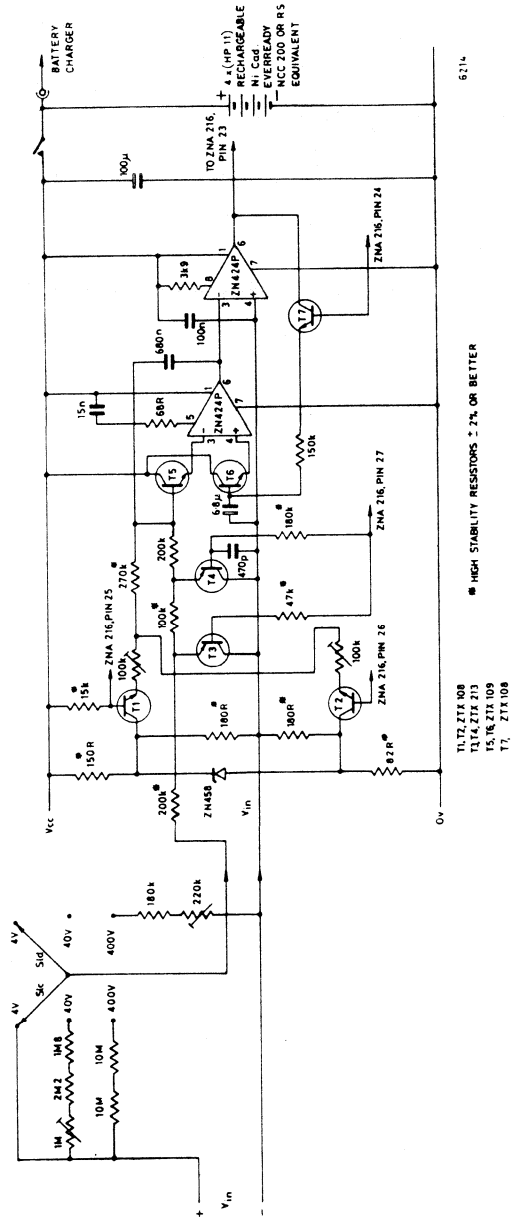
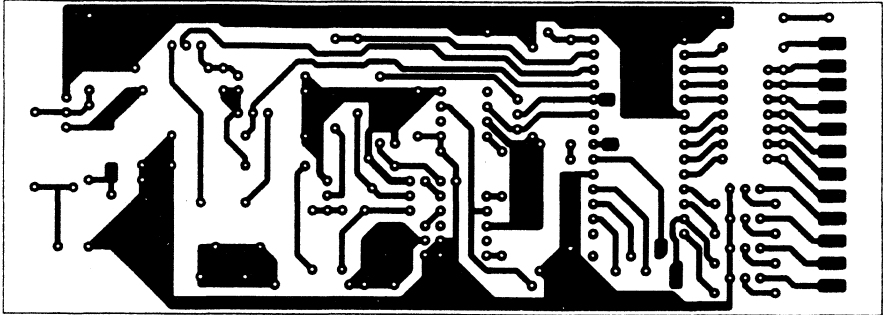

Figure 7b. Battery-powered D.V.M. circuit, analogue section.

ZNA216E/J



62 16

Figure 8a. D.V.M. Main Board

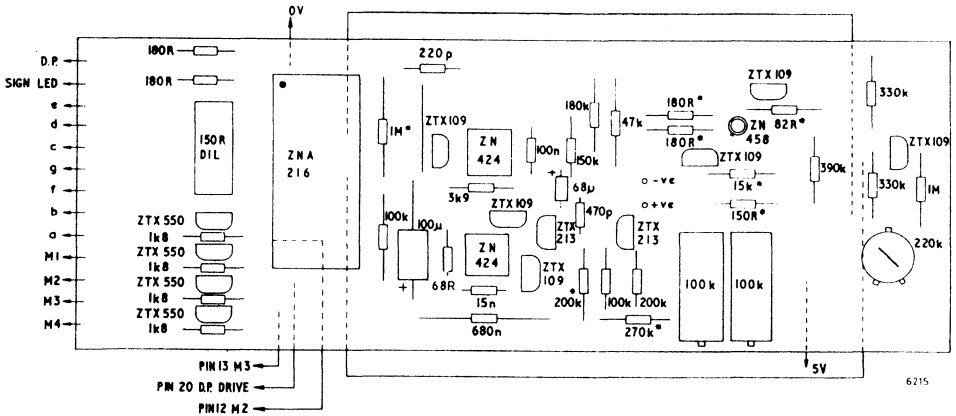

6215

Figure 8b. Component Layout for Figure 8a.

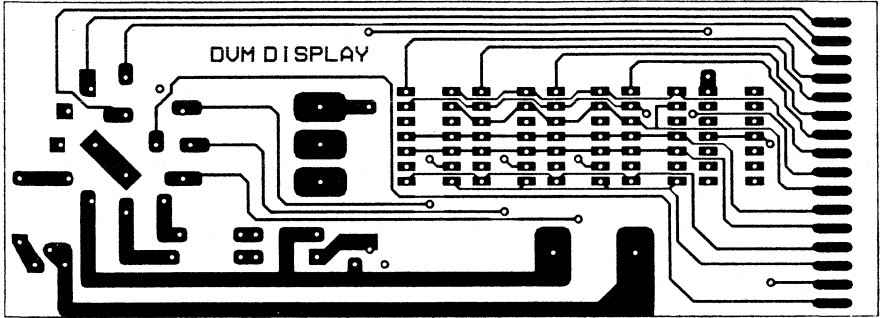

6218

Figure 9a D.V.M. Display Board

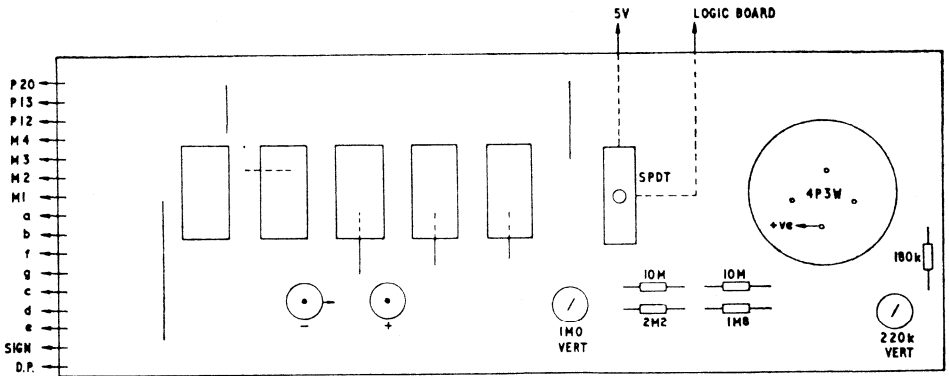

6217

Figure 9b. Component Layout for Figure 9a.

ZNA216E/J

MICROPROCESSOR INTERFACING

The ZNA216 may be used as a dual-slope A to D converter in data loggers and other data acquisition systems, where its $3\frac{1}{2}$ decade range offers a resolution comparable to a 13 bit binary ADC, but in a more convenient BCD format.

Figure 10 is a block diagram which illustrates how the ZNA216 may be interfaced to an 8-bit microprocessor. The principle of operation is that the four multiplexed BCD digits of the ZNA216, plus the sign and overrange bits, are stored in four 4-bit latches so that they are available in parallel form. The contents of the latches can then be read into the microprocessor as two 8-bit words. The latches used are type 74173 which have three-state outputs for direct connection to the μ P data bus. Data is clocked into the latches using the positive-going edge of the appropriate digit drive outputs.

The latches are treated as two memory locations by using an address decoder which is connected to their output enable pins. In this way data can be read out of the latches just as from any other memory locations. Once data is in the latches it may be read out whilst the ZNA216 performs the next measurement, thus eliminating any waiting time. The only time when data cannot be read out of the latches is just after the ZNA216 has completed a measurement. At this time the data in the internal latches of the ZNA216 will have been updated and the data in the 74173s may thus be changing. The data in the latches will be stable after two multiplexed cycles of the ZNA216, which is 4 ms if a 20 kHz clock is used.

Since the auto-zero output of the ZNA216 goes high when a measurement has been completed this output may be used as a BUSY signal. Data should not be read from the 74173 latches until at least 4 ms after the auto-zero output has gone high.

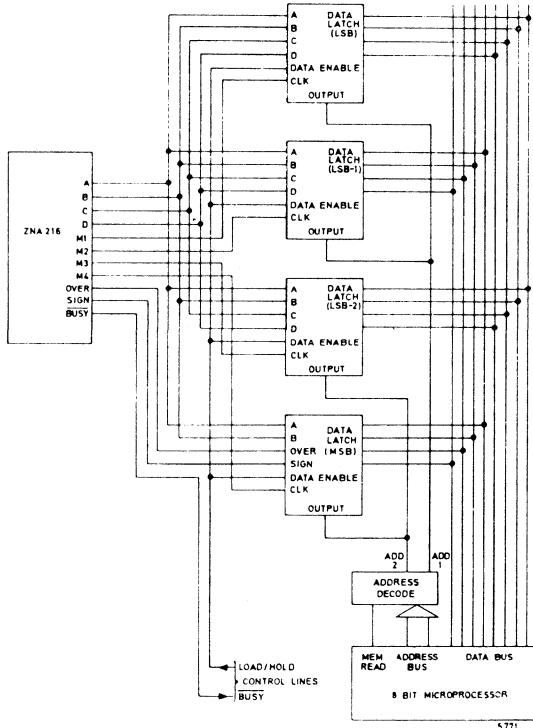
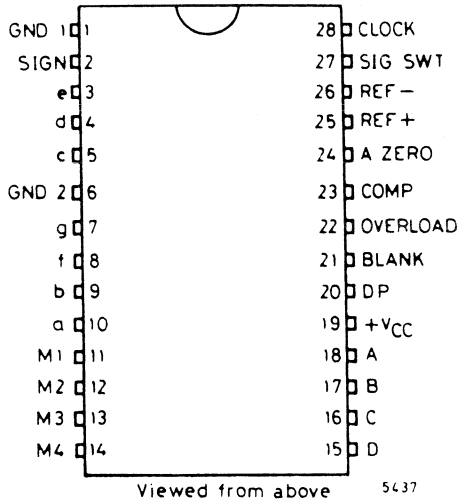

Figure 10. Interfacing the ZNA216 to a Microprocessor

ZNA216E/J

PIN CONNECTIONS



CHIP DIMENSIONS AND LAYOUT

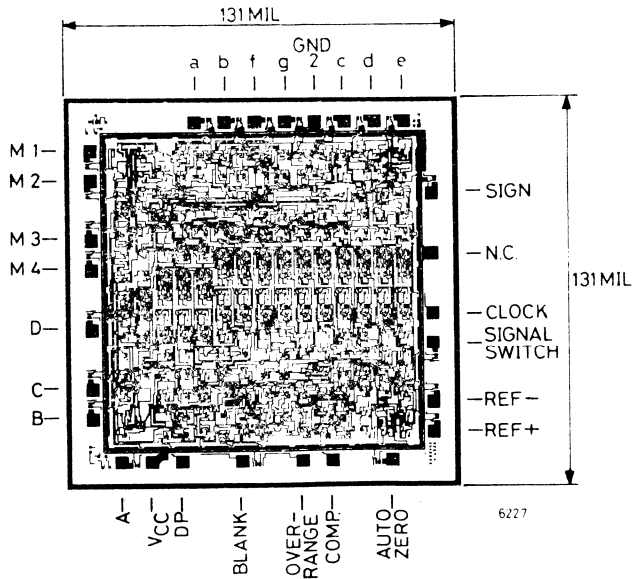

3. Precision Voltage References

Contents

	page
Selection Guide	3-3
ZN 404	3-5
ZN 423	3-9
ZN 458	3-17
ZN 458 A	3-17
ZN 458 B	3-17
ZN REF SERIES	3-21
ZN REF 025	3-25
ZN REF 040	3-29
ZN REF 050	3-33
ZN REF 100	3-37

PRODUCT SELECTION GUIDE PRECISION VOLTAGE REFERENCES

TYPE	REFERENCE VOLTAGE (V)	TEMPERATURE COEFFICIENT (ppm)	REFERENCE CURRENT (mA)	OPERATING TEMPERATURE RANGE (°C)	TRIMMABLE ± 3 OR ± 5 %	FEATURES	PAGE
ZN404	2,45	146	2-120	0 to 70	-	Very low cost	3-5
ZN423	1,26	30	1,5-12	0 to 70	-	Low R.M.S. noise voltage	3-9
ZN458	2,45	100	2-120	0 to 70	-	No shaping capacitor required	3-17
ZN458 A	2,45	50	2-120	0 to 70	-	No shaping capacitor required	3-17
ZN458 B	2,45	30	2-120	0 to 70	-	No shaping capacitor required	3-17
ZN REF 025 A SERIES	2,49	50	0,15-10	-55 to +125	+	Available in 3 initial tolerances, 1, 2 and 3% ZN REF SERIES parts are mask-programmable between 2.5 and 10 V	3-25
ZN REF 025 B SERIES	2,49	30	0,15-10	-20 to +85	+		3-25
ZN REF 025 C SERIES	2,49	25	0,15-10	0 to 70	+		3-25
ZN REF 040 A SERIES	4,01	01	0,15-10	-55 to +125	+		3-29
ZN REF 040 B SERIES	4,01	30	0,15-10	-20 to +85	+		3-29
ZN REF 040 C SERIES	4,01	25	0,15-10	0 to 70	+		3-29
ZN REF 050 A SERIES	4,98	50	0,15-10	-55 to +125	+		3-33
ZN REF 050 B SERIES	4,98	30	0,15-10	-20 to +85	+		3-33
ZN REF 050 C SERIES	4,98	25	0,15-10	0 to 70	+		3-33
ZN REF 100 A SERIES	9,96	50	0,15-50	-55 to +125	+		3-37
ZN REF 100 B SERIES	9,96	30	0,15-50	-20 to +85	+	3-37	
ZN REF 100 C SERIES	9,96	25	0,15-50	-0 to 70	+	3-37	



2.45 Volt Precision Reference Regulator

FEATURES

- Low temperature coefficient
- Low slope resistance
- Very good long term stability
- Low noise
- Internally shaped
- Tight tolerance
- Two pin package

DESCRIPTION

The ZN404 is a monolithic integrated circuit providing a precise stable regulator source of 2.45 volts in a two lead package without the need for an external shaping capacitor.

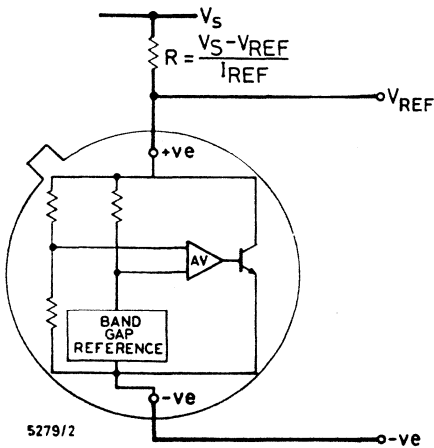

Circuit diagram

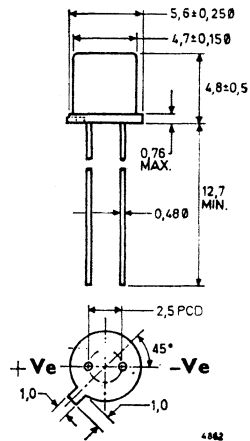

Lead Configuration
Dimensions in millimetres

ZN404

MAXIMUM RATINGS

Dissipation	300 mW
Operating Temperature Range	0 to + 70°C
Storage Temperature Range	-55 to +150°C

ELECTRICAL CHARACTERISTICS (at 25°C ambient temperature unless otherwise stated).

Parameter	Symbol	Min.	Typ.	Max.	Unit	Test Conditions
Output Voltage	V_{REF}	2.38	2.45	2.52	V	Measured at 2 mA
Slope Resistance	R_{REF}	—	0.2	0.4	Ω	
Reference Current	I_{REF}	2	—	120	mA	
Maximum Change in V_{REF}	ΔV_{REF}	—	6	25	mV	0 to +70°C

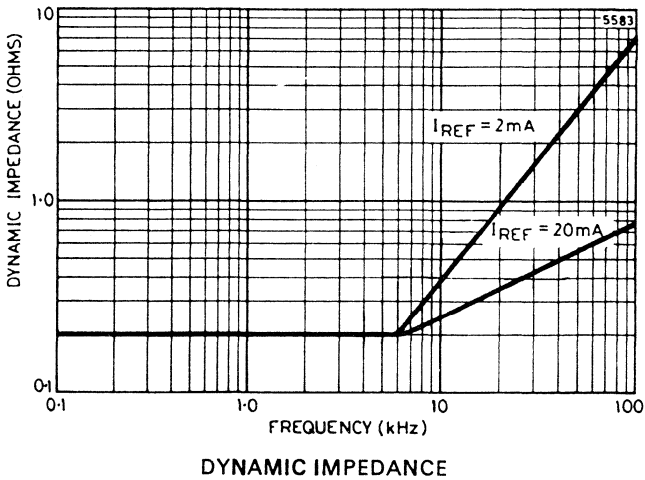

FORWARD CHARACTERISTIC (Typical)

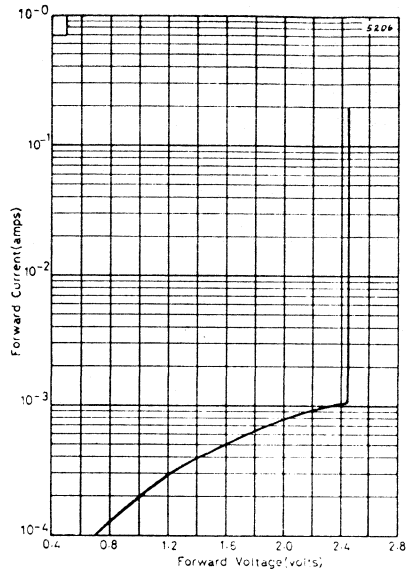

TEMPERATURE CHARACTERISTIC (Typical)

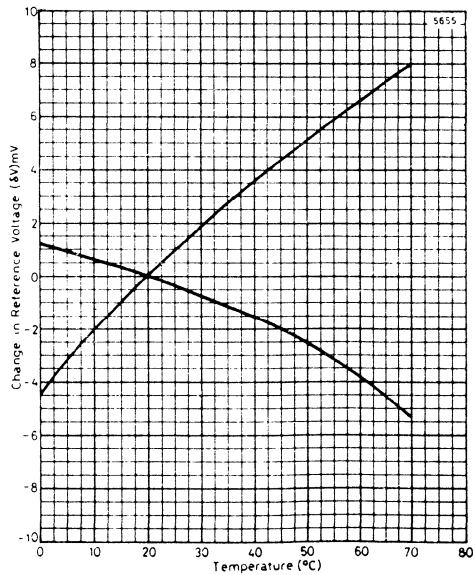

ZN404

DERATING CURVE

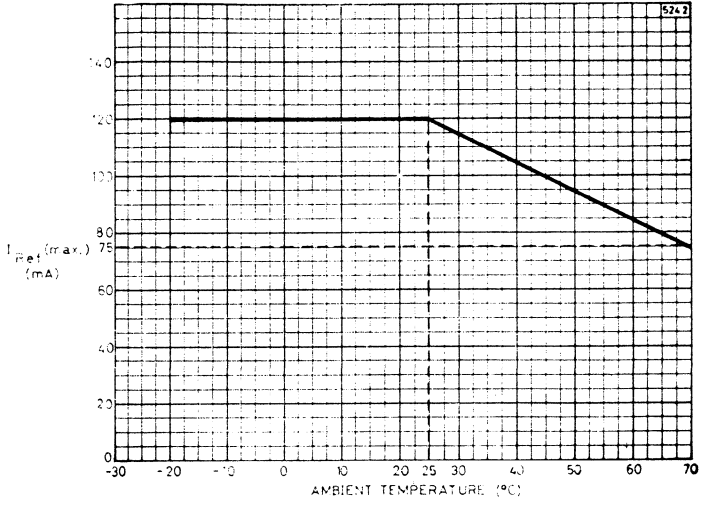

1.26 Volt Precision Voltage Reference Source

FEATURES

- Low voltage
- Low temperature coefficient
- Very good long term stability
- Low slope resistance
- Low RMS noise
- Tight tolerance
- High power supply rejection ratio
- Two pin package

DESCRIPTION

The ZN423 is a monolithic integrated circuit utilising the energy band gap voltage of a base-emitter junction to produce a precise, stable, reference source of 1.26 volts. This is derived via an external dropping resistor for supply voltages of 1.5 volts upwards. The temperature coefficient of the ZN423, unlike conventional Zener diodes, remains constant with reference current. The noise figure associated with breakdown mechanisms is also considerably reduced.

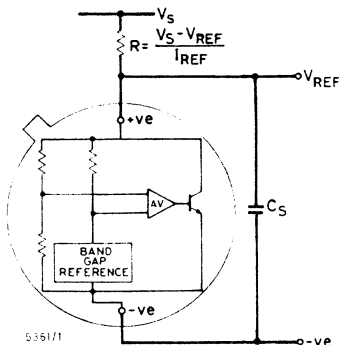

Circuit diagram

PACKAGE OUTLINE

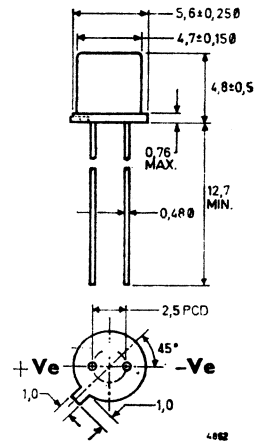

2 LEAD TO-18

Pinning configuration

Dimensions in millimetres

ZN423

ABSOLUTE MAXIMUM RATINGS

Reference current I_{REF}	20 mA
Operating temperature range	0°C to +70°C -55°C to +125°C
Storage temperature range	-65°C to +165°C

ELECTRICAL CHARACTERISTICS (at ambient temperature of 25°C unless otherwise stated).

Parameter	Symbol	Min.	Typ.	Max.	Unit	Note
Output voltage	V_{REF}	1.2	1.26	1.32	V	
Slope resistance	R_{REF}	—	0.5	1.0	Ω	1
Reference current	I_{REF}	1.5	—	12	mA	
Temperature coefficient		—	30	—	ppm/°C	
Shaping capacitance	C_S	0.1	—	—	μF	
External resistance	R_{EXT}	100	—	—	Ω	2
R.M.S. noise voltage 1 Hz to 10 kHz		—	6	—	μV	
Power supply rejection ratio $V_{REF} = 1.26V$ $I_{REF} = 2.5mA$ $V_{CC} = 5.0V$	PSRR	—	60	—	dB	3
V_{REF} drift at 125°C	σV_{REF}	—	10 100	—		ppm/1000 hours ppm/year

Note 1 $I_{REF} = 5 \text{ mA}$

Note 2 $R_{EXT} = (V_{CC} - V_{REF})/I_{REF}$

Note 3 $PSRR = R_{EXT}/R_{REF}$

DERATING CURVE

Reference current I_{REF} (max.) vs Operating temperature.

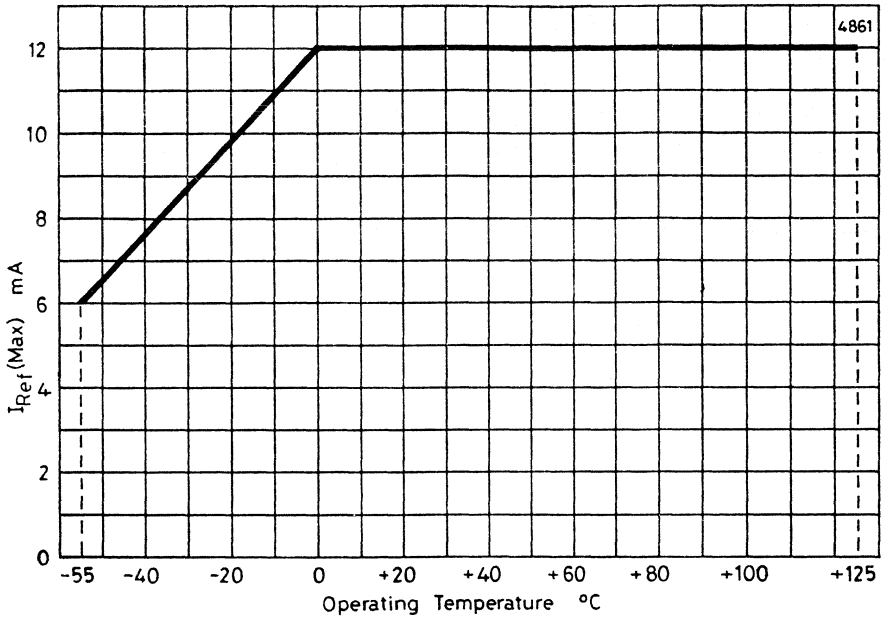

Slope resistance vs Frequency ($I_{REF} = 5 \text{ mA}$).

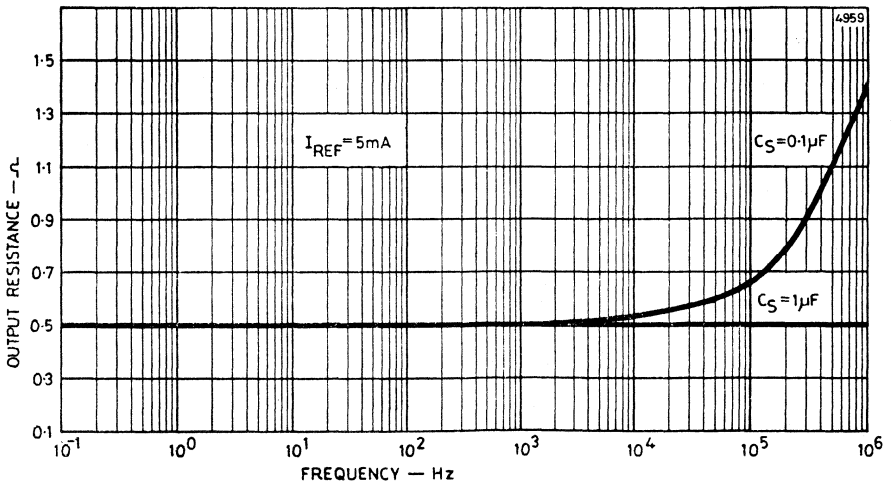

ZN423

APPLICATIONS

1. 5 Volt, 0.5 Amp Power Supply.

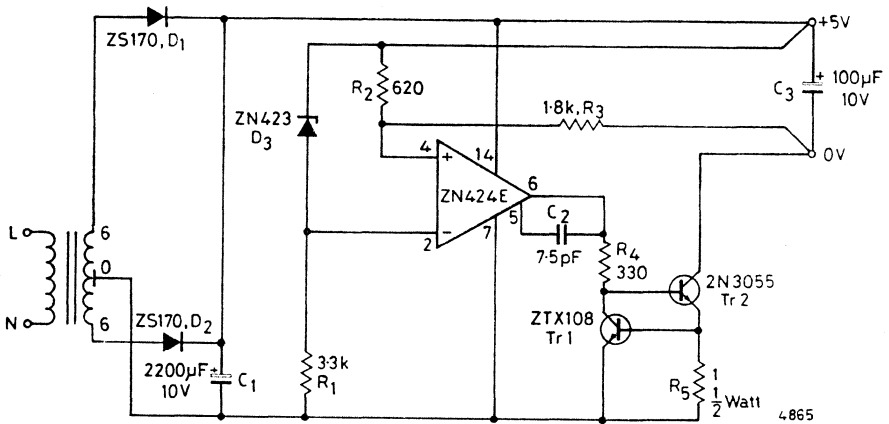

Figure 1.

This circuit is essentially a constant current source modified by the feedback components R₂ and R₃ to give a constant voltage output.

The output of the ZN424E need only be 2 volts above the negative rail, by placing the load in the collector of the output transistor Tr₂. Current circuit is achieved by Tr₁ and R₅. This simple circuit has the following performance characteristics:

- Output noise and ripple (Full load) = 1 mV r.m.s.
- Load regulation (0 to 0.5A) = 0.1%.
- Temperature coefficient = ±100 ppm/°C.
- Current limit = 0.65A.

2. 5 Volt, 1.0 Amp Power supply.

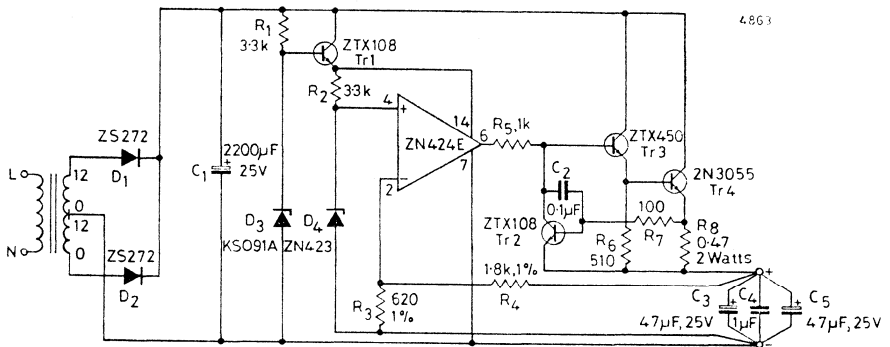

Figure 2.

The circuit detailed in Figure 2 provides improved performance over that in Figure 1. This is achieved by feeding the ZN423 reference and the ZN424E error amplifier from a more stable source, derived from the emitter-follower stage (Tr₁). The supply rejection ratio is improved by the factor R_1/R_S , where R_S is the slope resistance of D₃. The output voltage is given by: $\frac{(R_3 + R_4)}{R_3} \cdot V_{REF}$ and may be adjusted by replacing R_3 with a 220Ω and a 500Ω preset potentiometer.

The output is protected against short circuits by Tr₂ setting a current limit of 1.6A.

ZN423

3. 0 to 12 Volt, 1 Amp Power Supply.

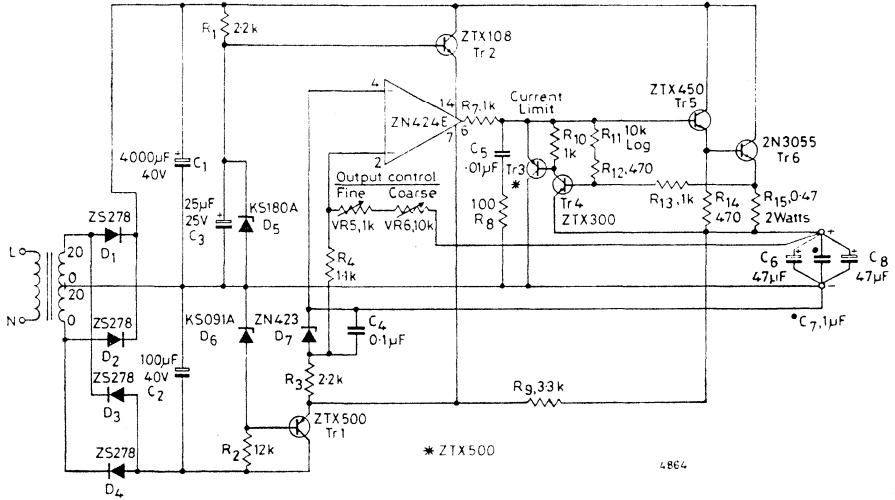

Figure 3.

The above circuit provides a continuously variable, highly stable voltage for load currents up to 1A.

The output voltage is given by:
$$V_O = \frac{(V_{R5} + V_{R6})}{R_4} V_{REF}$$

and is controlled by V_{R5} and V_{R6} which should be high quality components (preferably wire wound).

The emitter follower stages Tr_1 and Tr_2 buffer the bias and reference from the output stage. The negative rail allows the output to operate down to 0 volts.

The current limit stage monitors output current through R_{15} . As the potential across R_{15} increases due to load current, Tr_4 conducts and supplies base current for Tr_3 , thus diverting part of the output from the ZN424E, via Tr_3 to Tr_5 .

Shaping is achieved by the network C_5 , R_8 together with the output decoupling capacitors which also maintain low output resistance at frequencies above 100 kHz.

The power supply has the following performance characteristics:

- Output noise and ripple (Full load) < 100 μ V r.m.s.
- Output resistance (0 to 1 Amp) 1 m Ω
- Temperature coefficient \pm 100 ppm/ $^{\circ}$ C

4. Variable Current Source, 100 mA to 2 Amps.

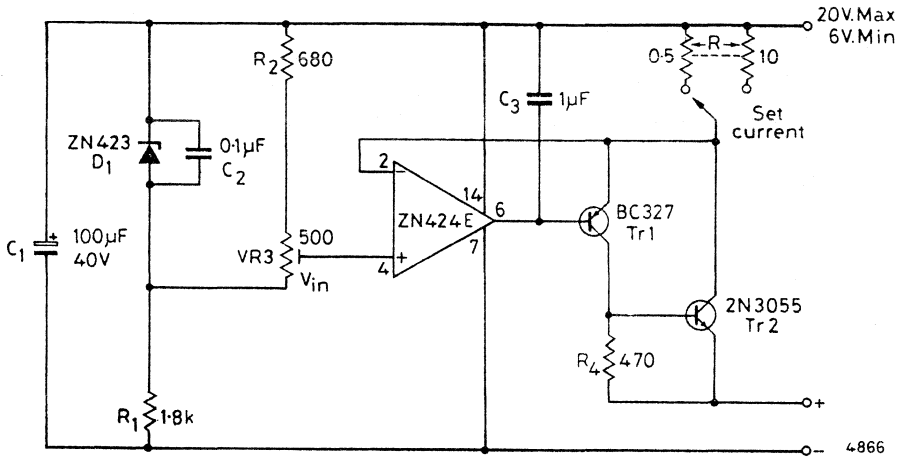

Figure 4.

In this circuit the output current is set by the resistor R in the collector of Tr₂, which may be switched to offer a range of output currents from 100 mA to 2A with fine control by means of VR₃ which varies the reference voltage to the non-inverting input of the ZN424E.

The feedback path from the output to the inverting input of the ZN424E maintains a constant voltage across R, equal to $(V_{CC} - V_{in})$ and hence a constant current to the load given by $(V_{CC} - V_{in})/R$.



2.45 Volt Precision Reference Regulator

FEATURES

- Guaranteed 5 mV maximum deviation over full temperature range
- Low temperature coefficient 0.003%/°C
- Low slope resistance - 0.1Ω
- Very good long term stability - 10 ppm
- Low noise - 10 μV
- Internally shaped
- Tight tolerance ±1.43%
- Two pin package
- Wide operating current 2 - 120 mA

DESCRIPTION

The ZN458 is a monolithic integrated circuit providing a precise stable reference source of 2.45 volts in a two lead package without the need for an external shaping capacitor.

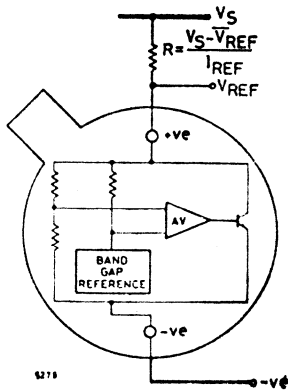

Circuit Diagram

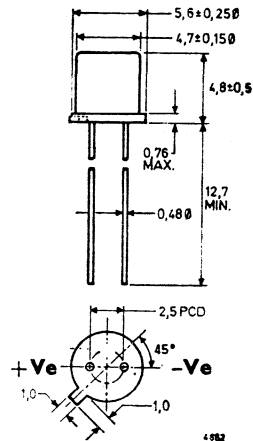

Pinning Configuration
Dimensions in millimetres

ZN458, A, B

FORWARD CHARACTERISTIC

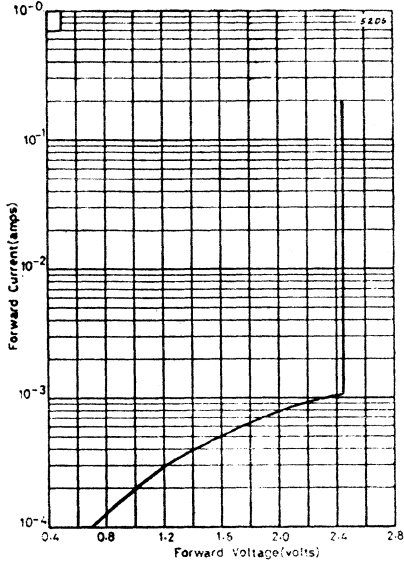

TEMPERATURE CHARACTERISTIC (Typical)

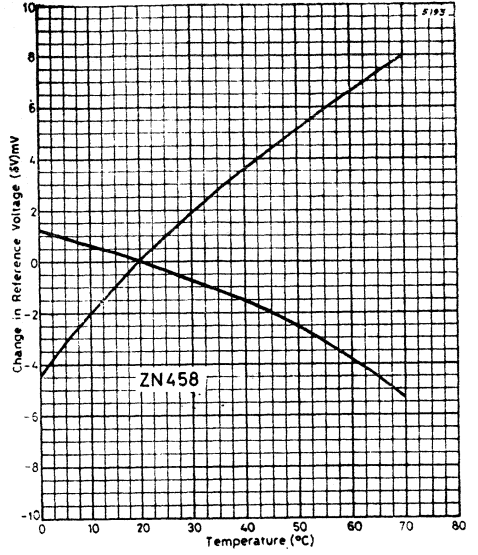

TEMPERATURE CHARACTERISTICS (Typical)

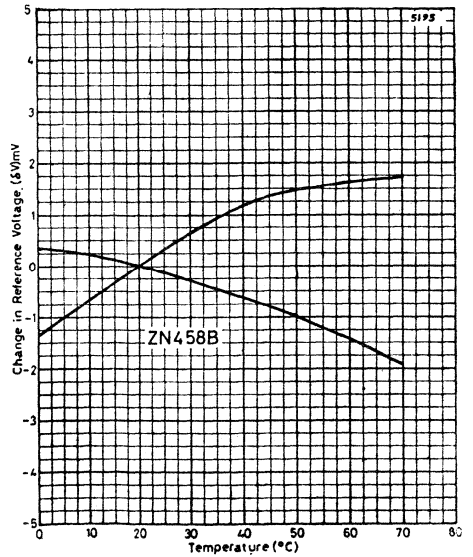
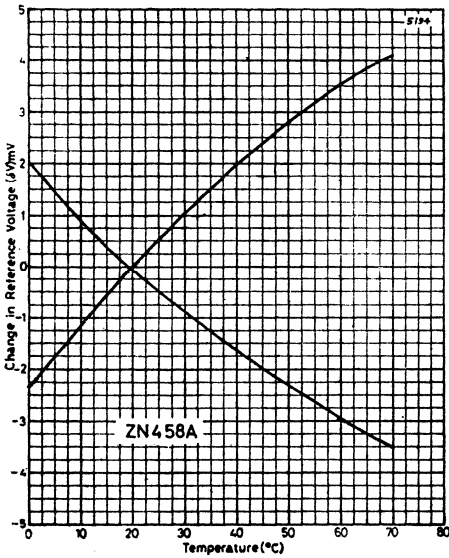

ZN458, A, B

DERATING CURVE

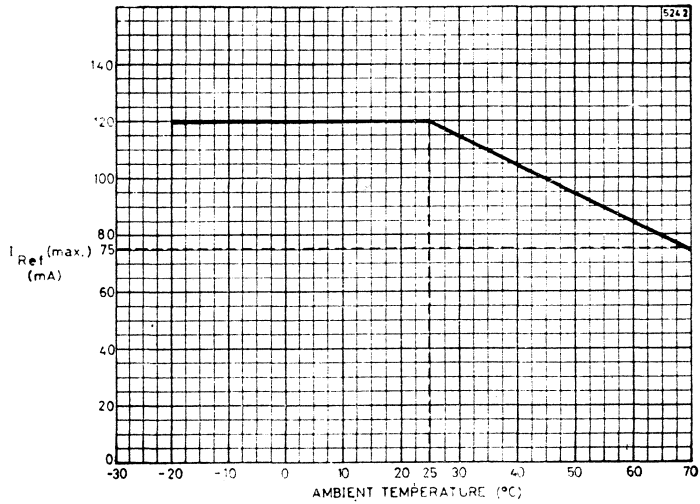

ZNREF Low Power Precision Reference Sources

ADVANCE PRODUCT INFORMATION

FEATURES

- Trimmable output
- Excellent Temperature Stability
- Low output noise figure
- Low Dynamic Impedance
- Available in three temperature ranges
- 1%, 2% and 3% initial voltage tolerance versions available

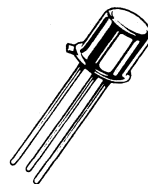

TO-18 PACKAGE



TO-39 (6 Lead) PACKAGE

DESCRIPTION

The ZNREF series is a range of monolithic integrated circuits providing precise reference voltages from 2.5 volts (ZNREFO25) to 10 volts (ZNREF100).

The range features a knee current of 150 μ A and operation over a wide range of temperatures and currents.

The devices are available in transistor packages with one of the pins offering a trim facility whereby the output voltage can be adjusted using the circuits overleaf—(Fig 2 for ZNREF100 and Fig 1 for other voltages).

ZNREF SERIES

Fig 1

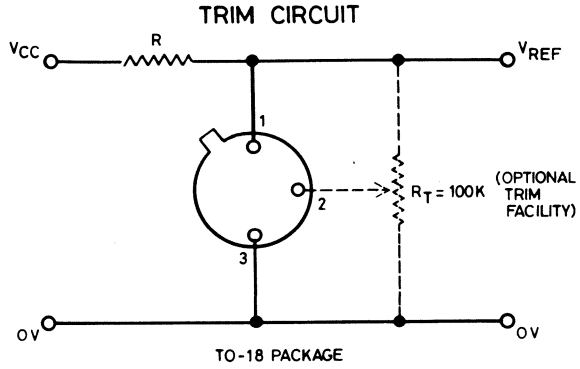
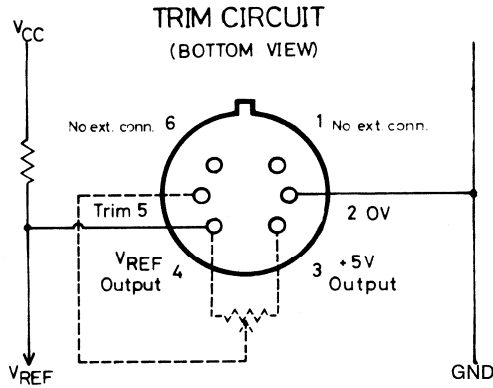

Fig 2



ZNREF SERIES

Type Number	Nominal Output Voltage (v)	Maximum Operating Current (mA)	Dynamic Impedance (Ω)		Trim Range	Package
			Typ	Max		
ZNREF025	2.49	10	1.5	2.0	$\pm 5\%$	TO-18
ZNREF040	4.01	75	2.0	3.0	$\pm 5\%$	TO-18
ZNREF050	4.98	60	1.5	2.0	$\pm 5\%$	TO-18
ZNREF062	6.17	50	2.0	3.0	$\pm 5\%$	TO-18
ZNREF100	9.96	50	3.0	4.0	$\pm 2.5\%$	6 lead TO-39

ORDERING INFORMATION

DEVICE	TOL %	T.C. PPM/ $^{\circ}\text{C}$	Temp. Range
ZNREF A1	1	50	-55°C to $+125^{\circ}\text{C}$
ZNREF A2	2		
ZNREF A3	3		
ZNREF B1	1	30	-20°C to $+85^{\circ}\text{C}$
ZNREF B2	2		
ZNREF B3	3		
ZNREF C1	1	25	0°C to $+70^{\circ}\text{C}$
ZNREF C2	2		
ZNREF C3	3		

ZNREF SERIES

PACKAGE OUTLINE

Dimensions in mm.
(TO-18)

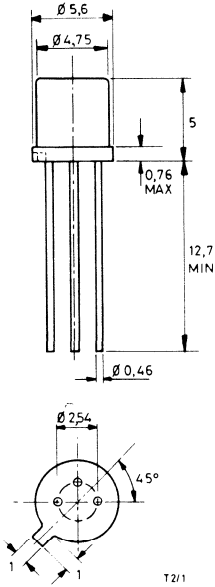

(TO-39)

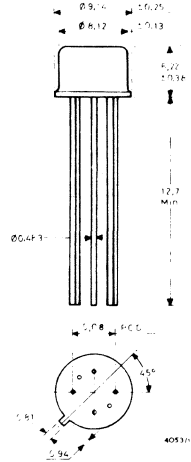

CONNECTION DIAGRAM

TO-18 Metal Can
(Bottom View)

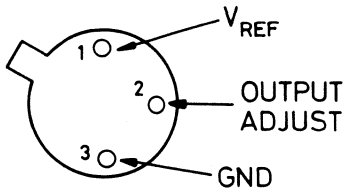

TO-39 Metal Can
(Bottom View)

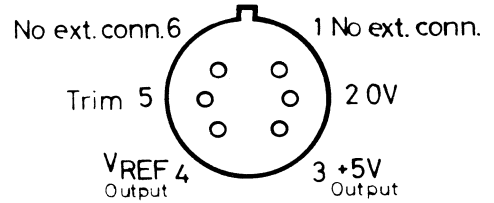

2.5 Volt Low Power Precision Reference Source
ADVANCE PRODUCT INFORMATION
FEATURES

- Trimnable output
- Excellent Temperature Stability
- Low output noise figure
- Low Dynamic Impedance
- Available in three temperature ranges
- 1%, 2% and 3% initial voltage tolerance versions available

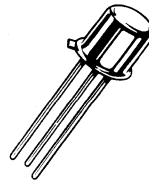
TO-18 PACKAGE
DESCRIPTION

The ZNREFO25 is a monolithic integrated circuit providing a precise, stable reference source of 2.5 volts in a three pin TO-18 metal can transistor package.

The use of the third pin is optional and enables V_{REF} to be trimmed by $\pm 5\%$. This is useful for making out system errors or setting V_{REF} to specific values, e.g. 2.500 volts for a standard calibration source or 2.56 volts for binary systems.

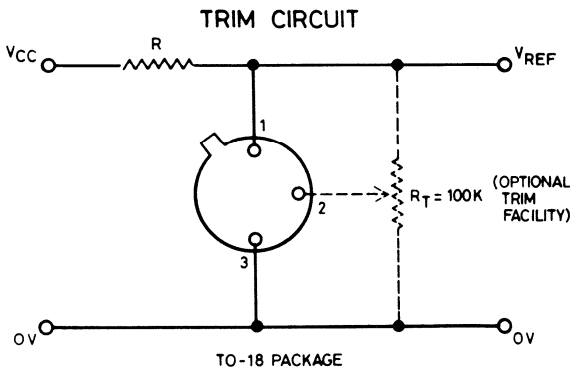

ZNREFO25

ABSOLUTE MAXIMUM RATINGS

Reference Current	10 mA
Power Dissipation	300 mW
Operating Temperature Range	See below
Storage Temperature Range	-55° to +175°C
Soldering temperature for a maximum time of 10s	
within 1/16" of the seating plane	300°C
within 1/32" of the seating plane	265°C

TEMPERATURE DEPENDANT ELECTRICAL CHARACTERISTICS

Parameter	Symbol	Initial Voltage Tolerance	Grade A -55 to 125°C		Grade B -20 to 85°C		Grade C 0-70°C		Units
			Typ	Max	Typ	Max	Typ	Max	
Output voltage change over relevant temperature range (see Note (a))	ΔV_{OT}	1%	16.0	22.5	5.0	7.5	2.7	4.4	mV
		2%							
		3%							
Output voltage temperature coefficient (See Note (b))	TCV_O	1%	35	50	20	30	15	25	ppm/ °C
		2%							
		3%							

ELECTRICAL CHARACTERISTICS ($T_A = 25^\circ\text{C}$ and Pin 2 o/c unless otherwise noted)
(LOAD should be less than 220pF or greater than 22nF)

Parameter	Symbol	Min	Typ	Max	Units	Comments
Output Voltage 1% Tolerance (A1 B1 C1) 2% Tolerance (A2 B2 C2) 3% Tolerance (A3 B3 C3)	V_O	2.465 2.440 2.415	2.49 2.49 2.49	2.515 2.540 2.565	V	$I_{REF} = 150\mu\text{A}$
Output Voltage Adjustment Range	V_{OR}	-	± 5	-	%	$R_T = 100\text{ kohms}$
Change in TCV_O with output Adjustment	TCV_{OR}	-	.8	-	ppm/ °C/%	
Turn on or "knee" current	I_{ON}	-	120	150	μA	Over full temperature range
Operating current range	I_{REF}	.15	-	10	mA	See Note (c)
Turn on settling time to within 0.1% of V_O	t_{on}	-	5	-	μSec	Overshoot typically less than 1%
Output voltage noise (over the range 0.1Hz - 10Hz)	e_{np-p}	-	50	-	μV	Peak to peak measurement
Dynamic Impedance	R_D		1.5	2.0	ohms	$I_{REF} 0.5\text{mA} - 5\text{mA}$ See Note (d)

ZNREFO25

NOTES

- a) **OUTPUT CHANGE WITH TEMPERATURE (ΔV_{OT})** the absolute difference between the maximum output voltage and the minimum output voltage over the specified temperature range

$$V_{OT} = V_{max} - V_{min}$$

- b) **OUTPUT TEMPERATURE COEFFICIENT (TCV_o)**

The ratio of the output voltage change with temperature to the specified temperature range expressed in p.p.m./°C.

$$TCV_o = \frac{\Delta V_{OT}}{V_o \times \Delta T} \times 10^6 \text{ ppm/}^\circ\text{C}$$

ΔT = Full temperature change.

- c) **OPERATING CURRENT (I_{REF})**

Maximum operating current must be derated as indicated in Maximum Ratings.

- d) **DYNAMIC IMPEDANCE (R_D)**

The dynamic impedance is defined as

$$R_D = \frac{\text{CHANGE IN } V_o \text{ OVER SPECIFIED CURRENT RANGE}}{\Delta I_{REF}}$$

$$\Delta I_{REF} = 5 - 0.5 = 4.5 \text{ mA (typically)}$$

- e) **LINE REGULATION (ΔV_{OL})**

The ratio of the change in output voltage to the change in input voltage producing it.

$$\Delta V_{OL} = \frac{R_D \times 100}{V_o \times R_s} \% / V$$

R_s = Source resistance.

DYNAMIC IMPEDANCE (TYPICAL)

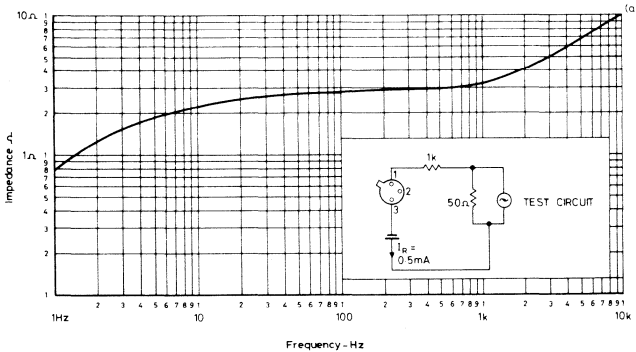

TYPICAL TEMPERATURE CHARACTERISTIC

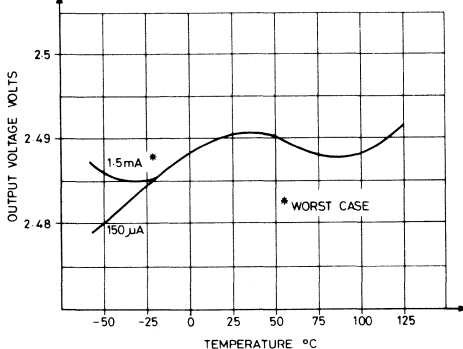

ZNREFO25

ORDERING INFORMATION

DEVICE	TOL %	T.C. PPM/°C	Temp. Range
ZNREF A1	1	50	-55°C to + 125°C
ZNREF A2	2		
ZNREF A3	3		
ZNREF B1	1	30	-20°C to +85°C
ZNREF B2	2		
ZNREF B3	3		
ZNREF C1	1	25	0°C to + 70°C
ZNREF C2	2		
ZNREF C3	3		

CONNECTION DIAGRAM TO-18 Metal Can (Bottom View)

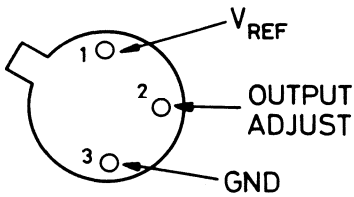

PACKAGE OUTLINE (TO-18) Dimensions in mm.

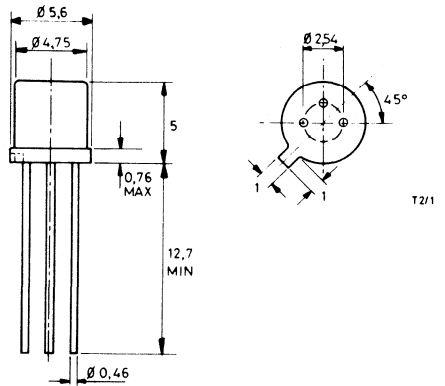

BS.3934
JEDEC

SO-12A
TO-18



4 Volt Low Power Precision Reference Source

ADVANCE PRODUCT INFORMATION

FEATURES

- Trimmable output
- Excellent Temperature Stability
- Low output noise figure
- Low Dynamic Impedance
- Available in three temperature ranges
- 1%, 2% and 3% initial voltage tolerance versions available
- No external stabilising capacitor required

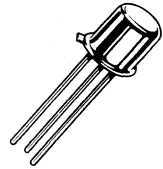

TO-18 PACKAGE

DESCRIPTION

The ZNREF040 is a monolithic integrated circuit providing a precise, stable reference source of 4 volts in a three pin TO-18 metal can transistor package.

The ZNREF040 is unconditionally stable under all load conditions without the need for an external shaping capacitor.

The use of the third pin is optional and enables V_{REF} to be trimmed by $\pm 5\%$. This is useful for taking out system errors or setting V_{REF} to specific values, e.g. 4.000 volts for a standard calibration source or 4.096 volts for binary systems.

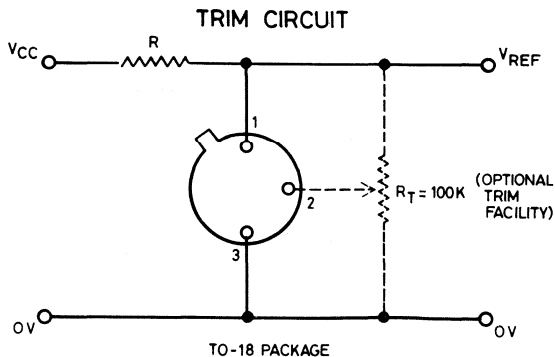

ZNREF040

ABSOLUTE MAXIMUM RATINGS

Reference Current	75mA*
Power Dissipation	300mW
Operating Temperature Range	See below
Storage Temperature Range	- 55 to + 175°C
Soldering temperature for a maximum time of 10s	
within 1/16" of the seating plane	300°C
within 1/32" of the seating plane	265°C

*Above 25°C this figure should be linearly derated to 25mA at + 125°C

TEMPERATURE DEPENDANT ELECTRICAL CHARACTERISTICS

Parameter	Symbol	Initial Voltage Tolerance %	Grade A - 55 to 125°C		Grade B - 20 to 85°C		Grade C 0 to 70°C		Units
			Typ.	Max.	Typ.	Max.	Typ.	Max.	
			Output voltage change over relevant temperature range (see Note (a))	ΔV_{OT}	1 & 2	25.6	36	8	
Output voltage temperature coefficient (See Note (b))	TCV_o	1 & 2	35	50	20	30	15	25	ppm/°C
		3	40	57	11	16.5	5.1	8.4	mV
		3	56	80	26	40	18	30	ppm/°C

ELECTRICAL CHARACTERISTICS (at $T_{amb} = 25^\circ C$ and Pin 2 o/c unless otherwise noted).

Parameter	Symbol	Min.	Typ.	Max.	Units	Comments
Output voltage	V_o or V_{REF}					} $I_{REF} = 150\mu A$
1% Tolerance (A1 B1 C1)		3.97	4.01	4.05	V	
2% Tolerance (A2 B2 C2)		3.93	4.01	4.09	V	
3% Tolerance (A3 B3 C3)		3.98	4.01	4.13	V	
Output voltage adjustment range	V_{OR}	-	± 5	-	%	$R_T = 100k\Omega$
Change in TCV_o with output adjustment	TCV_{OR}	-	0.8	-	ppm/°C/%	
Turn-on or "knee" current	I_{ON}	-	120	150	μA	Over full temperature range
Operating current range	I_{REF}	0.15	-	75	mA	See Note (c)
Turn-on settling time to within 0.1% of V_o	t_{on}	-	5	-	μsec	Overshoot typically less than 1%
Output voltage noise (over the range 0.1 Hz to 10 Hz)	e_{np-p}	-	50	-	μV	Peak to peak measurement
Dynamic Impedance	R_D	-	2	3	Ω	$I_{REF} 0.5mA$ to 5mA See Note (d)

NOTES

(a) **OUTPUT CHANGE WITH TEMPERATURE (ΔV_{OT})** the absolute difference between the maximum output voltage and the minimum output voltage over the specified temperature range

$$\Delta V_{OT} = V_{\max} - V_{\min}$$

(b) **OUTPUT TEMPERATURE COEFFICIENT (TCV_o)**

The ratio of the output voltage change with temperature to the specified temperature range expressed in ppm/°C.

$$TCV_o = \frac{\Delta V_{OT} \times 10^6}{V_o \times \Delta T} \text{ ppm/}^\circ\text{C}$$

ΔT = Full temperature change.

(c) **OPERATING CURRENT (I_{REF})**

Maximum operating current must be derated as indicated in Maximum Ratings.

(d) **DYNAMIC IMPEDANCE (R_D)**

The dynamic impedance is defined as

$$R_D = \frac{\text{CHANGE IN } V_o \text{ OVER SPECIFIED CURRENT RANGE}}{\Delta I_{REF}}$$

$\Delta I_{REF} = 5 - 0.5 = 4.5 \text{ mA (typically)}$

(e) **LINE REGULATION (ΔV_{OL})**

The ratio of the change in output voltage to the change in input voltage producing it.

$$\Delta V_{OL} = \frac{R_D \times 100}{V_o \times R_S} \% / V$$

R_S = Source resistance

DYNAMIC IMPEDANCE (TYPICAL)

DATA NOT AVAILABLE
AT TIME OF PRINTING

TYPICAL TEMPERATURE CHARACTERISTIC

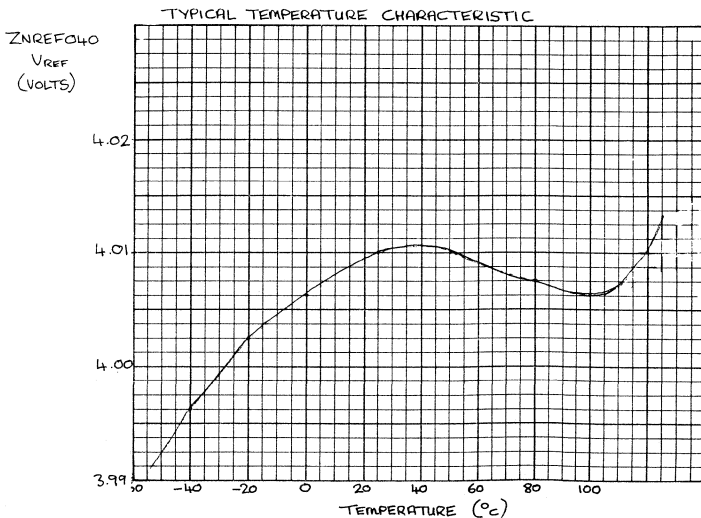

ZNREF040

ORDERING INFORMATION

DEVICE	TOLERANCE (%)	T.C. (Max) – ppm/°C	Temperature Range
ZNREF040 A1	1	50	– 55°C to + 125°C
ZNREF040 A2	2		
ZNREF040 A3	3		
ZNREF040 B1	1	30	– 20°C to + 85°C
ZNREF040 B2	2		
ZNREF040 B3	3		
ZNREF040 C1	1	25	0°C to + 70°C
ZNREF040 C2	2		
ZNREF040 C3	3		

CONNECTION DIAGRAM
TO-18 Metal Can (Bottom View)

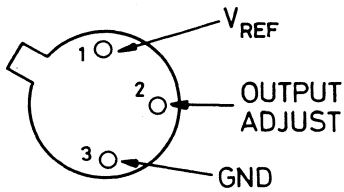

PACKAGE OUTLINE
(TO-18) Dimensions in mm.

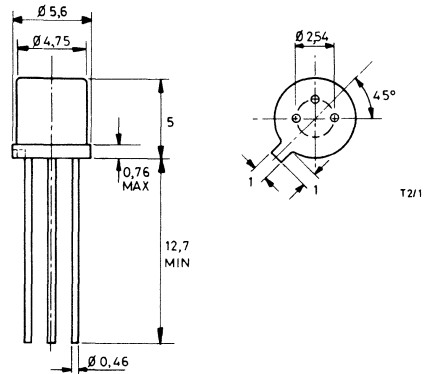

BS.3934
JEDEC

SO-12A
TO-18

5 Volt Low Power Precision Reference Source
ADVANCE PRODUCT INFORMATION
FEATURES

- Trimmable output
- Excellent Temperature Stability
- Low output noise figure
- Low Dynamic Impedance
- Available in three temperature ranges
- 1%, 2% and 3% initial voltage tolerance versions available
- No external stabilising capacitor required

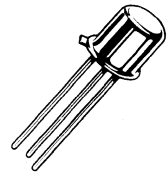
TO-18 PACKAGE
DESCRIPTION

The ZNREF050 is a monolithic integrated circuit providing a precise, stable reference source of 5 volts in a three pin TO-18 metal can transistor package.

The ZNREF050 is unconditionally stable under all load conditions without the need for an external shaping capacitor.

The use of the third pin is optional and enables V_{REF} to be trimmed by $\pm 5\%$. This is useful for taking out system errors or setting V_{REF} to specific values, e.g. 5.000 volts for a standard calibration source or 5.12 volts for binary systems.

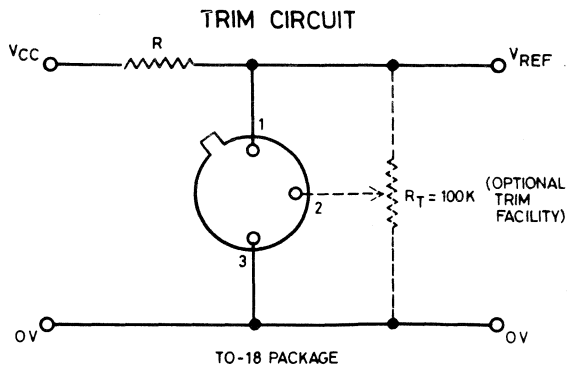

ZNREF050

ABSOLUTE MAXIMUM RATINGS

Reference Current	60 mA
Power Dissipation	300 mW
Operating Temperature Range	See below
Storage Temperature Range	-55° to +175°C
Soldering temperature for a maximum time of 10s	
within 1/16" of the seating plane	300°C
within 1/32" of the seating plane	265°C

TEMPERATURE DEPENDANT ELECTRICAL CHARACTERISTICS

Parameter	Symbol	Initial Voltage Tolerance	Grade A -55 to 125°C		Grade B -20 to 85°C		Grade C 0-70°C		Units
			Typ	Max	Typ	Max	Typ	Max	
Output voltage change over relevant temperature range (see Note (a))	ΔV_{OT}	1% 2%	32	45	10	15	5.4	8.8	mV
		3%	51	72	15.7	25.9	8.4	14.4	
Output voltage temperature coefficient (See Note (b))	TCV _O	1% 2%	35	50	20	30	15	25	ppm/ °C
		3%	57	80	30	48	24	40	

ELECTRICAL CHARACTERISTICS (T_A = 25°C and Pin 2 o/c unless otherwise noted)

Parameter	Symbol	Min	Typ	Max	Units	Comments
Output Voltage 1% Tolerance (A1 B1 C1) 2% Tolerance (A2 B2 C2) 3% Tolerance (A3 B3 C3)	V _O	4.93 4.88 4.83	4.98 4.98 4.98	5.03 5.08 5.13	V	I _{REF} = 150μA
Output Voltage Adjustment Range	V _{OR}	-	±5	-	%	R _T = 100 kohms
Change in TCV _O with output Adjustment	TCV _{OR}	-	.8	-	ppm/ °C/%	
Turn on or "knee" current	I _{ON}	-	120	150	μA	Over full temperature range
Operating current range	I _{REF}	.15	-	60	mA	See Note (c)
Turn on settling time to within 0.1% of V _O	ton	-	5	-	μSec	Overshoot typically less than 1%
Output voltage noise (over the range 0.1Hz-10Hz)	e _{np-p}	-	50	-	μV	Peak to peak measurement
Dynamic Impedance	R _D		1.5	2	ohms	I _{REF} 0.5mA - 5mA See Note (d)

ZNREFO50

NOTES

- a) **OUTPUT CHANGE WITH TEMPERATURE (ΔV_{OT})** the absolute difference between the maximum output voltage and the minimum output voltage over the specified temperature range

$$V_{OT} = V_{max} - V_{min}$$

- b) **OUTPUT TEMPERATURE COEFFICIENT (TCV_o)**

The ratio of the output voltage change with temperature to the specified temperature range expressed in p.p.m./°C.

$$TCV_o = \frac{\Delta V_{OT}}{V_o} \times 10^6 \text{ ppm}/^\circ\text{C}$$

ΔT = Full temperature change.

- c) **OPERATING CURRENT (I_{REF})**

Maximum operating current must be derated as indicated in Maximum Ratings.

- d) **DYNAMIC IMPEDANCE (R_D)**

The dynamic impedance is defined as

$$R_D = \frac{\text{CHANGE IN } V_o \text{ OVER SPECIFIED CURRENT RANGE}}{\Delta I_{REF}}$$

$$\Delta I_{REF} = 5 - 0.5 = 4.5 \text{ mA (typically)}$$

- e) **LINE REGULATION (ΔV_{OL})**

The ratio of the change in output voltage to the change in input voltage producing it.

$$\Delta V_{OL} = \frac{R_D \times 100}{V_o \times R_s} \% / V$$

R_s = Source resistance.

DYNAMIC IMPEDANCE (TYPICAL)

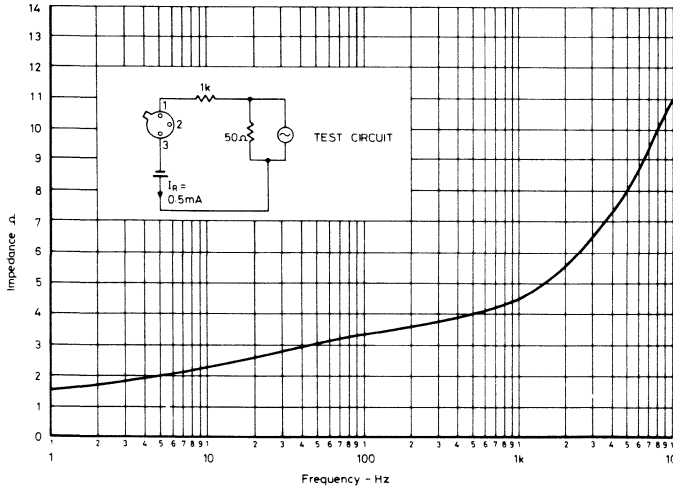

TYPICAL TEMPERATURE CHARACTERISTIC

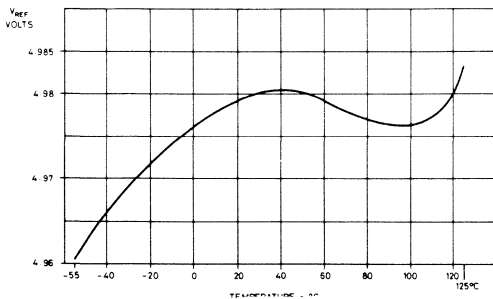

ZNREFO50

ORDERING INFORMATION

DEVICE	TOL %	T.C. PPM/°C	Temp. Range
ZNREF A1	1	50	-55°C to + 125°C
ZNREF A2	2		
ZNREF A3	3		
ZNREF B1	1	30	-20°C to +85°C
ZNREF B2	2		
ZNREF B3	3		
ZNREF C1	1	25	0°C to 70°C
ZNREF C2	2		
ZNREF C3	3		

CONNECTION DIAGRAM
TO-18 Metal Can (Bottom View)

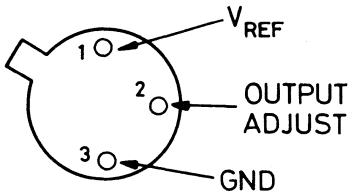

PACKAGE OUTLINE
(TO-18) Dimensions in mm.

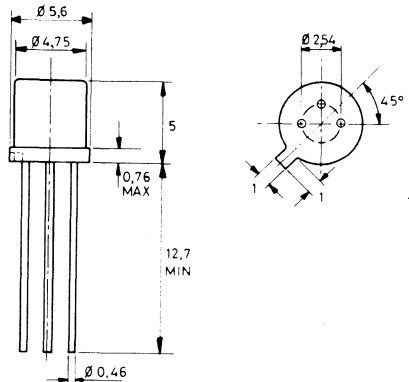

BS.3934
JEDEC

SO-12A
TO-18



FERRANTI
semiconductors

ZNREF 100

10 Volt Low Power Precision Reference Source

ADVANCE PRODUCT INFORMATION

FEATURES

- Trimnable output
- Excellent Temperature Stability
- Low output noise figure
- Low Dynamic Impedance
- Available in three temperature ranges
- 1%, 2% and 3% initial voltage tolerance versions available
- No external stabilising capacitor required



TO-39 (6 Lead) PACKAGE

DESCRIPTION

The ZNREF100 is a monolithic integrated circuit providing a precise, stable reference source of 10 volts in a six pin TO-39 metal can transistor package.

The ZNREF100 is unconditionally stable under all load conditions without the need for an external shaping capacitor.

The use of the third pin is optional and enables V_{REF} to be trimmed by $\pm 2.5\%$. This is useful for taking out system errors or setting V_{REF} to specific values, e.g. 10,000 volts for a standard calibration source or 10.24 volts for binary systems.

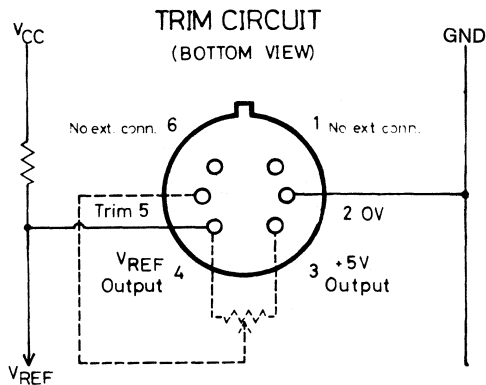

ZNREF100

ABSOLUTE MAXIMUM RATINGS

Reference Current	50 mA
Power Dissipation	500 mW
Operating Temperature Range	See below
Storage Temperature Range	-55° to +175°C
Soldering temperature for a maximum time of 10s	
within 1/16" of the seating plane	300°C
within 1/32" of the seating plane	265°C

TEMPERATURE DEPENDANT ELECTRICAL CHARACTERISTICS

Parameter	Symbol	Initial Voltage Tolerance	Grade A		Grade B		Grade C		Units
			-55 to 125°C		-20 to 85°C		0-70°C		
			Typ	Max	Typ	Max	Typ	Max	
Output voltage change over relevant temperature range (see Note (a))	ΔV_{OT}	1% 2%	64	90	20	30	10.8	17.6	mV
		3%	102	144	31	51	16	29	
Output voltage temperature coefficient (See Note (b))	TCV _O	1% 2%	35	50	20	30	15	25	ppm/ °C
		3%	57	80	30	48	24	40	

ELECTRICAL CHARACTERISTICS (T_A = 25°C and Pin 2 o/c unless otherwise noted)

Parameter	Symbol	Min	Typ	Max	Units	Comments
Output Voltage 1% Tolerance (A1 B1 C1) 2% Tolerance (A2 B2 C2) 3% Tolerance (A3 B3 C3)	V _O	9.86 9.76 9.96	9.96 9.96 9.96	10.06 10.16 10.26	V	I _{REF} = 150μA
Output Voltage Adjustment Range	V _{OR}	—	±2.5	—	%	R _T = 100 kohms
Change in TCV _O with output Adjustment	TCV _{OR}	—	.8	—	ppm/ °C/%	
Turn on or "knee" current	I _{ON}	—	120	150	μA	Over full temperature range
Operating current range	I _{REF}	.15	—	50	mA	See Note (c)
Turn on settling time to within 0.1% of V _O	ton	—	5	—	μSec	Overshoot typically less than 1%
Output voltage noise (over the range 0.1Hz-10Hz)	e _{np-p}	—	50	—	μV	Peak to peak measurement
Dynamic Impedance	R _D		3	4	ohms	I _{REF} 0.5mA-5mA See Note (d)

NOTES

ZNREF100

- a) **OUTPUT CHANGE WITH TEMPERATURE (ΔV_{OT})** the absolute difference between the maximum output voltage and the minimum output voltage over the specified temperature range

$$V_{OT} = V_{max} - V_{min}$$

- b) **OUTPUT TEMPERATURE COEFFICIENT (TCV_o)**

The ratio of the output voltage change with temperature to the specified temperature range expressed in p.p.m./°C.

$$TCV_o = \frac{\Delta V_{OT}}{V_o} \times 10^6 \text{ ppm/}^\circ\text{C}$$

ΔT = Full temperature change.

- c) **OPERATING CURRENT (I_{REF})**

Maximum operating current must be derated as indicated in Maximum Ratings.

- d) **DYNAMIC IMPEDANCE (R_D)**

The dynamic impedance is defined as

$$R_D = \frac{\text{CHANGE IN } V_o \text{ OVER SPECIFIED CURRENT RANGE}}{\Delta I_{REF}}$$

$$\Delta I_{REF} = 5 - 0.5 = 4.5 \text{ mA (typically)}$$

- e) **LINE REGULATION (ΔV_{OL})**

The ratio of the change in output voltage to the change in input voltage producing it.

$$\Delta V_{OL} = \frac{R_D \times 100}{V_o \times R_s} \% / V$$

R_s = Source resistance.

DYNAMIC IMPEDANCE (TYPICAL)

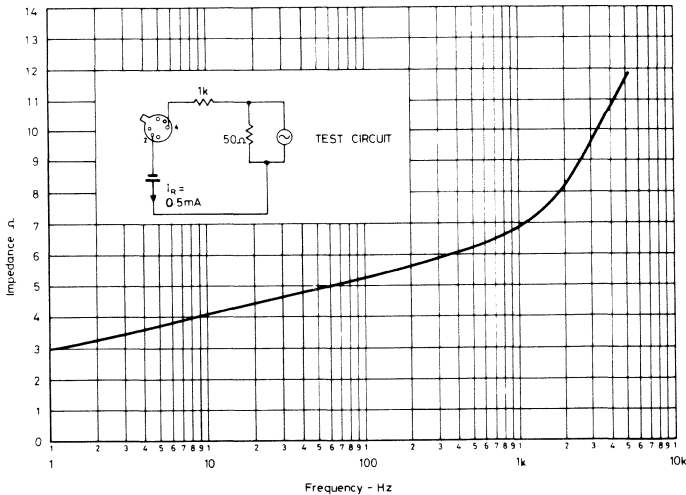

TYPICAL TEMPERATURE CHARACTERISTIC

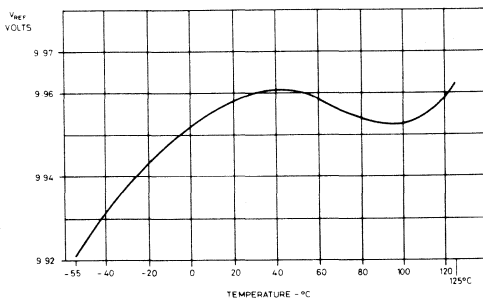

ZNREF100

ORDERING INFORMATION

DEVICE	TOL %	T.C. Ppm/°C	Temp. Range
ZNREF A1	1	50	-55°C to + 125°C
ZNREF A2	2		
ZNREF A3	3		
ZNREF B1	1	30	-20°C to +85°C
ZNREF B2	2		
ZNREF B3	3		
ZNREF C1	1	25	0°C to 70°C
ZNREF C2	2		
ZNREF C3	3		

CONNECTION DIAGRAM TO-39 Metal Can (Bottom View)

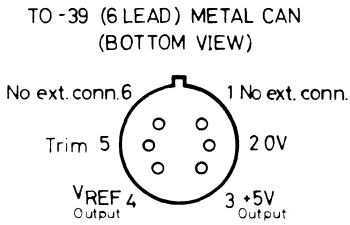

PACKAGE OUTLINE (TO-39) Dimensions in mm.

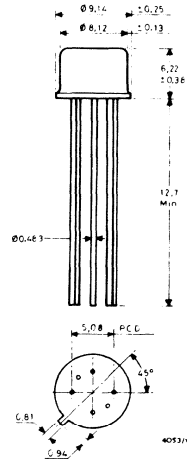

TO-39 (6 Lead) PACKAGE

4. Codec Circuits

Contents

	page
ZN PCM 1	4-3
ZN PCM 2	4-17



FERRANTI
semiconductors

ZNPCM1

A Single Channel Codec Integrated Circuit

FEATURES

- Converts a delta-sigma modulated digital pulse stream into compressed 'A' law pcm and vice-versa.
- Enables realisation of a single channel codec circuit with minimum component usage.
- Pin selectable input/output interface providing either single channel operation at 64K bit/s (2,048 kHz external clock) or up to 2,048K bit/s (2,048 kHz external clock) for multi-channel burst format.
- Encoder and decoder can be clocked asynchronously (useful for pcm multiplex applications).
- Optional alternate digit inversion.
- Electrically and pin compatible with AY-3-9900
- Fully TTL compatible.
- Requires only a single 5V supply.

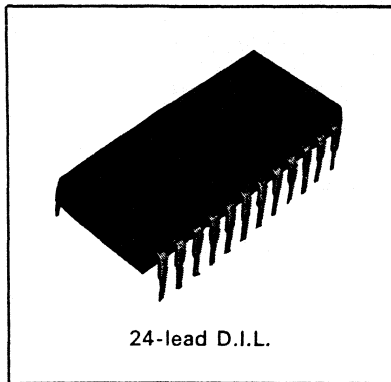

24-lead D.I.L.

DESCRIPTION

The ZNPCM1 integrated circuit is the result of a joint development programme between the British Post Office and Ferranti Electronics Limited. Designed for use in single channel codec systems the device accepts a delta-sigma modulated pulse stream at 2,048K bit/s (2,048 kHz external clock) and converts it into 8K sample/s compressed 'A' law pcm. In the decode direction the device performs the reverse function. A flexible serial pcm input/output interface is provided allowing operation in a single channel mode at 64K bit/s or at up to 2,048K bit/s (2,048 kHz external clock) for a multi-channel burst format. Digit delay control is provided to compensate for transmission delays. Optional alternate digit inversion is provided and the encoder and decoder can be clocked asynchronously if required for use in pcm multiplex applications.

Designed for use with a 2,048 kHz system clock, when operated with the required delta-sigma modulator and demodulator (see application report 'a single channel codec') The device performance complies with B.P.O. specification RC5549B and CCITT recommendations G711/G712 (1972).

The ZNPCM1 is guaranteed to operate up to 2,048 kHz and will typically operate up to 4 MHz. Operation is from a single 5V power supply with a typical power dissipation of 400 mW. All inputs and outputs are TTL compatible. Available in either a 24-lead ceramic (ZNPCM1J) or moulded (ZNPCM1CE) dual in-line package, the device is designed to operate over the temperature range 0°C to +70°C.

ZNPCM1

ABSOLUTE MAXIMUM RATINGS

Supply Voltage, V_{CC}	+7 Volts
Input Voltage, V_{IN}	+5.5 Volts
Operating Temperature Range	0°C to +70°C
Storage Temperature Range	-65°C to +150°C

RECOMMENDED OPERATING CONDITIONS

Parameter	Min.	Nom.	Max.	Unit
Supply Voltage, V_{CC}	4.75	5.0	5.25	V
High-level Output Current, I_{OH}	—	—	-400	μ A
Low-level Output Current, I_{OL}	—	—	4	mA
Operating Temperature Range, T_{amb}	0	—	70	°C

ELECTRICAL CHARACTERISTICS (over recommended operating temperature range).

Parameter	Test Conditions	Min.	Typ.	Max.	Unit
V_{IH} High level input voltage		2.5	—	—	V
V_{IL} Low level input voltage		—	—	0.8	V
V_{OH} High level output voltage	$V_{CC} = \text{Min.}, I_{OH} = \text{Max.}$	2.4	3.5	—	V
V_{OL} Low level output voltage	$V_{CC} = \text{Min.}, I_{OL} = \text{Max.}$	—	—	0.4	V
I_{IH} High level input current	$V_{CC} = \text{Max.}, V_{IH} = \text{Min.}$	—	0.2	0.4	mA
I_{IL} Low level input current	$V_{CC} = \text{Max.}, V_{IL} = \text{Max.}$	—	-1	-10	μ A
I_{CC} Supply current	$V_{CC} = \text{Max.}$	—	80	110	mA
t_{vw} Encoder timing vector pulse width		—	488	—	ns
t_v Encoding timing vector pulse width with edge variation		—	—	100	ns
t_{ww} Decoder timing waveform pulse width		10	15.6	—	μ s
f_{max} Operating frequency		2.048	4	—	MHz
t_r & t_f Rise and fall times	0.4V to 3V Transition	5	—	40	ns
t_{pw} Pulse width	Between 1.5V levels	200	—	—	ns
C_I Input capacitance		—	—	10	pF

ZNPCM1

PIN CONFIGURATIONS

Pin	Notation	Comments															
1	0V																
2	MS	MODE SELECT (Note 1) Logic 0 = External pcm I/O interface timing Logic 1 = Internal pcm I/O interface timing															
3	DS1	DECODER SELECT 1 and 2 (Note 2)															
4	DS2	A two bit binary word selects required digit delay between encoder and decoder. <table style="margin-left: auto; margin-right: auto;"> <thead> <tr> <th>DS1</th> <th>DS2</th> <th>Digit Delay</th> </tr> </thead> <tbody> <tr> <td>0</td> <td>0</td> <td>0</td> </tr> <tr> <td>0</td> <td>1</td> <td>1</td> </tr> <tr> <td>1</td> <td>0</td> <td>2</td> </tr> <tr> <td>1</td> <td>1</td> <td>3</td> </tr> </tbody> </table>	DS1	DS2	Digit Delay	0	0	0	0	1	1	1	0	2	1	1	3
DS1	DS2	Digit Delay															
0	0	0															
0	1	1															
1	0	2															
1	1	3															
5	ADI	ALTERNATE DIGIT INVERSION Logic 0 = No. ADI Logic 1 = ADI															
6	N.C.	NO CONNECTION															
7	0V																
8	V _{CC}																
9	DSMO	DELTA-SIGMA MODULATED OUTPUT SIGNAL															
10	SGN	SIGN BIT OUTPUT Sign bit from the encoder, used to operate on the delta-sigma modulator to reduce d.c. offset effects.															
11	DSMI	DELTA-SIGMA MODULATED INPUT															
12	SRF	SPECTRAL REDISTRIBUTION FUNCTION Output signal used to operate on the delta-sigma modulator to reduce low frequency quantisation noise.															
13	PCMO	PCM OUTPUT															
14	SGBI	SIGNALLING BIT INPUT Facility for adding signalling bit(s) to the output pcm stream.															
15	ETV	ENCODER TIMING VECTOR A pulse defining the beginning of each frame used to maintain encoder timing.															
16	PCMI	PCM INPUT															
17	SGBO	SIGNALLING BIT OUTPUT Serial output for extracting signalling bit(s) from the incoming pcm stream.															

ZNPCM1

PIN CONFIGURATIONS (continued)

Pin	Notation	Comments
18	DTW	DECODER TIMING WAVEFORM A pulse used to indicate to the decoder when the input pcm stream is in the input register (required only when external shift clocks are used).
19	SCE	ENCODER SHIFT CLOCK Used to control the output of serial pcm data from the encoder (when MS is low).
20	CLKD	DECODER MAIN CLOCK
21	CLKE	ENCODER MAIN CLOCK
22	SCD	DECODER SHIFT CLOCK Used to control the input of the serial pcm data to the decoder (when MS is low).
23	N.C.	NO CONNECTION
24	I.C.	INTERNAL CONNECTION Make no external connection to this pin.

Notes:

1. With MS low (logic 0) serial PCM transmission is under the control of an externally generated shift clock SCE which can vary from 64 kHz to 2,048 kHz. The timing of this input function allows the insertion of a number of signalling bits into the PCM stream via the SGB1 input. In the high (logic 1) state the 8 bit PCM codeword will be transmitted at a rate of 64K bit/sec and each codeword will occupy the full 125 μ s frame period with the leading edge of the first bit occurring at a time defined by the ETV pulse.
2. Delays through the transmission network, normally under the control of transmission switches, may cause the decoder input pulse stream to be delayed in time by a number of digits from the original transmitted pulse. To compensate for this delay two control inputs, DS1 and DS2, are provided. Consequently when MS is in the high state discrete digit delays of 0 to 3 periods may be selected resulting in a controlled shift of decoder timing in order to re-align Bit 1 in its correct position in the input register.
When using an externally generated clock (i.e. MS in low state) an input shift clock (SCD) and timing waveform (DTW) are required to ensure that Bit 1 of the input codeword occupies its correct position in the input shift register.

FUNCTIONAL DIAGRAM

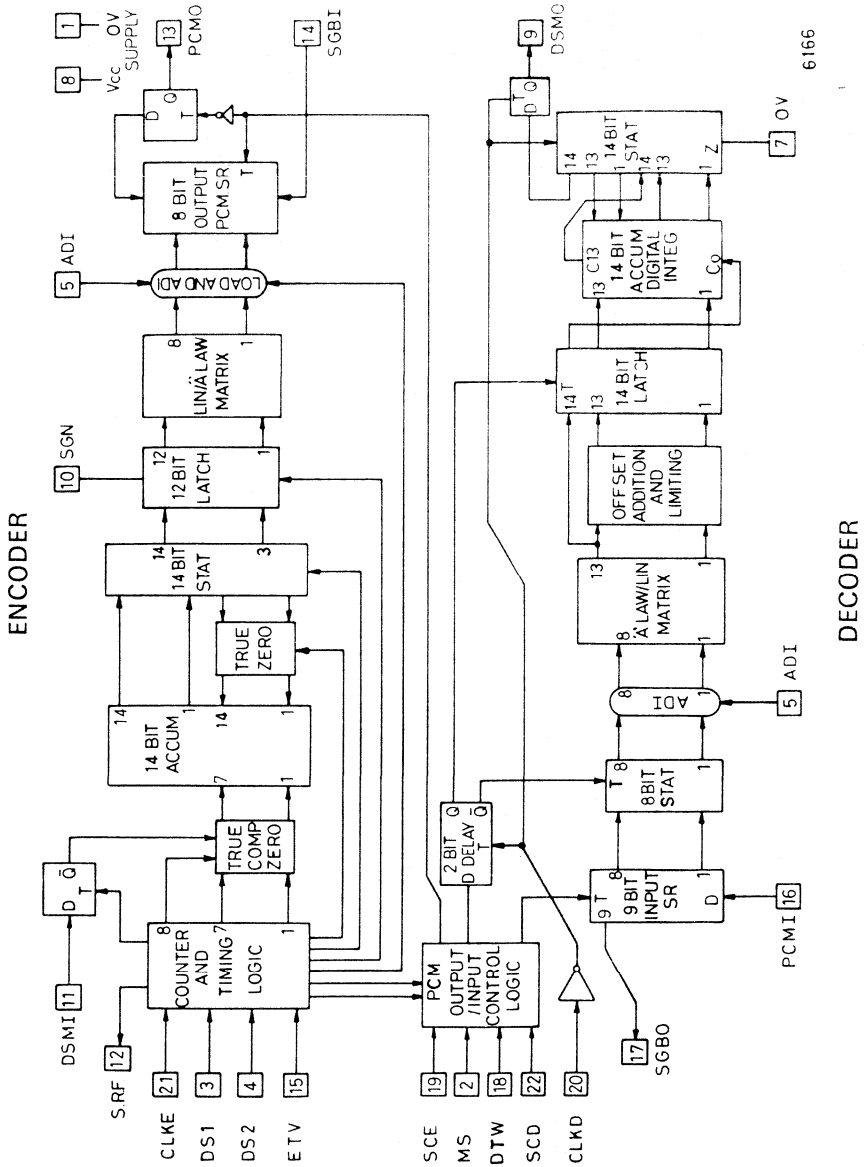

6166

ZNPCM1

TIMING DIAGRAM ENCODER

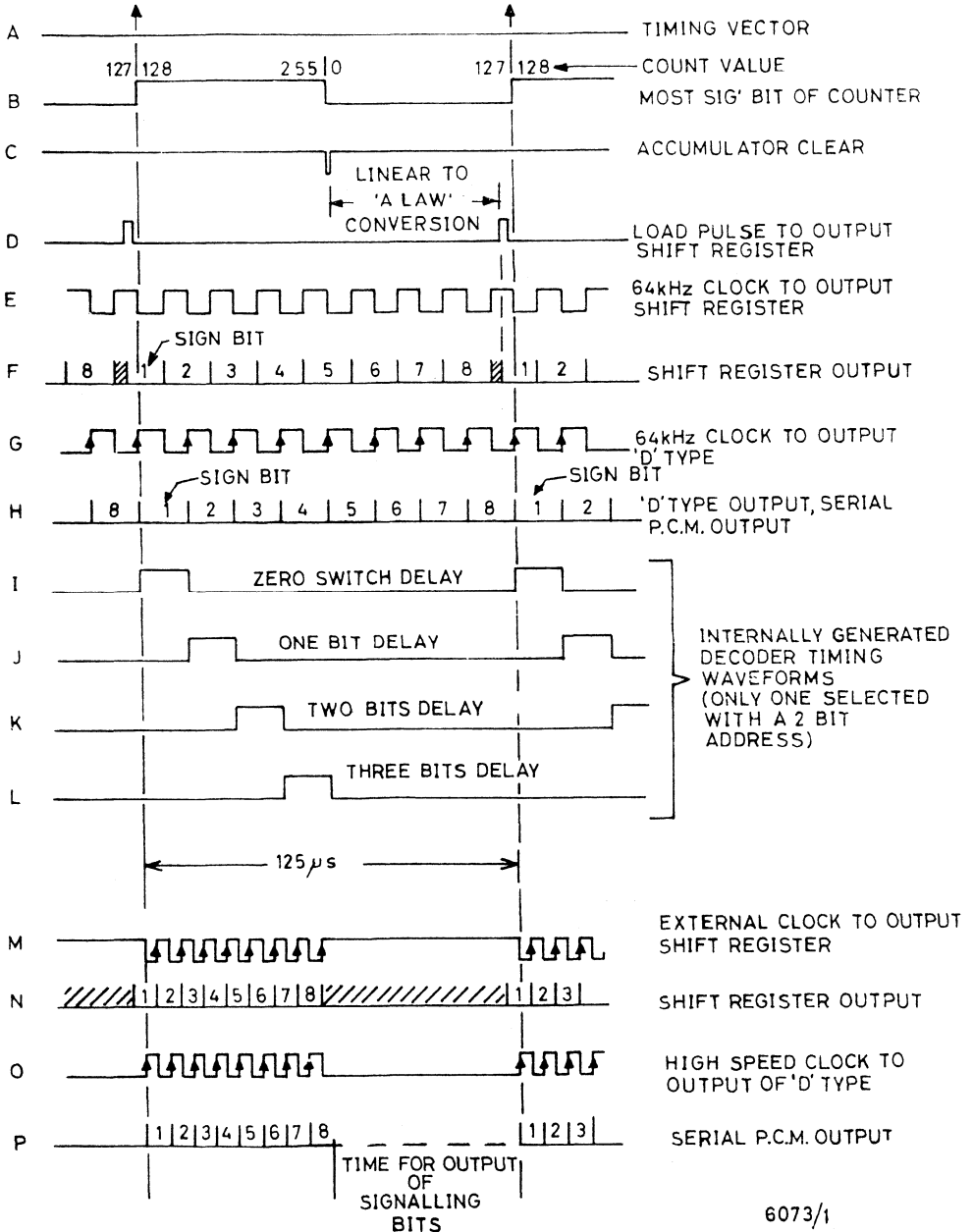

6073/1

TIMING DIAGRAM DECODER

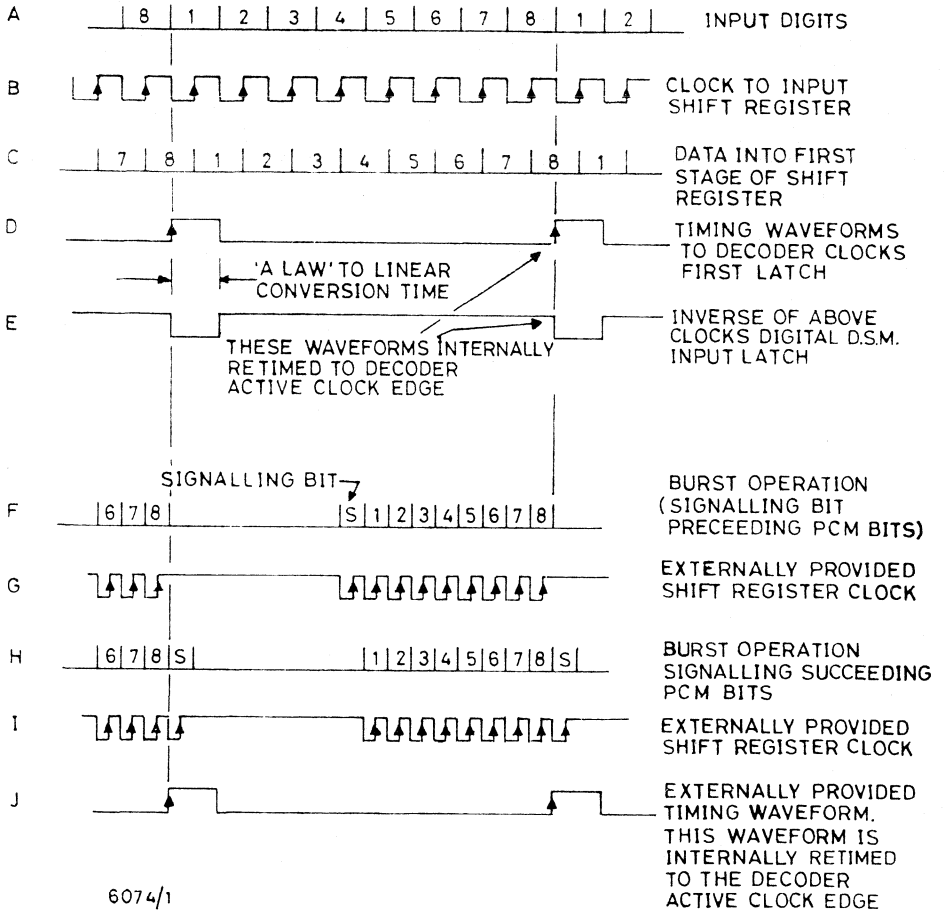

ZNPCM1

APPLICATIONS INFORMATION

(a) A Single Channel Codec

Fig. 1 shows a block diagram of a single channel Codec using the ZNPCM1. The circuit accepts a band limited analogue input signal (300 – 3,400 kHz) and converts it to one bit/sample delta sigma code format at a high sampling rate. The dsm bit stream is then converted by the ZNPCM1 into 8-bit compressed pulse code modulation (pcm) code words at the standard rate of 8K samples/sec, which is then converted into serial format for transmission serially at 64K bit/sec. External timing signals can be used to increase the transmission bit rate to 2,048K bit/sec. to allow for multiplexing in a burst format (see application b).

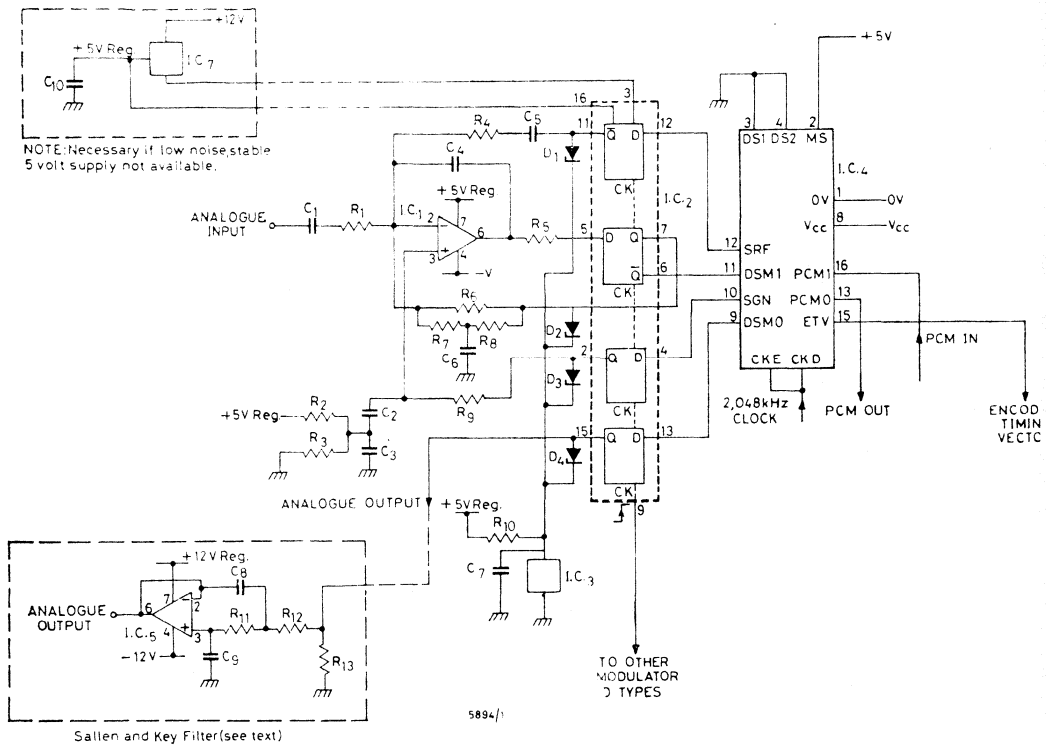

Fig. 1.

The pcm input interface will accept either a 64K bit/sec. bit stream or, by the application of external timing signals, a bit rate of 2,048K bit/sec. in burst format. This is then converted by the ZNPCM1 into a dsm bit stream at 2,048K bit/sec. The dsm demodulator accepts this bit stream and produces one of two precisely defined analogue levels per single bit sample. The analogue waveform can then be recovered via a low pass filter, cutting off just above the highest signal frequency to be recovered (3.4 kHz).

ZNPCM1

Output voltages of the dsm circuit are stabilised by supplying the quad D-type from a 5 volt regulator, which is always associated with the Codec, and clamping the high state output voltages to a 2.45V reference by the use of Schottky diodes. These also help to match the voltages influencing the d.c. alignment conditions and minimise the effects of power supply variations and noise. Resistor ratio stability is obtained, along with a small modulator/demodulator physical size by implementing the resistors and small capacitors as an in-line hybrid. More details of the operation of the dsm circuit are outlined in the Ferranti brochure 'A Single Channel Codec'.

An interesting development, again in co-operation with the British Post Office, is the integrated circuit dsm solution now approaching completion. This will reduce the circuitry surrounding the ZNPCM1 to a single I.C. and seven capacitors, the latter almost certainly to be made available as a single in-line hybrid.

The Codec performance related to CCITT criteria is outlined in Fig. 2.

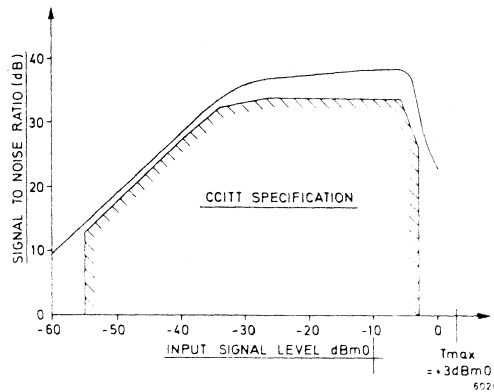

Fig. 2.

(b) A 30 Channel PCM Codec Solution

Traditionally the code conversion process on branch-to-main telephone exchange systems has been performed using multiplexed codecs. Historically the reason for this has been the codec specification where the signal-to-noise and gain-linearity constraints imposed on the systems have resulted in the use of expensive hybrid codecs. It might seem immediately obvious that the use of single channel codecs offers a more attractive solution, however a comparison of one of the major performance criteria is first of all necessary, that of power dissipation. Indeed, an initial comparison using the conventional 30 Channel PCM system shows the single channel codec approach to disadvantage. However, a more detailed analysis, using the single channel codecs in a power switching mode, shows this technique to be compatible with time shared codecs. This is described in section (d).

Let us first of all consider the system approach for using the single channel codecs in a 30 Channel PCM system by looking at Fig. 3.

ZNPCM1

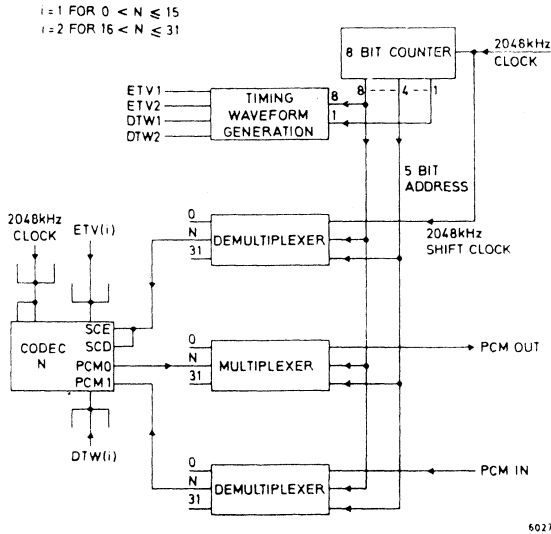

Fig. 3.

Fig. 3 shows how a 32 time slot (Note: A 30 Channel system has in fact, 32 time slots, the two additional ones being for signalling notation and synchronisation), 2,048K bit/sec. multiplex can be formed and decoded using 30 single channel codecs, when the two directions of transmission operate synchronously. Only the Nth codec is shown, connected to the 'Nth' port of the 32 port multiplexer and demultiplexers. When the 5-bit address equals N the 2,048 kHz shift clock is routed through the 'Nth' codec for eight clock pulses as shown in Fig. 4(a). The shift-in and shift-out clock terminals of the codec are commoned together. Since the shift-out terminal uses a negative active clock edge and the shift-in terminal uses a positive active clock edge the pcm digits for the two directions may be in exact time alignment. This is compatible with using the same 5-bit address for the multiplexer and the other demultiplexer.

The Encoder Timing Vector (ETV) and the Decoder Timing Waveform (DTW) may be derived from a counter driven by the 2,048 kHz clock and commoned across a number of codecs. For a 32 time slot multiplex, two sets of ETV's and DTW's should be generated with a half frame displacement as shown in Figs. 4(b) and 4(c). The first pair will supply ports 0 to 15 and the second pair ports 16 to 31, and consequently allowing the shift activity to be kept well clear of the timing waveforms for a given codec.

For a conventional 32 time slot codec ports 0 and 16 correspond to the synchronisation and signalling channels respectively.

Fig. 5 shows a similar arrangement for generating and decoding a 32 time slot multiplex when the two directions of transmission operate asynchronously. The two directions are operated quite independently but using similar principals to those previously discussed. It should again be noted that two sets of ETV's and DTW's should be used.

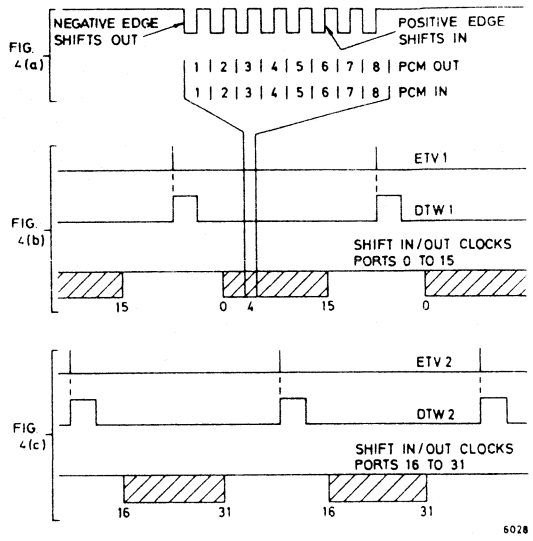

6028

Fig. 4.

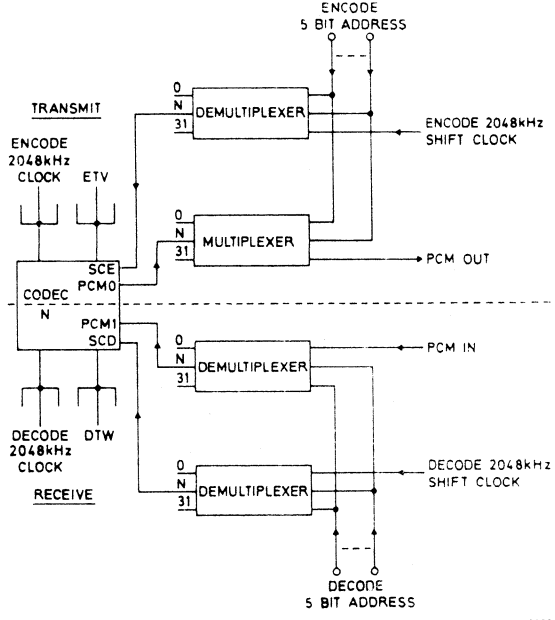

6029

ZNPCM1

(c) Switching Applications

The ZNPCM1 can be used in a variety of ways to satisfy switching applications. One technique is to operate directly on the 2,048K bit/s digit stream produced by the circuit arrangement shown in Fig. 3, where each codec has a defined time slot in the bit stream. An alternative technique would be to derive the address applied to the multiplexer and demultiplexer from the contents of a random access memory (RAM) which defines the codec to be used in a given time slot, in an exchange of PCM codewords between the codec and an intermediate store. In this mode of use the codec interface is effectively used as a time switch store.

The circuit shown in Fig 5 can be used without an intermediate store where again the codec addresses are derived from RAM's. The encode address defines the 'source' and the decode address the 'sink' in a given time slot. The decode address may be delayed with respect to the encode address by an integer number of 2,048 kHz clock periods to take account of any small, fixed switching delay.

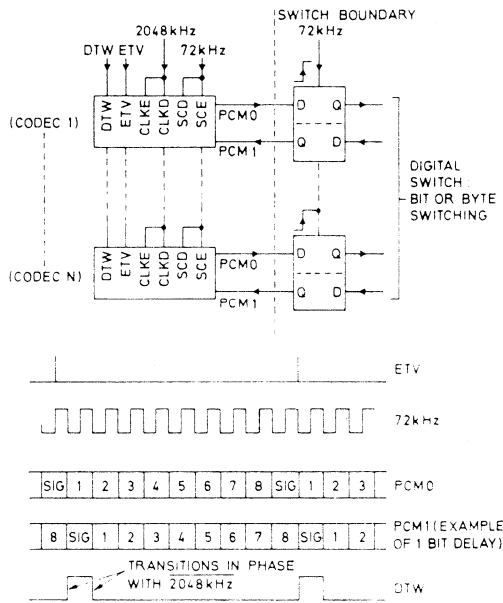

Fig. 6.

Fig. 6 shows an arrangement where the codecs input and output continuously, allowing 9-bits (8 PCM plus 1 signalling) to be exchanged in each 125 μ s sample period. All the codecs may be supplied with common ETV, DTW, 2,048 kHz and 72 kHz waveforms. Each bit is retained in the digital switch using a latch.

The digital switch may be operated using a bit switching arrangement, combined with the extraction and insertion of the signalling bits. Alternatively the bits may be reformatted into bytes and then byte switching performed. If the signalling is handled separately to the pcm codewords then a 64K bit/s rate can be used to and from the codec. This is compatible with using the codecs internal clock mode (MS = 1) in which case the only common timing waveforms required at the codec are the 2,048 kHz clock and the ETV.

(d) Power Switching

Comparisons have previously been made between shared and single channel codecs where these comparisons were reduced to one of power dissipation. Considerable power savings can be made by using the codecs in such a mode that they are only powered-up when required for use.

It is interesting to compare the power dissipation of an eight channel system using in one case eight ZNPCM1s in a power switching mode and, in the other case, one of the more popular time shared codecs which caters for eight channels. One single channel codec dissipates 600 mW and the time shared codec dissipates 1500 mW.

If the channel occupancy is p , then the average power dissipation per channel for the time shared codec is given by

$$W_{TS} = 1 - (1-p)^8 \frac{1500}{8} \text{ mW}$$

This assumes the time shared codec is only powered-up when any of the eight channels are required for use.

The average power dissipation per channel using the single channel codecs is simply given by,

$$W_{SC} = p \cdot 600 \text{ mW}$$

Fig. 7 shows a plot of power dissipation versus channel occupancy ; p for both approaches. The busy period average channel occupancies are likely to be in the range 0.2 to 0.15, clearly the lower end of the curves. Taking a figure of $p = 0.06$, for example, then the single channel codec dissipates only 36 mW per channel, approximately 50% less than the time shared codec. As the graph shows even for very busy exchanges given values for p of up to 0.3 shows the ZNPCM1 system to dissipate less power.

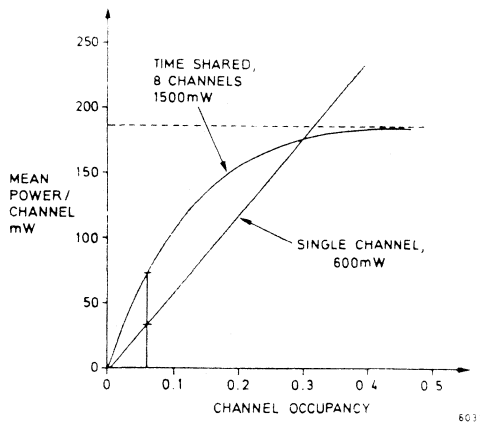
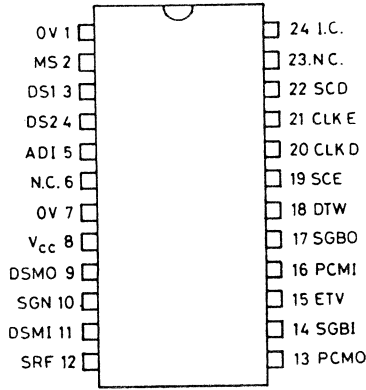

Fig. 7.

ZNPCM1

PIN CONNECTIONS



6234/1

CHIP DIMENSIONS AND LAYOUT

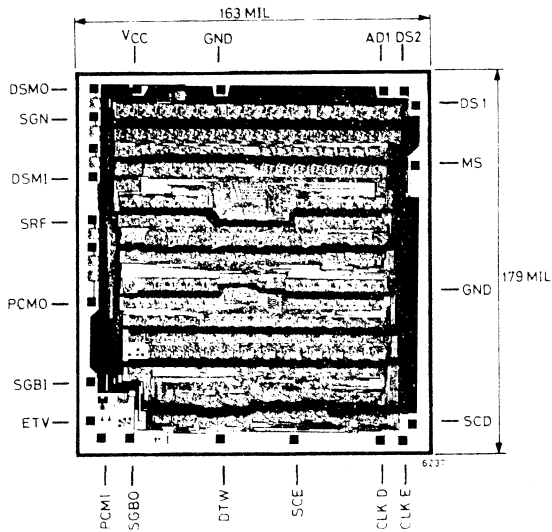



Delta Sigma Modulator/Demodulator I.C.

FEATURES

- Converts analogue input signal into delta sigma modulated (DSM) signal to be used as input for ZNPCM1 Codec I.C.
- Converts DSM signal produced by ZNPCM1 into level defined digital pulse stream for conversion to the analogue equivalent signal using low-pass filter techniques.
- High signal-to-noise ratio.
- Monolithic integrated circuit combining digital and analogue circuitry.
- Single 5V supply.
- 18-lead ceramic or modulated D.I.L. package.

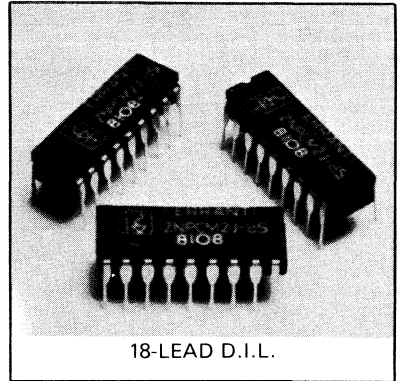

18-LEAD D.I.L.

DESCRIPTION

The ZNPCM2 Delta Sigma Modulator/Demodulator (DSM) Integrated Circuit is designed for use in conjunction with the ZNPCM1 (manufactured by Ferranti Electronics Ltd.) or AY-3-9900 (manufactured by General Instruments Ltd.) Codec I.C.'s as the conversion unit in pulse code modulation communication systems. The ZNPCM2 modulator function converts analogue speech or data signals into a sampled signal having one bit per sample at a high sampling rate. The demodulator function produces an output signal having one of two well defined voltage levels in response to the signal bit per sample input signal. The original signal can then be recovered by low-pass filter techniques.

The ZNPCM2 provides excellent signal-to-noise ratio as a result of innovative circuit techniques developed at the British Post Office Research Centre. A rectangular input waveform designated as a spectral redistribution function (SRF) is provided and this modifies the quantisation noise spectrum, moving the noise components to higher frequencies. By varying the amplitude and phase of the SRF waveform, the net effects on the PCB outputs from the Codec system can be made to be ZERO if the SRF is sampled synchronously within the system. In addition a complex feedback network is utilised in the DSM circuit to provide increased feedback at low frequency which results in the relative attenuation of low frequency quantisation noise components below 32 kHz.

D.C. alignment to better than 0.01% at low signal amplitudes is achieved at the output by use of a feedback loop minimising both the DSM voltage offset and the digital code offset. This technique makes use of the fact that the PCM code words have a sign and magnitude format and the result eliminates the need for component trimming.

ZNPCM2

Designed using the same technology as the ZNPCM1 Codec I.C., the ZNPCM2 combines both linear and digital circuits on the same monolithic I.C. Packaged in an 18-lead ceramic (ZNPCM2J) or moulded D.I.L. (ZNPCM2E), the device is designed to operate over the the temperature range 0°C to +70°C.

ABSOLUTE MAXIMUM RATINGS

Supply Voltage, V_{CC}	+7 volts
Digital Input Voltage, $V_{IN(D)}$	+5.5 volts
Analogue Input Voltage, $V_{IN(A)}$	4 volts pk-to-pk
Operating Temperature Range	0°C to +70°C
Storage Temperature Range	-65°C to +150°C

RECOMMENDED OPERATING CONDITIONS

Parameter	Min.	Nom.	Max.	Unit
Supply Voltage	4.75	5.0	5.25	V
High-level Output Current, I_{OH} (Digital Outputs)	—	—	-400	μA
Low-level Output Current, I_{OL} (Digital Outputs)	—	—	4	mA
Analogue Output Impedance, Z_{AO}	—	100	—	Ω
Operating Temperature Range, T_{amb}	0	—	70	°C

ELECTRICAL CHARACTERISTICS (over the recommended operating temperature range).

(a) Digital Inputs and Outputs.

Parameter	Test Conditions	Min.	Typ.	Max.	Unit
V_{IH} High-level input voltage		2.3	—	—	V
V_{IL} Low-level input voltage		—	—	0.8	V
V_{OH} High-level output voltage	$V_{CC} = \text{Min.}, I_{OH} = \text{Max.}$	2.4	4	—	V
V_{OL} Low-level output voltage	$V_{CC} = \text{Min.}, I_{OL} = \text{Max.}$	—	—	0.4	V
I_{IH} High-level input current	$V_{CC} = \text{Max.}, V_{IH} = \text{Min.}$	—	0.2	0.4	mA
I_{IL} Low-level input current	$V_{CC} = \text{Max.}, V_{IL} = \text{Min.}$	—	—	10	μA
I_{CC} Supply current	$V_{CC} = \text{Max.}$	—	24	—	mA
f Operating frequency		—	2,048	—	kHz
t_r & t_f Rise and fall time	0.4V - 3.0V transition	5	—	40	ns
t_{pd} Propagation delay	Clock ϕ_E or ϕ_D to DSM output 2.5V level	—	40	60	ns
t_{pw} Pulse width	Between 1.5V levels	200	—	—	ns

(b) Analogue Input and Output.

Parameter	Test Conditions	Min.	Typ.	Max.	Unit
V_{IN}	Analogue Input Voltage for 0dBm0	—	1.4	—	V
Z_{IN}	Analogue Input Impedance	Measured at 1kHz	80	100	k Ω
V_C	D.C. Voltage across C_{11}	$V_{CC} = \text{Max.}$	—	± 3.0	mV

DSM CODEC INTERFACE

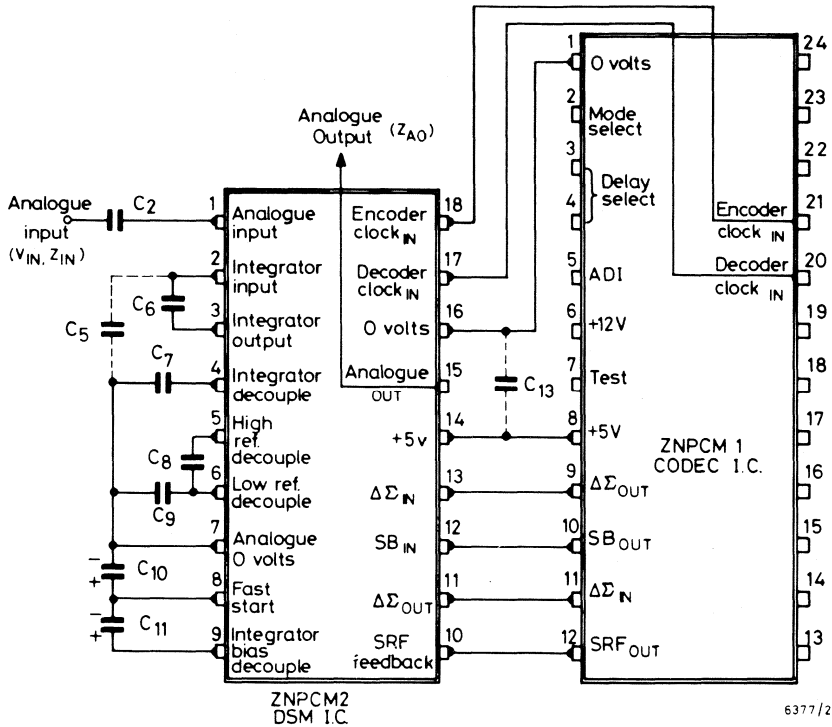

NOTES

- The external high frequency decoupling between pins 5, 6 and 7 should be of minimal impedance (i.e. in the range of 1 to 20 MHz). Low loss capacitors connected via minimal conductor path lengths and inductances are required. Suitable capacitors are 0.22 μ F monoblock types. Total connection length and resistance including capacitor leads should be as follows:
 Pins 5 to 6 <10mm and <0.1 Ω
 Pins 6 to 7 <16mm and <0.1 Ω
- Analogue ground pin 7 and digital ground pin 16 must be linked externally. Ideally, this should be their only connection; however, if it is essential that the two 0V systems are connected at a point remote from the ZNPCM2 then pin 16 should remain connected to the analogue ground only.
- Performance of the ZNPCM1 and ZNPCM2 is layout dependent and an optimum layout is shown on page 6. Capacitor C_5 and C_{13} are optional but may improve performance in some instances.

ZNPCM2

PERFORMANCE

The codec combination of the ZNPCM1 and ZNPCM2 meets all the performance requirements of the C.C.I.T.T. recommendation G712 with good safety margins. Using a standard pcm multiplex tester and a spectrum analyser the following performance figures result:

- (1) Idle Channel noise: -70dBm0p (See Fig. 1).
C.C.I.T.T. recommendation = -65dBm0p
- (2) Signal-to-noise ratio and gain level linearity: Figs. 2(a) and 2(b) show the results using a 450 – 550 kHz pseudo-random noise test.
- (3) Intermodulation distortion: measured products are at least 10dB and on average 18dB better than C.C.I.T.T. recommendations.

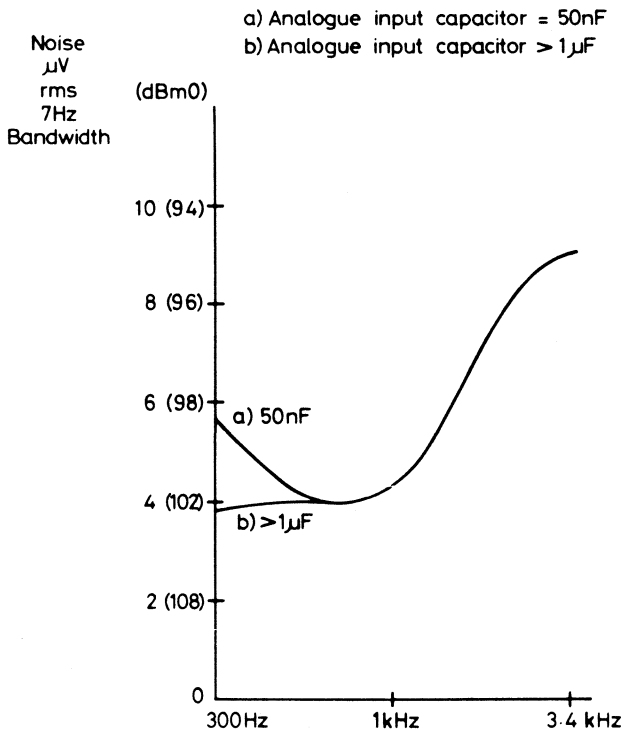

6406

Fig. 1. Idle Channel Noise Spectrum

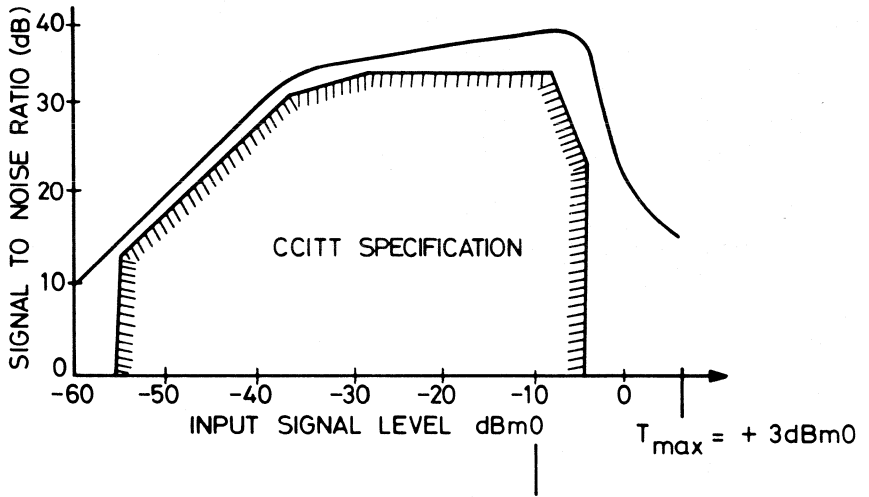
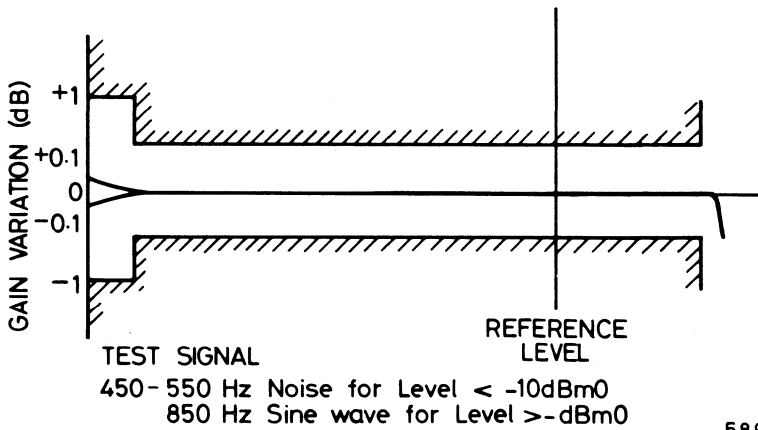

Fig. 2(a). Signal to Noise Ratio 'A Law'



5899/2

Fig. 2(b). Gain to Signal Level 'A Law'

ZNPCM2

BASIC SYSTEM BOARD FOR ANALOGUE TO ANALOGUE PERFORMANCE EVALUATION

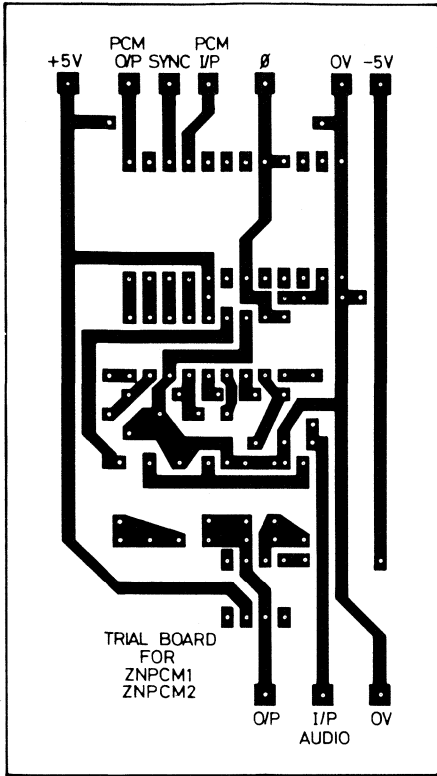

6410

P.C. BOARD

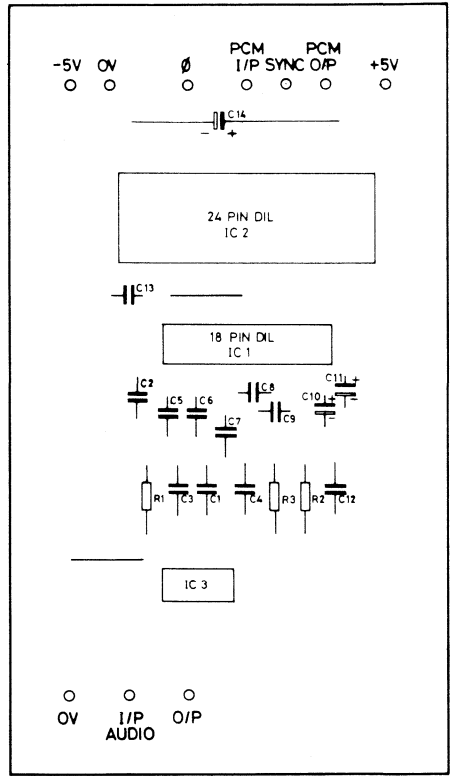

6411/2

COMPONENT LAYOUT

ACTUAL SIZE

ZNPCM1 & ZNPCM2 TRIAL UNIT

Component List (Tolerances $\pm 20\%$ unless otherwise shown)

IC1	ZNPCM2	C6	47 pF $\pm 5\%$
IC2	ZNPCM1	C7	4.7 nF $\pm 5\%$
IC3	741 or Amp	C8	0.22 μ F
R1	91k0 2%	C9	0.22 μ F
R2	91k0 2%	C10	10 μ F, 16V Tantalum Electrolytic
R3	100k0	C11	10 μ F, 16V Tantalum Electrolytic
C1	0.022 μ F	C12	47 nF
C2	47 nF	C13	0.1 μ F Ceramic
C3	100 pF $\pm 2\%$	C14	6.8 μ F, 10V Electrolytic
C4	1 nF $\pm 2\%$		
C5	10 pF		

ZNPCM2

SCHEMATIC

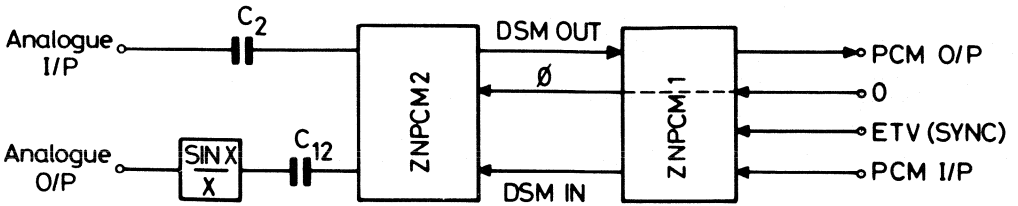

6440

Single Channel Codec System Operating in Internal Mode (PCM at 64K bits/sec. without ADI).

Performance of the ZNPCM1/2 may be simply evaluated by linking PCM O/P to PCM I/P and comparing Analogue O/P to Analogue I/P. No ETV (Sync) signal is required for this.

For a more comprehensive evaluation two boards are required connected on the configuration shown,

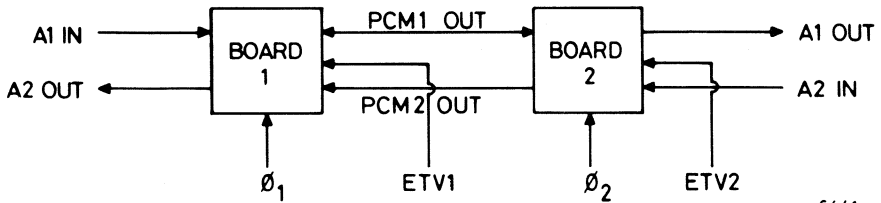

6441

ϕ_1 and ϕ_2 must be the same frequency and ETV1 and ETV2 can be common or up to 30 clock periods displaced.

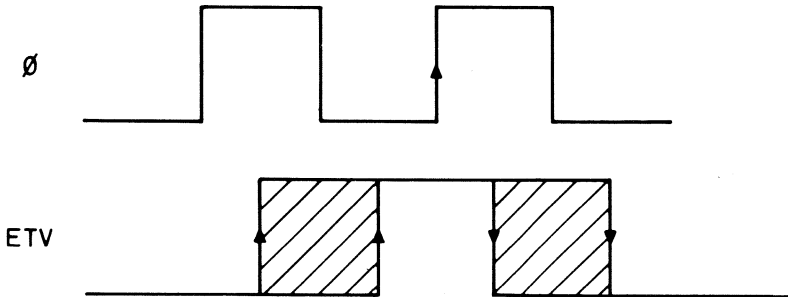

6442

WAVEFORMS SHOWING ETV TOLERANCE

ZNPCM2

PINNING CONFIGURATION

- Pin 1 Analogue Input
- Pin 2 Integrator Input
- Pin 3 Integrator Output
- Pin 4 Integrator Feedback Decouple
- Pin 5 High-level Reference Voltage Decouple
- Pin 6 Low-level Reference Voltage Decouple
- Pin 7 Analogue 0V
- Pin 8 Centre-level Reference Voltage Decouple
- Pin 9 D.C. Feedback Decouple
- Pin 10 SRF Input
- Pin 11 DSM Output
- Pin 12 Sign Bit Input
- Pin 13 DSM Input
- Pin 14 V_{CC}
- Pin 15 Unfiltered Analogue Output
- Pin 16 Digital 0V
- Pin 17 Decoder Clock
- Pin 18 Encoder Clock

5. Quality Assurance Program

Contents

	page
Ferranti Quality Assurance Program	5-3
Processing	5-3
Assembly	5-3
Screening	5-6
Testing	5-6
Quality Assurance	5-6
Acceptable Quality Levels	5-7

5. QUALITY ASSURANCE PROGRAMME

The quality control procedures at Ferranti Electronics Limited are based on British Standard 9000, the relevant documents being :

BS 9002 : Qualified products list for electronic components of assessed quality (including list of approved firms).

BS 9400 : Integrated electronic circuits and micro-assemblies of assessed quality.

BS 9450 : Custom-built integrated circuits of assessed quality.

BS 6001 : Sampling procedures and tables for inspection by attributes.

The quality emphasis at Ferranti is on process control (as indicated by the use of many monitors and audits) in addition to gate inspections. This philosophy is consistent with building in quality and reliability rather than attempting solely to screen for it.

There are five basic stages in the manufacture of Ferranti data converters, as shown below :

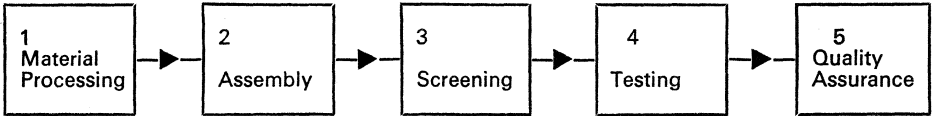

Each of these stages has associated with it a number of quality control checks to ensure that components will meet the standards required by the most stringent environments encountered in the field of electronics.

5.1 Processing

The technology used to fabricate the Ferranti range of data converters is a five mask bipolar process (see publication ref. ESA 480673). This process is used to manufacture the whole range of Ferranti LSI products, but is especially suited to converter products since it allows analogue and digital circuits to be fabricated on the same chip, with good yields and high packing densities. The process has full BS 9450 capability approval and is the first bipolar process in the U.K. to receive such approval.

5.2 Assembly

Ferranti data converters are available in either moulded or hermetically sealed ceramic dual in-line (DIL) packages (though certain types are available only in ceramic package). The assembly flow-charts for both types of package are shown in Table 1. All products are manufactured by the same routes and using the same techniques as BS 9000 approved products.

Q A Programme

PLASTIC Wafer

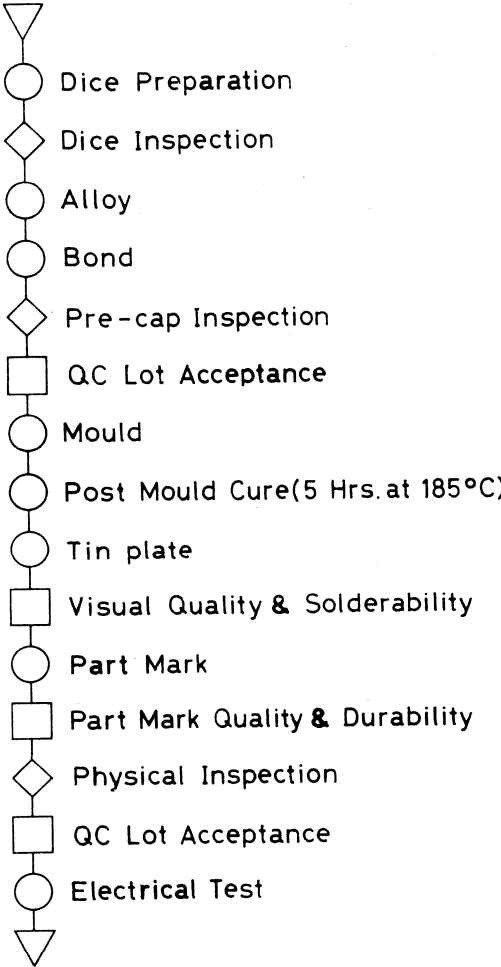

Warehouse

CERAMIC Wafer

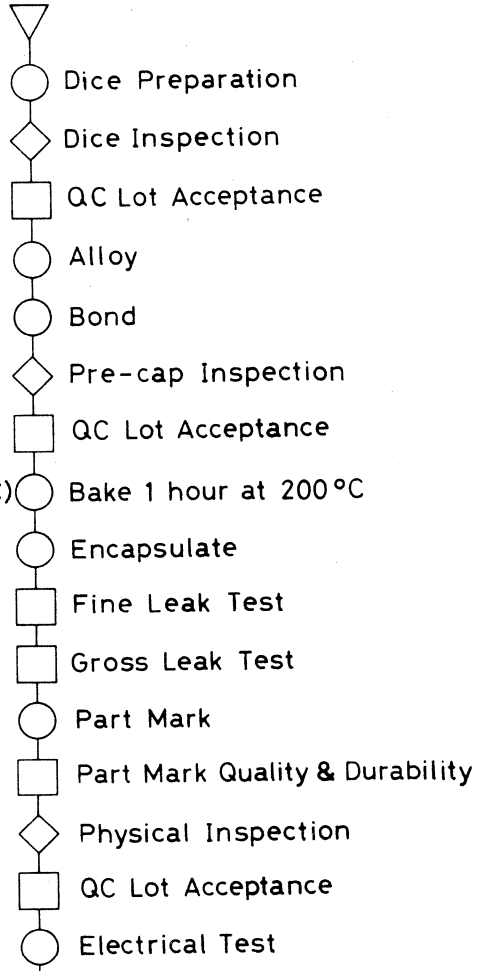

Warehouse

Key: ○ Product Process ◇ 100% Inspection □ Sampling

6083

Q A Programme

TABLE 2

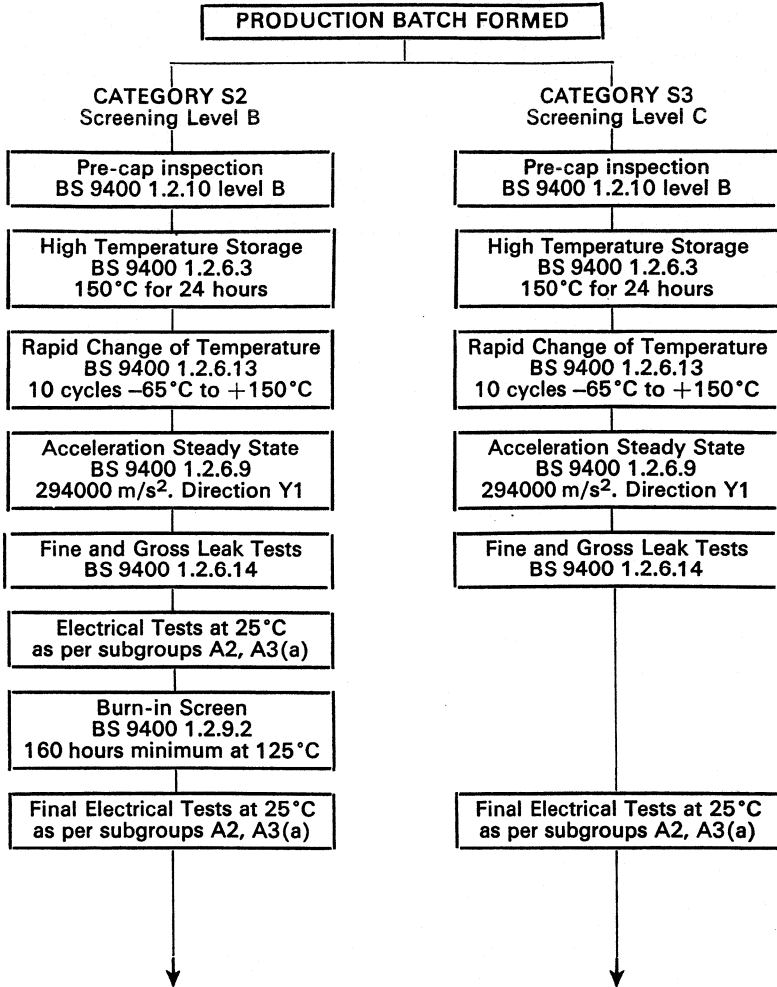

Q A Programme

5.3 Screening

In addition to the standard manufacturing cycle, optional screening procedures are available to produce high-reliability products. A full breakdown of the options available, related to their BS 9400 procedures, is shown in Table 2.

5.4 Testing

On completion of assembly all devices are subjected to 100% functional and d.c. testing in addition to either an S4, 2.5% sample or 100% check on a.c. characteristics depending on device type. The d.c. tests are inset to tighter limits than those shown on the data sheet in order to ensure that the device will function within the specified conditions over its full operating temperature range.

In addition to the 100% test already described, devices manufactured to commercial specifications also undergo sample tests to the AQLs in Table 3, including the temperature extreme tests mentioned above.

TABLE 3

Inspected Parameter	Inspection Level	AQL
Visual & Mechanical including major external workmanship and marking permanency	I	1%
Function	II	0.15%
Major Electrical Parameters at $T_{amb} = 25^{\circ}\text{C}$	II	0.65%
Major Electrical Parameters over operating temperature range	II	2.5%

5.5 Quality Assurance

Despite all the measures taken to ensure that commercial product is of a high standard it is inevitable that certain market sectors will require a higher level of quality assurance. These market sectors are predominantly military and telecommunications orientated.

Wherever devices are supplied to these more stringent QA requirements they are re-routed at the end of the assembly cycle through our QA Bond Department. They are subjected, on a lot-by-lot basis, to a more rigorous examination of their quality using methods laid down in BS 9000 or its equivalent for the specification concerned.

In addition to lot-by-lot testing, long term life testing of product is performed continually. This enables constant monitoring of process stability and any undesirable deviations from the norm are quickly brought to light so that corrective measures may be implemented.

Q A Programme

5.6 Acceptable Quality Levels

As explained earlier the procedures and manufacturing techniques used by Ferranti are consistent with producing an inherently reliable product rather than screening out unreliable product. This is achieved by careful process control combined with numerous gate inspections.

In order for such a system to be effective it is necessary to implement a sampling procedure where the sample size and inspection levels of the various stages are adequate to assure satisfactory quality of the end product whilst remaining cost effective. This can be achieved only after a long history of semiconductor manufacture, which gives an intimate knowledge of the problems likely to arise at each stage of manufacture, and the best methods of inspecting for them.

The sampling procedures used by Ferranti are those outlined in BS 6001. The Acceptable Quality Level (AQL) is the maximum percentage of defective devices that can, for the purposes of inspection, be considered satisfactory as a process average.

The AQL sample size codes and sampling plan used by Ferranti are reproduced in tables 4 and 5.

Q A Programme

TABLE 4
SAMPLE SIZE CODE LETTERS

Lot or batch size	Special inspection levels				General inspection levels		
	S-1	S-2	S-3	S-4	I	II	III
2 to 8	A	A	A	A	A	A	B
9 to 15	A	A	A	A	A	B	C
16 to 25	A	A	B	B	B	C	D
26 to 50	A	B	B	C	C	D	E
51 to 90	B	B	C	C	C	E	F
91 to 150	B	B	C	D	D	F	G
151 to 280	B	C	D	E	E	G	H
281 to 500	B	C	D	E	F	H	J
501 to 1200	C	C	E	F	G	J	K
1201 to 3200	C	D	E	G	H	K	L
3201 to 10000	C	D	F	G	J	L	M
10001 to 35000	C	D	F	H	K	M	N
35001 to 150000	D	E	G	J	L	N	P
150001 to 500000	D	E	G	J	M	P	Q
500001 and over	D	E	H	K	N	Q	R

Q A Programme - TABLE 4

Sample size code letter	Acceptable Quality Levels (normal inspection)																																									
	0.010		0.015		0.025		0.040		0.065		1.0		1.5		2.5		4.0		6.5		10		15		25		40		65		100		150		250		400		650		1000	
	Ac	Re	Ac	Re	Ac	Re	Ac	Re	Ac	Re	Ac	Re	Ac	Re	Ac	Re	Ac	Re	Ac	Re	Ac	Re	Ac	Re	Ac	Re	Ac	Re	Ac	Re	Ac	Re	Ac	Re	Ac	Re	Ac	Re				
A	0	1	0	1	0	1	0	1	0	1	0	1	0	1	0	1	0	1	0	1	0	1	0	1	0	1	0	1	0	1	0	1	0	1	0	1	0	1	0	1		
B	0	1	0	1	0	1	0	1	0	1	0	1	0	1	0	1	0	1	0	1	0	1	0	1	0	1	0	1	0	1	0	1	0	1	0	1	0	1	0	1		
C	0	1	0	1	0	1	0	1	0	1	0	1	0	1	0	1	0	1	0	1	0	1	0	1	0	1	0	1	0	1	0	1	0	1	0	1	0	1	0	1		
D	0	1	0	1	0	1	0	1	0	1	0	1	0	1	0	1	0	1	0	1	0	1	0	1	0	1	0	1	0	1	0	1	0	1	0	1	0	1	0	1		
E	0	1	0	1	0	1	0	1	0	1	0	1	0	1	0	1	0	1	0	1	0	1	0	1	0	1	0	1	0	1	0	1	0	1	0	1	0	1	0	1		
F	0	1	0	1	0	1	0	1	0	1	0	1	0	1	0	1	0	1	0	1	0	1	0	1	0	1	0	1	0	1	0	1	0	1	0	1	0	1	0	1		
G	0	1	0	1	0	1	0	1	0	1	0	1	0	1	0	1	0	1	0	1	0	1	0	1	0	1	0	1	0	1	0	1	0	1	0	1	0	1	0	1		
H	0	1	0	1	0	1	0	1	0	1	0	1	0	1	0	1	0	1	0	1	0	1	0	1	0	1	0	1	0	1	0	1	0	1	0	1	0	1	0	1		
I	0	1	0	1	0	1	0	1	0	1	0	1	0	1	0	1	0	1	0	1	0	1	0	1	0	1	0	1	0	1	0	1	0	1	0	1	0	1	0	1		
J	0	1	0	1	0	1	0	1	0	1	0	1	0	1	0	1	0	1	0	1	0	1	0	1	0	1	0	1	0	1	0	1	0	1	0	1	0	1	0	1		
K	0	1	0	1	0	1	0	1	0	1	0	1	0	1	0	1	0	1	0	1	0	1	0	1	0	1	0	1	0	1	0	1	0	1	0	1	0	1	0	1		
L	0	1	0	1	0	1	0	1	0	1	0	1	0	1	0	1	0	1	0	1	0	1	0	1	0	1	0	1	0	1	0	1	0	1	0	1	0	1	0	1		
M	0	1	0	1	0	1	0	1	0	1	0	1	0	1	0	1	0	1	0	1	0	1	0	1	0	1	0	1	0	1	0	1	0	1	0	1	0	1	0	1		
N	0	1	0	1	0	1	0	1	0	1	0	1	0	1	0	1	0	1	0	1	0	1	0	1	0	1	0	1	0	1	0	1	0	1	0	1	0	1	0	1		
P	0	1	0	1	0	1	0	1	0	1	0	1	0	1	0	1	0	1	0	1	0	1	0	1	0	1	0	1	0	1	0	1	0	1	0	1	0	1	0	1		
Q	0	1	0	1	0	1	0	1	0	1	0	1	0	1	0	1	0	1	0	1	0	1	0	1	0	1	0	1	0	1	0	1	0	1	0	1	0	1	0	1		
R	0	1	0	1	0	1	0	1	0	1	0	1	0	1	0	1	0	1	0	1	0	1	0	1	0	1	0	1	0	1	0	1	0	1	0	1	0	1	0	1		

- Use first sampling plan below arrow. If sample size equals, or exceeds, lot or batch size, do 100 percent inspection.
- Use first sampling plan above arrow.
- Ac Acceptance number.
- Re Rejection number.

6. Package Details

Contents

	page
Package Drawings and Outlines	6-3

6. Package Details

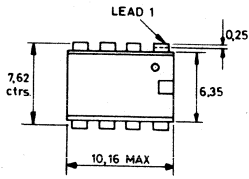

4882 MD/2

8 LEAD MOULDED DIL

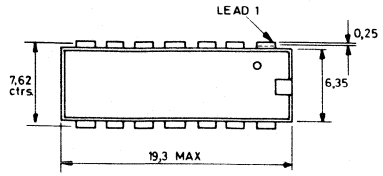

4680 MD/2

14 LEAD MOULDED DIL

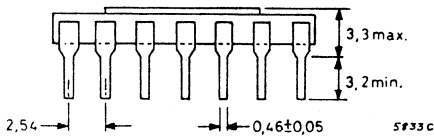
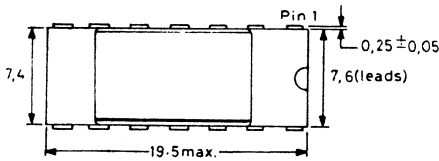
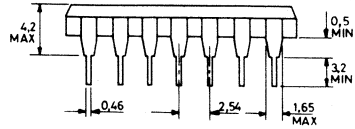
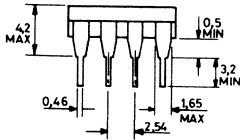

5733 c

14 LEAD CERAMIC DIL
(SIDE-BRAZED)

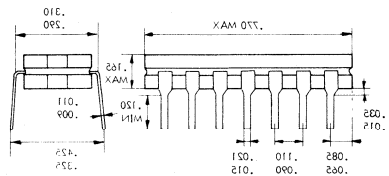

14 LEAD CERAMIC DIL
(CERDIP)

Package Details

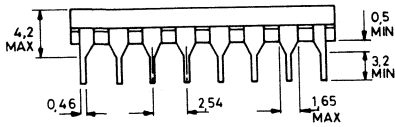
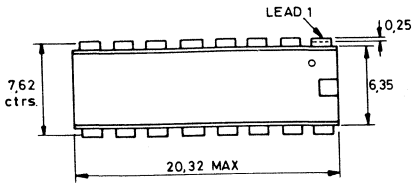

4681 MD/1

16 LEAD MOULDED DIL

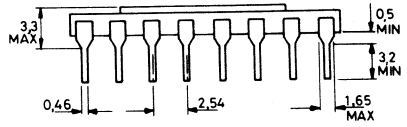
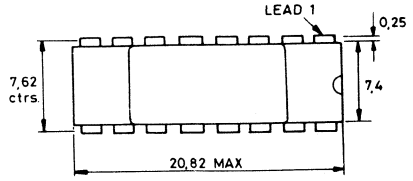

5365 C/1

16 LEAD CERAMIC DIL
(SIDE-BRAZED)

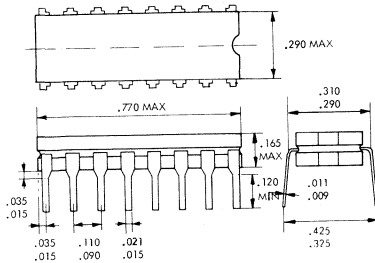

16 LEAD CERAMIC DIL
(CERDIP)

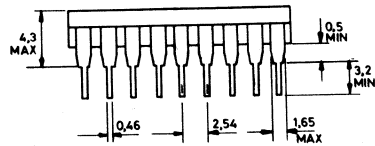
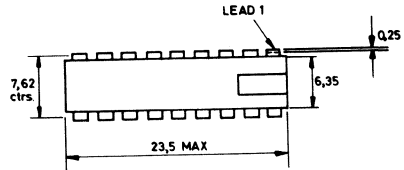

5455/2MD

18 LEAD MOULDED DIL

Package Details

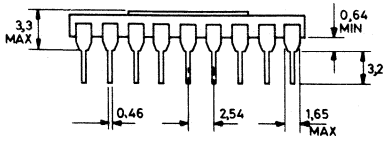
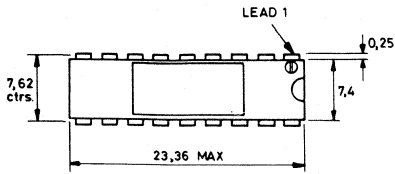

5499/1

18 LEAD CERAMIC DIL
(SIDE-BRAZED)

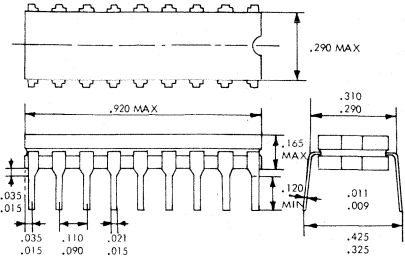

18 LEAD CERAMIC DIL
(CERDIP)

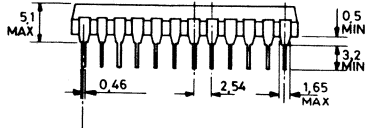
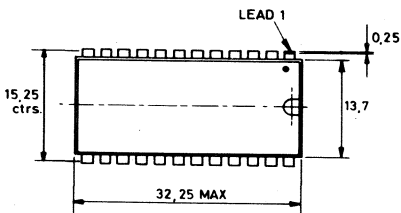

4117/2MD

24 LEAD MOULDED DIL

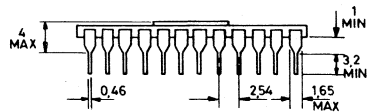
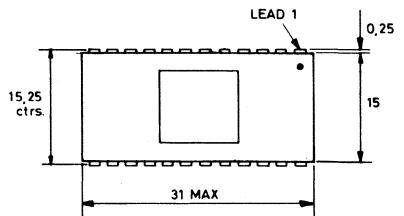

5476/1

24 LEAD CERAMIC DIL

Package Details

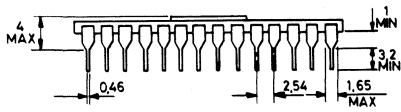
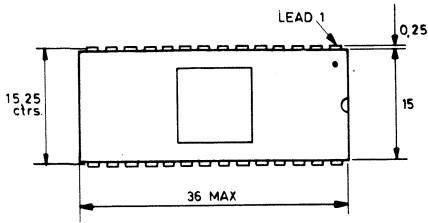

5457/3

28 LEAD CERAMIC DIL

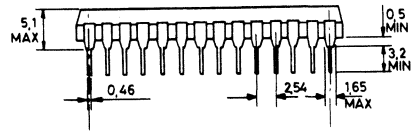
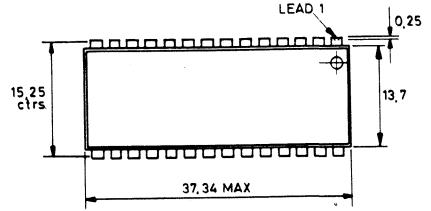

4116 MD/2

28 LEAD MOULDED DIL

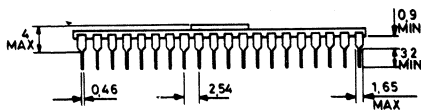
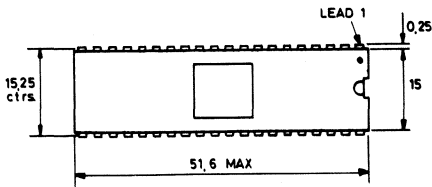

5458/1

40 LEAD CERAMIC DIL

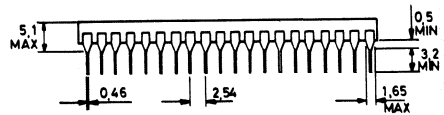
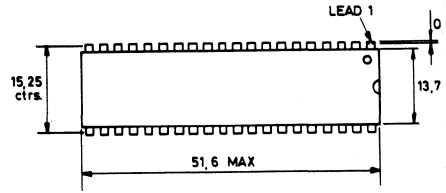

5454 MD/1

40 LEAD MOULDED DIL

Package Details

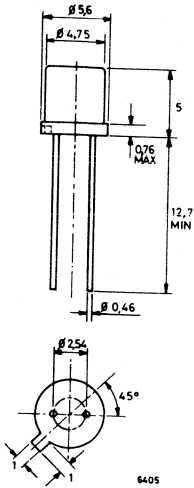

TO-18 (2 Lead)

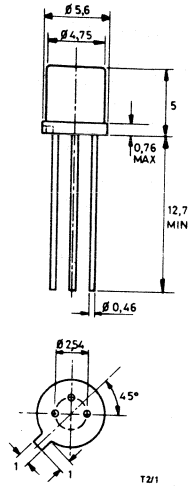

TO-18

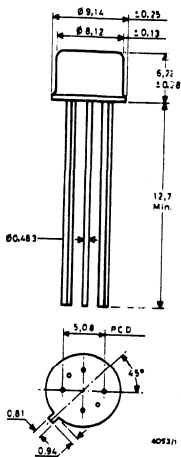

TO-39 (6 Lead)

7. Application Notes

Contents

	page
Applications of the ZN425 8 bit A/D-D/A-Converter	7-3
Microprocessor Interfacing using the ZN427/ZN428 Data Converters	7-33
Direct Bus Interfacing using the ZN427/ZN428 Data Converters	7-59
Microprocessor Interfacing using the ZN432 10 bit Data Converter	7-69
A Serial Interface for the ZN427 A/D Converter	7-79
A Single Channel Codec (ZN PCM1/ZN PCM2)	7-87

Applications of the ZN425 8 bit A-D/D-A Converter

CONTENTS

1. **Introduction**
 - 1.1 Definitions
2. **D-A and A-D Converter Systems**
 - 2.1 8 bit D-A and Calibration Procedure
 - 2.2 8-bit A-D and Calibration Procedure
 - 2.3 Bipolar Operation
 - 2.4 Applications
3. **Ramp Generation**
 - 3.1 Continuous
 - 3.2 One Shot
 - 3.3 Weighing System and Auto Zero
 - 3.4 Peak Detect
 - 3.5 Channel Selector
 - 3.6 Bargraph Display Drive System
 - 3.7 Up Down or Tracking
4. **Multiply/Divide**
 - 4.1 Multiplier
 - 4.2 Variable Frequency Divider
 - 4.3 Voltage Controlled Oscillator
5. **Function Generation**
 - 5.1 Inverse Scaler
 - 5.2 Parabola
 - 5.3 Log Approximation
6. **Conclusions**

1. INTRODUCTION

Digital to analogue, (D-A), and analogue to digital, (A-D), conversion is a specialised field of electronics. It is useful to consider first the general principles of such conversion techniques, and definitions commonly used in the general field of A-D and D-A conversion.

The discussion is limited to 8-bit converters of a type similar to the ZN425E, illustrated in Figure 1a.

Digital information, fed in to the converter, normally as parallel bits, generates an analogue output corresponding to the value of the binary coded number entered at the input. Ignoring errors for the moment, and assuming that the analogue output is a voltage, the output can be expressed as:

$$V_{out} = V_{full\ scale} \times \frac{\text{Binary Input}}{\text{Full scale binary input}}$$

which, in the case of the ZN425E, is

$$V_{out} = V_{REF} \times \frac{\text{Binary Input}}{256}$$

The voltage output is obtained using a resistive ladder network shown in Figure 1b. Switches connect resistors within the network either to the reference voltage or to the ground line according to the state of the binary inputs controlling each particular switch.

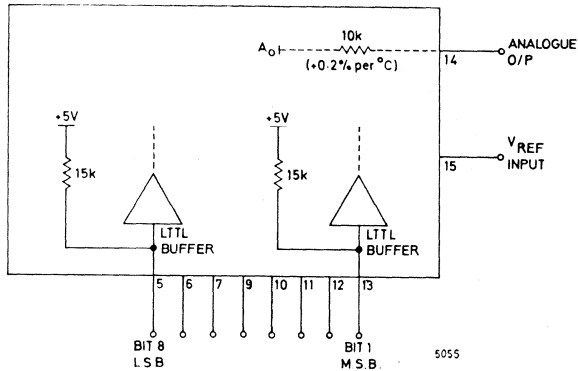

Fig. 1a Basic 8 bit D to A converter

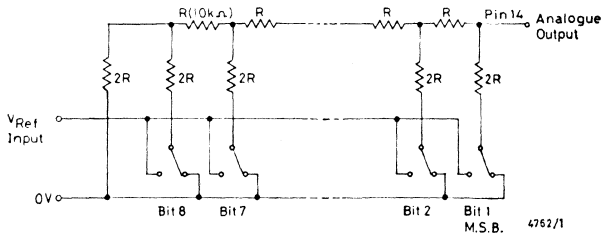

Fig. 1b The R-2R ladder network

The block diagram of the ZN425E circuit is reproduced in Figure 2.

The integrated circuit is fully monolithic. It contains a resistive ladder network, a logic input select switch, voltage switches, an internal reference and a counter. The D-A reference may be connected to the internally generated reference or to an external application. The inclusion of a counter within the circuit considerably extends its application. A 'staircase' waveform can be very simply generated at the analogue output by feeding a train of clock pulses into the counter.

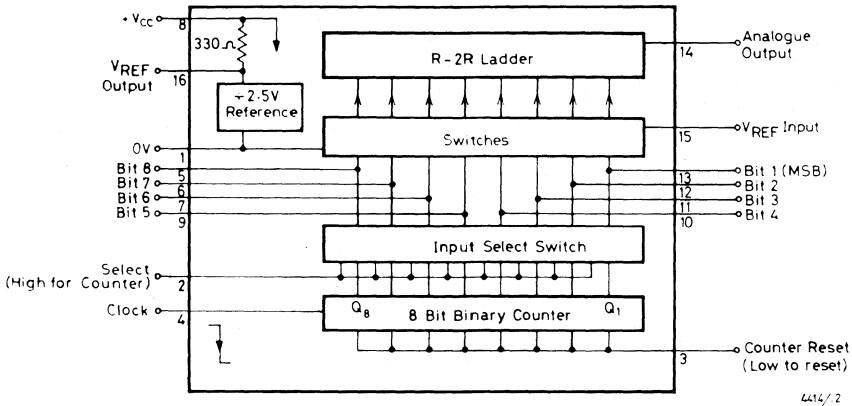

Fig. 2 Block diagram of ZN425E

The ZN425E system operation is outlined in Figure 3. The counter may be clocked by negative going inputs and reset by applying a '0' level to the reset pin.

The digital inputs to the converter may be obtained either from an external source when the 'logic select' pin is at logical '0', or from the counter when it is set to logical '1'. In the latter case the state of the counter appears at the digital input terminals as '0' or '1' levels on open collectors with 15 kΩ pull up resistors. In the D-A mode the digital input terminals may be considered as low power TTL inputs.

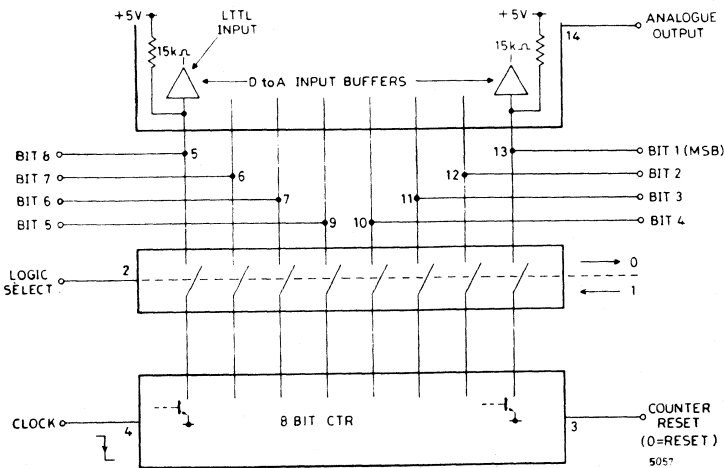

Fig. 3 Outline ZN425E operation

1.1 Definitions

Various terms commonly used when discussing D-A and A-D converter operation are defined below.

Resolution

The resolution is determined by the number of digital inputs, i.e. an 8 bit DAC, (digital to analogue converter), is said to have 8 bit resolution. No particular level of accuracy is implied.

Staircase/Ramp

As the binary code is increased step by step, the analogue output also increases in discrete steps. If the input code increases at a constant rate the resulting output will be a staircase

Since the number of discrete steps is normally large, e.g. 255 for 8 bits, the staircase is frequently termed a ramp, though this is not strictly accurate.

Monotonicity

A DAC is said to be monotonic if an increase in the applied binary coded digital number always produces an increase in the analogue output. Waveforms produced by a D-A 'staircase' generator illustrated in Figure 4a shows the effect of non monotonicity.

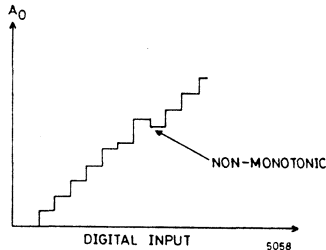

Fig. 4a Non-monotonicity

Ideal DAC Output

The ideal DAC output of a staircase generator is shown in Figure 4b.

The output is defined as a set of points on a straight line between zero and full scale. For an ideal 8-bit DAC:

$$V_{out} = \frac{n}{2^8 - 1} \times V_{FS}$$

$$= \frac{n}{255} \times V_{FS}$$

and

$$V_{FS} = \frac{255}{256} \times V_{REFInput}$$

∴

$$V_{out} = \frac{n}{256} \times V_{REFInput}$$

where 'n' is the number represented by the digital input.

For example $01101100 = 2^6 + 2^5 + 2^3 + 2^2$
 $= 108$

gives an output

$$V_{out} = \frac{108}{256} \times V_{FS}$$

$$= \frac{108}{256} \times V_{REFInput}$$

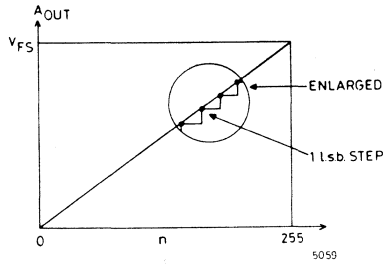

Fig. 4b Ideal DAC output

Linearity Error

A DAC may deviate from the ideal as shown in Figure 4c. The error is usually specified as a maximum deviation of the analogue output, from the ideal output, as a fraction of the 'Least Significant Bit'. The ZN425E has a linearity better than $\pm \frac{1}{2} \text{LSB}$, and

$$\frac{1}{2} \text{LSB} = \frac{1}{2} \times \frac{V_{FS}}{255}$$

Relative Accuracy

The error expressed as a percentage of the full scale voltage, V_{FS} , is termed the relative accuracy.

The ZN425E, an 8-bit converter with $\pm \frac{1}{2} \text{LSB}$ linearity, has a relative accuracy of $\frac{1}{510} \times 100\%$, i.e. approximately 0.2% accuracy.

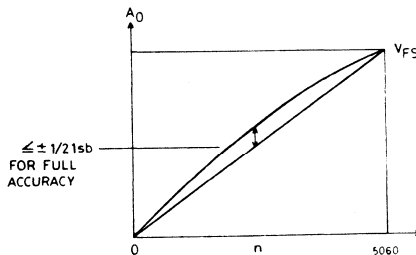

Fig. 4c Error definition

2. D-A and A-D CONVERTER SYSTEMS

2.1 8 bit D-A and Calibration Procedure

The ZN425E gives an analogue voltage output directly from pin 14, so that the usual current to voltage converting amplifier is not required. However, in order to buffer the resistive ladder output impedance, to remove the offset voltage and to calibrate the converter a buffer amplifier is necessary. Figures 5a and 5b show a typical scheme with either the ZN424P or ZLD741CP as the buffer amplifier. The internal voltage reference source (V_{REFout}) is used, and to minimise temperature drift the source resistance to the inverting input of the buffer amplifier should be approximately 6 k Ω . Calibration procedure is as follows :

- (i) Set all bits to LOW and adjust R2 until $V_{out} = 0.000V$
- (ii) Set all bits to HIGH and adjust R1 until $V_{out} = \text{nominal full scale reading} - \text{LSB}$.
- (iii) Repeat (i) and (ii).

e.g. Set F.S.R. to $+3.840V - 1 \text{ LSB} = 3.825V$.

$$(1 \text{ LSB} = \frac{3.84}{256} = 15 \text{ mV})$$

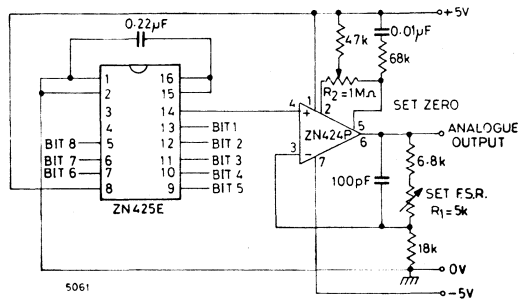

Fig. 5a 8 bit DAC using ZN424P

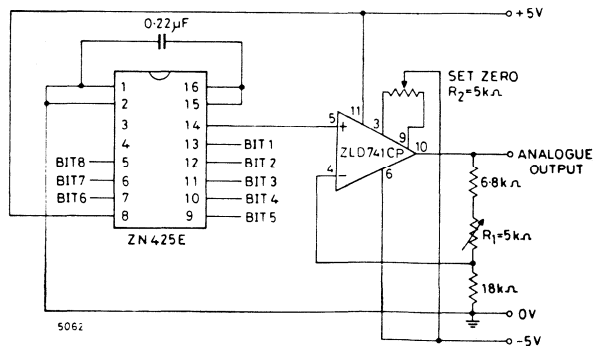

Fig. 5b 8 bit DAC using ZLD741CP

2.2 8 bit A-D and Calibration Procedure

Figure 6 shows the ZN425E in a counter type ADC which comprises a comparator and a latch and requires an external clock. Upon application of a convert command pulse (15 μ s minimum) the counter is set to zero and at the same time the state of the latch is altered.

The gate is opened, enabling clock pulses to be fed to the counter input (Pin 4) of the ZN425E. The analogue output of the ZN425E begins to ramp up until its amplitude equals that of the analogue voltage at the non-inverting input of the comparator. At this point the comparator changes state, altering the latch to its initial resting state, thus inhibiting further clock pulses. Hence the digital number stored in the respective bits of the ZN425E is a true representation of the analogue input voltage. The diode is included so that when the comparator changes state, its output is effectively clamped at zero (LOW).

Operating clock frequencies can be as high as 400 kHz. Improved results may be obtained by using narrow clock pulses to avoid the trailing edge affecting ramp settling. At frequencies above 100 kHz a faster comparator than the ZN424 should be used for optimum linearity around zero.

The conversion time is dependent upon the analogue input and for full scale reading (F.S.R.) is given by the clock period multiplied by the number of counts.

$$\text{If } F_{\text{Clock}} = 256 \text{ kHz,}$$

$$T_{\text{Convert}} = \frac{2^8}{256 \times 10^3} \text{ seconds} = 1 \text{ ms}$$

The calibration procedure is as follows:

- (i) Apply continuous CONVERT COMMAND PULSES
- (ii) Apply full scale minus $1 \frac{1}{2}$ LSB to analogue input and adjust F.S.R. pot until the converter LSB just switches between 0 and 1 with all other bits at 1.
- (iii) Apply zero + $\frac{1}{2}$ LSB to analogue input and adjust zero pot until the converter LSB just switches between 0 and 1 with all other bits 0.
- (iv) Repeat step (ii)

E.g. Full scale = 4 volts.

$$1 \text{ LSB} = \frac{\text{Full Scale}}{256} = \frac{4 \text{ volts}}{256} = 15.63 \text{ mV}$$

$$\text{Input for zero setting} = \frac{1}{2} \text{ LSB} = 7.82 \text{ mV}$$

$$\text{Input for full scale setting} = 4\text{V} - 1 \frac{1}{2} \text{ LSB} = 3.97656 \text{ volts.}$$

After conversion is complete the analogue input is available from the ZN425E in digital and analogue form and therefore the ADC may be used as a sample and hold with infinite hold time. The convert command is replaced by a sample command.

A peak detect circuit may also be constructed using similar techniques, and is described in section 3.4.

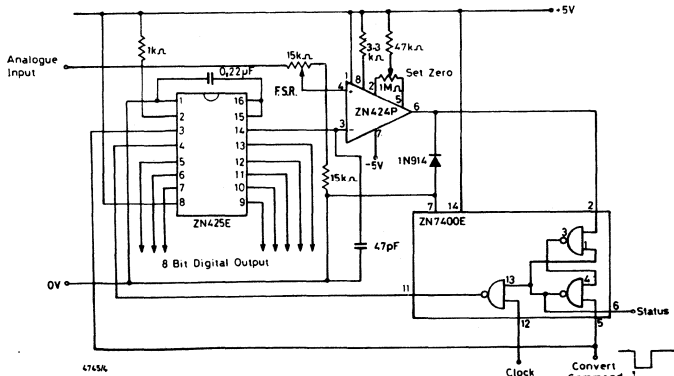

Fig. 6 8 bit Analogue to Digital Converter

2.3 Bipolar Operation

Previous circuits described have entailed the use of a uni-polar buffer amplifier (using ZN424E and ZLD741CP) following a DAC as a means of removing the offset voltage, minimising temperature drift and calibrating the DAC. A natural sequel to this is the derivation of a bi-polar buffer amplifier which fulfils these conditions. This entails buffering the output of a DAC such that the amplified output from the buffer is symmetrical about zero. To effect this, the conditions that have to be satisfied are :

- (i) When the DAC output = $\frac{V_{REF}}{2}$ (digital input = 10000000) then the buffer amplifier output = zero.
- (ii) Gain can be easily selected and suitable resistor values calculated. Actual gain and offset must be capable of fine adjustment.

The circuit of Figure 7a was first devised as a possible solution.

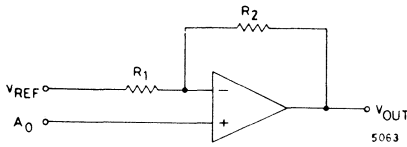

Fig. 7a Bi-polar operation, starting point

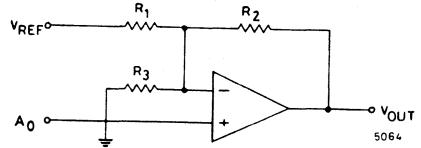

Fig. 7b Bi-polar operation, concept progression

If $F_N = \text{non-inverting feedback return} = \frac{R1}{R1 + R2}$ and $F_I = \text{inverting feedback return} = \frac{R2}{R2}$

Then V_{out} is given by :

$$V_{out} = \frac{A_O}{F_N} - \frac{V_{REF}}{F_I} = A_O \left(\frac{R1 + R2}{R1} \right) - V_{REF} \frac{R2}{R1} \dots \text{equation 1}$$

If $A_O = \frac{V_{REF}}{2}$ and $R1 = R2$ then $V_{out} = 0$ satisfying condition (i).

However Gain (defined as $\frac{V_{out}}{A_O} = \frac{R1 + R2}{R1} = 2$ and condition (ii) would not be satisfied since adjusting $R1$ or $R2$ would upset the gain on offset. To minimise these disadvantages therefore the circuit of Fig. 7b was devised using an additional resistance, with its Thevenin equivalent of Fig. 7c. Using equation 1 then an expression for the output voltage V_{out} can be shown as :

$$V_{out} = A_O \left[1 + \frac{R2 (R1 + R3)}{R1 R3} \right] - V_{REF} \frac{R2}{R1}$$

For $A_O = \frac{V_{REF}}{2}$ (Condition (i)) then $V_{out} = 0$

and $R1 = \frac{R2 R3}{(R2 + R3)}$ i.e. $R1 = \text{parallel combination of } R2 \text{ and } R3.$

Substituting this expression for $R1$

$$\text{then Gain } G = \left[1 + \left(\frac{2R2 + R3}{R3} \right) \right] = \left[2 + \frac{2R2}{R3} \right]$$

If we let say $R2 = \lambda R3$ then $G = 2 (1 + \lambda)$ and $\lambda = \left(\frac{G - 2}{2} \right)$

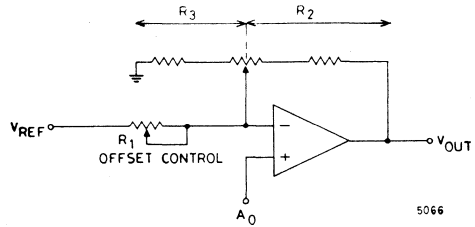
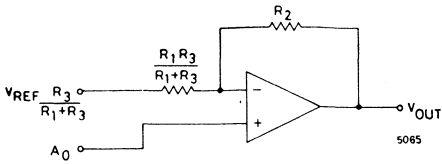

Fig. 7c Thevenin equivalent of Fig. 7b

Fig. 7d Bi-polar operation, control schematic

i.e. $G \geq 2$ from which $R_2 = \left(\frac{G-2}{2}\right) R_3$

And $R_1 = \left(\frac{R_2 R_3}{R_2 + R_3}\right) = \left(\frac{\lambda}{1 + \lambda}\right) R_3 = \left(\frac{G-2}{2}\right) R_3$

Furthermore the buffer amplifier input impedance =

$$\frac{R_1 R_2 R_3}{R_1 R_2 + R_2 R_3 + R_1 R_3} = \left(\frac{G-2}{2G}\right) R_3$$

All the above expressions and relationships form a basis for development of the circuit of Fig. 7d whereby by defining a certain gain (G) all resistor values can be appropriately calculated as illustrated.

e.g. Let $G = 4$, then $R_{in} = \left(\frac{4-2}{8}\right) R_3 = \frac{R_3}{4}$

If $R_{in} = 10 \text{ k}\Omega$ (the value required for minimum offset taking into consideration R_{out} of ZN425E DAC $\approx 10 \text{ k}\Omega$) then $R_3 = 40 \text{ k}\Omega$.

$$R_2 = \left(\frac{G-2}{2}\right) R_3 = \left(\frac{4-2}{2}\right) R_3 = R_3 = 40 \text{ k}\Omega$$

$$\text{And } R_1 = \left(\frac{G-2}{G}\right) R_3 = \left(\frac{4-2}{4}\right) R_3 = \frac{R_3}{2} = 20 \text{ k}\Omega$$

It has been shown that $R_1 = \frac{R_2 R_3}{R_2 + R_3}$. The simplest approximation ensuring this relationship is by using a potentiometer as a gain control.

The finalised circuit is shown in Fig. 8.

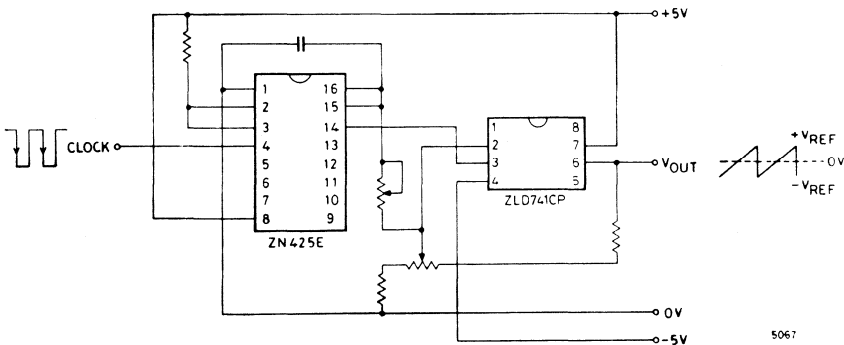

Fig. 8 Bi-polar operation, circuit diagram

2.4 Applications

Applications for the use of the ZN425E in its D-A or A-D mode are those where 8 bit accuracy suffices. This is the majority of transducer applications, particularly as system hierarchy is tending to change with the advent of microprocessors, taking the conversion near to the point of measurement. For example, in data acquisition monitoring say 100 channels, it is feasible and economic to use one D-A per channel and multiplex one A-D per 8 channels using a single microprocessor.

If one reference is required to power several converters, additional source current may be provided by an external parallel resistor from supply to reference providing 1.2 mA per additional converter in excess of three. In this case the additional earth pin current causes an offset due to a pin resistance of around $0.1\ \Omega$

Specific applications of 8 bit A-D are in conjunction with stress or strain gauges, and many temperature applications. 8 bit D-A may be used for driving chart recorders, programmable power supplies and actuators.

3. RAMP GENERATION

The counter in the ZN425E is very convenient for feeding in a clock to generate a staircase. This facility is used in the majority of applications detailed below.

The count rate which may be used to obtain full ramp accuracy, determined by the worst case settling time of $2\ \mu\text{s}$, is 500 kHz, giving a cycling time of around $\frac{1}{2}$ ms. However, the counters are capable of being clocked at up to 5 MHz, though there will be a loss in staircase accuracy at this speed.

3.1 Continuous

This is illustrated by the circuit of Fig. 9 and is simply accomplished in the normal DAC mode by applying clock pulses to the on chip counter (Pin 4) of the ZN425E, which produces a staircase waveform. When the counter is full it returns to its empty state and counting recommences resulting in a continuous ramp.

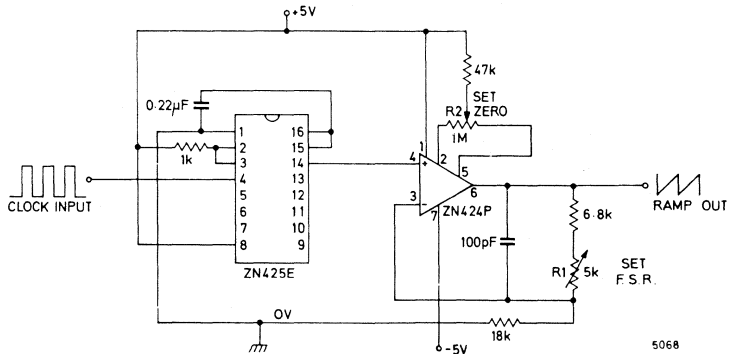

Fig. 9 Precision ramp generator

In order to remove the offset voltage and to calibrate the converter a buffer amplifier is necessary as previously described for the DAC.

The ramp period for 8 bits will be equal to 256 times the clock period, and the maximum amplitude of the ramp from the ZN425E using the internal reference voltage will be $V_{REF_{out}} - 1\ \text{LSB}$. Therefore, the peak ramp amplitude from the buffer will be this value times the amplifier gain, which, with gain adjustment potentiometer set halfway

$$2.5V \times \frac{3}{2} = 3.75V.$$

A duty cycle drive signal is sometimes required from an input voltage generated by a potentiometer, for example, for actuator drives, or general power control. This may be provided as shown in Fig. 10, where the ZN425E provides a continuous ramp, against which the voltage reference is compared using a ZN424P. The output from the comparator then provides the duty cycle signal directly.

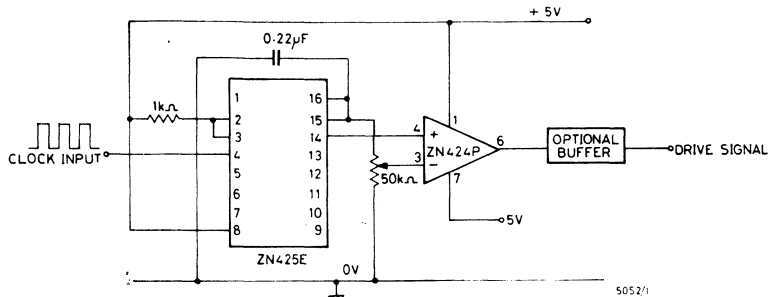

Fig. 10 Duty cycle drive signal

3.2 One Shot

A single one shot ramp can be generated quite simply (Figs 11a and 11b) by using a latch and two capacitors to control the counter reset of a ZN425E DAC. Operation is as follows:

The stationary states of the latch are shown, these being initially determined by the charging times of capacitors C1 and C2 which ensures the counter reset of the ZN425E (Pin 3) is LOW. Upon operating the START button the states of the latch are altered and a HIGH is fed to the counter reset enabling counting of the input clock pulses to commence. The analogue output begins to ramp up until the counter is full at which point the MSB goes LOW altering the latch to its initial resting states. This resets the counter and terminates the ramp. It should be noted that even if the start button is held down at the commencement of the operation, only a one shot ramp results, and not a periodic function.

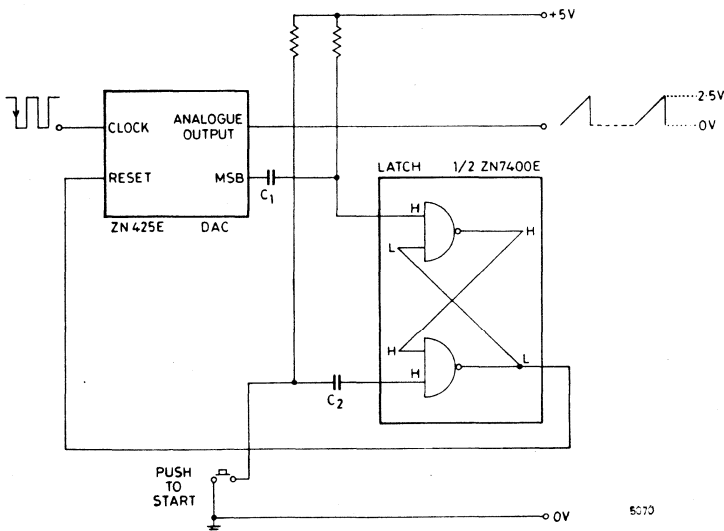

Fig. 11a One shot schematic

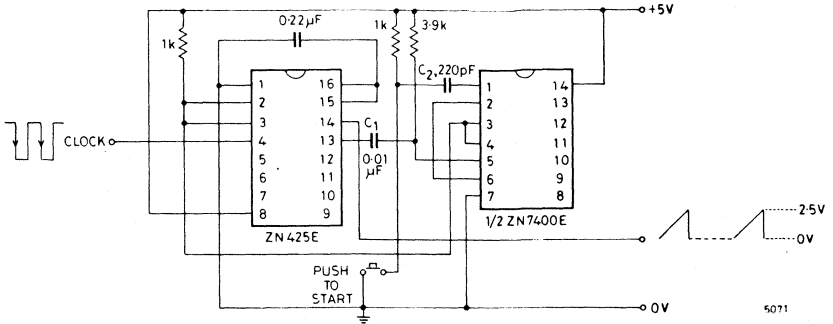

Fig. 11b One shot circuit

A more sophisticated alternative method performing the same function, which replaces capacitors by logic, is outlined in Figs. 11c and 11d. Stationary states of the various logic elements are as indicated. The initial state of the flip-flop is determined by the relative states of the PRESET and CLEAR inputs. Upon switching on the supply the PRESET is held LOW with respect to CLEAR because of the charging time associated with C1 and R1. This results in $Q = \text{HIGH}$, $\bar{Q} = \text{LOW}$, therefore, the counter reset on the ZN425E is LOW.

When the start button is pressed, a pulse from the monostable clears the flip-flop, the counter reset goes HIGH enabling the counting of the input clock pulses to commence. The ZN425E analogue output begins to ramp up until the counter is full, at which point the MSB goes LOW. This is fed to the CLOCK input of the flip-flop which then TOGGLES, reverting to its original state, thereby resetting the counter and terminating the ramp. As with the previous circuit only a one shot ramp will be generated even if the start button is held down.

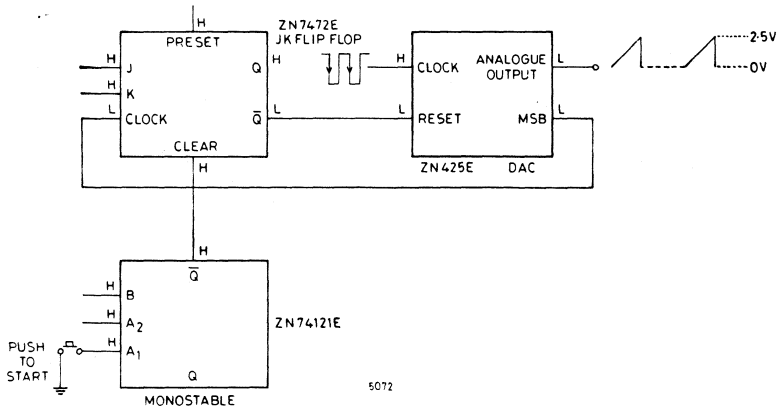

Fig. 11c Alternative one shot schematic

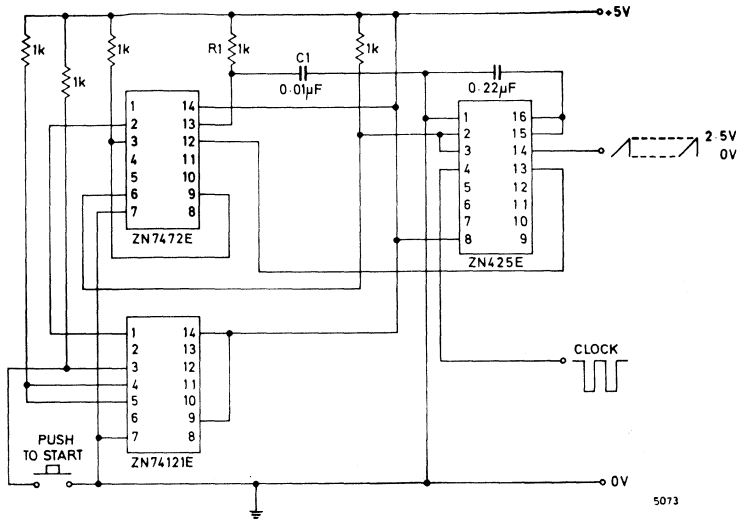

Fig. 11d Alternative one shot circuit

3.3 Weighing System and Auto Zero

The system to be described is intended for either static or on-vehicle load indicating applications and employs integrated circuits from the Ferranti Standard Product range. Variations of the scheme are indicated which increase its range of application. The overall system is shown in the circuit diagrams of Figures 12a to 12e.

The basic measuring function is a $3\frac{1}{2}$ digit DVM using the dual slope analogue to digital converter principle. This displays an analogue input of up to ± 1999 millivolts which is scaled as required. All the DVM digital and control functions are carried out by one C.D.I. integrated circuit from the U.L.A. (Uncommitted Logic Array) range, type ZNA116E.

The DVM input is driven from a separate unity gain summing amplifier which accepts inputs from any number of channels each consisting of transducer and pre-amplifier.

Included in the system is a push button auto-zeroing circuit which automatically sets the output of the summing amplifier to zero. This facility eliminates any small zero errors which may have accumulated in the transducer and pre-amplifier chain or any false zero readings which can appear when on-vehicle systems are operated on uneven ground. For this function the ZN425E 8 bit digital to analogue converter is used. This monolithic integrated circuit also includes an 8 bit binary up-counter and a reference voltage generator and by clocking the counter a voltage ramp of 256 discrete steps is generated. This ramp is level shifted to become symmetrically bipolar with respect to 0V and then applied to the virtual earth of the summing amplifier. This forces the amplifier output through 0V and a comparator circuit detects the 0V condition and inhibits the clock pulses to the counter. The selected ramp output level is therefore held indefinitely unless the auto-zero is switched off when the system reverts to the original zero conditions.

Additional facilities include B.C.D. outputs for data logging purposes and an overload alarm system with warning indication.

The alarm system uses two comparators into which are set two analogue levels, one corresponding to a preset percentage of full load and the other to full load. When the load reaches the first level a 1 Hz square wave output is available and a separate output gives a continuous signal at the second level. These outputs may be wire ORed or used separately to drive visual or audible alarms.

It is not essential for the DVM function to be fully bi-polar in this application because negative readings occur only as small zero errors. A minor modification enables the circuit to display lower accuracy negative readings at the same time eliminating one of the ZN423 reference generators.

Further modification, appropriate for some applications, results in a 3 digit display with a 1 Hz flashing leading zero to indicate a small negative zero.

This approach, using a mix of standard function integrated circuits gives maximum system flexibility. For example, an on-vehicle application may require separate auto-zero indication on a number of axes or an overload alarm indication may require duplication. By adding the appropriate integrated circuits the system can be tailored to suit a range of vehicle requirements with a minimum of chip function redundancy and therefore minimum cost.

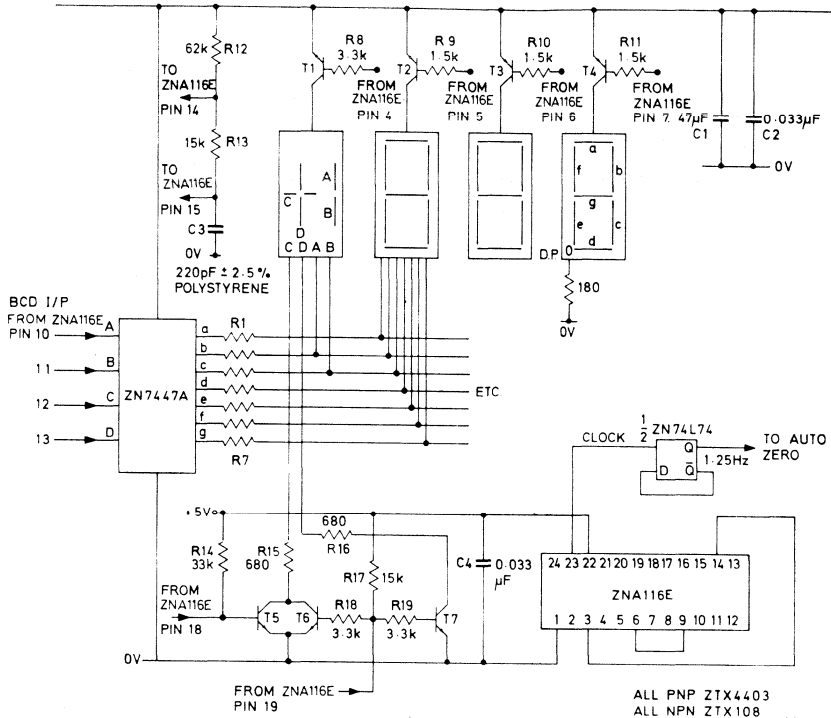

Fig. 12a Display/digital circuit

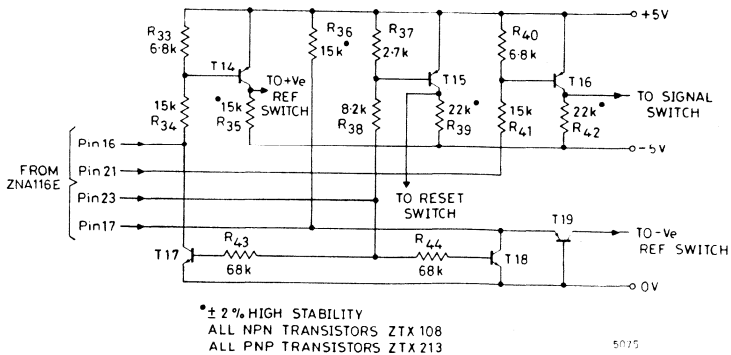
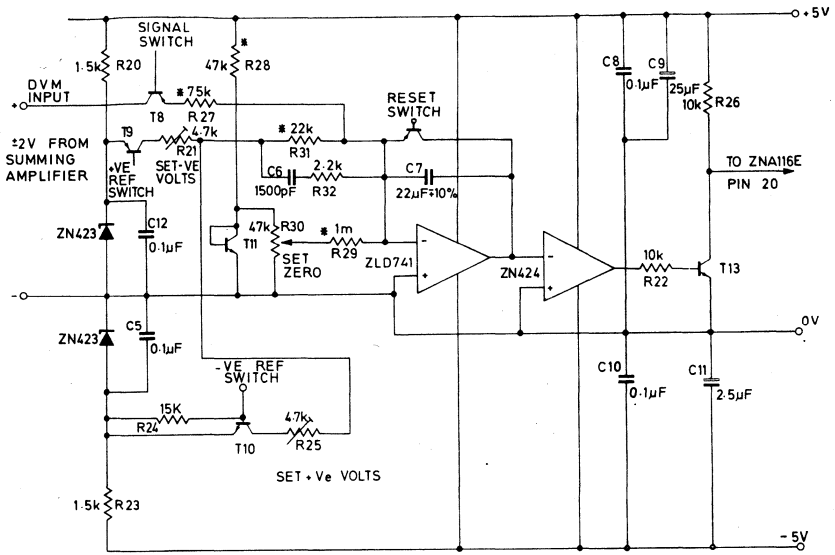

Fig. 12b Analogue switch



5076

Fig. 12c Dual slope integration circuit

* ± 2% HIGH STABILITY
ALL NPN ZTX 108
ALL PNP ZTX 213

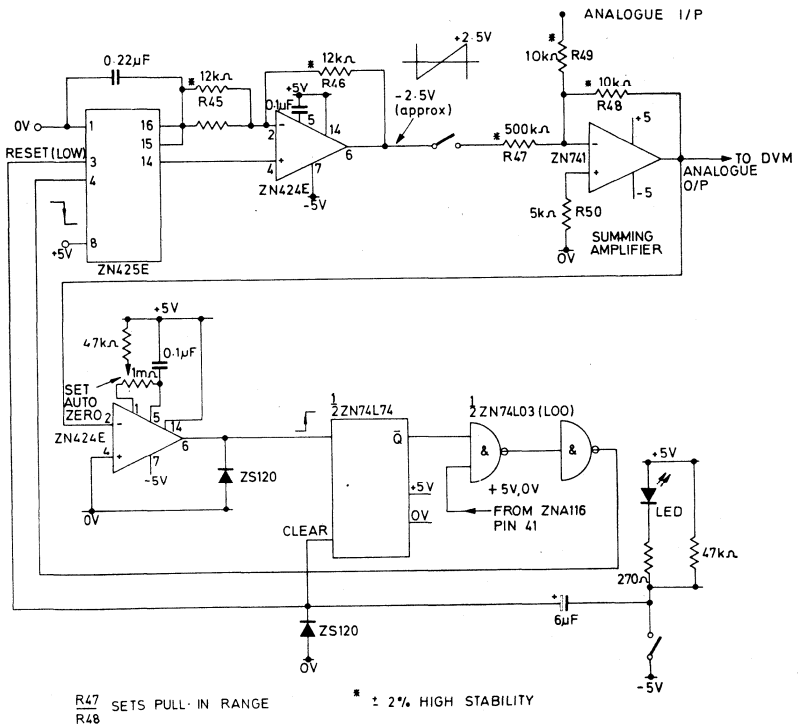

Fig. 12d Auto zero circuit

5077

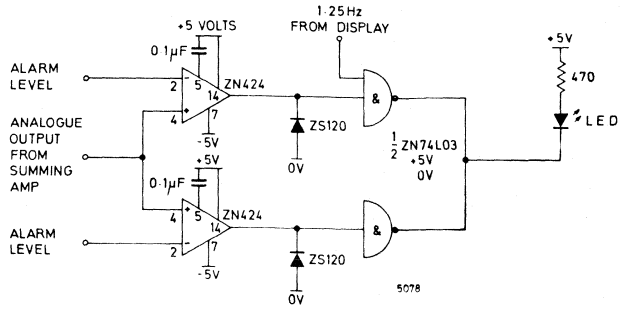

Fig. 12e Alarm circuit

3.4 Peak Detect

A peak detect circuit may be constructed simply using the form of A to D system shown in the schematic of Fig. 13. When left running continuously it will hold the maximum input signal level it is able to track, i.e. peak detect.

After application of a reset pulse, the state of the comparator enables clock pulses from the Schmitt trigger circuit to be fed to the counter of the ZN425E. The analogue output begins to ramp up until it attains the level of the analogue input voltage at which point the comparator changes state and inhibits further clock pulses. Therefore, the analogue output is held and stored digitally in the bits of the converter. It will continue to hold this level until a further increase in analogue input voltage changes the comparator state, enabling the clock, and the sequence is repeated.

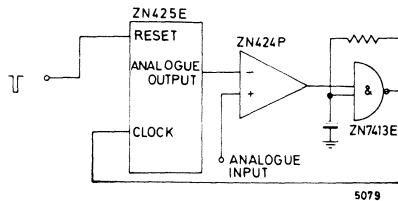

Fig. 13 Peak detect schematic

3.5 Channel Selector

Another interesting application of the A-D principle is for a channel selector in communications, e.g. citizens or amateur band. In effect it replaces a multiway switch, mechanically limited to 24 or 30 channels, by a 10 turn potentiometer which can be used with the system of Fig. 14 to generate many more discrete steps, typically 64 but up to 256.

The ZN425E, with internal counter, provides the A-D conversion function, using a single ZN7400E package for external logic, and a high performance ZN424P op-amp as comparator. A ZN7413E dual Schmitt provides the necessary clock and conversion oscillators, no sync is needed here. Channel selection is by the 10 turn potentiometer 'Main Tune' or, optionally, by preset potentiometers, to preferred channels. Resistance values for the pots are not critical.

The binary output is converted to BCD by the 74185 and latched to provide a steady output signal, i.e. when a particular channel has been selected no jumps occur during cycling. The conversion oscillator periodically checks the state of the input voltage, by a fresh conversion on the ZN425E, and updates the latches when the status command

indicates that the conversion is complete. The BCD signals drive 7-segment indication of channel number and provide the drive outputs for either a modulo-N digital synthesiser, a crystal-bank synthesiser, or a crystal selector. Features of the system are :

1. Bi-directional, quasi-continuous tuning on a single control.
2. Electronic tuning lock.
3. Simple switching between 'tune' and 'preferred channel' operation.
4. Preferred channels selected by preset potentiometers operating through to the synthesiser. Channels are user-alterable.
5. Inherent non-volatile 'memory' on potentiometers.
6. Channel number indication shows channel actually in use, particularly suitable for non-co-channel working, repeaters, etc.

In addition, a scanning facility can be easily added if the receiver used has a squelch switched output.

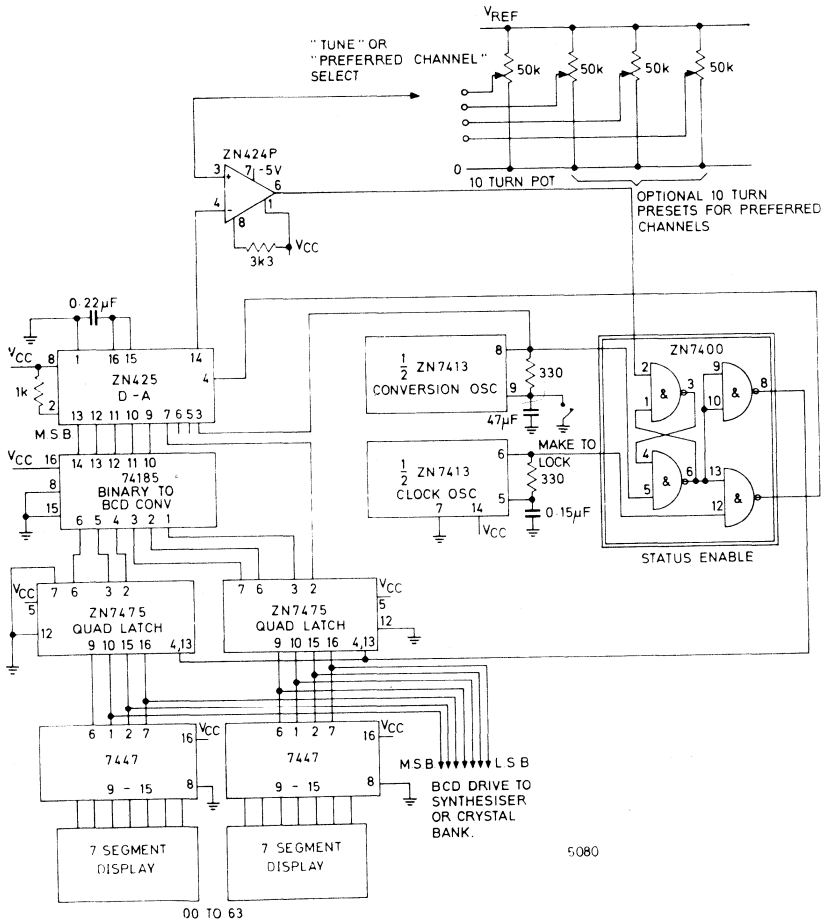

Fig. 14 Channel selector, 64 way

3.6 Bargraph Display Drive System

The ZN425E may be used in its continuous ramp mode very advantageously in conjunction with linear light emitting diode (LED) displays, e.g. Bargraphs. This is because the LED displays lend themselves to being accessed in a matrix fashion using a time sharing or multiplexing technique. This allows a reduction in the number of connections required, to $m + n$ in an array of $m \times n$ diodes (Fig. 15a) This reduction in connections also allows a simplification of the drive system, as described below.

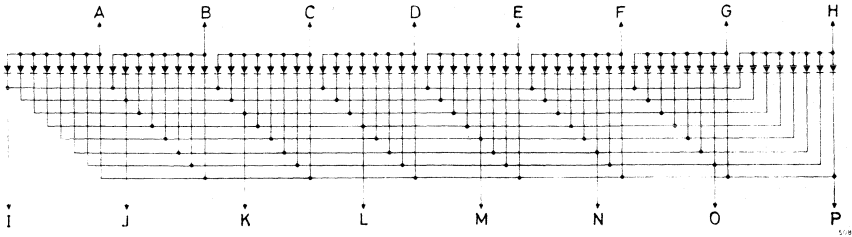

Fig. 15a Diode matrixing connections

The simplest technique for providing for a bar output whose length is proportional to an analogue input is shown in Fig. 15b. The ZN425E is driven in its continuous ramp mode. The six most significant digits from the counter are then decoded into two lots of 1 out of 8 drives. These drives then access the LEDs in a multiplexed fashion, so that the 64 LEDs are accessed once each in turn in a complete scan cycle. A high clock frequency is selected which ensures that the flicker rate is fast enough and thereby indistinguishable to the eye.

At the same time as the LED scan cycle is taking place, the ZN425E provides a staircase analogue output, as shown. This is compared with the analogue input in a comparator, whose output controls the display enable. Thus while the ramp is less than the analogue input, the LEDs being scanned are enabled (the start of the Bargraph line), while once the ramp output is larger than the analogue input, the drives to the LEDs further along the line are inhibited. This, therefore, provides an illuminated bar length proportional to the analogue input.

This system as it stands suffers from a minor disadvantage, in that the duty cycle for accessing each LED is $1/m \times n$, or $1/64$ for the case of Fig. 15b. Although the LEDs become more efficient with pulsed operation, $1/64$ duty cycle does not provide adequate brightness for some applications.

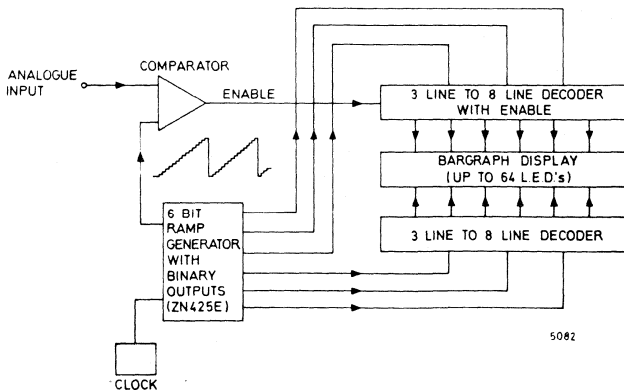

Fig. 15b Simple bar display schematic drive system

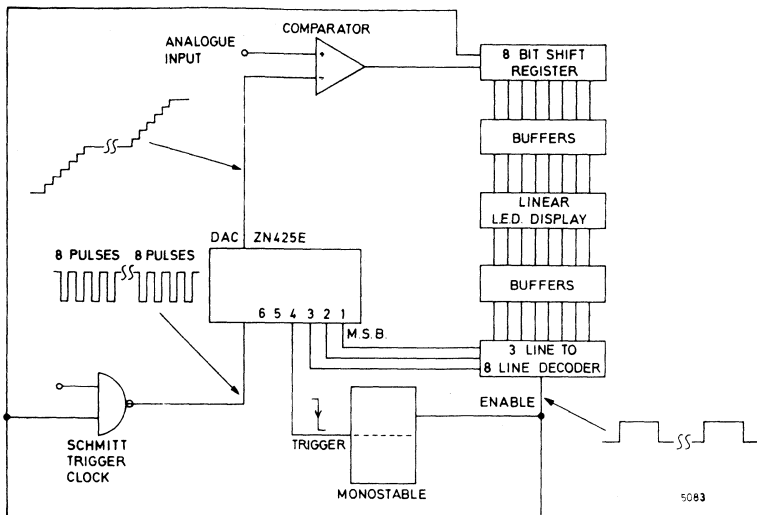

Fig. 15c Improved bar display schematic drive system

A technique to overcome this objection is shown in outline in Fig. 15c. The technique used here is to load a shift register rapidly serially, and subsequently use this register to provide LED multiplex drives in parallel. This means that the duty cycle for accessing the LEDs is improved (for a 64 LED array) from 1/64 to just less than 1/8. This is quite sufficient for acceptable brightness in virtually all applications.

This system operates as follows. While the monostable is in its mode of loading the shift register, the ZN425E staircase output increases in 8 discrete steps. Simultaneously the shift register is loaded with the comparator output to provide serial to parallel conversion. The comparator output is thus effectively changed from serial access to parallel access of the linear LED array.

When the monostable changes over to its (longer period) display mode, the LED array is accessed, and the LEDs are driven or otherwise according to the enable or disable information stored in the shift register. The display is incidentally disabled while the mono is loading the register.

To provide an example of operation, suppose the bar is to have the first 37 LEDs displayed, with the rest blanked. Starting from the ZN425E being reset and the mono in its register load state, operation is as follows.

The mono allows eight clock pulses through the gate to the ZN425E, after which the ZN425E count pulse retriggers the mono. These eight pulses generate the first eight steps from the analogue output, which produce from the comparator a continuous display enable (say logic 1). These are loaded into the shift register which thus finishes with 1111111 in parallel to the LED display.

At this point the mono is tripped into its display mode, and the counter has reached 8 (or 001 000). However the decoder must access the first eight LEDs, so that the second decoder output is connected to the first set of LEDs. These are all illuminated.

During the second register load period, the cycle is repeated, with again all ones being loaded into the register which subsequently brightens up the second eight LEDs (9–16). The same occurs during the third and fourth mono cycles, lighting up the first 32 LEDs.

During the fifth register load period, the analogue output goes up a further eight steps. However after the fifth step the comparator changes over to load zeros for the remainder of this period into the shift register. If loaded from the left the register will then finish up as 00011111. Subsequently during the mono display period LEDs 33 to 37 inclusive will be lit, but 38 to 40 will be blanked off.

The sixth to eighth mono cycles will load zeros into the shift register, blanking off LEDs 41 to 64. The full LED scan cycle is therefore completed with the desired effect.

Typical system clock rates are 400 kHz, and typical monostable periods 500 μ s for the values shown

An actual circuit to achieve this is shown in Fig. 16 and it may be seen that this is elegant and simple. The type of display which may be accessed in this way is the Bowmar Microstic R1 M-053-66A, which is connected in eights on its common anodes. This has 64 red LEDs and a further two LEDs at the ends, one to show the display is working, and the other for over-range. Similar techniques may be used with the 106 LED version.

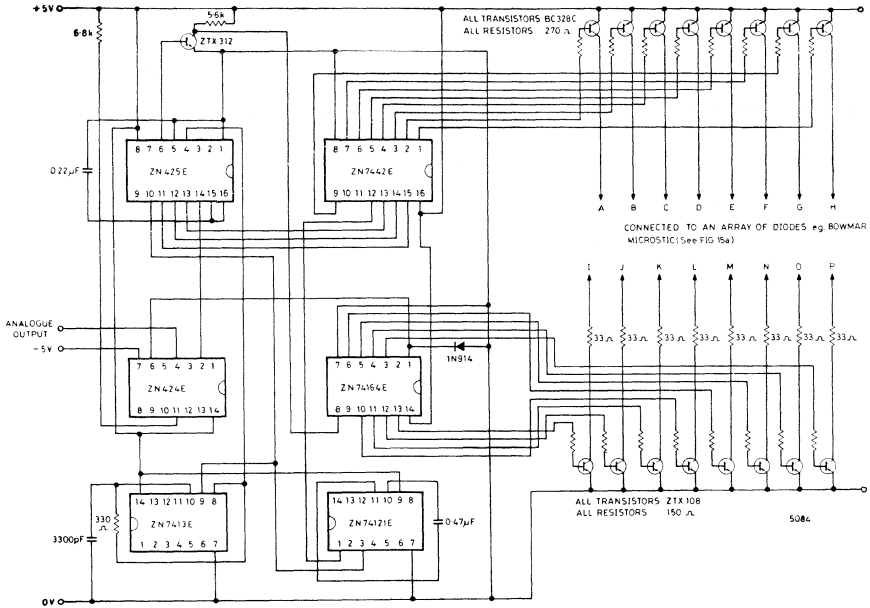

Fig. 16 Column display drive system

3.7 Up Down or Tracking

The counter on the ZN425E is only an up counter, and some systems, e.g. tracking converters or servos, may require an up/down counter. This is conveniently provided externally, e.g. the ZN74193E using the ZN425E purely in its D-A converter mode and ignoring the counter (Fig. 17). While this may appear to be inelegant it is nevertheless economically sound.

4. MULTIPLY/DIVIDE

4.1 Multiplier

The reference supply to the D-A section of the ZN425E has been purposely left on an uncommitted terminal, so as to allow connection either from its own reference or from an external reference. The point about an external reference is that it allows a multiplying effect, in that the analogue output is proportional both to the binary code and the reference voltage. For this reason this type of DAC is called a multiplying DAC.

Practical limits in multiplying voltages are 0V and 3V.

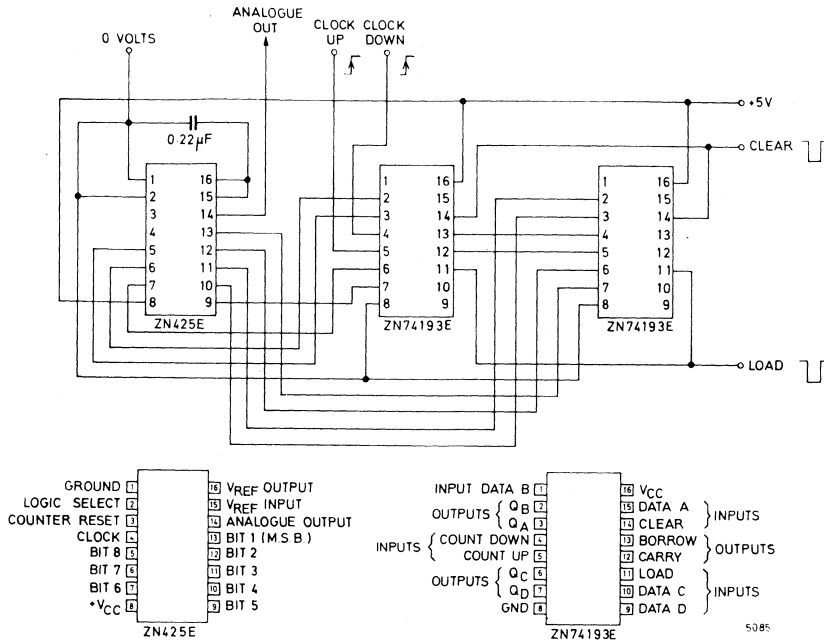

Fig. 17 Up/down counter or tracking DAC circuit

4.2 Variable Frequency Divider

If a ZN425E is operated in its continuous ramp mode in conjunction with a comparator whose output is fed back to the counter reset, a variable frequency divider can be constructed as shown in Fig. 18a. Here an analogue voltage can be used to control the number of steps before reset is applied, the overall effect being to provide variable frequency division under the control of a potentiometer.

4.3 Voltage Controlled Oscillator

The schematic of Fig. 18a may also be used as a voltage controlled oscillator. However the frequency is the inverse of the applied voltage, though the period is, of course, proportional. The corresponding circuit of Fig. 18b gives an output frequency or pulse rate which is inversely proportional to applied voltage as shown in Fig. 18c. It is, however, in some cases more desirable to produce an output frequency directly proportional to applied voltage. This is accomplished by the circuit depicted by Figs. 19a and 19b and involves the use of an inverse scaler described in the next section, for which a brief mention is necessary to understand the basic operation of the V.C.O.

By using a DAC in the feedback loop of an operational amplifier an output voltage is derived which is inversely proportional to a digital input number to the DAC. Clock pulses applied to the DAC counter will produce a repetitive output waveform which is a

hyperbolic $\frac{1}{n}$ function. This waveform is applied to the inverting input of a comparator

whilst the analogue input voltage to be frequency converted is applied to the non-inverting input. At the instant they become equal the comparator changes state and operates the Schmitt trigger which resets the DAC counter. The result is a train of negative going pulses whose frequency is directly proportional to the applied input voltage. This follows simply because if F_{Clock} = clock frequency to the DAC counter,

and F_{out} = output frequency, then $F_{\text{out}} = \frac{F_{\text{Clock}}}{n}$ where n = digital input number,

and analogue input voltage to the comparator $V_{\text{in}} \propto \frac{1}{n}$

Therefore, $F_{\text{out}} \propto V_{\text{in}}$ and the appropriate characteristic is shown in Fig. 19c.

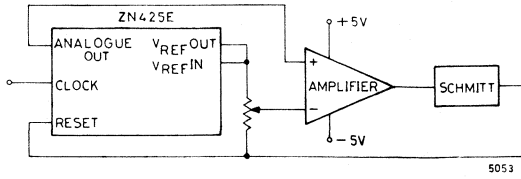

Fig. 18a Variable frequency divider or VCO schematic

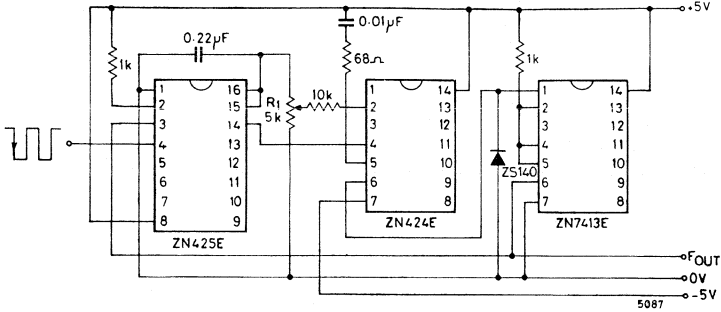

Fig. 18b Variable frequency divider or VCO circuit

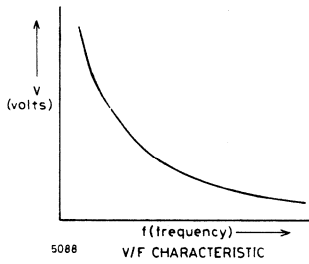

Fig. 18c VCO characteristics

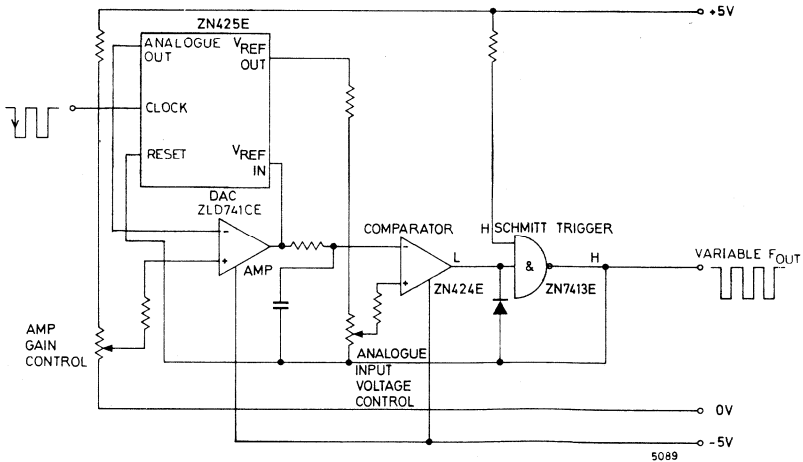

Fig. 19a Schematic of VCO giving frequency proportional to voltage

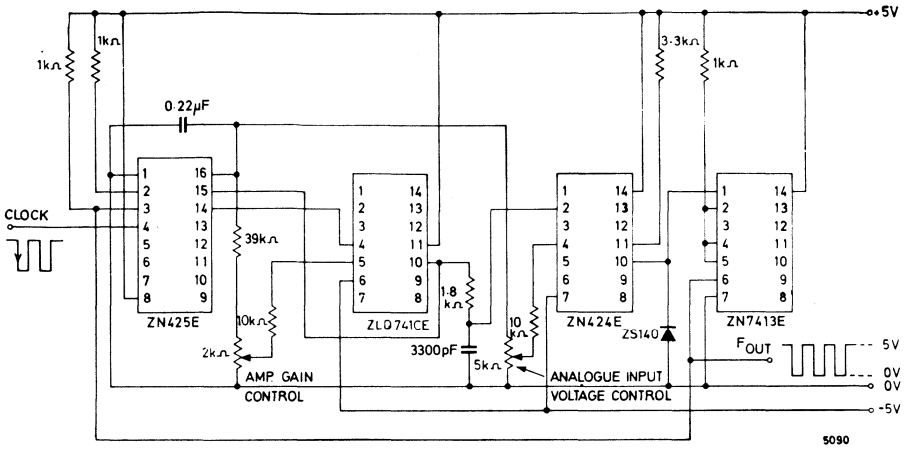

Fig. 19b Circuit of VCO giving frequency proportional to voltage

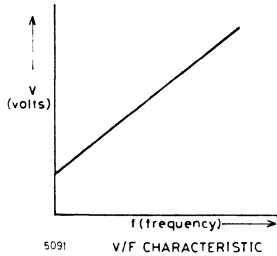

Fig. 19c VCO characteristics

5. FUNCTION GENERATION

By virtue of the multiplying function, the ZN425E may also be used for function generation as described below.

5.1 Inverse Scaler

If a DAC is operated in the feedback loop of an operational amplifier then the amplifier gain is inversely proportional to the input digital number or code to the DAC. The version giving scaling inversely proportional to positive voltage is shown in the schematic of Fig. 20a and the practical circuit of Fig. 20b.

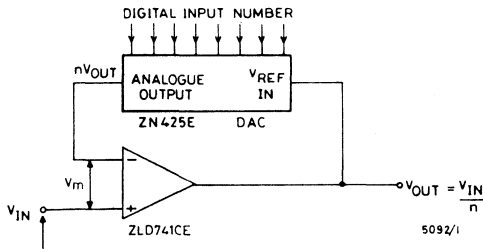

Fig. 20a Inverse scaler schematic

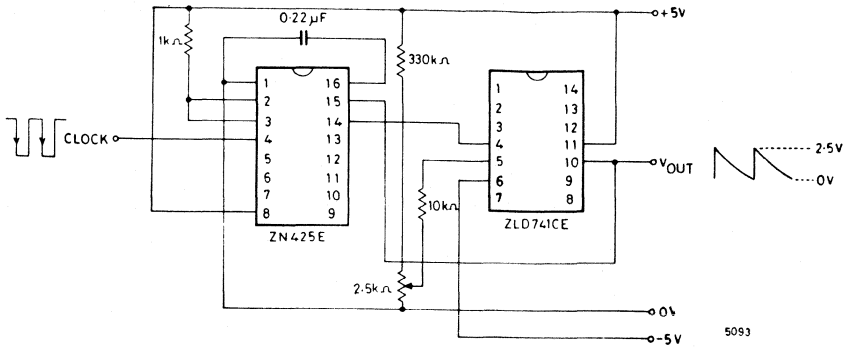

Fig. 20b Inverse scaler circuit

If A = open loop gain of the operational amplifier, and n is a fractional number representing any digital input (00000000 to 11111111 for 8 bits), that is a fractional number between 0 and $\frac{255}{256}$ then from the diagram $V_{out} = AV_m$, and $V_m = (V_{in} - n V_{out})$

$$\therefore V_{out} = A (V_{in} - n V_{out}) \text{ from which } V_{out} (1 + An) = AV_{in} \frac{V_{out}}{V_{in}} = \frac{A}{1 + An}$$

$$\text{Since } An \gg 1, (A \approx 100,000) \text{ then } \frac{V_{out}}{V_{in}} = \text{Gain } (G) \approx \frac{A}{An} = \frac{1}{n}$$

For $n = 1 \text{ LSB} = \frac{1}{256}$ then the maximum allowable input voltage V_{in} to prevent saturation ($V_{sat} \approx 4V$) = $\frac{4}{256} \approx 15 \text{ mV}$.

If $n = 0$ then $G = A$ and for a fixed input level the amplifier output will normally be equal to the saturation voltage since $A \approx 100,000$.

The complementary mode (scaling inversely proportional to negative voltage) is shown in Fig. 20c (schematic) and Fig. 20d (practical circuit).

$$V_m = \left[V_{in} - \left(\frac{V_{in} - n V_{out}}{R_I + R_F} \right) \right], \text{ and } V_{out} = -AV_m$$

If $\frac{R_I}{R_F} = F_I =$ inverting feedback return then

$$V_{out} = -A \left[V_{in} - \left(\frac{V_{in} - n V_{out}}{1 + F_I} \right) F_I \right]$$

$$\text{From which } V_{out} = - \left[\frac{A V_{in}}{1 + F_I + nAF_I} \right]$$

If the input voltage V_{in} is negative with respect to ground, then

$$\text{Gain } (G) = \left[\frac{A}{1 + F_I + nAF_I} \right]$$

$$\text{If we make } F_I = 1, \text{ i.e. } R_I = R_F \text{ then } G = \left[\frac{A}{2 + nA} \right]$$

But $nA \gg 2$ (since $A \approx 100,000$)

and $G = \frac{A}{nA} = \frac{1}{n}$ as with the non-inverting circuit.

Figs. 20a and 20c illustrate both types of inverse scalars, where a repetitive waveform of a $\frac{1}{n}$ function is generated by feeding clock pulses to the counter of the DAC.

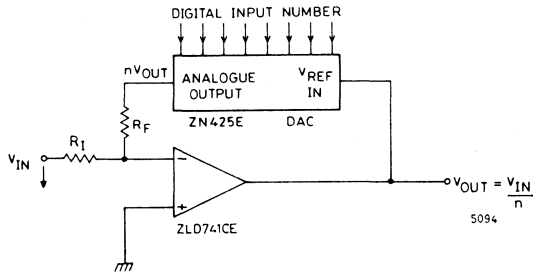

Fig. 20c Complementary inverse scaler schematic

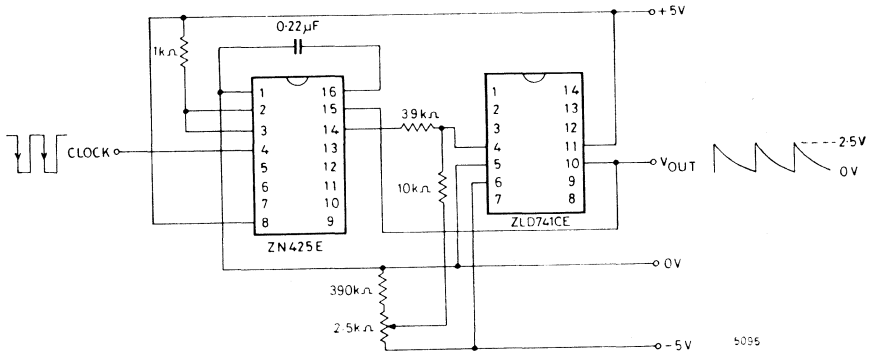

Fig. 20d Complementary inverse scaler circuit

5.2 Parabola

The multiplying action of the ZN425E may be used to generate a parabolic waveform shown schematically in Fig. 21a and a practical circuit Fig. 21b.

Basically the circuit operates as follows :

A continuous ramp output is generated by feeding clock pulses to the counter of a ZN425E DAC using its internal reference which is buffered, level shifted, and finally inverted using two operational amplifiers, so that the inverted ramp starts at a peak amplitude ($V_{1\text{ REF}} = 2.5\text{V}$) and decreases linearly to zero. This is then used as an external reference supply for a second ZN425E DAC whose bits are connected to the first DAC for synchronous clocked operation. The resulting analogue output from the second DAC is a repetitive parabolic waveform whose peak amplitude is equal to $\frac{V_{1\text{ REF}}}{4} = \frac{2.5}{4} = 0.625\text{V}$.

This follows because,

If $N = a$ a fractional number representing the digital input to both DACs then the analogue output voltage from the first DAC = An (where $A = V_{1\text{ REF}} = 2.5\text{V}$).

This is then inverted and level shifted to provide the reference voltage to the second DAC = $(A - An) = V_{2\text{ REF}}$.

Therefore the analogue output from the second DAC = $n(A - An) = An - An^2$ which is the equation of a parabola about the x axis of the form $y = ax^2 + bx + c$.

Peak amplitude of the parabola occurs when $n = \frac{1}{2}$

for which $V_{\text{out}} = \frac{1}{2} \left(A - \frac{A}{2} \right) = \frac{A}{4} = \frac{V_{1\text{ REF}}}{4}$ as stated.

It should be noted that the ramp output from the non-inverting buffer amplifier will inherently have a gain greater than unity, and therefore its peak amplitude will be some factor in excess of $V_{1\text{ REF}}$. However the ramp inverter and level shifter introduces corresponding attenuation to compensate this so that gain and level shift controls provide adequate adjustment in obtaining the desired inverted ramp output of peak amplitude.

$$A = V_{1\text{ REF}} = 2.5\text{V.}$$

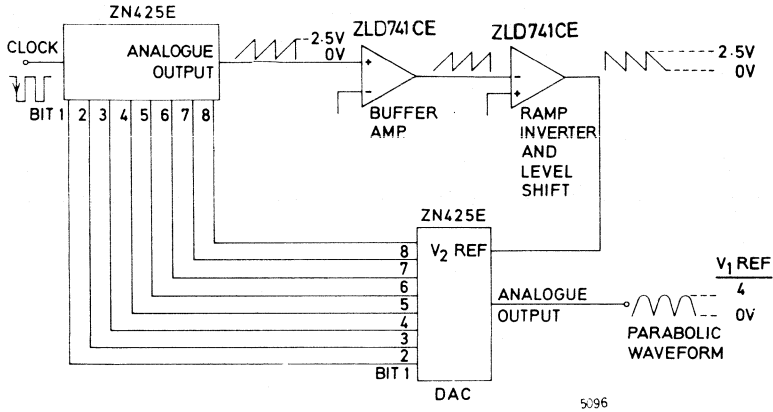

Fig. 21a Parabolic waveform generator schematic

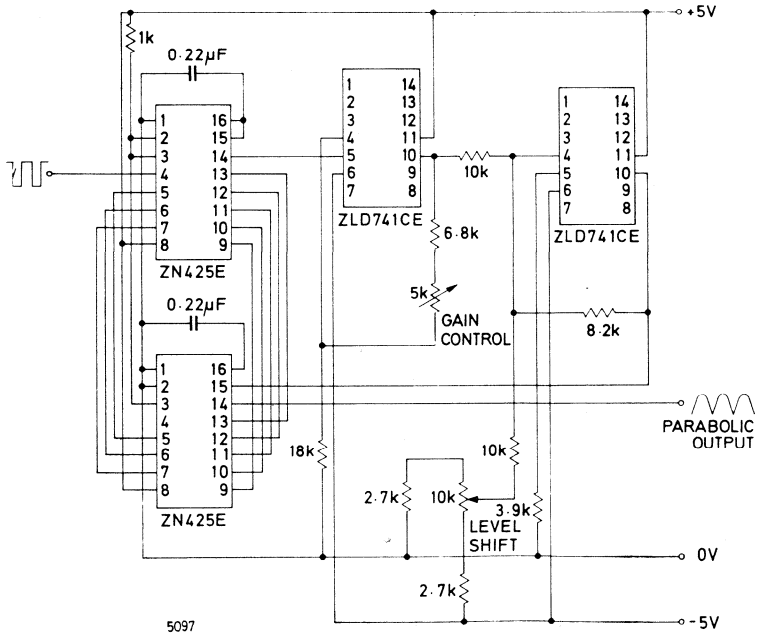

Fig. 21b Parabolic generator circuit

5.3 Log Approximation

A more complex function $y = \log n$ can be performed with the aid of previously described building blocks. A schematic arrangement as shown in Fig. 22a and the corresponding practical circuit of Fig. 22b provides a repetitive logarithmic relationship. The basic method is as follows.

An inverse scaler is used to generate an output voltage which is inversely proportional to a digital input number n to a ZN425E DAC. This voltage is then converted to a frequency or pulse rate using a VCO whose output frequency is proportional to an applied voltage. The derived train of pulses of varying mark to space ratio are then fed into the counter of a final ZN425E DAC, these are integrated and a logarithmic output $\int \left(\frac{1}{n} dn = \log n\right)$ is obtained.

The period of the analogue $\frac{1}{n}$ function is dependent upon the input frequency to the inverse scaler. To rapidly convert this function to a pulse train and to generate a sufficient number of pulses for integration during this period, the clock frequency to the VCO derived from the Schmitt trigger must be high. The lower input frequency to the inverse scaler in synchronism with this clock frequency is obtained by using two ZN7493A dividers and equals the clock frequency divided by 256. For the CR values indicated in the Schmitt trigger $F_{\text{Clock}} \approx 512 \text{ kHz}$ therefore the input frequency to the inverse scaler $= \frac{512 \times 10^3}{256} \text{ Hz} = 2000 \text{ Hz}$. And the output repetition frequency of the $\frac{1}{n}$ function $= \frac{2000}{256} \text{ Hz}$, for which the period $= \frac{256\text{s}}{2000} = 128 \text{ ms}$.

Some means must be incorporated of resetting the counter on the final ZN425E DAC and thereby the logarithmic analogue output to zero at the completion of a full cycle of input pulses. Otherwise the analogue output would continue to increase with each cycle of pulses until it equalled the internal reference voltage, resulting in a 3 cycle logarithmic waveform. This is accomplished by using the negative going edge from the 4th significant bit which in fact resets the counter on the final DAC before the completion of a full cycle of input pulses. Whereas to be strictly correct resetting should be effected from the MSB ; bit 4 having been selected purely for convenience as it allows the logarithmic characteristic to be more easily displayed on the oscilloscope, since it accounts for a greater proportion of the output waveform, with negligible loss in amplitude.

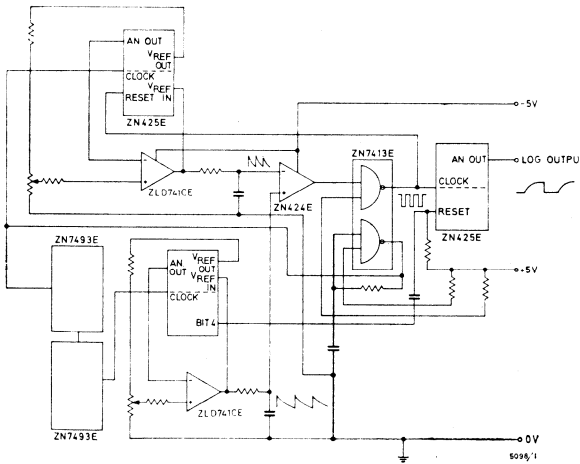

Fig. 22a Logarithmic waveform generator schematic

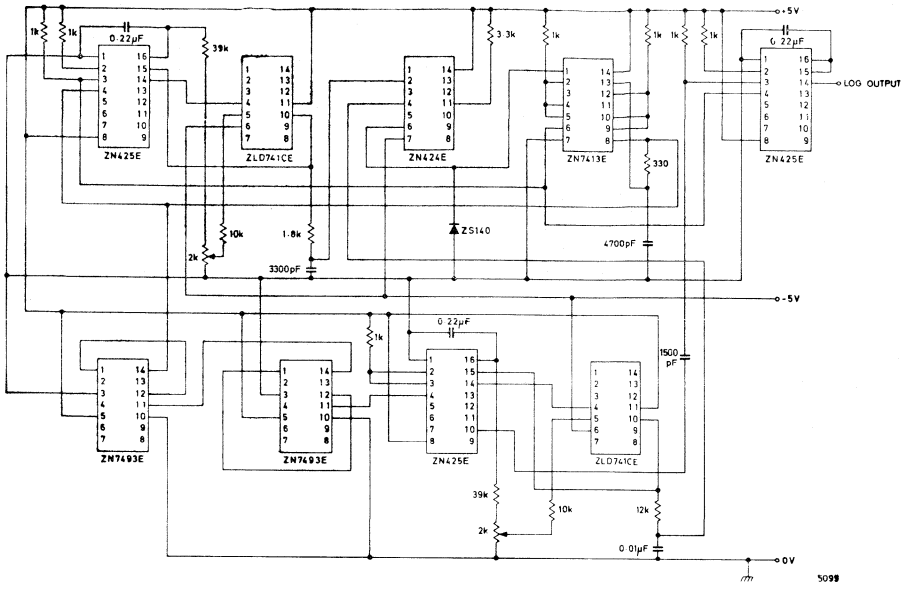

Fig. 22b Logarithmic waveform generator circuit

Microprocessor Interfacing Using The ZN427/ZN428 Data Converters

Analogue I/O Interface System for the 6800 Microprocessor

Interfacing the ZN427 A to D Converter with the Microprocessor System

Interfacing the ZN428 D to A Converter with the 8085A Microprocessor System

Analogue I/O Interface System for the 6800 Microprocessor

By SCOTT BIRD, Feranti Electronics Ltd.

Conventional Analogue I/O systems for Microprocessors are generally high accuracy, high cost, hybrid module/P.C. board assemblies, available only in one fixed configuration of I/O channels, (i.e. 16 Input and 2 Output channels). This Application Note describes how a low cost Analogue I/O system may be produced for the 6800 microprocessor using FERRANTI ZN427 A/D and ZN428 D/A converters with the 6820/6821 Peripheral Interface Adapter (PIA) I.C. This combination produces a versatile system which can be configured to the designer's particular I/O requirements, and which can also be expanded without major modifications to the hardware. The advantages of interfacing to the microprocessor via the PIA are that it provides a simple, easily expandable system, without additional address decoding and line buffering hardware, and it also simplifies timing problems associated with a direct bus interface.

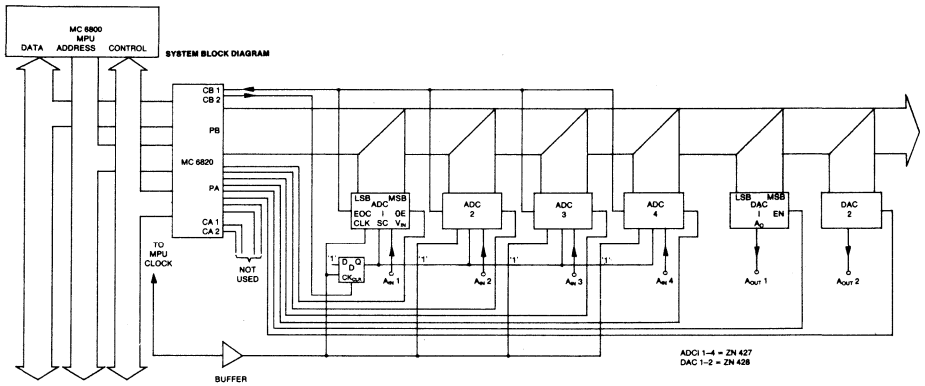

Fig. 1 System Block Diagram

The ZN427 A/D Converter

The ZN427 is an 8-bit, successive approximation A/D Converter. It features fast 15 μ s conversion time, three-state outputs to permit bussing on common data lines and no missing codes over the full operating temperature range. The ZN427 contains a voltage switching D/A converter, a 2.5 V precision band gap reference, a fast comparator, successive approximation logic, and three-state output buffers.

Operation of the ZN427 is best described with reference to the timing diagram—Fig. 3. Conversion is initiated by a START CONVERT (SC) pulse which can be applied asynchronously with respect to the ZN427 clock providing the following criteria are met.

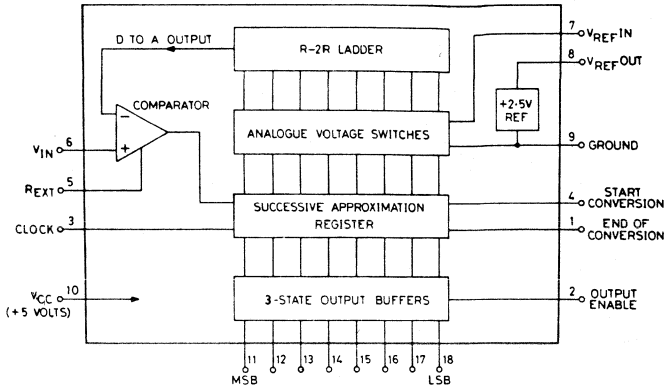

Fig. 2 ZN427 Logic Diagram

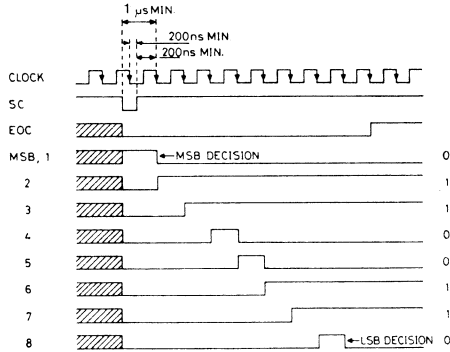

Fig. 3 Timing Diagram

1. The leading edge of the SC-pulse should precede the first active (negative going) edge of the clock (after the trailing edge of the SC pulse) by at least $1.5 \mu\text{s}$ to allow for MSB setting.
 2. The trailing edge of the SC pulse must not occur within $\pm 200 \text{ ns}$ of a negative going edge of the clock.
 3. As a special case of conditions (1) and (2) the SC pulse may be coincident with, and of the same duration as, a negative going clock pulse.
- Application of the SC pulse sets MSB to a '1' level and all other bits to a '0', which produces a voltage output from the D to A converter of $V_{\text{REF IN}}/2$. This value is compared with the input voltage V_{IN} , and a decision is made on the first negative clock edge to set the MSB to '0' if $V_{\text{REF IN}}/2 > V_{\text{IN}}$, or else to keep it at '1'. Bit 2 is switched to '1' on the same clock edge, and on the next edge a decision is made about Bit 2, again by comparing the D/A output with V_{IN} . This process is repeated for all eight bits so that when the END OF CONVERSION (EOC) output goes high the digital output from the converter is a valid representation of V_{IN} . The binary output is latched until the next START pulse. The three-state data outputs are OFF (high impedance) when OUTPUT ENABLE (OE) is an '0' and are enabled when the OE input is taken to '1'.

The ZN428 D/A Converter

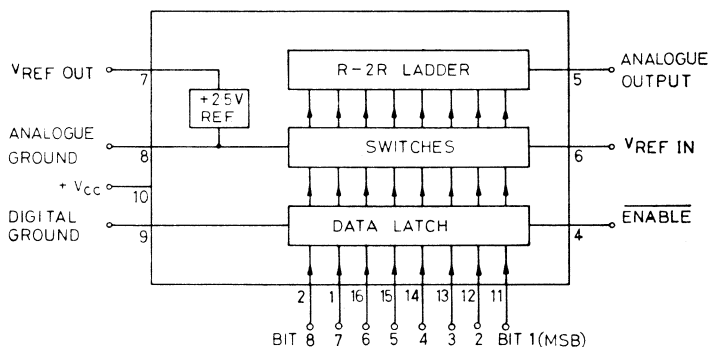

Fig. 4 Logic Diagram

The ZN428 is a monolithic 8-bit D/A converter with input latches to facilitate updating from a data bus. The latch is transparent when ENABLE is at logic '0' and the data is held when ENABLE is taken to logic '1'. The ZN428 features single +5 volt supply requirements, fast 800 ns settling time and is guaranteed monotonic over the full operating range. It also contains a 2.5 volt reference the use of which is pin optional to retain flexibility. An external fixed or varying reference may therefore be substituted. The converter is of the voltage switching type and uses an R-2R ladder network. Each 2R element is connected to 0 volt or $V_{\text{REF IN}}$ by transistor voltage switches specially designed for low offset voltage (1 millivolt). A binary weighted voltage is produced at the output of the R-2R ladder network the nominal output range of the ZN428 being 0 V to $V_{\text{REF IN}}$ through a 4 k Ω resistance. Other output ranges can readily be obtained by using an external amplifier.

The 6800 Microprocessor System

It is assumed that the reader is fully conversant with the 6800 microprocessor family, information on which can be found in the Motorola M6800 Microprocessor Applications Manual, so only a brief description is given here.

The 6800 is an 8-bit monolithic microprocessor which forms the central control function for the 6800 microprocessor family. Fully compatible with TTL the 6800 requires only a single + 5 volt power supply, it features an instruction set of 72 instructions with 7 addressing modes and full 65 k byte memory addressing capability. The microprocessor communicates with its external memory and all I/O devices via an 8-bit bi-directional data bus and a 16-bit address bus.

The 6820/21 Peripheral Interface Adaptor (PIA) provides a flexible means of interfacing byte-orientated peripherals to the microprocessor, through two 8-bit bi-directional peripheral data lines and four control lines. The functional configuration of the PIA is under the full control of the microprocessor. Each of the peripheral data lines can be programmed to act either as an input or output, and each of the four control/interrupt lines may be programmed for one of several control modes. This allows a high degree of flexibility in the overall operation of the interface.

The Analogue I/O Interface

The system described in this application note provides 4 Analogue Input and 2 Analogue Output channels—see the System Block Diagram Fig. 1 and the detailed Circuit Diagram Fig. 5. Other configurations can easily be produced—these are discussed later in this note.

The peripheral data lines PB0–PB7 of the PIA are connected to the binary data outputs of the ZN427s and the data inputs of the ZN428s to produce a common 8-bit data bus for the converters. Peripheral lines PA0–PA5 are programmed as OUTPUTS and provide individual OUTPUT ENABLE and ENABLE signals for the ZN427 and ZN428 respectively. A common, simultaneous START CONVERT signal for the ZN427s is produced from the CB2 control line programmed in the SET/RESET output mode and used in conjunction with a 'D' type flip-flop. The END OF CONVERT outputs from the ZN427s are commoned together and drive the CB1 input of the PIA which can be programmed to generate a microprocessor interrupt signal. In this system configuration, the peripheral lines PA6, PA7 and the control lines CA1, CA2 are not used.

The ZN427 clock signal can be generated either asynchronously from an external source or from the microprocessor clock. If using the MC6871B microprocessor clock device (as supplied with the Motorola MEK6800D2 Evaluation Kit), which produces a 614.4 kHz clock signal, then the ϕ 2 TTL output of this can be used directly. Note that the maximum clock frequency of the ZN427 is specified as 600 kHz, although the device will function up to greater than 1 MHz, but at reduced accuracy due mainly to the response time of the comparator. Therefore, if using a microprocessor with a clock frequency greater than 600 kHz, then this can either be divided down to less than 600 kHz, or it may be used directly up to approximately 1 MHz if some loss of accuracy can be tolerated. The advantage of using the microprocessor clock over an external clock is that it allows an accurate calculation of the conversion time to be made in terms of the microprocessor machine cycles eliminating the need to use microprocessor interrupts.

The START CONVERT pulse is generated using a 'D' type flip flop ($1/2$ ZN74L74) in order to meet the timing requirements discussed earlier. A conversion cycle is initiated by outputting a logic '0' followed by a logic '1' from the CB2 line of the PIA. This drives the CLEAR input of the 'D' type and sets the START CONVERT (SC) input of each 427 to a logic '0' via the Q output. The first positive going clock edge after the CLEAR input is returned to a logic '1' will clock the 'D' type and set the SC input of each ZN427 to a '1' allowing the conversion cycle to proceed. Note that while the SC input of the ZN427 is at a logic '0' level the MSB output will be driven to a logic '1' and all other data outputs to a logic '0' and the conversion cycle will be held. On the 9th negative clock edge after the START pulse the END OF CONVERSION outputs will go to a logic '1' signifying the end of the conversion cycle. This can be detected by programming the

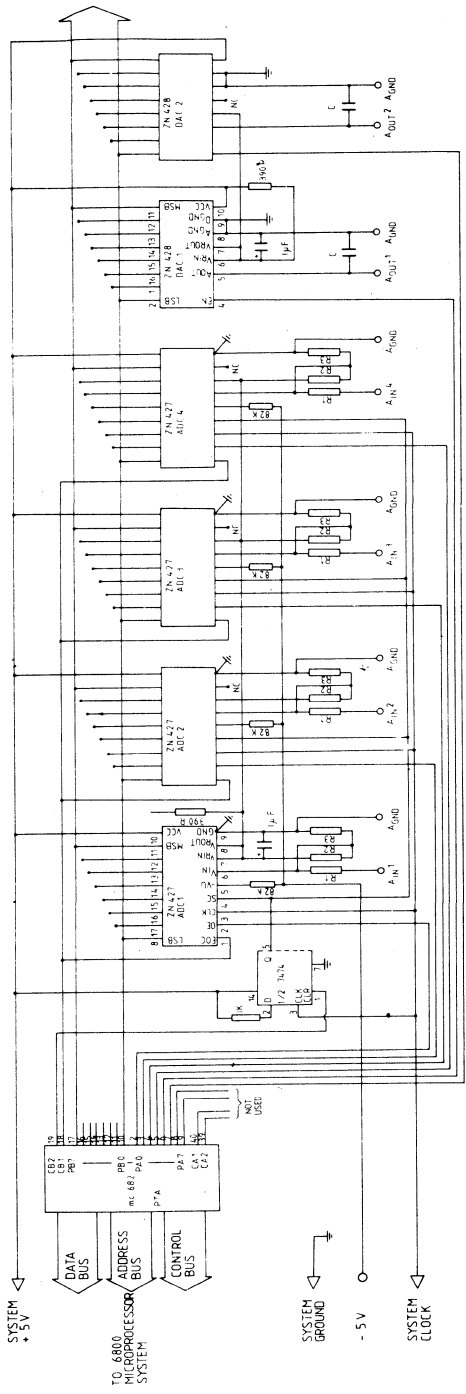

NOTE FOR 10 V UNIPOLAR OPERATION -
 R1 = 10 K POT + 11 K IN SERIES
 R2 = 5 K Ω
 R3 = 1A.POT + 680 K IN SERIES

FIG 5 - SYSTEM CIRCUIT DIAGRAM

PIA to set the microprocessor interrupt input on the positive going edge of the CB1 control line. The EOC outputs of up to four ZN427s can be "wire or'd" together to produce a common interrupt line as shown in Fig. 5. Alternatively, if using the microprocessor clock (at up to 1 MHz), then the EOC output will always occur within 10 microprocessor machine cycles after the instruction setting the CB2 control line back to a logic '1'. A suitable fixed delay can therefore be built into the program to allow for the conversion time.

The binary output data of each ADC can be read by programming the peripheral lines PB0–PB7 as INPUTS and loading the data onto the converter bus by outputting a logic '1' on the appropriate PA peripheral line in order to enable the 3-state output buffers of the ADC. A microprocessor read instruction of the PIA peripheral register 'B' will then transfer the data to the microprocessor. Obviously the program should be so arranged that, in order to avoid bus contention problems, only one ADC is enabled at any one time.

The circuit diagram, Fig. 5 shows the ZN427s connected for a unipolar input range of 0 to + 10 volts. Other ranges, eg + 5 V, ± 10 V and ± 5 V, can readily be obtained by using a simple resistor network as shown in the ZN427 data sheet.

The negative supply shown for the ZN427 is from – 5 volts through an 82 k Ω resistor. By suitable choice of resistor value any negative supply between – 3 and –30 volts may be used. For applications where only a single + 5 volt supply is available, a simple diode pump circuit can be used to generate the negative supply. Further information on the negative supply and a diode pump circuit suitable for up to 5 ZN427s is shown in the data sheet.

Data is outputted from the system by programming the peripheral data lines PB0–PB7 as OUTPUTS and writing the binary data from the microprocessor into the PIA peripheral register 'B'. The $\overline{\text{ENABLE}}$ input of the relevant ZN428 is driven to a logic '0' and back to logic '1' via the appropriate PA peripheral line, which will transfer the data from the converter bus to the input data latches of the ZN428. Again the programmer must ensure during an output data transfer that all the ZN427s and the other ZN428 are disabled.

The Analogue Outputs of the ZN428 are shown, taken directly from pins 5 and 8 which will provide an output range from 0 volts to $V_{\text{REF IN}}$ through a 4 k Ω output resistance. A small capacitor can be connected across the output pins as shown in order to remove any "glitches" which may be present. The value of this capacitor depends on the system noise and the response time required, however for the minimum specified settling time it should not be greater than 100 pF. An output buffer amplifier was omitted from the ZN428 design in order to allow optimum settling time, flexibility and lowest cost. Both Unipolar and Bipolar output ranges can readily be obtained by using an external amplifier, details of which are given in the ZN428 data sheet.

The ZN428 is provided with separate Analogue and Digital ground pins. These can normally be connected together close to the device and taken to signal ground. However for noisy systems or environments it may be advisable to keep the Analogue ground pins for each individual ZN428 separate from the Digital ground pin, and to connect each Analogue ground to a single common earth point in the system away from sources of digital noise such as clock oscillators, digital buses, etc. The Analogue output ground line or terminal should also be taken direct to this common earth point. (Note: The maximum voltage between Analogue and Digital grounds is limited to 200 mV.)

A common reference voltage can be provided by connecting the $V_{\text{REF OUT}}$ pin of one converter to the $V_{\text{REF IN}}$ pins of up to five converters (i.e. either ZN427s or ZN428s). This useful feature saves power and gives excellent gain tracking between converters. Fig. 5 shows the four ZN427s driven from one internal reference and the two ZN428s from another.

Note that in this application the dynamic characteristic of the ZN427/428 (i.e. Enable/Disable delay times, etc.) should not present any problems since they are much less than the microprocessor instruction execution times and need not be considered in the programming.

Program Example

A simple program which illustrates the ease of controlling the ZN427/428 with the PIA is shown on page together with the Flow Diagram, Fig. 6. The object of the program is to read the analogue voltage inputs to ADCs 1 and 2, calculate the mean value and output this on DAC1. A similar operation is performed on the inputs of ADCs 3 and 4 and outputted on DAC2.

It is assumed that the PIA has been reset which has the effect of zeroing all the PIA registers. This sets all the peripheral and control lines as INPUTS and disables the interrupts. Initially the Index Register is loaded with the PIA base address in order that the Indexed Addressing Mode can be used throughout the program to address the PIA. The peripheral lines PA0–PA7 are programmed as OUTPUTS and the Control Registers set so that control line CB2 operates in the SET/RESET output mode and the interrupt Flag bit CRB-7 is set with a positive going edge on control line CB1. All the converters are disabled by outputting 30H on the PA lines which sets the OUTPUT ENABLE inputs of the ZN427s to a logic '0' and the ENABLE inputs of the ZN428s to a logic '1'. A dummy read is made of the B Data Register to clear the Interrupt Flag bit CRB-7.

A START signal is then generated via control line CB2 by toggling bit CRB-3 in Control Register B. The end of the conversion cycle is detected by testing the Interrupt Flag bit CRB-7 and looping at this point in the program until it goes to a '1'. (Note: The microprocessor interrupt request lines TRQA, TRQB are disabled.) The output of ADC1 is now read by driving peripheral line PA0 to a logic '1', and the data is stored in the microprocessor Accumulator B, ADC2 is read in a similar way by setting PA1 line to a logic '1' and storing the data in Accumulator A. The mean value of the readings is found by adding the Accumulators and rotating the result right, one bit through carry, this is equivalent to dividing by 2. The result is saved in the memory location labelled 'TEMP 1'. The process is repeated on ADC3 and ADC4, enabling the ADC outputs by setting lines PA2 and PA3 in turn to a logic '1', and storing the computed result in location 'TEMP 2'.

The Data Direction Register B is now accessed and the peripheral lines PB0–PB7 changed to OUTPUTS. The data stored in 'TEMP 1' is outputted onto the converter bus and DAC 1 enabled by toggling line PA4 in a logic 1-0-1 sequence, which will transfer the binary data from the bus to the DAC input latches and hence to the Analogue Output. A similar sequence is performed on DAC2 with the data from 'TEMP 2', using PA5 line to drive the ENABLE input. The program is terminated with a Software Interrupt, SW1, returning control to the Monitor Program.

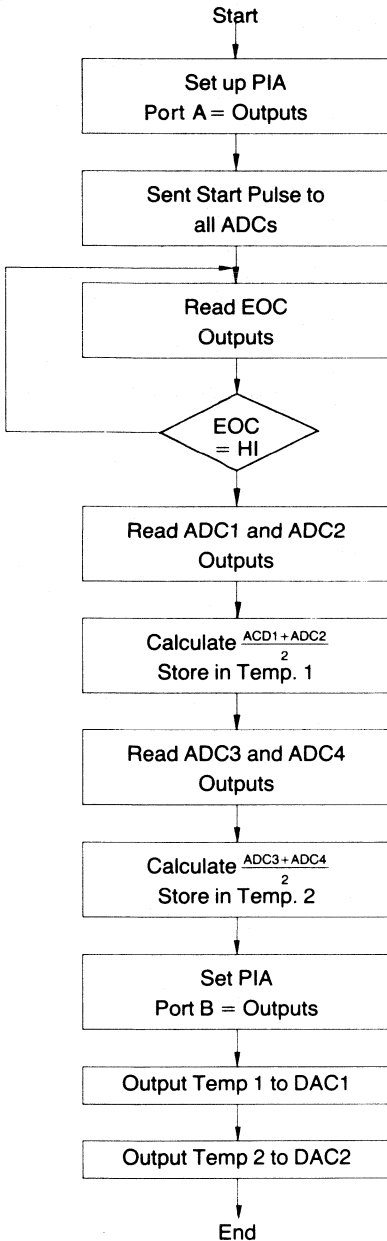

PIA PORT ALLOCATIONS

PORT A

PA0	ADC1 OE	Input
PA1	ADC2	" "
PA2	ADC3	" "
PA3	ADC4	" "
PA4	DAC1 \overline{EN}	Input
PA5	DAC2	" "
PA6	NOT USED	
PA7	NOT USED	

PORT B

PB0	BINARY DATA LSB		
PB1	"	"	LSB + 1
PB2	"	"	LSB + 2
PB3	"	"	LSB + 3
PB4	"	"	LSB + 4
PB5	"	"	LSB + 5
PB6	"	"	LSB + 6
PB7	"	"	MSB

CONTROL

CA1	NOT USED
CA2	NOT USED
CB1	COMMON EOC OUTPUT
CB2	COMMON START LINE

PIA ADDRESSES

8004	PERIPHERAL/DATA DIRECTION REG. A
8005	CONTROL REG. A
8006	PERIPHERAL/DATA DIRECTION REG. B
8007	CONTROL REG. B

FIG. 6 PROGRAMME FLOW DIAGRAM

6800/6820 I/O INTERFACE – PROGRAM EXAMPLE

LOC	OBJ	COMMENT	SOURCE STATEMENT
0000	CE8004	LDX #8004	Load PIA address to IX
3	86FF	LDA A #FF	
5	A700	STA A 0, X	Set Port A as outputs.
7	863E	LDA A #3E	
9	A701	STA A 1, X	Set Control Reg. A
B	A703	STA A 3, X	Set Control Reg. B
D	8630	LDA A #30	
F	A700	STA A 0, X	Disable Converters
11	A602	LDA A 2, X	Dummy read to Clear Flag
13	8636	LDA A #36	
15	A703	STA A 3, X	Set CB2 Low to
17	863E	LDA A #3E	Generate Start Pulse
19	A703	STA A 3, X	Set CB2 High
1B	A603	LDA A 3, X	Read Control Reg. B
1D	8580	BIT A #80	Test for CRB-7 High
1F	27FA	BEQ TEST	ie End of Conversion
21	8631	LDA A #31	
23	A700	STA A 0, X	Enable ADC1 O/Ps
25	E602	LDA B 2, X	Read ADC1 O/P
27	8632	LDA A #32	
29	A700	STA A 0, X	Enable ADC2 O/Ps
2B	A602	LDA A 2, X	Read ADC2 O/P
2D	1B	ABA	Add ADC1 + ADC2 Readings
2E	46	RORA	Divide by 2
2F	976E	STA A Temp.1	Save x in Temp. 1
31	8634	LDA A #34	
33	A700	STA A 0, X	Enable ADC3 O/Ps
35	E602	LDA B 2, X	Read ADC3 O/P
37	8638	LDA A #38	
39	A700	STA A 0, X	Enable ADC4 O/Ps
3B	A602	LDA A 2, X	Read ADC4 O/P
3D	1B	ABA	Add ADC1 + ADC2 Readings
3E	46	RORA	Divide by 2
3F	976F	STA A Temp.2	Save y in Temp. 2
41	8630	LDA A #30	
43	A700	STA A 0, X	Disable ADC O/Ps
45	863A	LDA A #3A	
47	A703	STA A 3, X	
49	86FF	LDA A #FF	
4B	A702	STA A 2, X	Set Port B as outputs
4D	863E	LDA A #3E	
4F	A703	STA A 3, X	
51	966E	LDA A Temp. 1	
53	A702	STA A 2, X	Put x Data on bus
55	8620	LDA A #20	
57	A700	STA A 0, X	Enable DAC1 L/Ps
59	C630	LDA B #30	
5B	E700	STA B 0, X	Disable DAC1 L/Ps
5D	966F	LDA A Temp. 2	
5F	A702	STA A 2, X	Put y data on bus
61	8610	LDA A #10	
63	A700	STA A 0, X	Enable DAC2 L/Ps
65	E700	STA B 0, X	Disable DAC2 L/Ps
67	3F	SWI	End
006E	00	Temp. 1	x data
006F	00	Temp. 2	y data

Summary

The system described in this report is by no means restricted to the configuration shown. Provided that the drive capability of the system components is not exceeded, the number and configuration of ZN427s and ZN428s which can be employed is limited only by the I/O lines available from the PIA, hence providing the Design Engineer with a wide degree of freedom in producing the system that best fulfils his requirements.

The major loading and drive characteristics of the various system components are shown in Table 1. Buffer gates can be employed where necessary to expand the drive capability of the components such as when utilising a long bus with high capacitive loading. Note that the peripheral lines from side B are used for the converter bus since these present a high impedance when programmed as inputs. Also the 6821 PIA is preferred to the 6820 because this has a 2-TTL drive capability on both A and B side peripheral lines. As stated previously up to 4 ZN427 EOC outputs can be wire-or'd together; if using more than 4, then each group can be ANDED together using a ZN7409 TTL gate to produce a single interrupt line.

If required separate START signals can be generated for each ZN427 hence allowing a microprocessor read of one ADC to be in progress while the other(s) are in a conversion cycle. However this configuration does require one peripheral line and one 'D' type flip flop per START signal line. Since only one ZN427 or ZN428 should be enabled at any one time, then it is possible to incorporate one or more Decoder types of I.C. such as the ZN74154, 4 Line to 16 Line Demultiplexer/Decoder in order to expand the system. This device could be connected with the 4 data inputs connected to 4 PA peripheral lines and the decoder enable input driven by CA2 line. Use of two such IC's would provide 32 output lines allowing an Analogue I/O system with a combination of up to 32 analogue input and output channels to be produced.

As a result of the low converter cost, low external component count and flexibility of this type of system, designs based on using one converter per analogue channel will be both a practical and economical solution to microprocessor data acquisition problems. This approach should find many new applications in areas which have previously been limited by the necessity of having to use the traditional data acquisition methods involving a single, high cost hybrid A-D converter utilising sample hold and multichannel multiplexing techniques.

TABLE 1

MC6820	PA0 - PA7 / CA2	PB0 - PB7 / CB2	CA1/CB1
I_{LL} I_{HH} I_{OL} I_{OH}	-1.6mA max -100 μ A min 1.6mA min -100 μ A min)) 10 μ A max) 1.6mA min -100 μ A min) 2.5 μ A max) (at $V_{IN} = 0$ to 5.25V))
MC6821			
I_{LL} I_{HH} I_{OL} I_{OH}	-2.4mA max -200 μ A min 3.2mA min -200 μ A min)) 10 μ A max) 3.2mA min -200 μ A min) 2.5 μ A max) (at $V_{IN} = 0.5 \dots 5.25$ V))
ZN427			
I_{LL} I_{HH} I_{HH} (Clock) I_{OL} I_{OH} I_{OHX} (Off state leakage)	-5 μ A max 15 μ A max 30 μ A max 1.6mA min -100 μ A min 2 μ A max		
ZN428	All Inputs		
I_{LL} I_{HH}	-5 μ A max 20 μ A max		

NOTE Currents specified at 0.4 V and 2.4 V unless otherwise stated.

Interfacing the ZN 427 A to D Converter with the 8085A Microprocessor System

by SCOTT BIRD, Ferranti Electronics Ltd.

The growth of microprocessors has lead to a demand for low cost, fast 8 bit A/D and D/A converters to interface between the real world of analogue values and the digital world of the microprocessor. Converter systems have, until recently, been mainly high cost, multiplexed, sample and hold systems usually built around a 12 bit A/D converter. The system described in this report is a low cost, expandable, one converter per channel system, based on the ZN427 8-bit A/D Converter interfaced directly to the I/O Ports of the 8155 2K bit static 'RAM', which forms part of the basic 8085A microprocessor system.

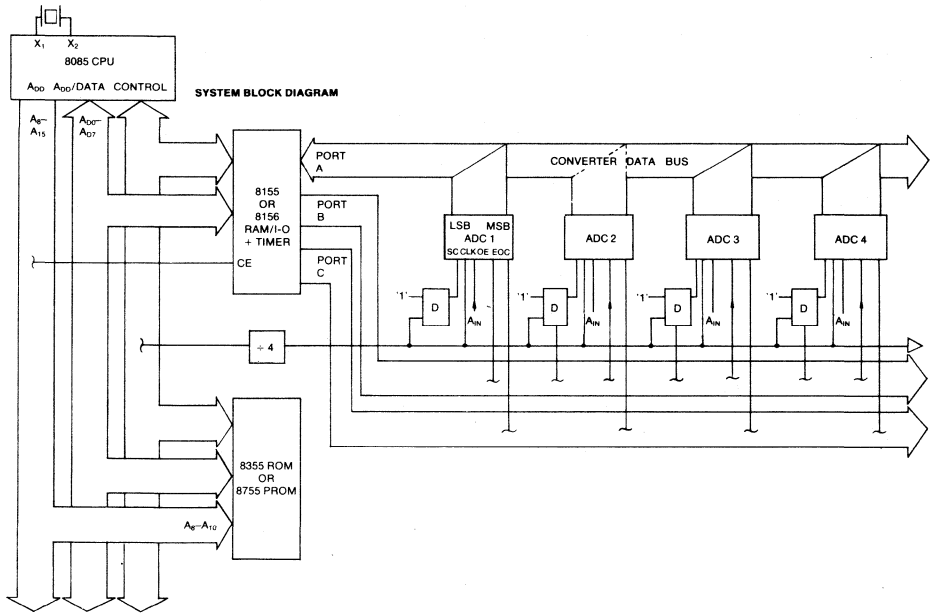

The ZN427 A/D Converter

The ZN427 is a monolithic 8-bit, successive approximation A/D Converter designed for microprocessor compatibility. It features fast 15 μ s conversion time, three-state outputs to permit bussing on common data lines and no missing codes over the full operating temperature range. The ZN427 contains a voltage switching D/A converter, a 2.5 V precision band gap reference, a fast comparator, successive approximation logic, and three-state output buffers.

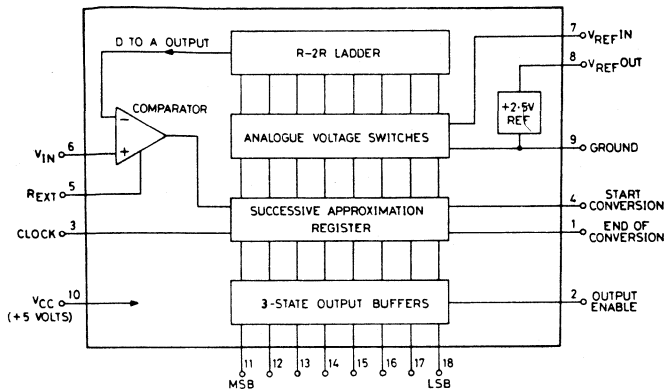

Fig. 2—ZN427 Logic Diagram

Operation of the ZN427 is best described with reference to the timing diagram.—Fig 3. Conversion is initiated by a Start Convert (SC) pulse which can be applied asynchronously with respect to the ZN427 clock providing the following criteria are met.

1. The leading edge of the SC-pulse should precede the first active (negative going) edge of the clock (after the trailing edge of the SC pulse) by at least 1.5 μ s to allow for MSB setting.
2. The trailing edge of the SC pulse must not occur within ± 200 ns of a negative going edge of the clock.
3. As a special case of conditions (1) and (2) the SC pulse may be coincident with, and of the same duration as, a negative going clock pulse.

Application of the SC pulse sets MSB to a '1' level and all other bits to a '0', which produces a voltage output from the D/A converter of $V_{REFIN} / 2$. This value is compared with the input voltage V_{IN} , and a decision is made on the first negative clock edge to set the MSB to '0' if $V_{REFIN} / 2 > V_{IN}$, or else to keep it at a '1'. Bit 2 is switched to a '1' on the same clock edge, and on the next edge a decision is made about bit 2, again by comparing the D/A output with V_{IN} . This process is

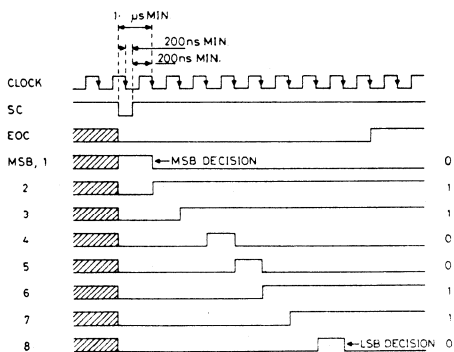

Fig. 3—Timing Diagram

repeated for all eight bits so that when the END OF CONVERSION (EOC) output goes high the digital output from the converter is valid representation of V_{IN} . The binary output is latched until the next START pulse. The three-state data outputs are OFF (high impedance) when OUTPUT ENABLE (OE) is a '0' and are enabled when the OE input is taken to a '1'.

The 8085A Microprocessor System

It is assumed that the reader is totally familiar with the 8085A microprocessor system, information on which can be obtained from the MCS-85 USERS MANUAL, so only a brief description is given here.

The 8085A is a complete 8-bit parallel central processing unit. A minimum component 8085 microcomputer system can be built from just three chips—the 8085A CPU, a 8355 or 8755 ROM or PROM, and a 8155 or 8156 RAM/TIMER/I-O chip. The 8155/8156 provides, in addition to 2k bits of Static RAM, two programmable 8-bit I/O Ports, one programmable 6-bit I/O Port and a programmable 14-bit binary timer counter. (The difference between the 8155 and the 8156 is that on the 8155 the CHIP ENABLE is active LOW, and on the 8156 it is active HIGH.)

The ZN427 Interface

This application note describes how up to 4, ZN427 ADCS can be connected to the I/O Ports of one 8155 RAM to provide 4 Analogue Input Channels to the microprocessor system. Since most 8085 based systems including the SDK-85 System Design Kit will incorporate one or more 8155s, then the addition of Analogue Input Channels would involve minimum additional hardware and design effort. An advantage of using the 8155 I/O Ports is that no additional address decoding or bus demultiplexing and buffering hardware is necessary.

For existing systems, if spare I/O Ports are available then analogue inputs can easily be added without any major modifications to the hardware. Also the expansion of the number of input channels to a system by addition of extra 8155s should be easily implemented since this device is directly bus compatible with the 8085A.

The 8155 I/O Ports are allocated as shown in the Logic Diagram, Fig. 1. Port A is programmed as INPUTS and provides an 8-bit data bus which connects to the three-state binary data outputs of each ZN427. Port B is programmed as OUTPUTS, the lower 4-bits provide the start convert and the upper 4-bits provide the Output Enable Signals to each ZN427. The END OF CONVERT output of each ZN427 is connected to a Port C pin, which are programmed as INPUTS to provide the individual BUSY FLAGS for each ZN427. Note that only 4- of the 6-bits available from Port C are used.

The ZN427 clock can be supplied either from an external source or from the 8085A CLOCK OUTPUT. Since the 8085A clock will normally be at 3 MHz, it will be necessary to divide this down by at least a factor of 4. This is achieved in the circuit, see Fig. 4, by means of a dual JK Flip Flop (7473) connected as a 2-bit binary counter. (Note: This will provide a clock frequency of 750 kHz which is a little higher than the ZN427 clock frequency spec. minimum of 600 kHz. However, for most practical applications the loss in accuracy due to this will be minimal.) An external clock could be used for the ZN427 but the advantage of using the microprocessor clock is that it allows an accurate calculation of the ZN427 conversion time to be made in terms of the microprocessor CLOCK CYCLES (or 'T' STATES).

(Note: To avoid confusion, future reference to 'clock' will mean the ZN427 clock signal unless specifically stated otherwise.)

The START CONVERT pulse is generated using a 'D' type Flip Flop ($1/2$ 7474) in order to meet the timing requirements discussed earlier. A conversion cycle is started by outputting a '0' followed by a '1' from the appropriate Port B output to the CLEAR input of the 'D' type which sets the SC input of the ZN427 to '0'. The first positive going clock edge after the CLEAR input is returned to a '1' clocks the 'D' type and sets the SC input to '1'. This sequence is illustrated in the Start Pulse Timing Diagram, Fig. 5.

On the 9th negative clock edge after the Start Pulse the END OF CONVERT output goes to a '1' signifying the end of the conversion process, this can be detected by an I/O read on Port C. However, when generating the ZN427 clock from the microprocessor clock as shown, the EOC output will always occur within 35 microprocessor clock cycles after the OUT instruction returning the SC input to a '1'. In this case it is not

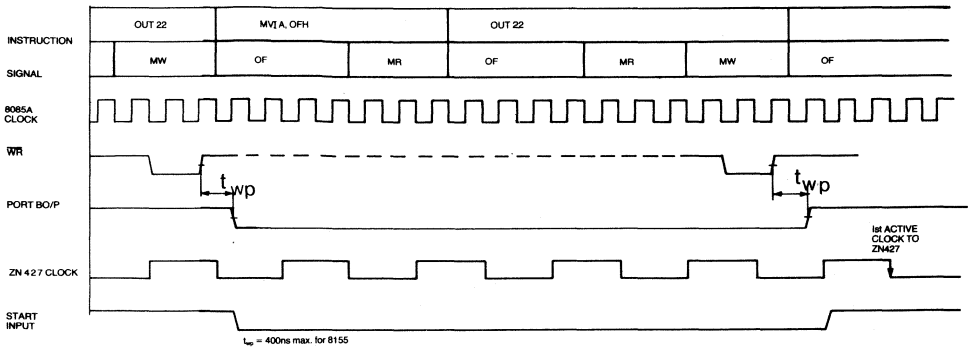

FIG. 5 START PULSE TIMING DIAGRAM

necessary to poll the EOC outputs, the ZN427 data outputs can be read after a suitable fixed delay in the programme. For application where processor time is at a premium or if immediate response is required to an EOC output, a microprocessor interrupt can be generated by connecting the EOC output direct to one of the 8085A restart inputs. The EOC outputs of to 4-ZN427s can be 'wire-OR'd' to produce a common interrupt line. Usually, however, the fast conversion time of the ZN427 (15 μs) will make it not worthwhile to employ microprocessor interrupts since the conversion time takes less than 6/7 typical microprocessor instructions.

The binary output data is applied via the converter data bus to Port A of the 8155 by driving the OE output to a '1' from the appropriate Port B bit. Obviously the programme should be arranged so that the outputs of only one ZN427 are enabled at any one time, in order to avoid bus contention problems. Note that in this application the Output Enable and Disable switching times (which are specified at 250 ns max.), need not be considered since they are much less than the instruction execution times.

The circuit diagram, Fig. 4 shows the ZN427s connected for a unipolar input range of 0 to +10 V. Other ranges, e.g. +5 V, ± 10 V, and ± 5 V can be readily obtained by using the appropriate resistors as shown in the ZN427 data sheet. Note also that the reference, $V_{\text{REF IN}}$, of up to five ZN427s may be driven from one internal reference. This useful feature saves power, discrete components, and gives excellent gain tracking between the converters.

In the circuit the negative supply to the ZN427s is through an 82K resistor from -5 V. By suitable choice of resistor any negative supply of -3 to -30 volts may be used. For applications where only a positive 5 volt supply is available, a simple diode pump circuit suitable for up to 5-ZN427s is shown in the ZN427 data sheet.

Programme Example

A simple programme is given on page 9 together with the flow diagram in Fig. 6, which illustrates the ease of controlling and reading the ZN427 with the 8155 I/O Ports.

Following the flow diagram it is seen that after initialisation of the stack pointer the I/O Ports of the 8155 are defined—Ports A and C as INPUTS, Port B as OUTPUTS. A simultaneous START CONVERT pulse is sent to all the ADCs by outputting logic '0' followed by logic '1' to the lower 4-bits of Port B. The EOC outputs of the ADCs are then read via Port C and tested for a logic '1' to check if the conversion process has finished. The microprocessor will loop on this part of the programme until the EOC output of all the ADCs go to '1'. When this occurs the programme proceeds by enabling the outputs of each ADC in turn and reading the binary data via Port A. The ADC outputs are enabled in turn by outputting a logic '1' to each of the upper 4-bits of Port B (keeping the other 3-bits at '0' and the lower 4-bits at a '1'). The data from each ADC is stored in consecutive memory locations, starting at the address labelled 'DATA'. The H and L register pair hold the memory address at which data is to be saved; these are incremented for each read of an ADC.

This programme could easily be modified to act as a sub-routine for another main programme. As mentioned previously a fixed delay could be substituted for the programme loop which tests the EOC outputs. Also instead of generating a simultaneous START pulse separate START signals may be sent to each ADC at different times in a control cycle.

Summary

The system described in this report should be suitable for most applications since it allows complete control of each individual ADC. However, the configuration can easily be changed for particular requirements,—a few ideas are briefly described below.

1. If a simultaneous START pulse is adequate, then the START CONVERT inputs of the ZN427s can be commoned together and driven via one 'D' type from one Port output.
2. The EOC outputs of up to 4-ZN427s can be commoned and either taken to one Port input or used as a microprocessor interrupt signal.
3. Adoption of methods 1 and/or 2 above would use less 8155 Port bits and hence allow more ZN427s to be connected to each 8155.
4. Instead of generating the START pulse from the 8155 it could be asynchronously produced externally by a process timer, photo transistor or proximity detector circuit etc., the only timing requirement being that the pulse width fed to the CLEAR input of the 'D' type is at least half a clock period. (i.e. 640 ns with a 320 ns microprocessor clock) or 1.5 μ s, whichever is smaller.
5. If D/A channels as well as A/D are required in one system then ZN428, 8-bit D/A Converters can be mixed on the same converter data bus as the ZN427. This will allow a designer to tailor a system to his specific A/D and D/A requirements. (See FERRANTI APPLICATION NOTE ANO11 for details of interfacing the ZN428 to the 8155.)

It is hoped that after reading this application note, the reader will have a much better insight into the operation and versatility of the ZN427, and into how it can easily be interfaced to a microprocessor system.

In order to avoid duplication only the relevant ZN427 characteristics were discussed in this report. For a full description and specification of the ZN427 please refer to the data sheet.

FIG. 6 PROGRAMME FLOW DIAGRAM

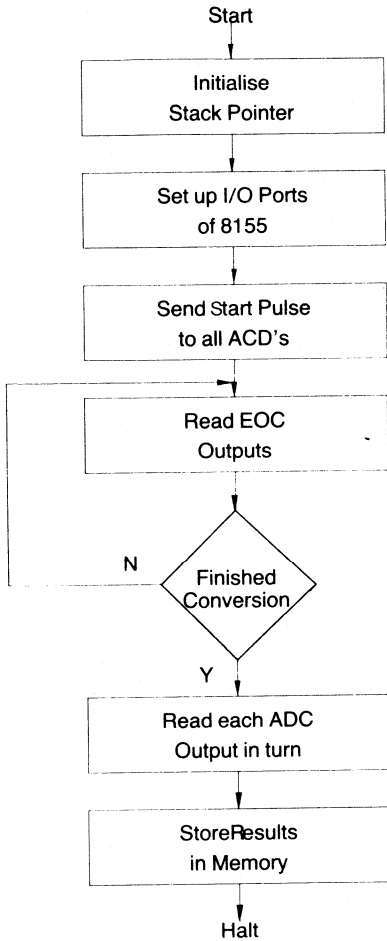

8155 PORT ALLOCATIONS

PORT A

PA0 Binary Data LSB
PA1 Binary Data LSB + 1

PA6 Binary Data MSB - 1
PA7 Binary Data MSB

PORT B

PB0 ADC1 SC Input
PB1 ADC2 SC Input
PB2 ADC3 SC Input
PB3 ADC4 SC Input
PB4 ADC1 OE Input
PB5 ADC2 OE Input
PB6 ADC3 OE Input
PB7 ADC4 OE Input

PORT C

PC0 ADC1 EOC Output
PC1 ADC2 EOC Output
PC2 ADC3 EOC Output
PC3 ADC4 EOC Output

I/O PORT ADDRESSES

20 Command/Status Reg
21 RAM Port A
22 RAM Port B
23 RAM Port C

ZN427 – 8085A PROGRAMME EXAMPLE

LOC	OBJ	SOURCE STATEMENT
2000	31C820	LXI SP, 20C8 Initialise Stack Pointer
2003	3E02	MVI A, 02H Define I/O Ports
2005	D320	OUT 20
2007	3E00	MVI A, 00H
2009	D322	OUT 22 Send Start To All ACD s
200B	3E0F	MVI A, 0FH
200D	D322	OUT 22
200F	060F	MVI B 0FH
2011	DB23	LOOP: IN 23 Read EOC s
2013	AO	ANA B Strip Upper 4 Bits
2014	B8	CMP B Test If All EOC s
2015	C21720	JNZ LOOP Are A '1'
2018	213B20	LXI H, DATA
201B	3E1F	MVI A, 1FH
201D	D322	OUT 22 Enable ADC 1
201F	DB21	IN21 Read ADC 1
2021	77	MOV M, A Save In Loc, DATA
2022	23	INX H Increment Pointer
2023	3E2F	MVI A 2FH
2025	D322	OUT 22
2027	DB21	IN21 Read ADC 2
2029	77	MOV M, A Save In LOC. DATA + 1
202A	23	INX H
202B	3E4F	MVI A 4FH
202D	D322	OUT 22
202F	DB21	IN 21 Read ADC 3
2031	77	MOV M, A Save In Loc DATA + 2
2032	23	INX H
2033	3E8F	MVI A 8 FH
2035	D322	OUT 22
2037	DB 21	IN 21 Read ADC 4
2039	77	MOV M, A Save In Loc. DATA + 4
203A	76	HLT
203B		DATA:
203C		
203D		
203E		

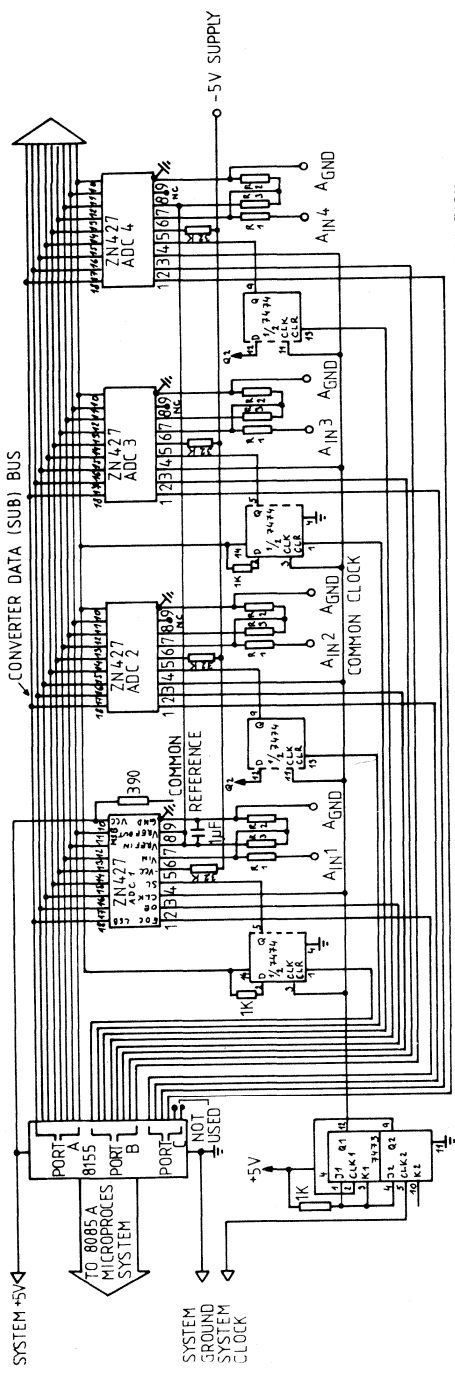

NOTE: FOR 10V UNIPOLAR OPERATION
 R1 = 10K POT + 11K IN SERIES
 R2 = 5K6
 R3 = 1M Ω POT + 680K IN SERIES

Interfacing the ZN 428 D to A Converter with the 8085A Microprocessor System

by SCOTT BIRD, Ferranti Electronics Ltd.

The growth of the microprocessor has led to a demand for low cost, 8-bit A/D and D/A converters to interface between the real world of Analogue values and the Digital world of the microprocessor. This report values a simple, low cost, expandable multichannel D/A system based on the ZN428, 8-bit D/A converter interfaced directly to the I/O Ports of the 8155, 2K bit static RAM, which forms part of the basic 8085 microprocessor system.

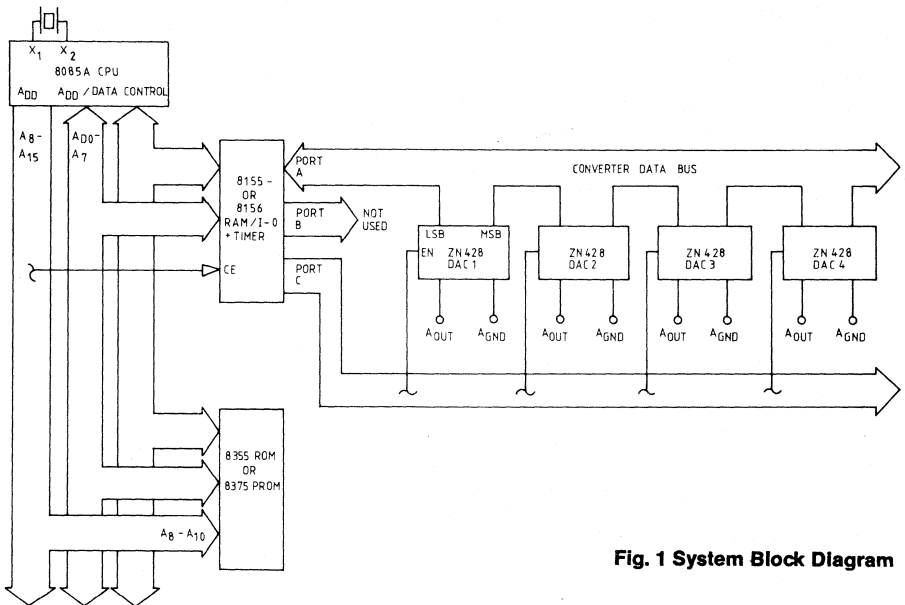

Fig. 1 System Block Diagram

The ZN428 D/A Converter

The ZN428 is a monolithic 8-bit D/A converter with input latches to facilitate updating from a data bus. The latch is transparent when ENABLE is at logic '0' and the data is held when ENABLE is taken to logic '1'. The ZN428 features single +5 volt supply requirements, fast 800 ns setting time and is guaranteed monotonic over the full operating range. It also contains a 2.5 volt reference the use of which is pin optional to retain flexibility. An external fixed or varying reference may therefore be substituted.

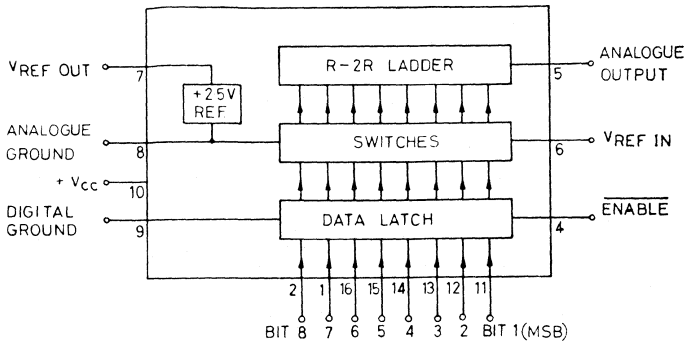

Fig. 2 ZN428 Logic Diagram

The converter is of the voltage switching type and uses an R-2R ladder network. Each 2R element is connected to 0 volt or $V_{ref IN}$ by transistor voltage switches specially designed for low offset voltage (1 millivolt). A binary weighted voltage is produced at the output of the R-2R ladder network the nominal output range of the ZN428 being 0 volt to $V_{ref IN}$ through a 4 k Ω resistance. Other output ranges can readily be obtained by using an external amplifier.

The 8085A Microprocessor System

It is assumed that the reader is totally familiar with the 8085A microprocessor system, information on which can be obtained from the MCS-85 USERS MANUAL; so only a brief description is given here.

The 8085A is a complete 8-bit, parallel central processing unit. A minimum component 8085A microcomputer system can be built from just three I.C.s—the 8085A CPU, an 8355 or 8755 ROM or PROM, and a 8155 or 8755 RAM/TIMER/I-O I.C. The 8155/8156 in addition to 2K Bits of Static RAM, provides two programmable 8-bit I/O Ports, one programmable 6-bit I/O Port and a programmable 14-bit binary timer counter. (The difference between the 8155 and 8156 is simply that on the 8155 the CHIP ENABLE is active LOW and on the 8156 it is active HIGH.)

The ZN428 Interface

This application report describes how one or more ZN428 DACs can be connected directly to the I/O Ports of an 8155 RAM to provide analogue output channels from the microprocessor system.

Since most 8085 based systems, including the SDK-85 System Design Kit, will incorporate one or more 8155s then the addition of Analogue output channels can be made with the minimum of extra hardware and design effort. An advantage of using the 8155 I/O Ports is that no additional address decoding or bus multiplexing and buffering hardware is necessary. For existing systems, if spare I/O Ports are available then analogue outputs can easily be added without major modifications to the hardware.

Also expanding the number of output channels by means of addition of extra 8155s should be easy to implement, since the 8155 is directly bus compatible with the 8085A. Figure 3 shows 4-ZN428s connected to the I/O Ports of one 8155. Port A is programmed as OUTPUTS and provides a common 8-bit data bus which is connected to the binary data inputs of each ZN428. The ENABLE inputs of each ZN428 are connected to separate pins on Port C which is also programmed as OUTPUTS. Note that in this configuration only 4 of the 6 Port C pins are used and Port B is also unused.

The reference voltage of all converters is provided by connecting the VREF OUT pin of one ZN428 to the VREF IN pins of all the ZN428s as shown. This useful feature saves power, components and gives excellent gain tracking between converters. Up to five ZN428s may be driven from one internal reference in this way.

The circuit, Fig. 3, shows the outputs of the ZN428s taken directly from pins 5 and 8. This will provide an output range of 0 volt to VREFIN through a 4 kΩ output resistance. A small capacitor can be connected across the output pins as shown in order to remove any "glitches" which may be present. The value of this capacitor depends on the noise in the system and the response time required, however, for the minimum settling time it should not be greater than 100 pF. The output buffer amplifier was omitted from the ZN428 in order to allow greatest system speed, flexibility and lowest cost. Both Unipolar and Bipolar output ranges can readily be obtained by using an external amplifier, details of which are given in the ZN428 data sheet.

The ZN428 is provided with separate Analogue and Digital ground pins. These can be connected together close to the I.C. pins. However, for noisy systems or environments it may be better to keep the Analogue ground pins for each individual ZN428 separate from the Digital ground, and to connect each Analogue ground to a single common earth point in the system, away from sources of digital noise such as clock oscillators, digital buses etc. The Analogue ground output line or terminals should also be taken direct to this common earth point. (Note: The maximum voltage between Analogue and Digital grounds is limited to 200 mV.)

Data is fed to a converter simply by outputting the binary data onto the common bus from Port A of the 8155. The appropriate output from Port C is then driven to a logic '0' level then back to a logic '1'. This will transfer the binary data on the bus into the input latches of the ZN428. The ENABLE inputs of converters which are not being updated are held at logic '1'. The data from Port A can now be changed and the next converter updated as and when required as determined by the controlling programme of the microprocessor. Note that in this application the Data Set-up and Data Hold times and Enable pulse widths need not be considered since they are much less than the microprocessor instruction execution times.

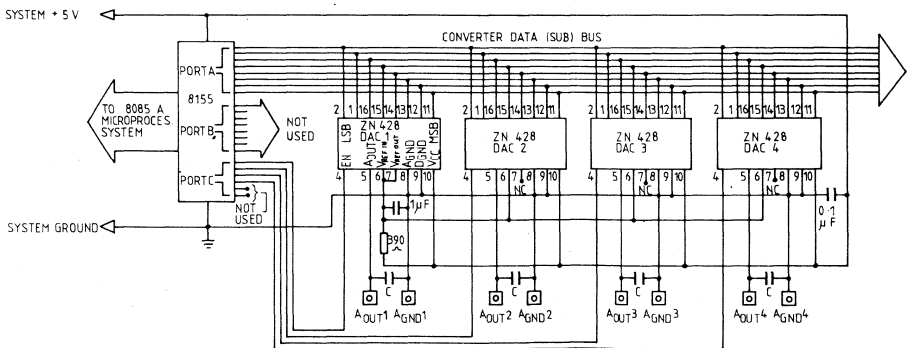

NOTE: FOR VALUE OF C PLEASE REFER TO TEXT

Programme Example

A simple programme is given on page 6 together with the flow diagram in Fig. 4, which illustrates the ease of controlling the ZN428 in conjunction with the 8155 I/O Ports.

The object of the programme is to read the binary data from four successive memory locations and to output this data sequentially to each of the four DACs. In practice this programme would probably act as a sub-routine outputting data derived from some external source and operated on by the main programme.

With reference to the flow diagram Fig. 5 it is seen that after initialisation of the stack pointer the I/O Ports A and C are defined as OUTPUTS. The H and L register pair are loaded with the starting address in memory of where the data to be outputted is stored. Register B determines which DAC is to be enabled, this is set initially to 11 111 110; while Register C, which acts as a loop counter is set to 4. Data is then read from memory into the Accumulator using the H and L registers in the Register Indirect addressing mode. This data is outputted onto the converter data bus via Port A by sending the contents of the Accumulator directly to the 8155 with the 'OUT' instruction. DAC 1 is now enabled by transferring the contents of Register B to the Accumulator and outputting this via Port C. The Accumulator contents are rotated one bit left before being transferred back to Register B, ready to enable the next DAC. Next ENABLE is removed by outputting all 1's via Port C, H and L are incremented to address the next data byte and Register C is decremented and tested for zero. In this case Register C will contain 03 and the programme will branch back to the address labelled 'LOOP' via a conditional jump instruction, and the next data byte will be read into the Accumulator. Since Register B was shifted one bit left the new data will be loaded into DAC 2 on this cycle of the loop. The programme cycles round the loop 4 times, reading the data from memory and outputting it to each DAC in turn until Register C is decremented to zero, at which point the programme halts.

ZN428 - 8085A PROGRAMME EXAMPLE

LOC	OBJ	SOURCE STATEMENT	COMMENT
2000	31C820	LXI SP, 20C8	Initialise SP
2003	3E0D	MVI A, 0D	Define I/O Ports
2005	D320	OUT 20	
2007	212020	LXI H, DATA	Set H & L = Data
200 A	06FE	MVI B, FEH	
200 C	0E04	MVI C, 04H	
200 E	7E	LOOP: MOV A, M	Read Data
200 F	D321	OUT 21	Put Data on Bus
2011	78	MOV A, B	
2012	D323	OUT 23	Set Enable low
2014	07	RLC	Rotate left for next DAC
2015	47	MOV B, A	
2016	3EFF	MVI A, FF	Set Enable high
2018	D323	OUT 23	
201A	23	INX H	
201B	0D	DCR C	
201C	C2 0E 20	JNZ Loop	Jump if C = 0
201F	76	HLT	
2020	-	DATA :	
2021			
2022			
2023			

FIG. 4 PROGRAMME FLOW DIAGRAM

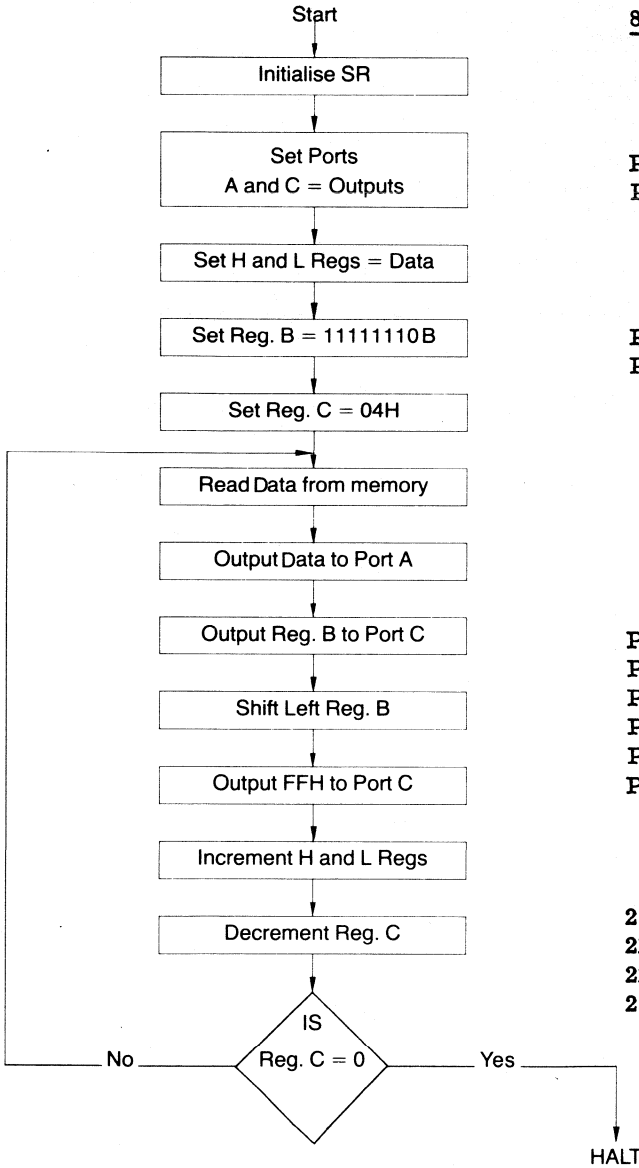

8155 PORT ALLOCATIONS

PORT A

PA0 Binary Data LSB
PA1 Binary Data LSB + 1

PA6 Binary Data MSB - 1
PA7 Binary Data MSB

PORT B

NOT USED

PORT C

PC0 DAC1 Enable Input
PC1 DAC2 Enable Input
PC2 DAC3 Enable Input
PC3 DAC4 Enable Input
PC4 Not Used
PC5 Not Used

I/O PORT ADDRESSES

20 Command/Status Reg
21 RAM Port A
22 RAM Port B
23 RAM Port C

Summary

The system described in this report should be satisfactory for most applications, however, this configuration is by no means rigid, but is only intended as one example to demonstrate how easily the ZN428 can be used with the 8085A microprocessor system. A few ideas and notes are briefly described below, and it is hoped that these will help the Design Engineer to produce the most efficient system for his particular requirements.

1. The 8155 I/O Ports can be allocated as dictated by system requirements and availability. In the example all of Port A and four of the six Port C I/O pins are used. Port B could have been used equally as well either for the converter data bus or to provide the ENABLE signals.
2. If I/O Port pins are limited and only one DAC needs to be enabled at any one time, then a Decoder I.C. (i.e. 8205, 1 out of 8 binary decoder) can be used to drive the ENABLE inputs. For Example 4 I/O Port pins, 3 for the address code and 1 for the decoder enable would drive 8 DAC ENABLE inputs.
3. In order to update 2 DACs simultaneously but with different data, then the binary inputs of one (or more) DACs could be connected to Port A and the other DAC to Port B. The relevant data could then be outputted on Ports A and B and then the ENABLE inputs of both DACs driven to logic '0' together, either by commoning the two inputs to one Port C pin or by using separate I/O pins from Port C but programming both bits to go low together.
4. The number of ZN428s which can be connected to a common data bus is limited only by the bus capacitance and the drive capability of the 8155 I/O Ports. Note the low inputs currents of the ZN428—
 $I_{IH} = 20 \mu A$ at 2.4 V, $I_{IL} = -5 \mu A$ at 400 mV.
5. When the ZN428 ENABLE input is held at logic '0' the input latches are held open and the data is transferred directly to the ladder switches. Therefore, if repeatedly updating only one DAC the ENABLE input can be held at logic '0' instead of returning to logic '1' after each update.
6. If A/D channels as well as D/A are required in one system, then ZN427, 8-bit A/D Converters can be mixed on the same converter data bus as the ZN428. This will allow the design engineer to tailor a system to his specific A/D and D/A requirements. (See FERRANTI APPLICATION NOTE AN 010/OSB for details of interfacing the ZN427 to the 8155.)

It is hoped that after reading this application note the reader will have a much better insight into the operation and versatility of the ZN428, and into how it can easily be interfaced to a microprocessor system. In order to avoid duplication only the relevant characteristics of the ZN428 were discussed in this report. For a full description and specification of the ZN428 please refer to the data sheet.

Direct Bus Interfacing Using The ZN427/ZN428 Data Converters

INTRODUCTION

The rapid growth of the microprocessor coupled with its diminishing cost has opened up many potentially new applications in the measurement, control and data acquisition fields of the electronics industry. This growth has, however, been so fast that a vacuum has been created in the data conversion market for low cost, microprocessor compatible converters which can interface the digital microprocessor with the real analogue world. Without some form of interface to the outside world a microprocessor is simply a non-entity. No matter how powerful and fast the microprocessor itself is, if it cannot communicate efficiently with the world around it then its usefulness is limited and its power wasted. It is to meet this requirement that two fast, low-cost, microprocessor compatible data converters have been introduced by Ferranti Electronics Ltd. This application note introduces these two converters and describes how they can easily be interfaced directly to most of the popular types of microprocessor with particular reference to the 6800 and 8085A.

THE ZN427 A to D CONVERTER

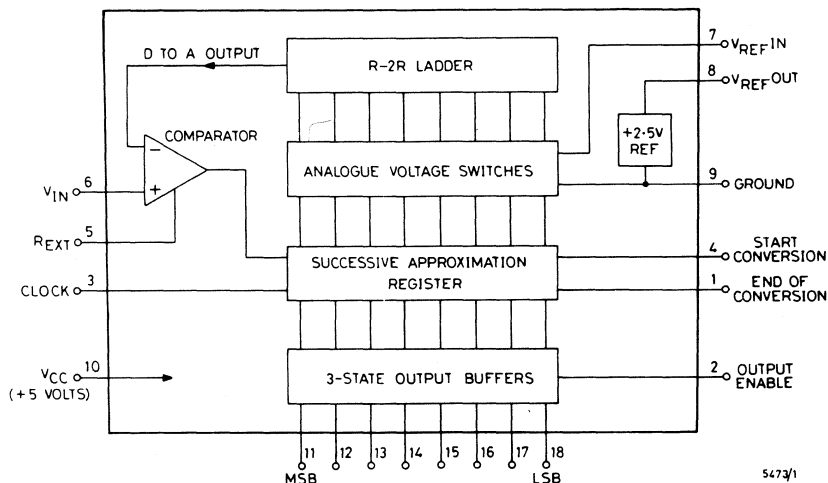

Fig. 1. ZN427 LOGIC DIAGRAM

The ZN427 is an 8-bit successive approximation A to D converter (ADC).

It features 3-state output buffers to permit bussing on to common data lines, fast $15 \mu\text{s}$ conversion time and no missing codes over its full operating temperature range. The ZN427 contains a voltage switching D to A converter, a fast comparator, successive approximation logic, three-state output buffers and a 2.5 volt precision band-gap reference.

The use of the on chip reference is pin optional to retain flexibility, an external fixed or varying reference for ratiometric operation may, therefore, be substituted. Only a few passive external components are required. For basic operation these are an input resistor, a reference current resistor and stabilising capacitor, and a resistor from the R_{EXT} pin 5 to the negative supply rail.

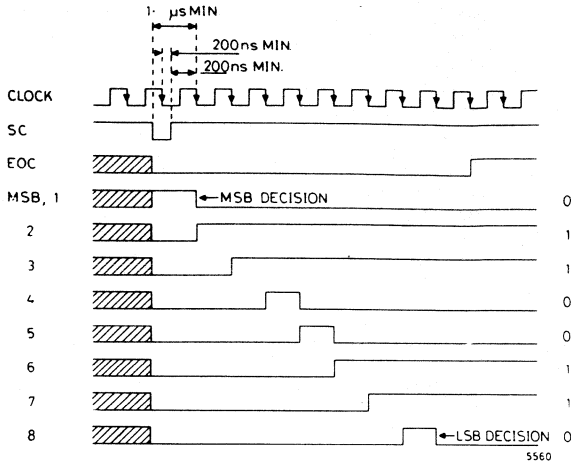

Fig. 2. ZN427 TIMING DIAGRAM

The conversion cycle is initiated by a negative going pulse applied to the START CONVERSION (SC) input, this sets the END OF CONVERSION (EOC) output to a logic '0' indicating that the converter is busy, see Fig. 2. On the ninth negative clock edge after the start pulse the EOC output goes back to a logic '1' signalling that the cycle is complete. The binary output data is latched until the next start pulse. The three-state data outputs are switched OFF (high impedance state) when the OUTPUT ENABLE (OE) input is at a logic '0' and they are enabled when the OE input is taken to a logic '1'.

THE ZN428 D to A CONVERTER

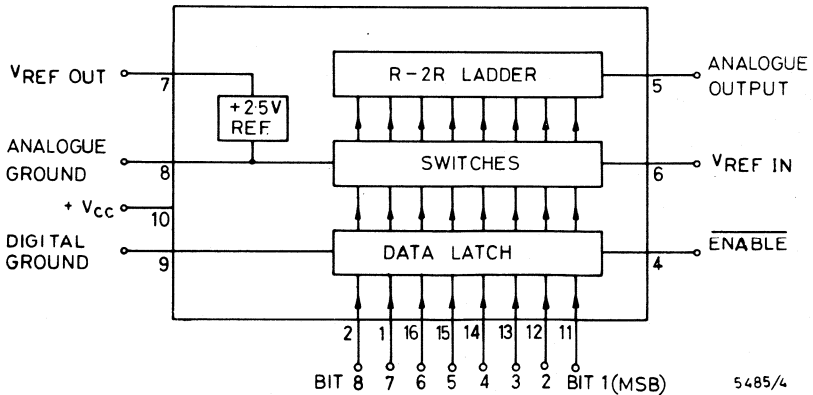

Fig. 3. ZN428 LOGIC DIAGRAM

The ZN428 is a monolithic 8-bit D to A converter (DAC), with input latches to facilitate updating from a microprocessor data bus. The latch is transparent when the ENABLE (EN) input is at a logic '0' and the data is held when EN is taken to a logic '1'.

The ZN428 features single +5V supply requirements, fast 800 ns settling time and is guaranteed monotonic over its full temperature range. It contains a pin optional 2.5V precision band-gap reference identical to the ZN427. The converter is of the voltage switching type and uses an R-2R ladder network. Each 2R element is connected to 0 volt or $V_{REF IN}$ by transistor logic switches especially designed for low offset voltage (<1 millivolt). A binary weighted voltage is produced at the output of the R-2R ladder network, the nominal range being $0 - V_{REF IN}$ volts with a 4 kΩ resistance. Other output ranges can readily be obtained by the use of an external amplifier allowing complete versatility in its application.

THE ZN427 MICROPROCESSOR BUS INTERFACE

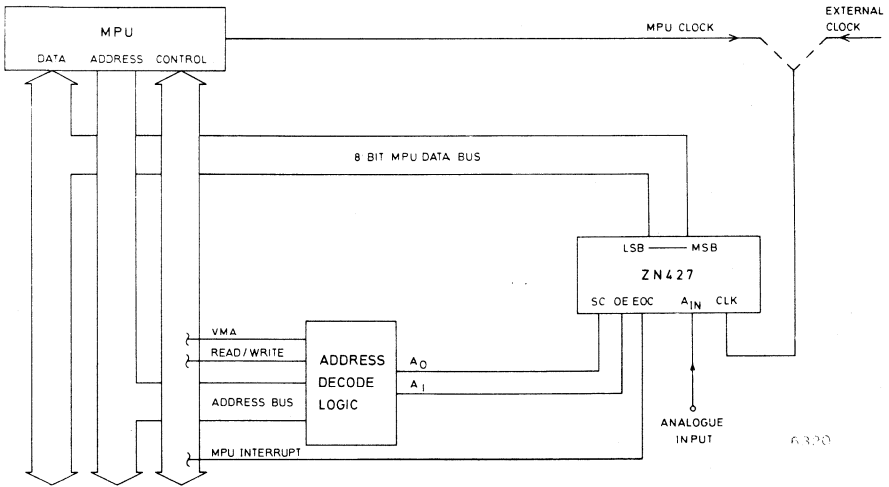

Fig. 4.

Peripheral devices can be connected to a microprocessor system by two basic methods. The first and usually the simplest from the point of view of design effort required is to use a Peripheral Interface I/O device usually found as a support IC in most of the MPU families. With this method the peripheral device is simply connected to the I/O lines of the Peripheral Interface device and generally no considerations have to be made in terms of bus buffering, bus timing or address decoding.

The second method is to connect the peripheral device directly to the microprocessor data bus. This method is termed "Memory Mapped I/O" which as its name implies is to make each peripheral I/O function appear to the MPU as a normal memory location, in which case the MPU cannot tell whether it is addressing memory or I/O. This allows the full set of memory reference instructions to be used for I/O data transfer, but it does imply that the peripheral device must be capable of responding at least as fast as the MPU memory and hence it should be compatible with the bus timing characteristics. The disadvantages of Memory Mapped I/O are that it usually requires additional address decoding logic, and also, since the I/O device will be addressed as memory, then there will consequently be fewer addresses available for actual memory.

It is with this second method of interfacing that this Application Note is primarily concerned. The Peripheral Interface I/O method of interfacing the ZN427 and ZN428 is covered in Application Notes AN010 – AN012.

A variation of Memory Mapped I/O, sometimes known as "I/O Mapped I/O" is available on some MPUs which overcomes the last disadvantage referred to. This allows a defined range of memory address also to be used for I/O by means of separate I/O instructions. A special control line is required to inform the memory and I/O device whether the address of the current READ or WRITE cycle refers to memory or to I/O. This technique however does restrict the freedom of the programmer to the use of these I/O instructions which normally only operate on data in the micro-processor accumulator.

Figure 4 shows the basic Memory Mapped interface for the ZN427 where the 8 binary outputs of the ADC are connected directly to the MPU data bus. The control inputs, START CONVERSION and OUTPUT ENABLE are shown driven from address decoder logic, the function of which is to drive the appropriate input when the address which has been allocated to that particular input is present on the address bus and the control bus signals indicate a valid memory read or write operation. Note that the level of address decode logic used must ensure that the three-state data outputs of the ZN427 are disabled at all times except when the actual ADC data is required on the data bus, otherwise bus contention problems may occur with other devices using the bus. The END OF CONVERSION output can be connected directly to an MPU interrupt input to signal the completion of the conversion cycle by the ADC. The ZN427 clock can be derived either from the MPU clock or from an external source. If however the former method is employed, it may simplify the design of the interface with regard to the timing criteria of the SC input. (This is covered in more detail later in this report).

THE ZN428 MICROPROCESSOR BUS INTERFACE

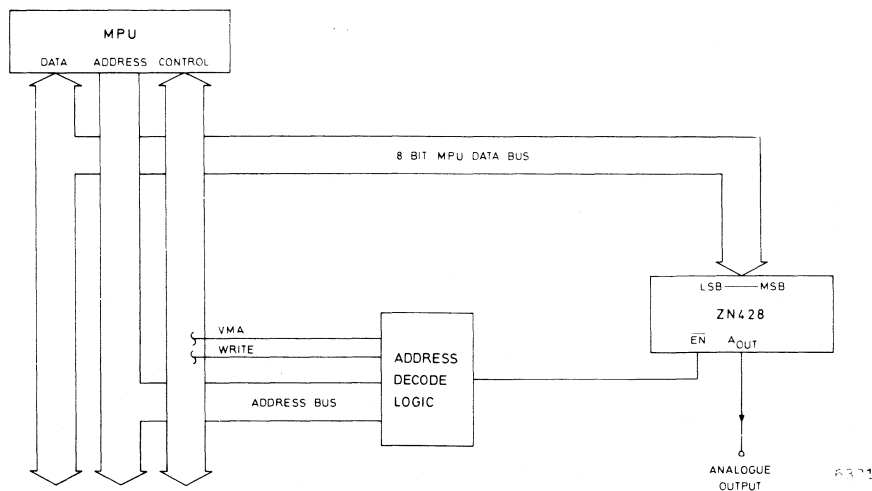

Fig. 5.

The ZN428 data inputs can be directly connected to an MPU data bus when used in the Memory Mapped configuration, this is illustrated in Fig. 5. For this application the address decode logic has only to generate the NOT ENABLE signal for the DAC. This is accomplished by gating the MPU

WRITE signal with the decoded address signal in order that when a memory write instruction to the DAC address location is executed, then a negative going pulse is applied to the EN input which will transfer the binary code from the data bus to the ZN428 input latches.

INTERFACING TO THE 6800 BUS

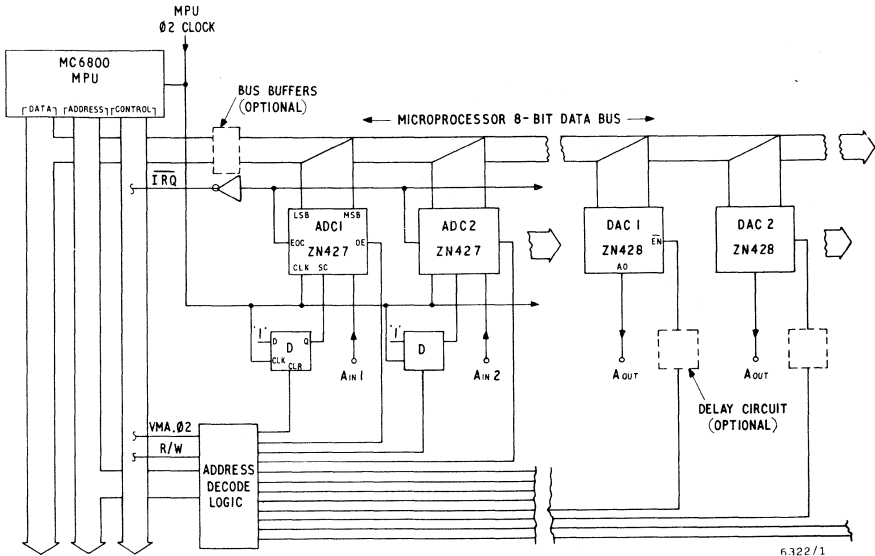

Fig. 6. ZN427/ZN428 TO 6800 BUS INTERFACE

With the ability of the ZN427 and ZN428 to be bus compatible it is possible to produce a complete Analogue I/O system, specifically configured to the designer's own requirements with the converters connected directly to the MPU data bus. Such a system is illustrated in figure 6 built around a 6800 MPU.

The 6800 is an 8-bit monolithic microprocessor which forms the central control function for the 6800 microprocessor family. Fully compatible with TTL logic the 6800 requires only a single +5 volt power supply, it features a set of 72 instructions with 7 addressing modes and full 65K byte memory addressing capability. The microprocessor communicates with its external memory and all I/O peripherals over an 8-bit bi-directional data bus and a 16-bit address bus. (Full data on the 6800 microprocessor is readily available from its manufacturers and their distributors).

The number of ZN427s and ZN428s which can be hung on the data bus is not limited, the only restrictions being the total load presented to the data bus and the number of decoded address lines available. The loading and drive characteristics of the converters are summarised in Table 1. Optional bi-directional bus buffers are shown in the diagram, these can be used to expand the system. Use of these will be dependent on the total number of converters used, other peripheral and memory devices on the data bus, and other loading factors such as the physical length of bus required.

ZN427		ZN428	
Parameter	Specification	Parameter	Specification
I_{IL}	-5 μ A max.	I_{IL}	-5 μ A max.
I_{IH}	15 μ A max.	I_{IH}	20 μ A max.
I_{IH} (Clock)	30 μ A max.		
I_{OL}	1.6 mA min.		
I_{OH}	-100 μ A min.		
I_{OHX} (Off state leakage)	2 μ A max.		

(NOTE: Currents specified at 0.4V and 2.4V).

TABLE 1. LOADING CHARACTERISTICS OF THE ZN427 and ZN428

The level of address decoding will depend on the overall MPU system design. This can range from merely using the upper address lines directly with no hardware decoding to provide the control lines for the converters – which rapidly depletes the number of address locations available for memory, through to full address decoding where all 65K addresses can be utilised. The address decode hardware can usually be produced from a few TTL gates in association with an Address Decoder I/C such as the ZN74154. In order to avoid addressing problems it is necessary on the 6800 to qualify the decoded address with the Valid Memory Address (VMA) and $\phi 2$ clock signals. The READ/WRITE control line can also be utilised to permit a single decoded address to control each ZN427, i.e. a WRITE instruction to the specific address would generate the SC signal and a READ instruction of the same address would enable the converter outputs and read the data. The function of the 'D' type flip flops shown in the diagram is to ensure that the timing criteria of the SC pulse are met. The requirements for this are that the SC pulse should start at least 1.5 μ s before the first active (negative going) clock edge after the SC pulse, and that the trailing edge of the SC pulse must not occur within ± 200 ns of a negative going clock edge, see figure 2. By careful design of the address decode logic when deriving the converter clock from the MPU it is possible to produce the correct timing for the SC pulse and to dispense with the 'D' type flip-flops.

The other advantage of using the MPU clock is that it allows an accurate calculation of the ZN427 conversion time to be made in terms of MPU machine cycles. Again with reference to figure 2 it can be seen that the conversion cycle always takes less than 10 clock cycles after the end of the SC pulse. Hence instead of using the EOC output to drive the MPU \overline{IRQ} input a simple programme delay loop can be substituted. Note that the EOC outputs of up to five ZN427s can be 'wire-anded' together to form a common interrupt line.

The clock frequency of the standard 6800 is 1 MHz which can be used directly to drive the ZN427s if a small loss of accuracy can be tolerated. The 6871B MPU clock generator is produced in a version with a 614.4 kHz clock signal. This is only marginally higher than the specified ZN427 clock rate of 600 kHz and the \varnothing 2 TTL output of this can be used directly for the converter clock if full accuracy is essential.

With the 6800 it may be necessary to delay the decoded address enable signal to the ZN428 converters if glitch free operation is desired. This is due to the fact that during a write operation on the 6800 the address and address qualifying control signals become valid before the data bus signals are valid, thereby enabling the DAC before the data is established on the data bus.

The Analogue output can be taken directly from the ZN428 output pin which provides a nominal output range from zero volts to $V_{REF IN}$ with a $4k\Omega$ output resistance. For most applications higher output ranges or drive will be required. This can easily be accomplished on the ZN428 by the addition of an external buffer amplifier which can be chosen for the specific characteristics required. The ZN428 is provided with separate Analogue and Digital ground pins which should normally be connected together close to the I.C. For noisy systems or environments an improvement may be obtained, in some cases, by running the two ground pins to supply ground separately, taking the Analogue ground of each ZN428 to a single common earth point in the system away from the sources of high noise such as clock oscillators, digital buses, etc. Note that the maximum voltage between the Analogue and Digital ground pins should not be allowed to exceed 200 mV.

Both the ZN427 and ZN428 contain a nominal 2.5V internal band-gap voltage reference. Use of this on-chip reference is pin optional to retain flexibility and an external reference can be substituted which allows ratiometric operation over the range of typically 1.5 to 3V. The on-chip reference is capable of supplying the reference voltage for up to five ZN427s and ZN428s. This useful feature saves power, discrete components and gives excellent gain tracking between the converters in a system. The tail current for the comparator on the ZN427 is derived via an external resistor from a negative supply. By suitable choice of resistor any negative supply of between -3 and -30 volts may be used. Since the negative current is only of the order of 65microamps per converter then for applications where only a positive supply is available a simple diode pump circuit can be used.

With a memory mapped interface the full range of memory reference instructions are available to the programmer in order to control the converters, and programming becomes a relatively simple matter of reading and writing data to the addresses allocated to the converters. For example, for the ADCs a conversion cycle could be initiated by a store accumulator command (STA A) to address location ALOC 1, where ALOC 1 is the address of the ADC to be accessed. The contents of the MPU accumulator 'A' at this time are irrelevant since we only want to generate a memory write cycle to produce a pulse at the SC input. Now one can either enable the MPU interrupt and wait for the EOC output to generate an interrupt request signal if this is the method used or alternatively a simple programme delay loop can be entered to produce a delay of ≥ 9 converter clock cycles (i.e. $\geq 15 \mu s$ if a 600 kHz clock is used). Upon receipt of an interrupt or completion of the delay a load accumulator command (LDA A) can be performed on address ALOC 1. This will read the binary data from the converter into the MPU accumulator 'A'. It is even simpler to programme the DACs. All one needs to do is to load the value to be outputted to say accumulator 'A' in binary format. A store accumulator command (STA A) is then programmed to address location ALOC 2, where ALOC 2 is the address allocated to the DAC. Upon execution of this the data will be transferred from the accumulator via the data bus to the DAC input latches, and be present at the DAC output in analogue form within 1.25 microseconds of the enable pulse.

INTERFACING TO THE 8085 BUS

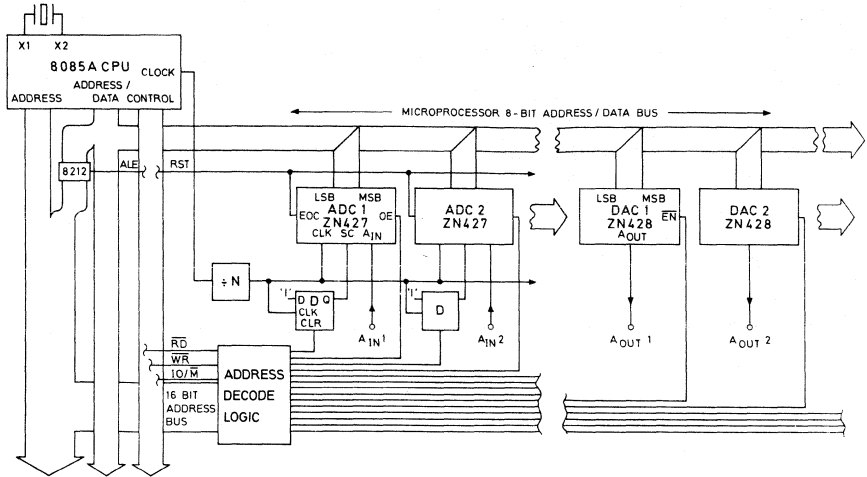

Fig. 7. ZN427/ZN428 TO 8085 BUS INTERFACE

An analogue I/O system for the 8085A microprocessor is shown in figure 7. This is similar to the 6800 system but the following exceptions should be noted.

The 8085A is another popular 8-bit microprocessor. However, unlike the 6800 this MPU uses a multiplexed data bus whereby the lower 8 address bits A0-A7 are time shared with the 8 data bits. The address bus contains the upper 8 bits A8-A15. If the lower 8 address bits are to be used for address decoding then it is preferable to de-multiplex the bus using an 8 bit latch, such as the 8212, strobed with the Address Latch Enable (ALE) signal from the MPU. The 8085A offers either Memory Mapped I/O or I/O Mapped I/O by means of a separate control line ($\overline{IO/\overline{M}}$). This allows use of the 'IN' and 'OUT' instructions to control I/O data transfers and the retention of the full 65K memory locations. If using this method then it is unnecessary to de-multiplex the Address/Data Bus, since only the lower 256 addresses are used for I/O transfers, and the address in the lower 8 bits is mirrored into the upper 8 address bits during this operation.

The standard 8085A clock frequency is 3 MHz. Hence it is necessary to divide the output from the 8085A CLK output pin down by a factor of at least 4 to produce an acceptable ZN427 clock. Because of this it is more difficult to synchronise the decoded address signals with the ZN427 clock in order to meet the start pulse timing criteria, and one will usually have to incorporate the 'D' type flip-flops as indicated to generate the SC pulse.

Note that with the 8085A the common EOC line can be used directly to generate an interrupt via one of the 3 Restart Interrupt inputs. The decoded address input to the ZN428s \overline{EN} input can also be used without any additional delay since, with this MPU the bus data is valid during the time that the WRITE signal is established.

Again programming is very straightforward. With a Memory Mapped I/O configuration the Data Transfer commands – Move (MOV), Load (LDA), and Store (STA) can be used to control data transfers between the converters and the MPU. If an I/O Mapped I/O configuration is adapted then the input (IN) and Output (OUT) commands are used to transfer data between the MPU accumulator and the converters.

SUMMARY

The Analogue I/O systems described in this report are intended only as a guide to illustrate to design engineers the ease and versatility with which these two converters can be used to produce analogue I/O channels for popular 8-bit microprocessors. As a result of the low cost, low external component count and flexibility of these converters, designs based on the 'one converter per channel concept' will be both a practical and economical solution to microprocessor data acquisition problems. This approach should find many new applications in areas which have previously been limited by the necessary usage of traditional data acquisition methods involving a single high cost hybrid ADC utilising sample and hold and multichannel multiplexing techniques.

Microprocessor Interfacing Using The ZN432 10-Bit Data Converter

INTRODUCTION

The use of Microprocessors in the fields of Process Control, Automotive applications, Industrial Data Acquisition and Logging and Domestic Consumer Products is becoming increasingly widespread. Indeed the fall in the price of the microprocessor itself is creating new applications in fields previously uneconomical to develop, and whilst the price of the microprocessor has fallen dramatically over the past two or three years the fall in the price of compatible Data Conversion products has not been so sharp. This is partially due to the fact that most Data Conversion products cannot be produced by using a single semiconductor process (as can microprocessors), but have to be manufactured in hybrid form using different processes for the digital and linear elements plus thin film technology and laser trimming for the precision resistor networks. Currently one may purchase a Microprocessor Integrated Circuit for only a few pounds whilst a microprocessor compatible Data Acquisition module may well cost in the region of £200. This module will of course probably provide 16 channels at 12 bit accuracy, but not every user wants all these channels or accuracy and though lower cost Converter I.C.'s are available the system manufacturer may well be disinclined to spend the time and manpower in designing a converter interface for his microprocessor system due to the complexities with which he fears he may be faced.

This Application Note describes a monolithic 10 bit accurate Analogue to Digital (A/D) Converter integrated circuit and explains the different techniques of interfacing this to common 8-bit microprocessors using the minimum of external discrete components and standard TTL logic elements.

THE ZN432 A/D CONVERTER

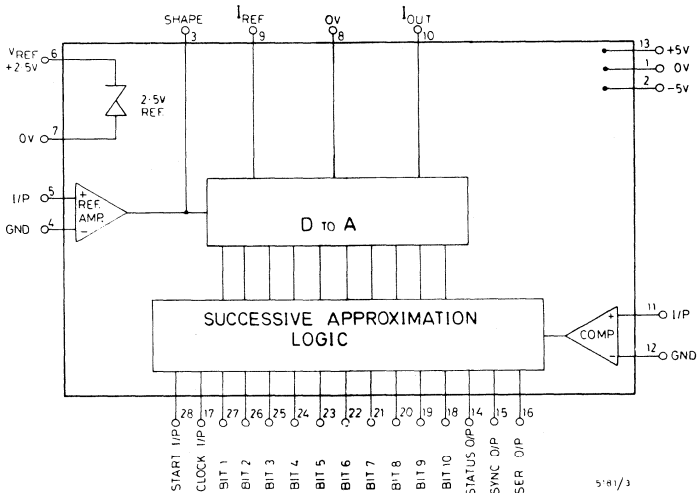

Fig. 1. ZN432 LOGIC DIAGRAM

The ZN432 is a 10-bit Analogue to Digital Converter produced in monolithic form by a silicon bipolar process. The converter is of the Successive Approximation type and includes an on-chip precision reference, reference amplifier, comparator, successive approximation logic and a D to A Converter. The D to A converter operates on the unit current source principle with a current switching

array using a matrix of diffused resistors. As a result of incorporating several design and layout innovations and the use of highly developed processing and photomask techniques, 10-bit accuracy is obtained without the need for post diffusion trimming operations. Only a few external components are required, including two capacitors, to shape the internal reference and reference amplifier outputs, and several resistors which define the input voltage range of the converter, which can be either unipolar or bipolar over whichever range is required by selecting suitable external resistors. The ZN432 is available in 3 temperature ranges, including full military temperature range, and in either 8 9 or full 10-bit accurate versions, packaged in a 28 lead hermetically sealed ceramic D.I.L. encapsulation.

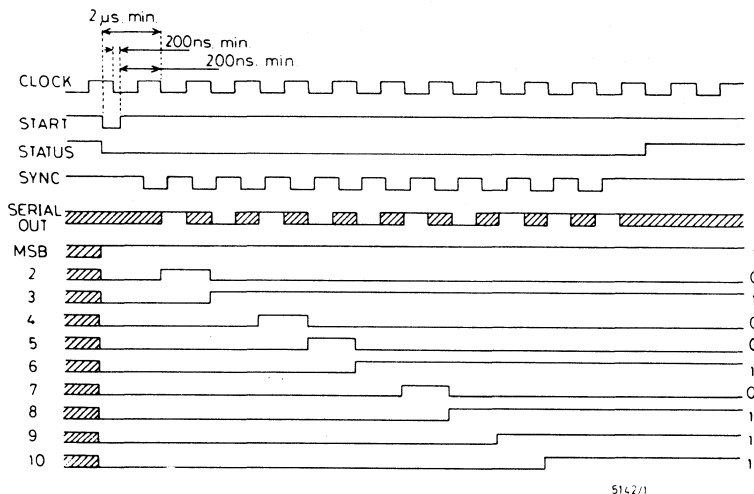

Fig. 2. TIMING DIAGRAM

The operation of the converter can best be described by reference to the timing diagram, Fig. 2. Conversion is initiated by a negative going START pulse which sets the MSB to a logic '1' and all other bits to a logic '0'. The STATUS output is also set to a logic '0' at this time indicating that the converter is busy. The leading edge of the START pulse should occur at least 2 μs before the 1st active negative going edge of the clock and the trailing edge of the START pulse must not occur within ±200 ns of a negative going clock edge. On the next negative going clock edge a decision is made on whether to set the MSB back to a logic '0' if the input current is less than the D to A output or, if not, it is left at a logic '1'. Bit 2 is switched to a logic '1' on the same clock edge and on the next negative edge a decision is made about Bit 2, again by comparing the input current with the internal D to A output. This process is repeated for all 10 bits so that when the STATUS output goes to a logic '1' on the 11th negative clock the digital output from the converter is a valid representation of V_{in} . A SERIAL DATA output is also provided on the ZN432, this data is outputted during the conversion cycle and is valid on the positive going edge of the pulses on the SYNC output.

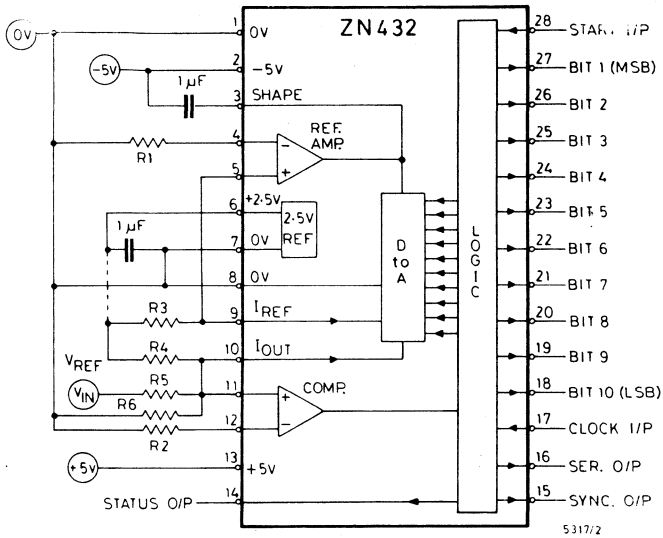

Fig. 3. TYPICAL EXTERNAL COMPONENTS

A diagram showing typical external components for the ZN432 is shown in Figure 3. The capacitor on pin 3 is used to stabilise the reference loop whilst that on pin 6 is for stabilisation and decoupling of the voltage reference output. Resistors R1 and R2 control the bias current of the reference amplifier and comparator, R3 defines the D to A reference current, R4 and R5 set the input voltage range and R6 is selected to obtain a suitable D to A time constant. For setting up, R3 will adjust the converter gain and R4 the offset. As an example, the resistor values for a ± 10 volt input range are:

- | | |
|----------------------|----------------------|
| R1 = 5 k Ω | R4 = 2.5 k Ω |
| R2 = 1.25 k Ω | R5 = 10 k Ω |
| R3 = 5 k Ω | R6 = 3.33 k Ω |

Resistors R3, R4 and R5 affect gain and offset and hence high stability types should be used whereas the nearest preferred values may be chosen for R1, R2 and R6. Refer to the ZN432 Series Data Sheet for more information on the selection of external components.

INTERFACING DATA CONVERTERS TO MICROPROCESSORS

Peripheral devices can be interfaced to microprocessor systems by two basic methods. The first and simplest is to use a general purpose I/O device, (also known as Peripheral Interface Adapters, Versatile Interface Adaptors or Programmable Peripheral Interfaces, etc.). Most microprocessor systems on the market usually include one or more of these components in their Microprocessor Systems Family. They normally consist of one or more data ports, usually of 8 bits which can be programmed to function either as inputs or outputs. With some devices the complete port has to be programmed to function either as all Inputs or all Outputs, but the more useful I/O devices allow the individual pins of each data port to be programmed separately as Inputs or Outputs. In addition most devices also feature several control lines for the purposes of generating handshake signals with peripherals and generating microprocessor interrupts etc.

The second interface method is to connect the peripheral device directly to the microprocessor Data Bus. This method is termed Memory Mapped I/O which as its name implies, is to make each peripheral I/O function appear to the microprocessor as a normal memory location. This allows the full set of memory reference instructions to be used for I/O data transfer, but also implies that the peripheral device must be capable of responding at least as fast as memory, and hence it should be compatible with the MPU bus timing characteristics. With 10-bit converters a problem exists when using this method in that the 8-bit data bus is not wide enough to handle the converter data as a single word. It is therefore necessary to split the data into two words usually of 8 and 2 bits which are fed to the data bus in two separate bytes by means of appropriate gating on the converter outputs. Naturally when using a 16-bit microprocessor this problem does not arise, as converter data can then be read as a single word on the data bus. The disadvantages of Memory Mapped I/O are that it usually requires additional address decoding logic and also, since the I/O will be addressed as memory, there will consequently be fewer addresses available for actual memory. A variation of Memory Mapped I/O commonly referred to as I/O Mapped I/O or Isolated I/O is available on some microprocessors which overcomes this last disadvantage. This allows a defined range of memory addresses to be used also for I/O by means of separate Input and Output instructions. A special control output is used to tell the memory I/O devices whether the address of the current Read to Write cycle refers to memory or to I/O. This technique, does, however, restrict the freedom of the programmer to the use of these Input/Output instructions which usually operate only on data in the microprocessor accumulator.

So far we have dealt with interfacing to the ZN432 using the parallel binary outputs, alternatively the Serial Output can be used in applications which demand that the number of lines to the converter need to be kept to a minimum. Two schemes are briefly described here although other variations are possible. The first would be to connect the Serial Output to one I/O pin of an I/O device and to use the Status Output to generate microprocessor interrupts via one of the I/O device control inputs, thereby reading the serial data from the I/O device on the positive going edge of each pulse on the Status Output. The other method is to use a microprocessor with a direct Serial input part such as the 8085A. This would either involve synchronising the converter clock to a sub-multiple of the microprocessor clock and programming the microprocessor to read the data at the correct time, or by again using the Status Output to generate an interrupt. Unfortunately both these methods restrict the maximum converter clock period to a minimum of at least several instruction execution times i.e. the time needed to interrupt the microprocessor, read the data and store it in memory. Another option open to the designer would be to use a cascadeable shift register with 3-state outputs (i.e. a TTL 74LS395A) at the microprocessor and to convert from 10-bit serial to parallel data which would then be applied direct to the data bus in 2 words via the three-state outputs.

A ZN432 I/O INTERFACE

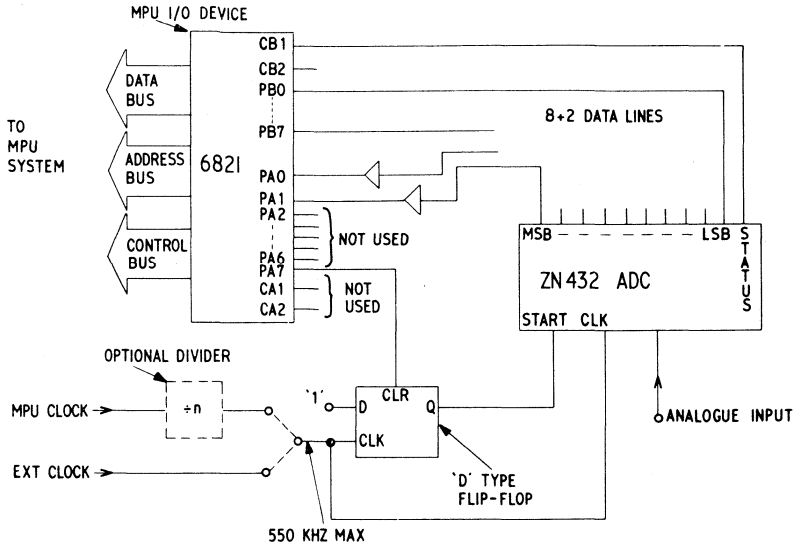

Fig. 4. ZN432 – 6800 I/O INTERFACE

Figure 4 illustrates one configuration of interfacing the ZN432 to an I/O device; in this case the 6821 Peripheral Interface Adaptor (PIA) device of the 6800 microprocessor family.

The PIA provides a flexible means of interfacing byte orientated peripherals to the microprocessor through two 8-bit bi-directional peripheral data lines and four control lines. The functional configuration of the PIA is under the full control of the microprocessor. Each of the peripheral data lines can be programmed individually to act either as an Input or an Output and each of the four control lines may be programmed for one of several control modes.

The diagram shows all 8 lines from Port B and 2 lines from Port A connected to the binary outputs of the ZN432. These lines are programmed as Inputs and allow the microprocessor to read the converted data by the execution of a microprocessor read peripheral data operation. Note the use of the two buffers on data lines PA1 and PA2, these are necessary due to the higher input current of the Port A inputs.

The converter clock can be supplied either from the microprocessor clock or from an external source. Use of the microprocessor clock is preferable since this allows a precise calculation to be made of the conversion time in terms of microprocessor machine cycles. If, however, the microprocessor clock is greater than the maximum converter clock rate of 550 kHz then it must be divided down to an acceptable level.

The 'D' type flip-flop is used to generate the Start pulse for the converter from the PA7 line, programmed as an output. The function of this flip-flop is to ensure that the Start pulse timing criteria with respect to the clock are met as explained earlier.

The STATUS output from the ZN432 is connected to the CB1 control line. This can be programmed to set the interrupt flag bit-7 in Control Register B of the PIA, on occurrence of a positive transition of the CB1 input signal. The contents of this register can be read by the microprocessor and the state of this bit tested to determine the completion of the conversion cycle. Alternatively the PIA can be

The configuration illustrated in figure 5 shows a suggested scheme for interfacing several ZN432's to an I/O device. This arrangement is similar to that previously described but in this circuit three-state buffers are used to interface each ZN432 to a common 10 bit bus from the PIA. The previously redundant lines PA2 – PA6 are now used to provide the enable signals for the three-state buffers. Note that the buffers of only one converter should be enabled at any one time otherwise false data will be read from the PIA.

The STATUS output of the ZN432 has a resistive pull-up load allowing typically up to 4 outputs to be 'wire-anded' together to form a common interrupt line. With the particular configuration shown a common Start signal for all the converters is produced, again from PA7 via the 'D' type flip-flop. Application of this signal would start all the converters simultaneously and a positive transition on the CB1 line would signify that all the converters had finished. Data from each converter would then be read by enabling the 3-state buffers via lines PA2 – PA6 in turn.

A ZN432 BUS INTERFACE

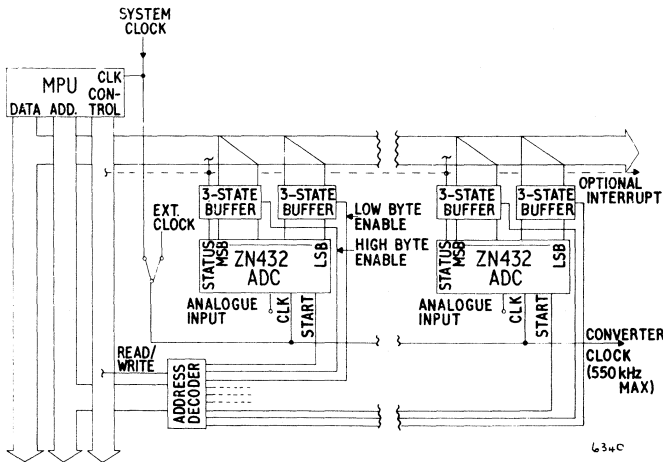

Fig. 6. MULTIPLE ZN432 MICROPROCESSOR BUS INTERFACE

The most versatile way of interfacing to a microprocessor is to go directly onto the Data Bus. Figure 6 illustrates this concept with the ZN432 where three-state buffers are again used but this time connected directly to the Data Bus of an 8-bit microprocessor such as the 6800. Since it is only an 8 bit bus the converter data has to be read in two words by enabling the buffers per converter in two groups as indicated by the High and Low Byte Enable lines per converter. One suggested scheme would be to transfer the output data as shown in Table 1. (Note that in converter terminology Bit 10 is the least significant bit (LSB)).

TABLE 1

Data Bus Lines	Low Byte	High Byte
D7	Bit 3	—
D6	Bit 4	—
D5	Bit 5	—
D4	Bit 6	—
D3	Bit 7	—
D2	Bit 8	(Status)
D1	Bit 9	Bit 1 (MSB)
D0	Bit 10 (LSB)	Bit 2

The STATUS output can be read on the Data Bus with the High Data Byte or alternatively these outputs can be 'wire-anded' or gated together to produce a common interrupt signal.

The Start pulse and High and Low Byte Enable signals are generated from a logic block labeled 'Address Decode Logic'. The function of this is to drive the appropriate input when the address, which has been allocated to that particular input, is present on the Address Bus and the Control Bus signals indicate a valid Memory Read or Write operation. Note that the level of address decoding used must ensure that the three-state buffers are disabled at all times except when the actual converter data should be on the bus, otherwise bus contention problems, with other devices using the bus may occur. A convenient means of address utilisation for the system in figure 6 is shown in Table 2, which allocates two consecutive addresses to each converter.

TABLE 2

ADDRESS	MPU READ	MPU WRITE
XXX 0	High Byte Enable ADC1	Start ADC1
XXX 2	Low Byte Enable ADC1	Start ADC1
XXX 2	High Byte Enable ADC2	Start ADC2
XXX 3	Low Byte Enable ADC2	Start ADC2
XXX 4	High Byte Enable ADC3	Start ADC3
etc.	etc.	etc.

(XXX = unique address for particular MPU system.)

A Write instruction to either address will then start that converter. On completion of the conversion, detected either by interrupt, testing of the Status Bit, or fixed program delay, the converter data can be read by a double byte load instruction which will load the data into two consecutive RAM memory locations or into a 16 bit microprocessor register, (i.e. Instruction LDX – Load Index Register of the 6800, loads the more significant byte of the index register from the byte of memory at the address specified by the program and loads the less significant byte of the index register from the next byte of memory at one plus the address specified by the program).

Note that the 'D' type flip-flop is not shown in figure 6. With a direct microprocessor clock it is possible to design the address decode logic so that the timing criteria of the Start pulse with respect to the clock input is complied with.

SUMMARY

Numerous different microprocessors are currently available and each microprocessor based control system will have its own individual data acquisition requirements. It is impossible in a paper of this type to cover all possible permutations of microprocessor/converter interfaces, but adoption of one of the two basic methods described here should be possible with most 8-bit microprocessors, allowing the design engineer to produce the most efficient data acquisition system to meet his design objectives. The ZN432's versatility and ease of use, coupled with its wide operating temperature range and TTL compatibility, will allow it to be used in a diverse range of applications where 10-bit accuracy is necessary.

Further information on the device characteristics and gain selection components, etc., is given in the ZN432 Series Data Sheet.

A Serial Interface For The ZN427 A/D Converter

A SERIAL INTERFACE FOR THE ZN427 A/D CONVERTER

In many data acquisition applications it is advantageous to situate the A/D converter close to the transducer and to transmit the digital data in serial form back to the data collection centre of the system. The serial data link uses less conductors and provides better noise immunity than a parallel data bus. This application note describes a RS-232C compatible serial data interface for the ZN427 8-bit A to D converter using an industry standard 6402 UART.

A simplified block diagram is shown in Fig. 1.

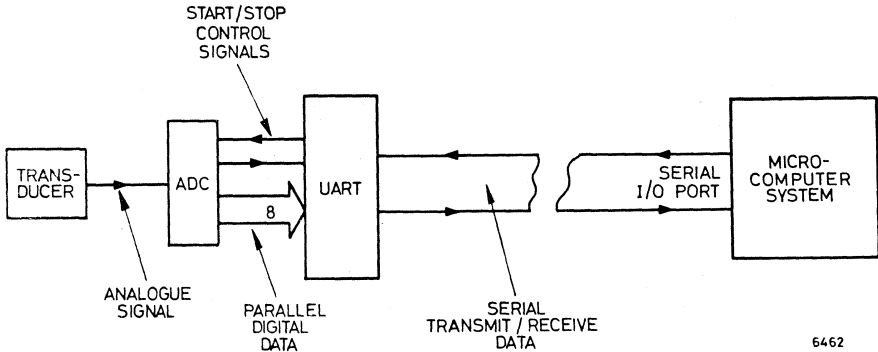

Fig. 1 Serial Data Interface

In order to initiate a conversion cycle a character is transmitted by the microcomputer. Upon receipt of this character by the UART its DR (Data Received) output goes to a high level which generates a start pulse for the A/D converter triggering a conversion cycle. At the end of the cycle the EOC (End of Convert) output is used to load the converted data into the UART which performs a parallel to serial conversion and transmits the data back to the microcomputer.

The ZN427 is an 8-bit successive approximation A to D converter. It features 3-state output buffers to permit bussing onto common data lines, fast 10 μ s conversion time and no missing codes over the full operating temperature range. The ZN427 contains a voltage switching D to A converter, a fast comparator, successive approximation logic, three-state output buffers and a 2.5V precision band-gap reference. A logic diagram of the converter is shown in Fig. 2. Only a few passive external components are required. For basic operation these are an input resistor, a reference current resistor and stabilising capacitor, and a limiting resistor for the negative supply current. This will provide a nominal input voltage range of 0 to $V_{REF IN}$. Other input ranges both Unipolar and Bipolar can be obtained by connecting a simple resistor network to V_{IN} (Pin 6) as illustrated in Figs. 3(a) and (b). Further information on the ZN427 can be found in the Data Sheet.

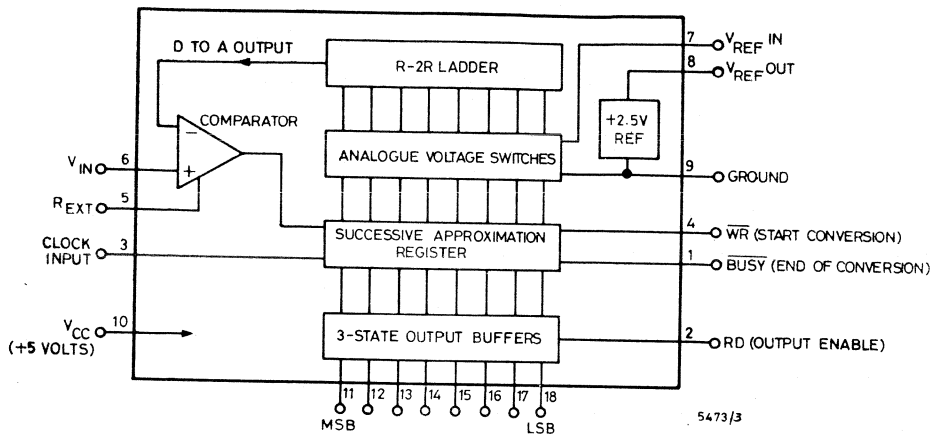

Fig. 2 System Diagram

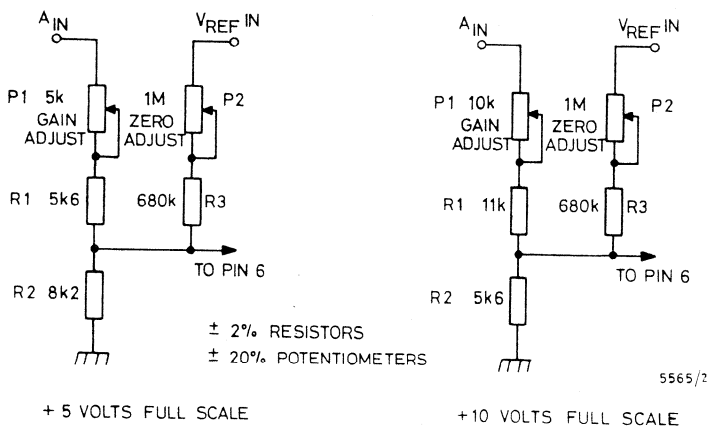

Fig. 3a Unipolar Operation - Component Values

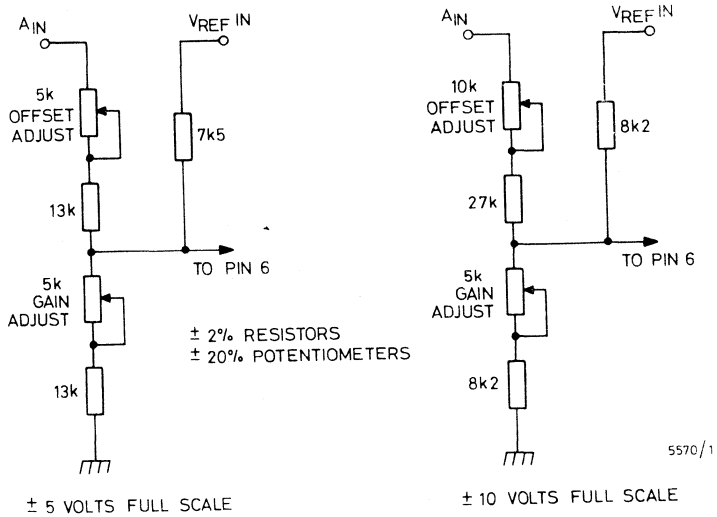

Fig. 3b Bipolar Operation – Component Values

A detailed circuit diagram of the converter interface is shown in Fig. 4.

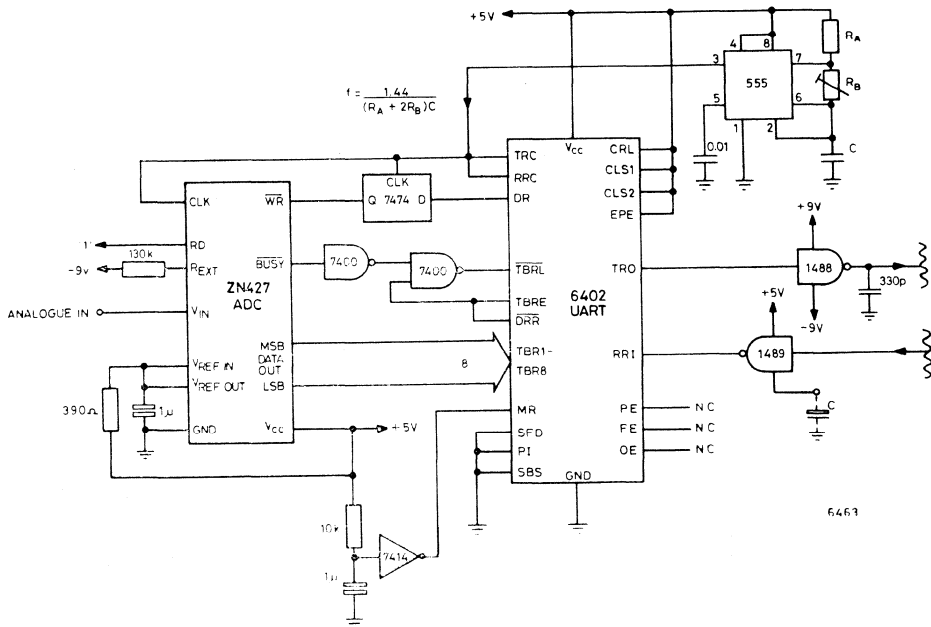

Fig 4. ZN427 UART Interface

The DR output of the UART is connected to the 'D' input of the 7474 latch, the 'Q' output of which drives the \overline{WR} (Start Convert) input of the ADC. The use of this ensures that the timing of the \overline{WR} pulse with respect to the converter clock input is correct. On the ninth negative clock edge after the \overline{WR} pulse the \overline{BUSY} output goes to a high level signalling that the conversion cycle is complete. This low to high transition is used to load the data into the UART via the TBRL (Transmitter Buffer Register Load Input). The signal is gated with the TBRE (Transmitter Buffer Register Empty) signal which holds the TBRL input high until the UART transfers the data to its transmitter register. If TBRL were allowed to return low before TBRE went high the converter data would be overwritten since the TBR (Transmitter Buffer Register) is a transparent latch. The TBRE signal is also used to drive the DRR (Data Received Reset) input which clears the DR output to a low level allowing another character to be received.

The waveforms associated with this operation are shown in Fig. 5. A simple oscillator using a 555 I.C. is shown which generates both the ADC clock and the Transmit/Receive clocks for the UART. The external clock is 16 times the data rate, the signal being divided internally by the UART. If a more stable data rate is an important factor then the 6403 UART, which is functionally similar but which uses a crystal oscillator as the timing source, may be substituted. In this case the ADC clock would still be generated by the 555 since it is not necessary for the converter and UART clocks to be synchronous. The UART control inputs CLS1, CLS2 (Character Length Select) ; PI (Parity Inhibit) ; EPE (Even Parity Enable) ; SBS (Stop Bit Select) are hard wired for whatever data format is wanted.

The MR (Master Reset) input is driven via a 7414 Schmitt trigger I.C. from a R-C delay circuit to generate the recommended reset pulse after power-up.

The 1488 and 1489 I.C.'s shown buffering the UART TRO (Transmitter Register Output) and RRI (Receive Register Input) pins are RS-232C compatible line drivers and receivers.

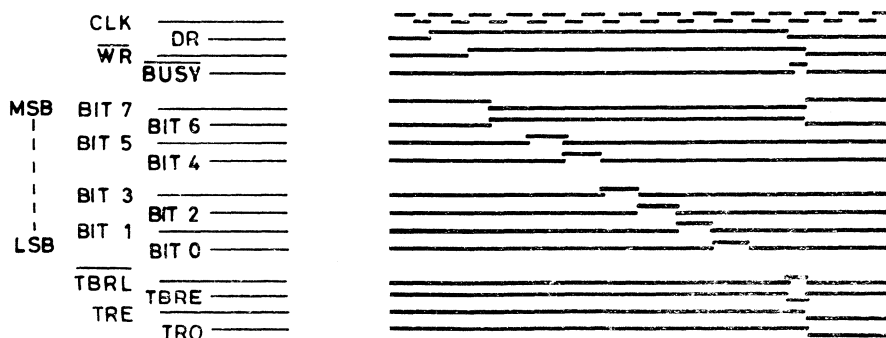

6464

Fig. 5 ZN427 UART Interface Waveforms

In some applications incorporating microcomputers with RS-232C serial I/O ports no additional interfacing at the data collection centre end will be necessary. However if only a parallel I/O port is provided then another UART to convert the serial data back to parallel will be needed. An interface for the PET microcomputer which connects to the Parallel User Port on connector J2 is shown in Fig. 6. This uses the eight I/O data lines. PA0-PA7 and two control lines CA1 and CB2 which originate from a 6522 Versatile Interface Adaptor I.C. The data lines PA0-PA7 are connected to the RBR (Receive Buffer Register) outputs of the UART. The CA1 input is driven by the UART DR output and is operated in the latched mode which stores the received data within the VIA on a positive transition of this pin. In order to initiate a new reading from the ADC the remaining control pin CB2 is used. This is connected to the UART inputs DRR and TBRL. When programmed to produce a negative going pulse the DR output is reset and a character is transmitted to the converter UART to start a new conversion cycle.

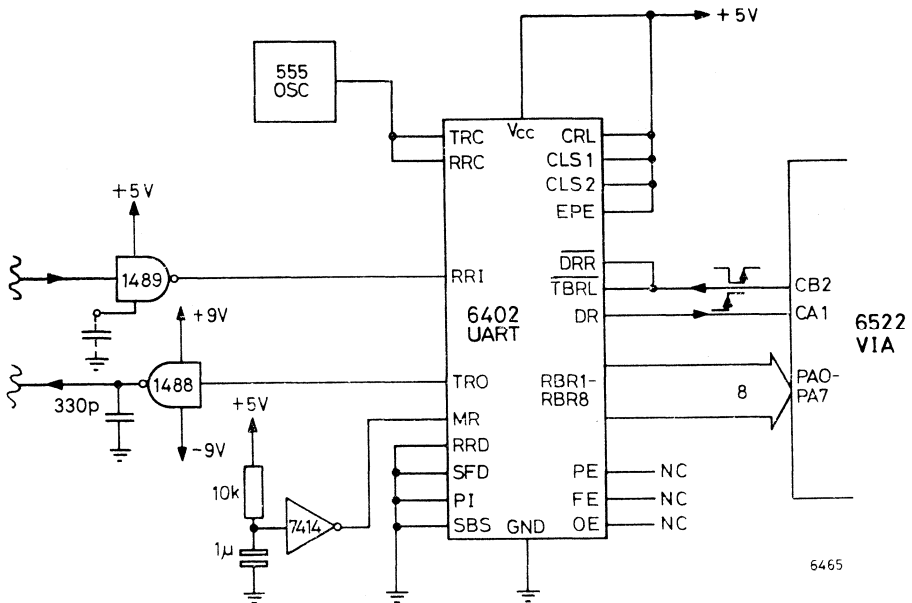

Fig. 6 6522 VIA UART Interface

A simple program example written in PET Basic is shown below.

PROGRAM EXAMPLE

```
10 REM UART INTERFACE REV. 3
20 REM SET PORT A TO INPUTS
30 POKE 59459, 0
40 REM DISABLE CA1 INTERRUPT
50 POKE 59470, 2
60 REM SET PCR TO 111XXXX1
70 POKE 59468, PEEK (59468) OR 225
80 REM SET ACR TO XXX000X1
90 POKE 59467, PEEK (59467) AND 227 OR 1
100 REM CLEAR CA1 FLAG IN IFR
110 A = PEEK (59457)
120 REM PULSE CB2 LOW-HIGH
130 POKE 59468, PEEK (59468) AND 31 OR 192
140 POKE 59468, PEEK (59468) OR 225
150 REM WAIT FOR +TRAN ON CA1
160 REM TEST CA1 FLAG IN IFR
170 IF (PEEK (59469) AND 2) THEN 190
180 GOTO 170
190 REM READ IRA AND CLEAR CA1 FLAG
200 A = PEEK (59457)
210 PRINT A
220 GOTO 120
```

Initially the appropriate VIA internal registers are set up and then a negative going pulse is produced on the CB2 pin. This starts a conversion sequence and when the new data is received the CA1 input goes high, latching the data in the VIA, and setting the CA1 Flag bit in the Interrupt Flag Register. This flag is tested by the program and when set the data is read and printed out. CB2 is again pulsed low and the sequence repeated.

For 6502 based microcomputer systems where all I/O lines of a 6522 VIA are available the CA2 pin can be used in the Read Handshake Mode in place of the CB2 pin, simplifying the program. Also the Status Flag of the UART can be monitored by the other I/O port lines for error checking purposes.

A Single Channel Codec

Acknowledgement: Ferranti wish to thank Mr. J. Everard and his colleagues of the British Post Office whose work this report is based upon and the Institute of Electrical and Electronic Engineers Inc. for permission to use extracts from a paper titled 'A Single Channel Codec' written by J. Everard and presented at ISSCC 78-Toronto.

INTRODUCTION

Conventional techniques for pulse code modulation (pcm) conversion for use in completely digital switching systems employ ladder networks requiring many high precision components to define the quantiser characteristic to sufficient accuracy. Alternative techniques employ linear ramps requiring either excessively high clock speeds or a number of ramps of precisely relative slopes.

In order to meet the signal-to-noise and gain-linearity constraints usually imposed on such systems, particularly for the telecommunications market, the use of expensive analogue to digital and digital to analogue hybrid circuitry is necessary. Due to the very high cost of the A/D and D/A component, multi-channel multiplexing techniques are usually employed.

The system described herein uses an advanced approach to a pcm codec (coder/decoder) designed at the British Post Office Research Centre at Martlesham Heath. The original aim was to produce an inexpensive codec capable of fully meeting the relevant C.C.I.T.T. recommendations. The B.P.O. realised that the way to achieve this was to make optimum use of state-of-the-art semiconductor L.S.I. technology. One such technology chosen was the Ferranti L.S.I. bipolar process. The result is a single channel codec of the type outlined in figure 1. The L.S.I. codec chip is the Ferranti ZNPCM1, the performance of which completely meets the performance specification defined by the British Post Office. The operation and realisation of the single channel codec is described in the following pages.

SYSTEM CONSIDERATIONS

The B.P.O. adopted an approach based on the principle of conversion to and from pcm via an intermediate digital code format, i.e. the encoder may consist of a waveform tracking encoder to provide highly oversampled A/D conversion followed by digital processing logic to convert the intermediate code to pcm. The decoder may consist of digital processing logic to convert pcm to some intermediate code format and a simple D/A to convert from the intermediate code to analogue. B.P.O. studies revealed that a trade-off was necessary between analogue A/D and D/A simplicity and conversion logic speed and complexity.

The trade-off was taken to its limit resulting in the simplest form of A/D and D/A converters possible providing that circuitry was realisable with state-of-the-art L.S.I. technology. Fig. 1 shows a block schematic of the basic codec.

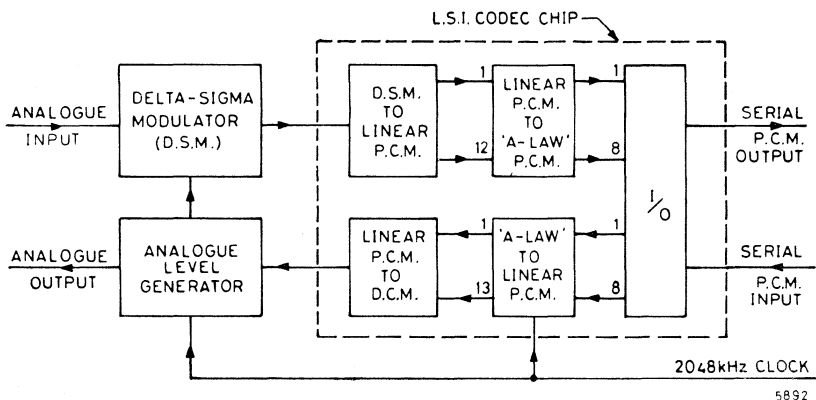

Fig. 1. Codec Schematic

The intermediate code format chosen for both encoder and decoder is that produced by a delta sigma modulator (dsm). It is especially simple to convert from this format back to analogue as one only has to pass the digital stream through a low pass filter cutting off just above the highest signal frequency to be recovered (3.4 kHz).

The area enclosed by the dotted line indicates the functions integrated into the L.S.I. codec chip ZNPCM1. The dsm circuitry is presently realised using discrete TTL logic, a differential amplifier, resistors and capacitors. However under development at present at Ferranti is an I.C. dsm solution which will be available by mid-1979.

THE DELTA SIGMA MODULATOR (DSM)

A modified form of delta sigma modulator/demodulator is used, resulting in an adequate performance using a clock rate as low as 2.048 kHz. Fig. 2 shows the functional circuit of the dsm, incorporating an operational amplifier integrator, and a D-type bistable for the threshold detector and approximation level generator. The modulator accepts a band-limited analogue input signal (300-3400 Hz) and converts it to one bit/sample delta sigma code format at a high sampling rate. The demodulator produces one of two precisely defined analogue levels in response to the single bit/sample delta sigma bit stream.

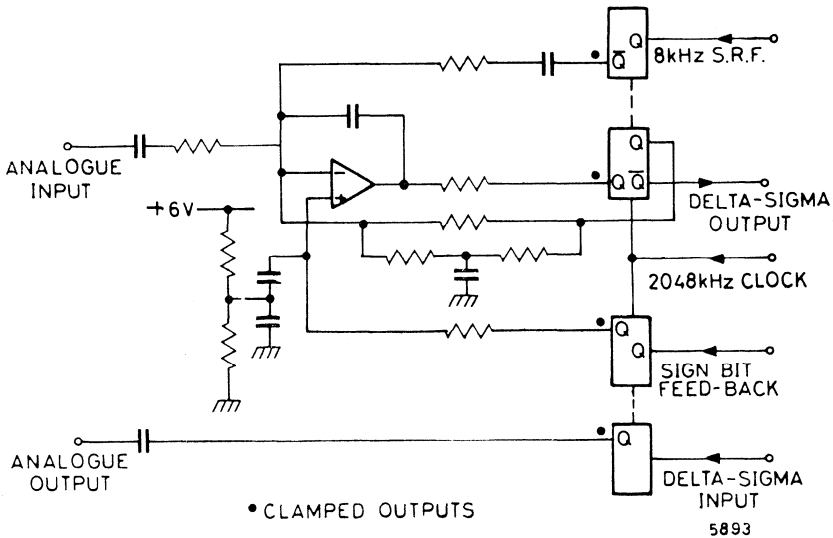

Fig. 2. Modulator/Demodulator Circuit

The modulator circuit relies on the use of two logic signals being fed back from the code converter; the sign bit of the generated pcm codewords, used to control the d.c. alignment conditions, and an 8 kHz square wave (Spectral Redistribution Function) which is added to the input signal to improve performance. A complex feedback network is also used to feed back a higher level of quantisation noise below approximately 16 kHz to shift quantisation noise to higher frequencies where the code converter provides greater suppression. In the reverse direction the decoder delta sigma stream coming from the code converter is passed through a D-type bistable for edge re-timing and level definition before the required analogue signal is recovered by low-pass filtering.

Encoder and decoder gain errors due to initial component variations from their nominal values are corrected at a gain adjustment point in the system. The main requirement is on gain stability, rather than absolute gain. The gain is a factor of both resistor ratios and the D-type output voltages. The output voltages are stabilised by supplying the quad D-type from a 5 volt regulator, which is always associated with the codec, and clamping the high state output voltages to a 2.45V reference by the use of schottky diodes. These also help to match the voltages influencing the d.c. alignment conditions and minimise the effects of power supply variations and noise. Resistor ratio stability is obtained, together with a small modulator/demodulator physical size, by implementing the resistors and small capacitors as an in-line passive hybrid.

The modulator also includes a 'fast start' circuit to ensure rapid stabilisation of the d.c. conditions when the codec is powered-up. This is important when the codec is used in switching applications where considerable power savings arise if the codec is only powered-up when required.

The detail circuit of the dsm is shown in Fig. 3. In addition to the basic modulator and demodulator circuit the decoded output is shown being fed into a simple second order Sallen and Key filter. This is shown as a technique for demonstrating the equalisation of $\sin.x/x$ distortion resulting from the sample and hold process of the decode function. The compensation would normally be provided as an integral part of the decoder band limiting filter.

Ferranti have under development an integrated circuit version of the dsm and samples will be available by mid-1979. The I.C. version will be much less dependent on external component tolerances than the discrete version. Only 7 or 8 external R and Cs will be required. The I.C. will be available in an 18 pin plastic or ceramic package and should also allow improved speed performance compared to the discrete solution. Fig. 4 shows an advance drawing of what the two I.C. single channel codec is expected to be, however this may be subject to change depending upon the final evaluation of the dsm integrated circuit.

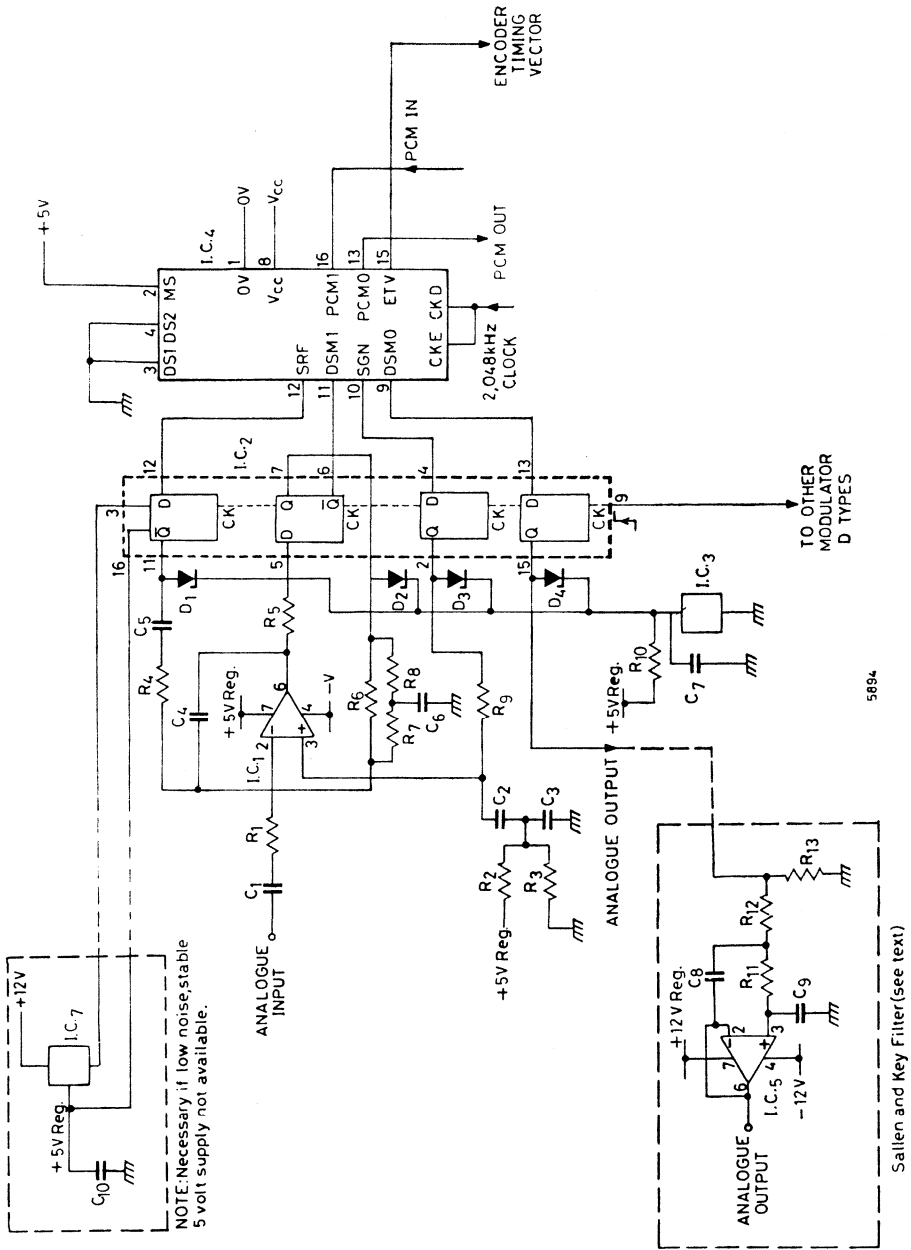

Fig. 3. Discrete Delta Sigma Modulation Circuit

COMPONENTS LISTING FOR COMPLETE CODEC CIRCUIT

1. MAIN CIRCUIT

Integrated Circuits

I.C.1	—	CA3140S/T
I.C.2	—	SN74175N J or ZN74175 E/J
I.C.3	—	ZN458
I.C.4	—	ZNPCM1E or J

Diodes

D1, D2, D3 and D4	—	ZC2800 or 1N6263
-------------------	---	------------------

Capacitors

C1	—	3.3 μ F \pm 20%
C2 & C3	—	6.8 μ F \pm 20% (6.3V)
C4	—	68 pF \pm 20%
C5	—	15 nF \pm 10%
C6	—	10 nF \pm 2%
C7	—	6.8 μ F \pm 20% (6.3V)

} +15%, -18% (See Note 1)

Resistors

R1	—	2.7k Ω \pm 2% (High Stability Resistor)
R2	—	10k Ω \pm 2%
R3	—	4.7k Ω \pm 2%
R4	—	47k Ω \pm 2%
R5	—	620 Ω \pm 5%
R6	—	10k Ω \pm 2% (High Stability Resistor)
R7 and R8	—	2k Ω \pm 2% (High Stability Resistor)
R9	—	2.7k Ω \pm 10%
R10	—	260 Ω \pm 10%

NOTE 1. Limits apply over temperature range and equipment working life.

NOTE 2. High stability resistors should track each other to \pm 1% to meet British Post Office Specification Requirements.

2. SUBSIDIARY CIRCUITS

Integrated Circuits

I.C.5	—	ZLD741C
I.C.7	—	LM78L05ACH

Capacitors

C8	—	1 nF \pm 2%
C9	—	10 nF \pm 2%
C10	—	2.2 μ F \pm 20%

Resistors

R11 & R12	—	91.8k Ω \pm 1%
R13	—	100k Ω \pm 5%

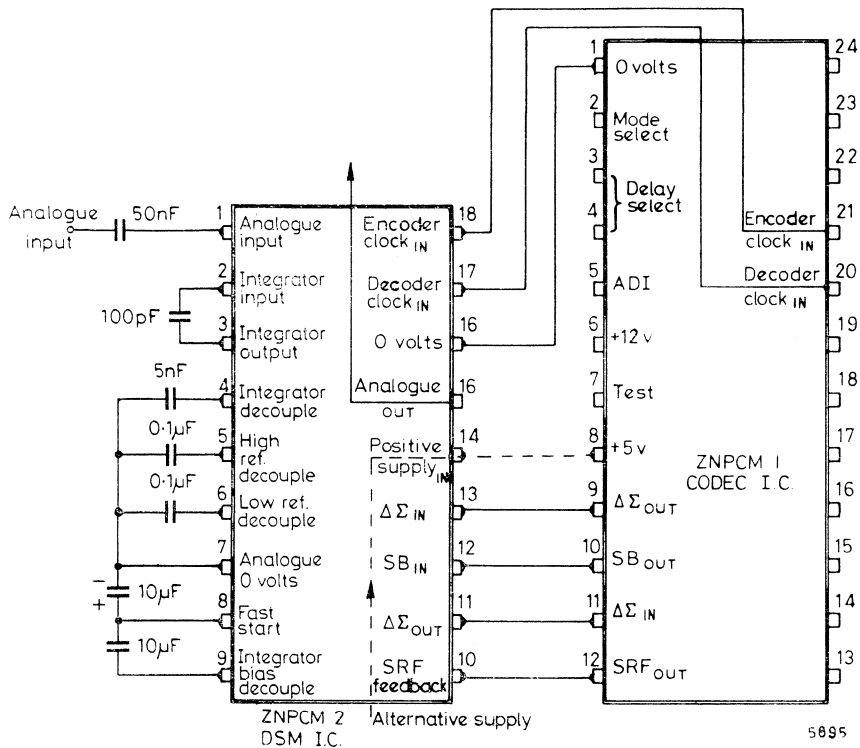

Fig. 4. DSM-Codec Interface

THE CODE CONVERSION

The dsm signal is fed into the integrated circuit at 2,048 kbits/second and converted to compressed pcm at a bit rate of 64 kbits/s or, by the application of external timing signals a maximum of 2,048 kbits/s for multiplexing in a burst format. Conversely the I.C. will accept at the pcm interface either a 64 kbit/s stream or, by the application of external timing signals, a bit rate of up to 2,048 kbit/s in a burst format. This is then converted to a delta sigma pulse stream of 2,048 kbit/s. The actual code conversion can be broken down into two stages; (i) Delta Sigma to linear pcm and vice-versa; (ii) Linear pcm to compressed pcm and vice-versa.

(i) Delta sigma to Linear pcm

The converter operates by multiplying the 256 delta sigma input samples occurring in each 125 microsecond pcm sample period by coefficients according to a triangular profile and accumulating the products to form the required linear pcm codeword at the end of the interval. Fig. 5 shows the converter logic structure.

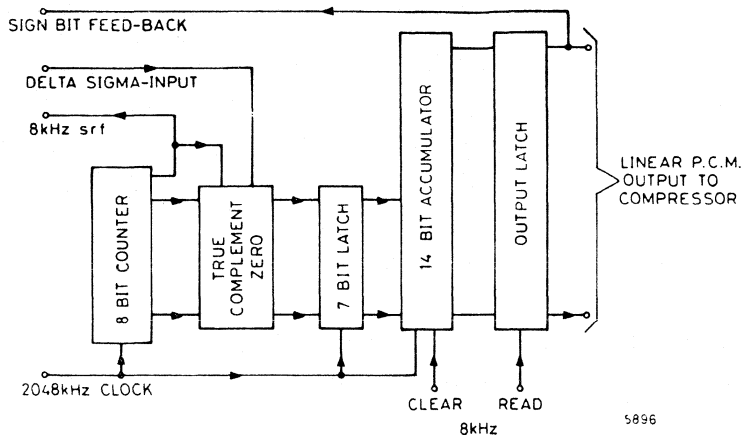

Fig. 5. Delta sigma to Linear pcm Converter

It consists of an eight bit counter, logic for operating on the seven least significant bits of the counter, a re-timing buffer, a 14 bit accumulator and an output latch. The first seven bits of the counter generate numbers zero to 127 as shown in Fig. 6(a). The eighth bit divides the generated number sawtooth into odd and even phases as shown in Fig. 6(b). Bit eight is also used in conjunction with the delta sigma ($\Delta\Sigma_i$) output to operate on the seven bit count sequence to produce the correct value of $\Delta\Sigma_i W_i$ to be added into the accumulator, where W_i is the required weight from the triangular profile during the i th clock period.

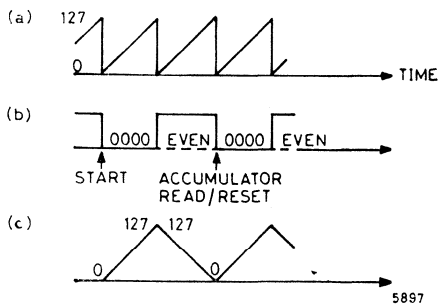

Fig. 6. a) 7 Bit Counter Number Sawtooth
 b) Counter Most Significant Bit
 c) Effective Available Weight Sequence

The technique of generating a triangular co-efficient profile allows a continuous up-counter to be used, which in turn allows the easy generation of the required timing waveforms to drive different parts of the codec. The 8 kHz square wave used within the modulator is taken from the most significant bit of the counter and the sign bit feedback to the modulator is derived from the output latch.

The converter produces 14 bit linear pcm codewords at 8k samples/s with an effective accuracy such that the signal to noise ratio obtained, after converting the 'A' law pcm, complies with C.C.I.T.T. recommendations.

In the decode direction the principle of conversion is the implementation of the delta sigma algorithm (see appendix 1) in all digital logic. The linear pcm input appears as a sample and held signal, the digital dsm performing a continuous conversion to the delta sigma format. The realisation of the circuitry is shown in Fig. 11.

(ii) *Linear PCM to Compressed PCM*

A useful relationship exists between linear pcm codewords and their 'A law' compressed equivalents allowing conversion between the two formats to be readily accomplished using data selection techniques. Fig. 7 shows a linear pcm to 'A law' pcm converter where the segment code is derived directly from the linear codeword using combinational logic. The segment code is then used to control a data selection matrix to extract the required interval code.

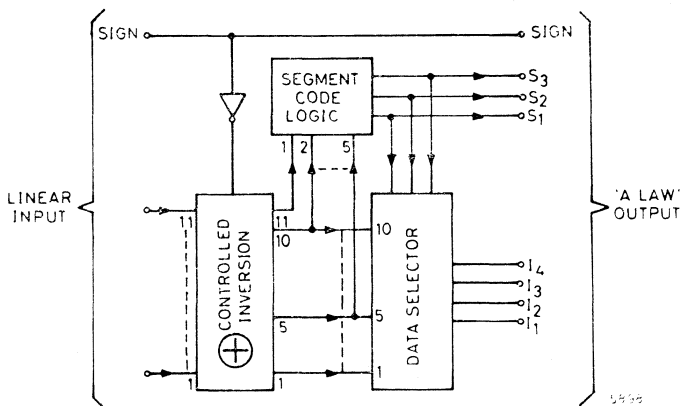

Fig. 7. Linear to 'A Law' Converter

Facilities are provided for controlled alternate digit inversion of the 'A law' codewords prior to parallel to serial conversion for serial output. In most applications ADI must be provided but for testing purposes it is useful if it can be removed.

Similar techniques are used in the decode direction to convert the compressed pcm into linear pcm.

INPUT-OUTPUT INTERFACE

One of the most important features of a pcm codec is the structure of its input-output interface as this directly influences the ease with which the codec can be used in a given application. A very flexible I/O interface has been included which can operate in either of two modes by means of pin selection.

In the first mode the pcm codewords are clocked in and out automatically at 64 kbits using clocks internally derived from the applied 2,048 kHz clock. The only timing waveform required is a timing vector to indicate when the first bit (the sign bit) of each codeword is required (which automatically defines the positions of the other bits at this rate). To take account of many applications where the received pcm codewords are not in the frame alignment with the transmitted codewords, two pins are provided for the user to strap appropriately to indicate the actual displacement. The four possibilities allow for zero to three digits delay of the received with respect to the transmitted codewords.

In the second mode, a much wider range of operation is possible. The pcm codewords may be clocked in and out at any rate in the range 64 to 2,048 kbits. Access is provided to the output and input shift registers to allow the multiplexing and demultiplexing of signalling bits if required. Also separate encoder and decoder 2,048 kHz clock inputs are provided to allow asynchronous working between the two directions of transmission, which is typical of pcm multiplex applications.

ZNPCM1 – THE L.S.I. CODEC

From its initial conception the codec has been designed with a view to producing the circuit in an L.S.I. semiconductor technology. Using advanced circuit design, photographic mask making and processing techniques developed originally for the F100L 16 bit bipolar micro-processor² Ferranti have produced a single chip codec incorporating all the circuit functions shown in the dotted rectangle in Fig. 1. The device operates from a single 5V supply with a maximum operating frequency of 6 MHz and all inputs and outputs are TTL compatible. For reduced power requirements the device will operate down to 3.5V maintaining TTL compatibility and as low as 3V with some degradation of input/output voltage levels.

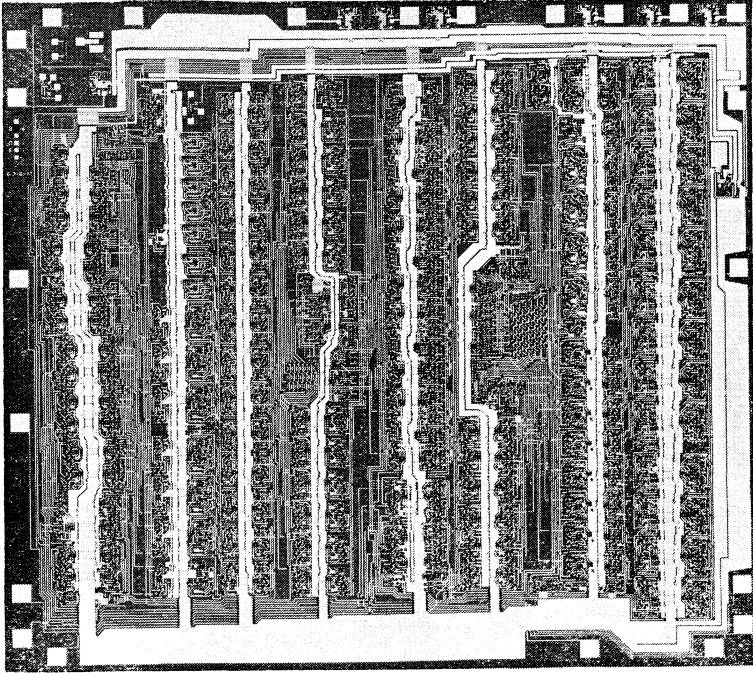

Fig. 8. Codec Chip Photograph

The chip size is 178 thou. by 163 thou. (see Fig. 8) and is available in a 24 lead D.I.L. ceramic (ZNPCM1J) or moulded package (ZNPCM1E).

Performance

The codec described meets all the performance requirements of the C.C.I.T.T. Recommendation G712 with good safety margins. Using a standard pcm multiplex tester and a spectrum analyser the following performance figures result :

1. Idle channel noise : -69 dBmOp
(C.C.I.T.T. recommendation = -65 dBmOp)
2. Signal-to-noise ratio and Gain-level linearity : Figs. 9(a) and 9(b) show the results using a 450-550 kHz pseudo-random noise test.
3. Intermodulation distortion :
Measured products are at least 10 dB and on average 18 dB better than the C.C.I.T.T. recommendations.

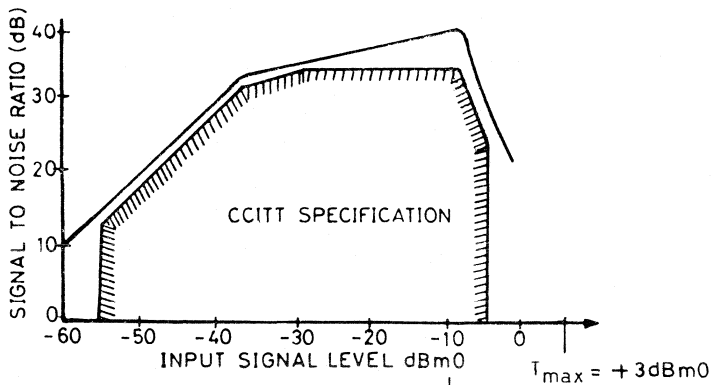

Fig. 9(a). Signal to Noise Ratio, 'A law'

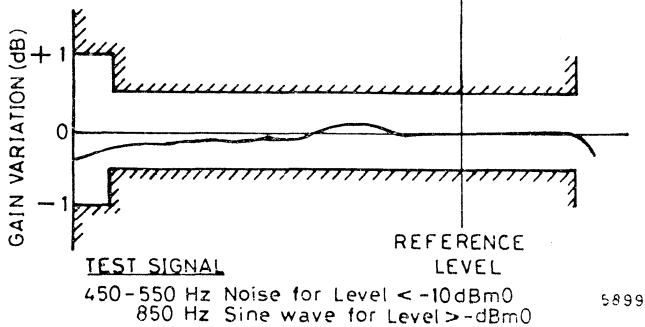

Fig. 9(b). Gain to Signal Level, 'A law'

Another aspect of the codec performance is the Sinc (πft) decoder frequency characteristic, having infinite attenuation at 8 kHz and multiples thereof, introduced by the digital full-width sample and hold process occurring within the code converter. Although this requires equalisation in-band with an appropriate analogue post filter design, the characteristic ensures complete suppression of the sampling frequency components and harmonics, independent of any d.c. offset in the received codewords.

The sinc (πft) characteristic is also useful when considering the design of less complex analogue filters to be used with the codec in digital switching applications, where codecs may be provided on a per customers line basis. A less complex filter may be allowable since, in the local telephone networks, there is not the problem of interworking with frequency division multiphase systems.

APPENDIX 1

DSM Hybrid

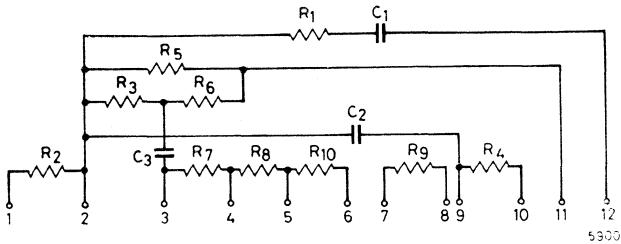

Component Values

R1	47kΩ		R4	620Ω		
R2	2.7kΩ		R9	2.7MΩ	}	
R3	2kΩ		R10	260Ω		
R5	10kΩ	±5%				
R6	2kΩ					
R7	4.3kΩ					
R8	10kΩ					
C1	15 nF	}			±20%	
C2	68 pF		+15%, -18%			
C3	10 nF					

Resistor Ratio Tolerances

$$\text{If, } R_p = \frac{(R_3 + R_6) R_5}{(R_3 + R_6 + R_5)}$$

then R_p/R_2 shall commence with $\pm 5\%$ of the nominal ratio and then remain with $\pm 1\%$ of the starting ratio over operating temperature range and equipment life.

The ratios R_p/R_1 and $R_7/R_7 + R_8$ will remain within $\pm 5\%$ of nominal ratios.

The tolerances quoted are those required over the temperature range and working life to obtain a performance compatible with that required by the British Post Office and may be relaxed for less stringent requirements.

The hybrid is packaged in a single in-line package with 0,24 mm lead pitch and a maximum length of 33 mm, width of 6,35 mm and height of 17,8 mm. For further details contact:—

Type: CN466A

Allen Bradley Electronics Ltd.,
Bede Trading Estate,
Jarrow,
Tyne and Wear, NE32 3HG
Telephone: 0632 (Jarrow) 897771.

Type: TIM529

Tectronic (Electronics Ltd.),
Cirtec Works,
Wokingham,
Berkshire, RCH 2YD
Telephone: 0346 (Crowthorne) 5115.

APPENDIX 2

Fig. 10 shows the algebraic notation used for the numbers existing within the modulator during the n th clock cycle.

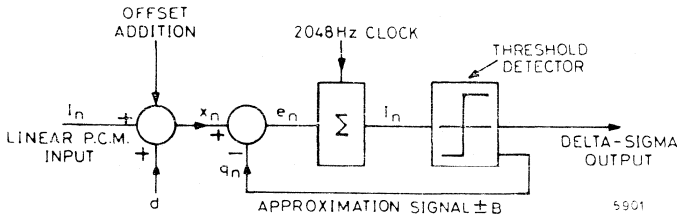

Fig. 10. The Digital DSM

The 13 bit linear pcm input I_n has a constant offset d added to it, resulting in a number $x_n = I_n + d$ being presented to the digital dsM. The offset d , equal to $1/16$ th of the peak pcm codeword magnitude, acts as a spectral redistribution function³ which improves the performances considerably. The approximation signal q used in the feedback loop can take one of two binary numbers $+B$ or $-B$. The difference $e_n = x_n - q_n$ is presented to a digital integrator. At the end of clock period ' n ', e_n is added to I_n , the integral or sum of all previous differences to form $I_n + 1$.

$$\text{i.e., } I_n + 1 = I_n + e_n = \sum_0^n (x_i - q_i)$$

The threshold detector outputs the sign of $I_n + 1$ which is used to control the sign of the approximation signal during the $(n + 1)$ th period the sign being chosen so as to minimise the integral,

$$\text{i.e., } q_n = +B \operatorname{sgn}(I_n + 1)$$

over a period of m dsM cycles

$$I_n = I_n - m + \sum_{n-m}^{m-1} (x_i - q_i)$$

Rearranging and dividing by m :

$$\frac{1}{m} \sum_{n-m}^{n-1} q_i = \frac{1}{m} \sum_{n-m}^{n-1} x_i - \frac{1}{m} (I_n - I_{(n-m)})$$

i.e., the mean value of q over m cycles is equal to the mean value of the input x plus some error term. The larger the value of m the smaller the error term becomes. Viewed in the frequency domain the feedback loop causes the low frequency components of q to track the baseband frequency components of the input x , any difference being the inband quantisation noise due to the transformation or coding process.

Fig. 11 shows the circuit realisation of the digital dsm. The simplicity of the configuration arises from choosing the magnitude of the approximation levels $\pm B$, such that the difference between x_n and q_n can be formed by combinational logic techniques on the most significant bits of x_n and q_n without performing a full subtraction operation. Generalising, if x is represented by a two's complement number k bits in length, then,

$$-2^{k-1} \leq x \leq 2^{k-1} - 1$$

The two possible values of q are made

$$+ B = 2^{k-1} \text{ and } - B = -2^{k-1}$$

As a consequence the $k + 1$ bit value of e can be formed by using the $k - 1$ least significant bits of x (unchanged) combined with two bits in the most significant positions which are inverses of the sign bits of x and q , hence the logic structure shown in Fig. 11. The digital dsm cycle rate is governed by the rate at which the accumulator latch is clocked, the delta sigma output being taken from the sign bit of the accumulator.

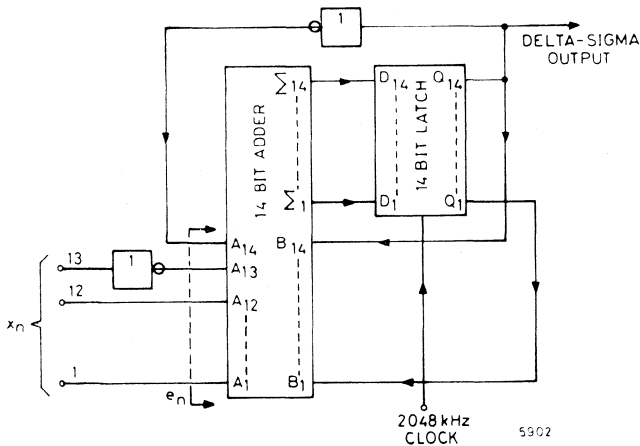

Fig. 11. Digital DSM Circuit Realisation

References

1. C.C.I.T.T. Orange Book Vol. III – 2 Rec. G711, 712.
2. F100L circuit, Design and Manufacture by Mr. D. Grundy – Electronic Equipment News, May 1978.
3. Everard, J.D. 'Single Channel PCM Codec' IEE Journal –Solid State CCTS Vol. COM 27 No. 2, Feb. 1979 par. 1 pp 25-38.

Ferranti Electronics Limited**Franchised Distributors:****UNITED STATES and CANADA****SALES OFFICE: NEW YORK Tel: (516) 543-0200****ALABAMA**

A. B. ANDREWS & CO. INC.
Tel: (205) 539-6817

ARIZONA

LION ELEC. INC.
Tel: (602) 869-9611

NORTHERN CALIFORNIA

PACESETTER ELEC.
Tel: (408) 734-5470

SOUTHERN CALIFORNIA

PACESETTER ELEC.
Tel: (714) 557-7131
Tel: (213) 299-7760

MYCO/VICKERS

MYCO/VICKERS
Tel: (213) 340-2025

CONNECTICUT

CRONIN ELEC. LTD.
Tel: (203) 265-3134

FLORIDA

R. C. SIMON & CO. INC.
Tel: (305) 941-2757

ILLINOIS

REPTON ELECTRONICS INC.
Tel: (312) 593-7070

MASSACHUSETTS

CRONIN ELEC. LTD.
Tel: (617) 449-5000

MICHIGAN

AMBUR ELECTRONICS INC.
Tel: (313) 669-3710

MINNESOTA

INDUSTRIAL COMPONENTS INC.
Tel: (612) 831-2666

NEW JERSEY

J. J. D. ASSOCIATES
Tel: (609) 983-2988

NEW YORK

TRACE ELECTRONICS INC.
Tel: (516) 249-4455

UPSTATE NEW YORK

ADD ELEC. INC.
Tel: (315) 437-0300

OHIO

APPLIED DATA MANAGEMENT
Tel: (513) 579-8108

PENNSYLVANIA

J. J. D. ASSOCIATES
Tel: (609) 983-2988

TEXAS

TEXCOMP
Tel: (713) 995-5356

CANADA

R-THETA INC.
Tel: (416) 475-8051

NORTHERN EUROPE**SALES OFFICE: ENGLAND Tel: 061-624 0515/6661****UNITED KINGDOM**

CELDIS LTD.
Tel: Reading (0734) 585171

FARNELL ELEC. COMPONENTS LTD.
Tel: Leeds (0532) 636311

INTEL ELEC. LTD.
Tel: Hitchin (0462) 821505

ITT ELECTRONIC SERVICES
Tel: Harlow (0279) 26777/26811

MIDWICH COMPUTER CO. LTD.
Tel: Diss (0379) 898751

SEMICOMPS LTD.
Tel: Keighley (0535) 65191
Tel: Kelso (05732) 24366
SWIFT-SASCO LTD.
Tel: Crawley (0293) 28700

BELGIUM

S. A. TELESON-ELECTRONIC N.V.
Tel: 021219
21.88.-219.21.94

DENMARK

A/S NORDISK ELEKTRONIK
Tel: (0 04 52) 84 20 00

FINLAND

OY ATOMICA A.B.
Tel: 0-423-533

FRANCE

CERAM
Tel: 577 42 50

HOLLAND

UNITED ELECTRIC EINDHOVEN B.V.
Tel: (040) 41 11 91

SWEDEN

FERNER ELECTRONICS A.B.
Tel: 8-80-25-40

WESTERN EUROPE**SALES OFFICE: W. GERMANY Tel: (089) 29 3871****AUSTRIA**

OTHMAR LACKNER
Tel: (00 43 222) 53 11 85/53 11 86

ITALY

DIMAC ELECTRONICS S.R.L.
Tel: (00 39 39) 49 14 45/49 15 14

SWITZERLAND

ELBATEX AG
Tel: (00 41 56) 27 01 27

WEST GERMANY

ALTRON A.E. THRONICKE KG
Tel: (0 51 32) 5 30 24

ASTRONIC GmbH
Tel: (089) 30 90 31

DR. GÜNTHER DOHRENBURG
Tel: (030) 213 80 43/45

ELBATEX GmbH
Tel: (0 71 31) 8 90 01

NORDELEKTRONIK GmbH

Tel: (0 41 06) 7 41 74

SEATRONICS GmbH

Tel: (06 11) 49 03 11

WEISBAUER ELEKTRONIK GmbH

Tel: (02 31) 57 95 47

REST OF THE WORLD**SALES OFFICE: ENGLAND Tel: 061-624 0515/6661****HONG KONG**

YES PRODUCTS LTD.
Tel: 0 4444241 6

JAPAN

CORNES & CO. LTD.
Tel: 272 5771



THE QUEEN'S AWARD FOR
TECHNOLOGICAL ACHIEVEMENT

 **FERRANTI**
semiconductors®
better by design

**Ferranti Electronics Limited, Fields New Road,
Chadderton, Oldham OL9 8NP, England.
Tel: 061 624 0515/6661 Telex: 668038**

**Ferranti GmbH, Widenmayerstrasse 5,
D-8000, Munich 22, West Germany.
Tel: 089 293871 Telex: 523980**

**Ferranti Electric Inc., 87 Modular Avenue,
Commack, New York 11725, USA
Tel: 516 543 0200 TWX: 510 226 1490 FERRANTI NY**