

# AMSTRAD

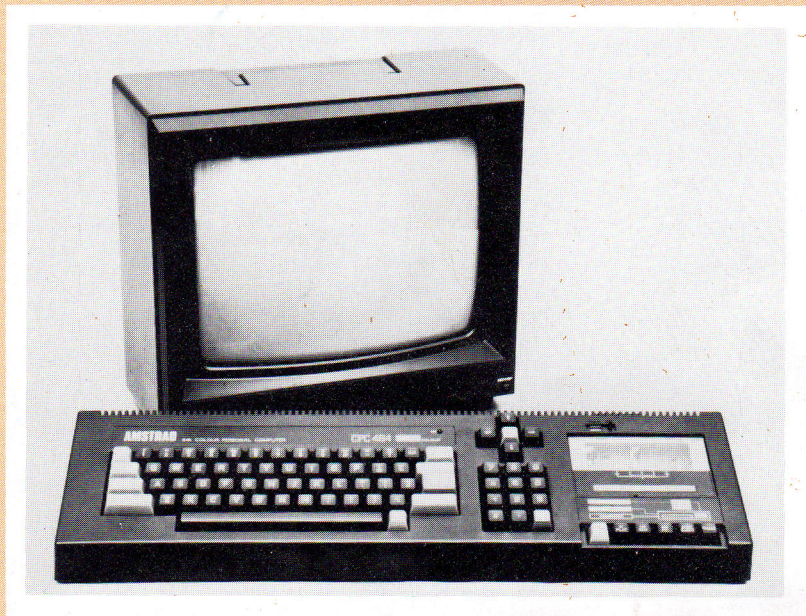

**CPC464  
MICRO COMPUTER  
CTM640  
COLOUR MONITOR  
GT64 GREEN MONITOR  
SERVICE MANUAL**

Price: £5.00

## CONTENTS

	Page
Technical Specification	2
Flash Test	2
CPC464 Cabinet Parts List	2
CPC464 Keyboard Cabinet Drawing	3
Cassette Mechanism and Parts List	4, 5, 6
Cassette Deck Alignment Instructions	6
CPC464 Cassette PCB	7
CPC464 Cassette Deck Circuit Diagram	8
CPC464 Basic Hardware Analysis	
Cassette & Software Analysis	10
CPC464 Function Diagrams	10 & 11
CPC464 Main PCB	12, 13 & 14
CPC464 Circuit Diagram	15 & 16
CPC464 Electrical Parts List	17
GT64 Cabinet Drawing and Parts List	18
GT64 Circuit Diagram & Voltages	19
GT64 Main PCB & Alignment Instructions	20
GT64 Electrical Parts List	21
CTM640 Cabinet Drawing & Parts List	22
CTM640 Electrical Parts List	23 & 24
CTM640 Alignment Instructions	23
CTM640 Voltages	24
CTM640 Circuit Diagram	back pull out
CTM640 PCB	back pull out

## TECHNICAL SPECIFICATION

### LSI CHIPS:

<b>Z80A</b>	processor running at 4MHz
<b>64K</b>	bytes of RAM (over 42K available to user)
<b>32K</b>	bytes of ROM containing BASIC and the operating system
<b>6845</b>	CRT controller device
<b>GI</b>	sound generator chip
	AY-3-8912 3 voice, 7 octave
<b>8255</b>	parallel I/O device interface to the GI sound chip

### DISPLAY SPECIFICATION:

	Normal	Mode High Res.	Multiclr.
No. of Colrs.	4 from 27	2 from 27	16 from 27
Vert. Dots.	200	200	200
Horiz. Dots.	320	640	160
Horiz. Chars.	40	80	20

### KEYBOARD:

74 keys — qwerty style, numeric cluster, cursor and copy cursor, large enter, shift, caps lock, tab, escape, delete, clear, control.

### DATAORDER:

Write speed software selectable — 1K baud or 2K baud, read speed automatically established by software. Write protect interlock. Motor on/off controlled by software.

### ADD-ON ABILITY:

Compact floppy disk drive system including CP/M\* and LOGO language.  
Centronics compatible printer.  
Joystick(s).  
Additional ROM's.  
Additional RAM up to 8160K.

### EXTERNAL SOCKETS:

PCB edge connectors for general purpose expansion and Centronics parallel printer.

9 Pin socket for joystick

6 Pin socket for — RGB and sync  
— composite video  
— luminance and sync

3.5mm socket for stereo sound output

5mm socket for CPC464 power supply (supplied exclusively from screen)

### DIMENSIONS (mm):

	w	h	d
Keyboard	: 580	70	170
CTM640	: 375	340	365
GT64	: 305	315	335

### WEIGHTS (kg):

Keyboard	: 2.4
CTM640	: 10.6
GT64	: 6.3

### POWER SUPPLY:

Screen System: 240V AC 50Hz  
(keyboard and datacorder power supplied by screen system)

\*CP/M is a registered trademark of Digital Research Inc. AMSTRAD and AMSOFT are trademarks of Amstrad Consumer Electronics PLC.

In keeping with our policy of continually improving our service, and technical quality of our products, we reserve the right to change component types, manufacturers, sources of supply or technical specification at any time.

Keyboard, Colour Monitor, Green VDU — Designed in U. K.  
Made in Korea

## CPC464 CABINET PARTS LIST

Sym	Description	Part No.
1	Top Cabinet 3 Ribs	170001
2	On/Off Switch	170002
3	Vol. Control Pot.	170003
4	Knob Vol. Control	170004
5	LED Red	170005
6	Cassette Lid	170006
7	Key Board Assy. Z7D101	170007A
7	Key Board Assy. Z70102	170007B
8	Rubber Contact mat. Key Board	170008
9	Rubber Contact Mat Digit	170009
10	Rubber Contact Mat Spacer	170010
11	Bottom Cabinet 3 Ribs	170011
12	Cassette Mechanism	170012
13	Tape Counter	170013
14	Counter Belt	170014
15	Record Button Cass.	170015
16	Play Button Cass.	170016
17	Rewind Button Cass.	170017
18	Fast Forward Button Cass.	170018
19	Stop/Eject Button Cass.	170019
20	Pause Button Cass.	170020
21	Cass. Door Spring	170021
22	I/O Socket	170022
23	User Port Socket	170023
24	D.C. Socket	170024
25	DIN Socket	170025
26	Inlay Main	170026
27	Inlay Cassette	170027
28	Keyboard Contact P.C.B. /A	170028
29	Keyboard Contact P.C.B. /B	170029
30	Bottom Cabinet 5 Ribs	170030
31	Top Cabinet 5 Ribs	170031
32	Speaker	170124

### SAFETY TEST

All monitors are safety tested to the following specifications.

#### 1). Flash Test

Test at 4kV between the live and neutral of the mains lead joined together and ALL accessible metal points on the exterior of the set.

#### 2). Insulation Resistance Test

Test between the live and neutral of the mains lead joined together and ALL accessible metal points on the exterior of the set to show a resistance of at least 4Mohm.

If after servicing there is any doubt about continued electrical safety the above tests should be carried out.

AMSTRAD CONSUMER ELECTRONICS PLC  
BRENTWOOD HOUSE, 169 KINGS ROAD,  
BRENTWOOD, ESSEX CM14 4EF  
Telephone: Brentwood (0277) 228888  
Telex: 995417 AMSELE G

CPC464 CABINET DRAWING

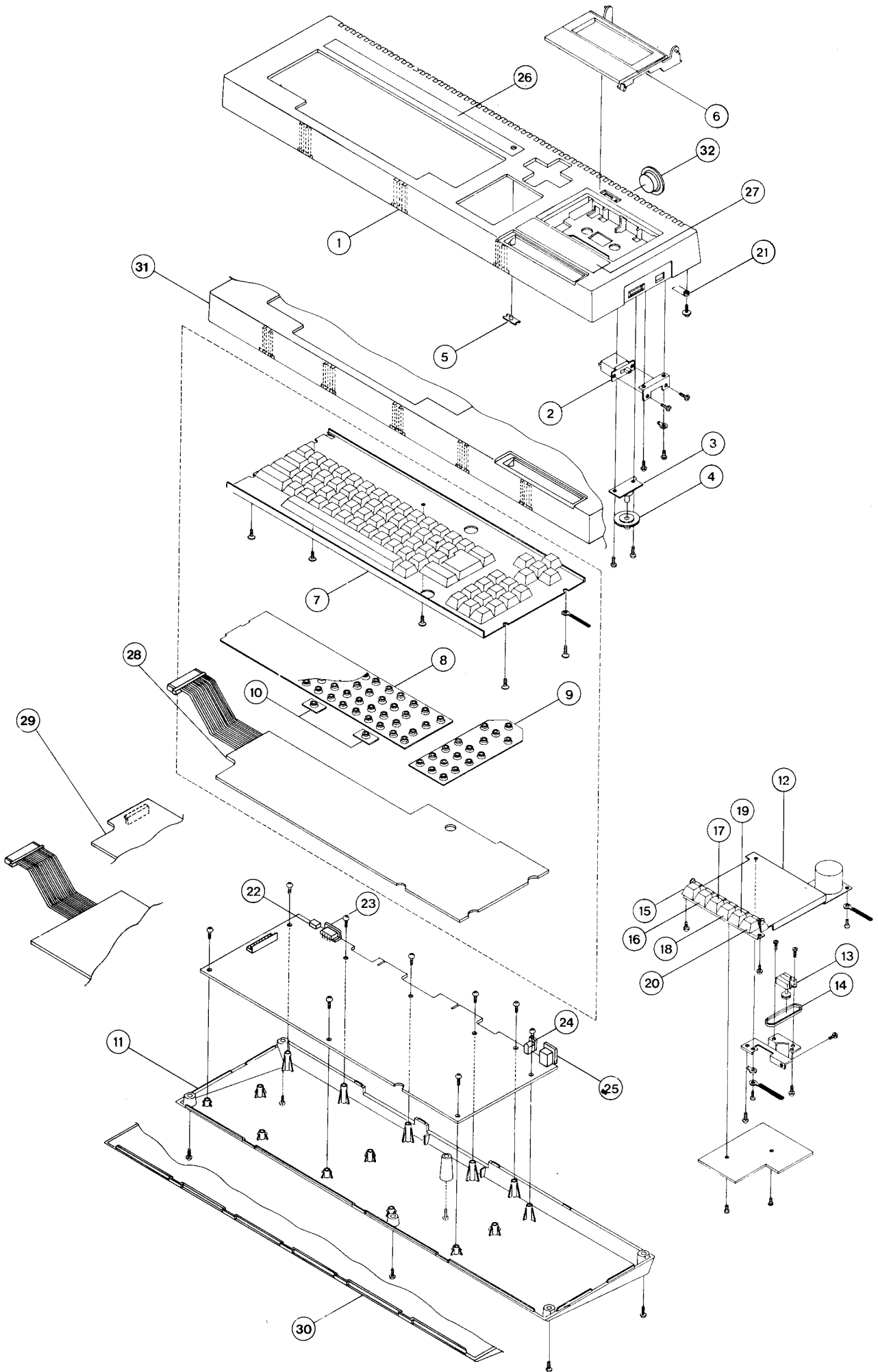

CASSETTE MECHANISM

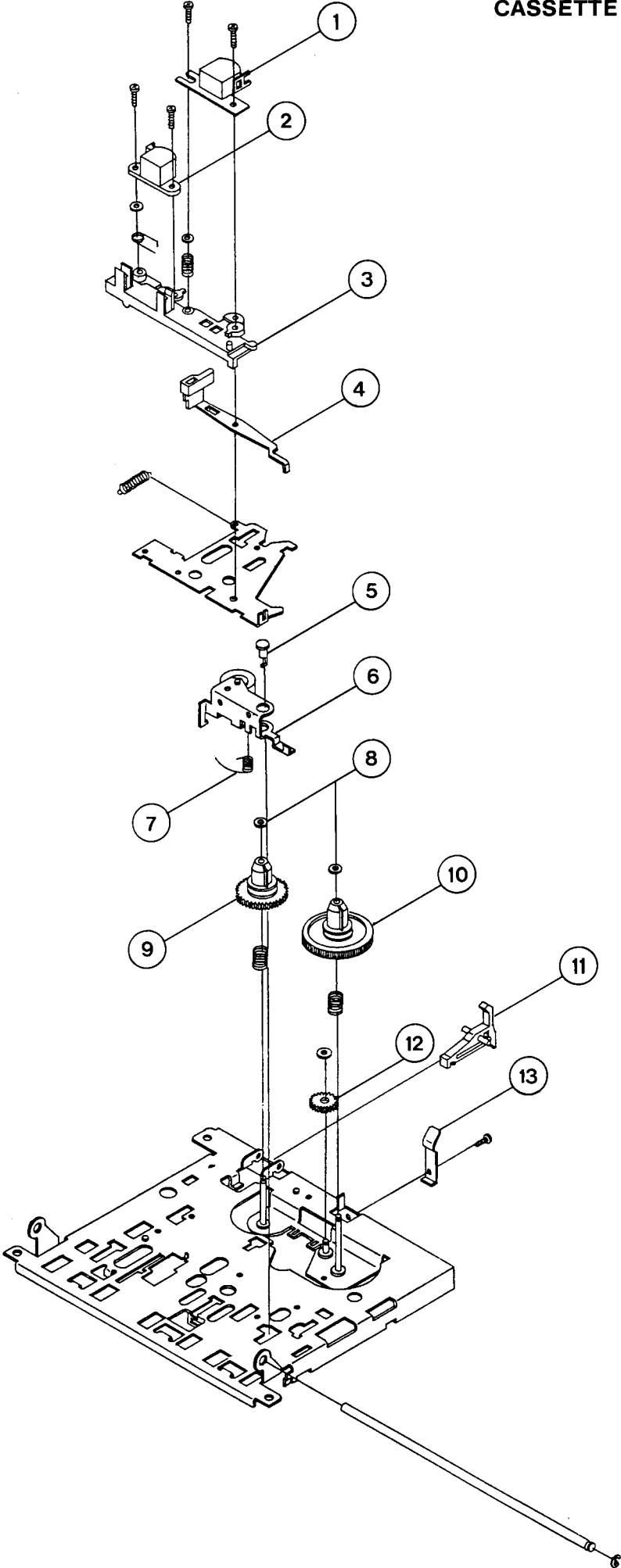

# CASSETTE MECHANISM

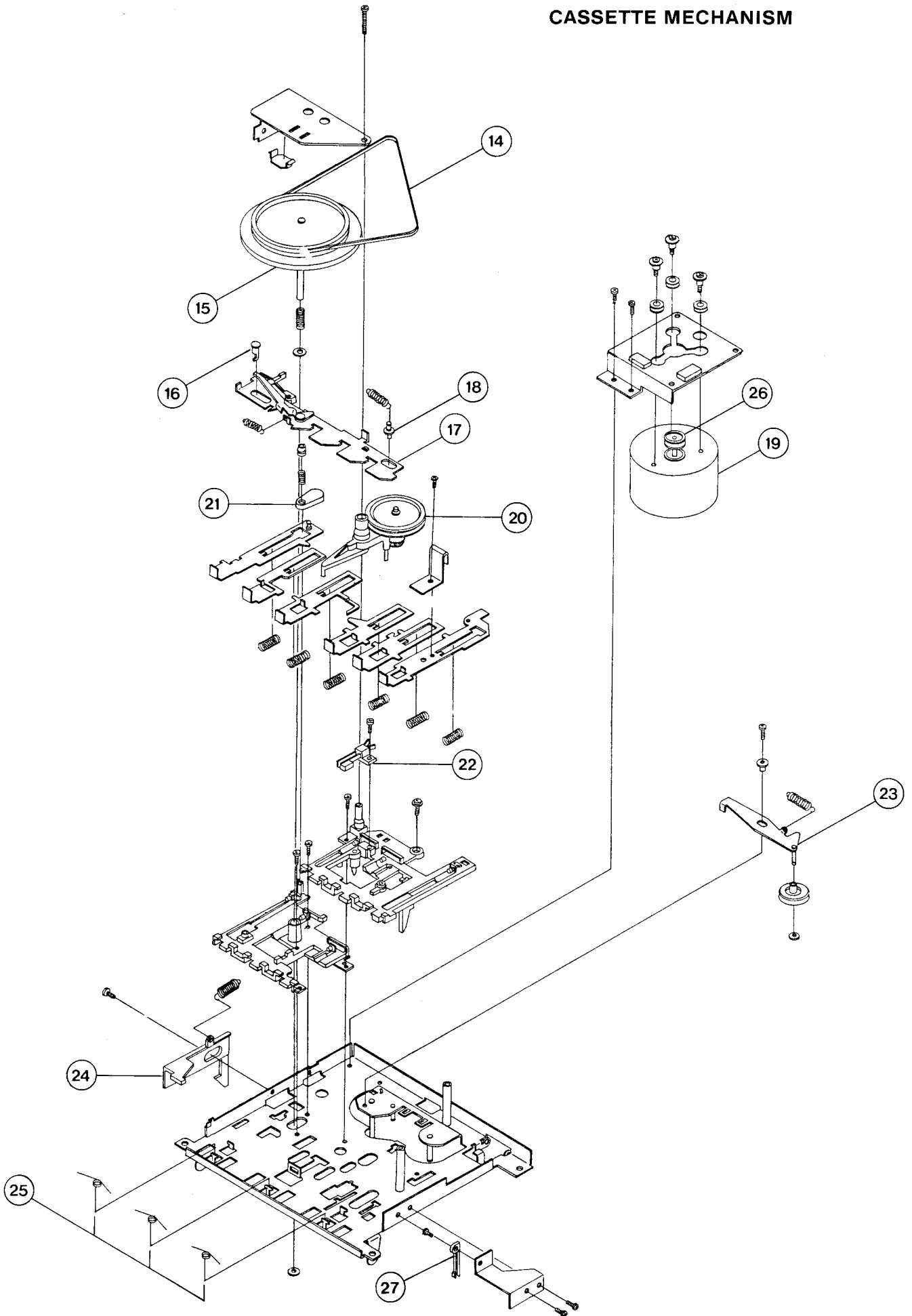

PC-1  
I-2588

## CPC464 CASSETTE MECHANISM PARTS LIST

Sym	Description	Part No.
1.	R/P Head	170201
2.	Erase Head	170202
3	Head Base	809170
4.	Auto Stop Arm	809171
5	Stopper	809172
6	Pinch Roller Assembly	809162
7	Spring Pinch Roller	809161
8.	Fibre Washer	809175
9	Rewind Spool	809160
10	Take Up Spool	809159
11	Record Safety Lever	809158
12	Idler Gear	809173
13	Back Up Spring	170203
14	Main Belt	170204
15	Flywheel	809156
16	Locking Plate Stopper *	170205
17	Locking Plate	170206
18	Spring Post Locking Plate	170207
19	Motor	170208
20	Idler Assembly	809155
21	Pause Lock Plate	809168
22	Leaf Switch	809157
23	F.F. Idler Arm Assembly	809152
24	Eject Lever Cassette Door	170209
25	Spring Cassette Buttons	170210
26	Motor Pulley	170211
27	Leaf Switch	170212

## CASSETTE DECK ALIGNMENT INSTRUCTIONS

To check cassette module independently of the C.P.U. connect 5V DC across points B(-) and C(+), and link E to G and H to F. The cassette will then operate in an audio mode.

(See page 8 - Cassette Circuit Diagram)

Equipment Required: Frequency Counter, A.V.O., V.T.V.M., Oscilloscope & Test Tape.

STEP	FUNCTION	SIGNAL IN	SIGNAL OUT	METHOD	REMARKS
1.	Cassette Azimuth Adjustment.		Monitor V.T.V.M.	1) Insert Test Tape recorded at 6kHz constant. 2) Set Volume to maximum on CPC464. 3) Connect V.T.V.M. to Pin 7 of I.C.302 to read between 330mV to 520mV. By adjusting azimuth screw on the cassette head.	Monitor switched on and fix connections.
2.	Speed Check.	Put the standard tape in the cassette mechanism.	Monitor Oscilloscope.	Check output from the tape on the oscilloscope. The range to be used is 100uS.	Speed variation $\pm 4\%$ will not affect software loading.

# CPC464 CASSETTE PCB

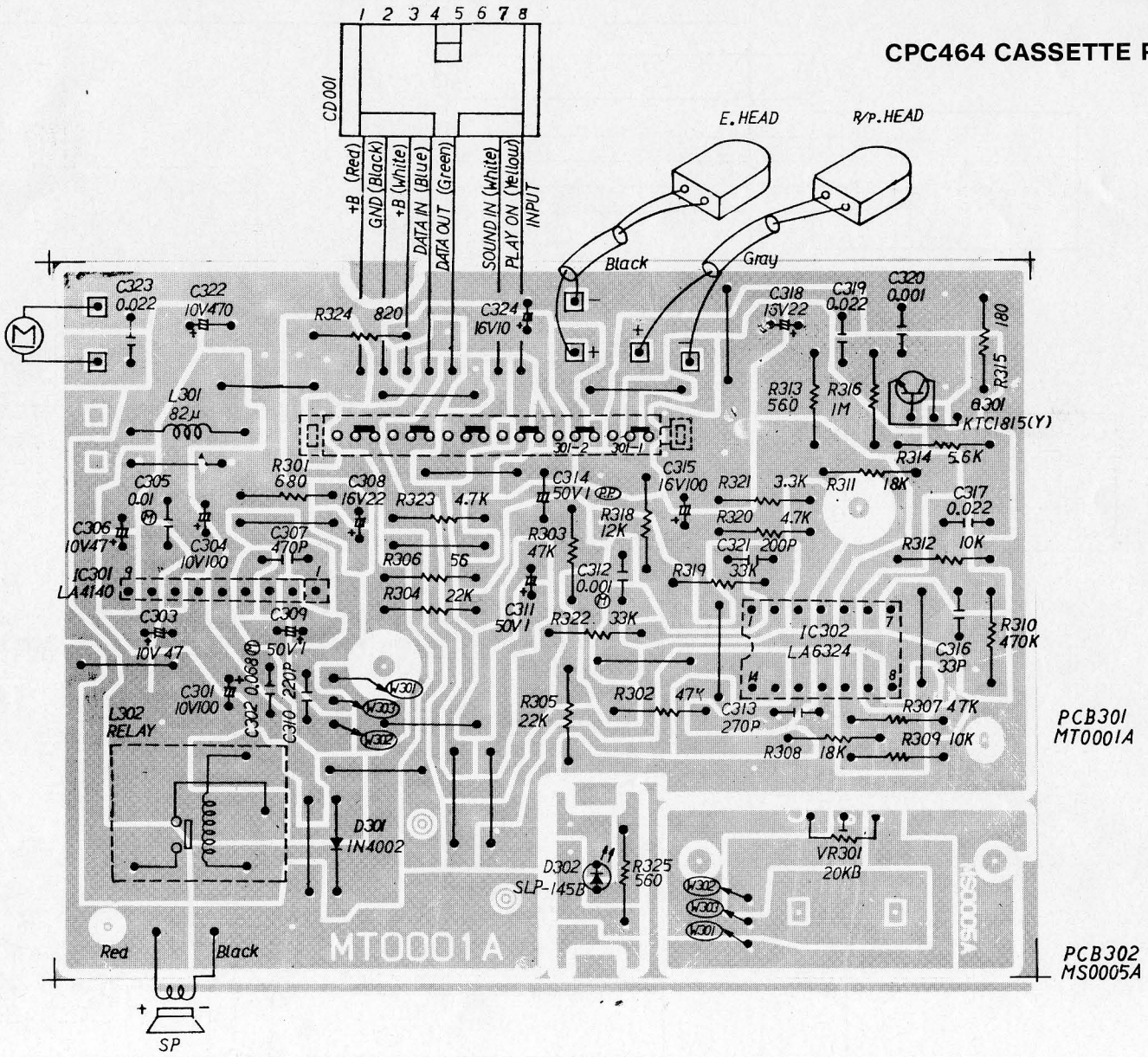
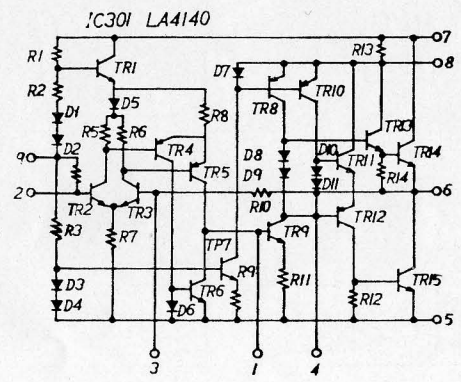
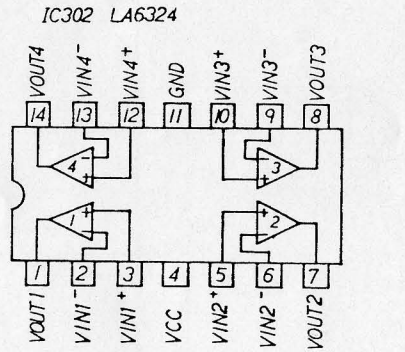

PCB301  
MT0001A

PCB302  
MS0005A





# CPC464 - BASIC HARDWARE ANALYSIS

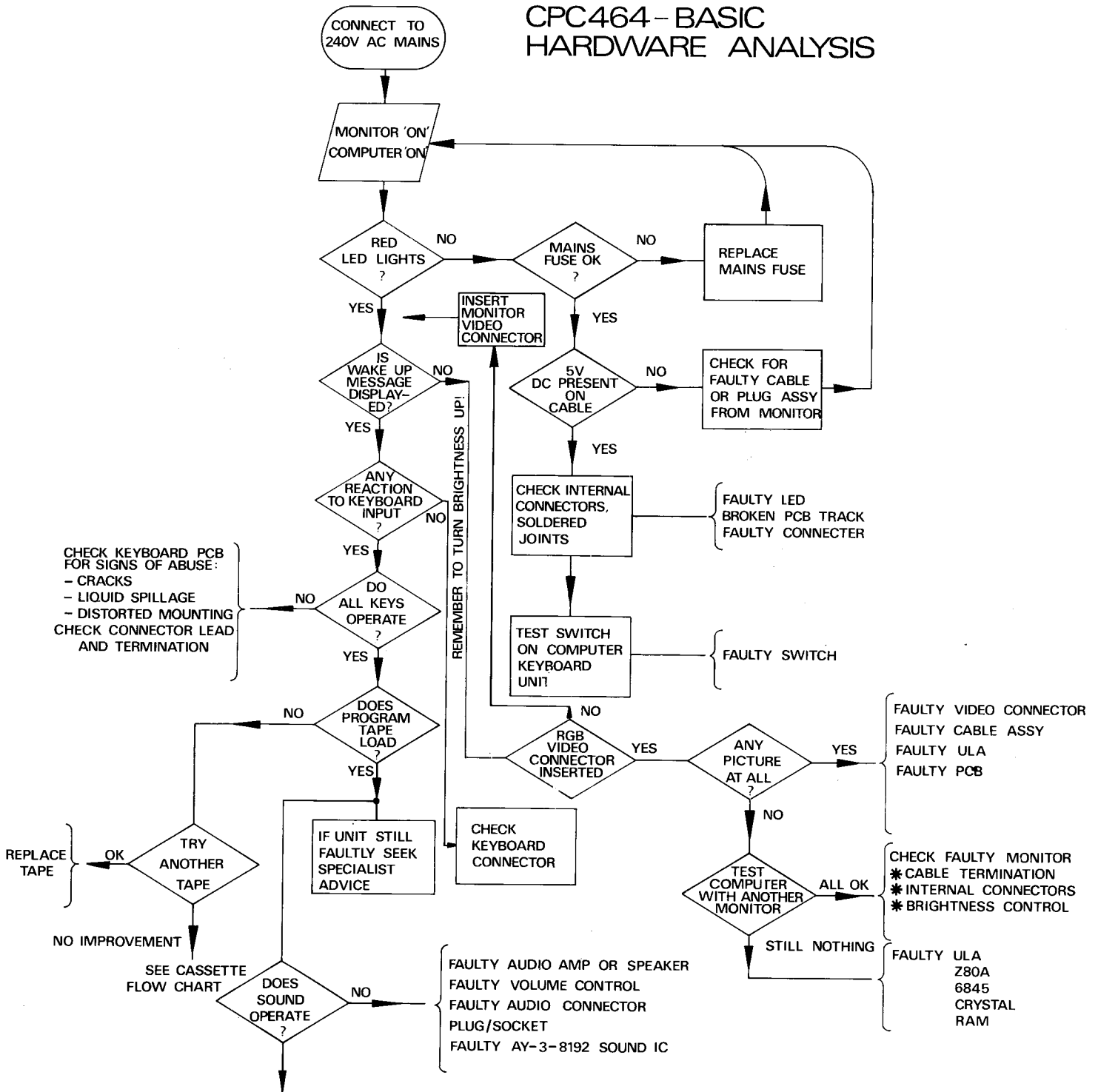

# CASSETTE & SOFTWARE ANALYSIS

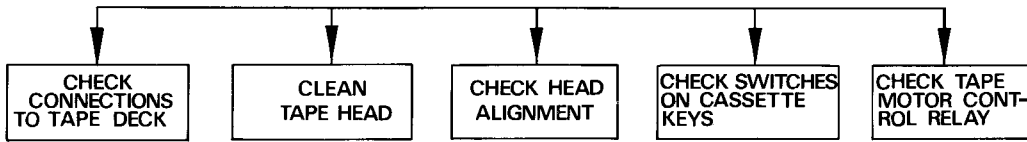

SOFTWARE LOADS, BUT WITH UNUSUAL RESULTS

POSSIBLE FAULT WITH COMPUTER BOARD: RAM FAILURE  
ULA FAILURE

Full diagnostic tests on the C.P.U. can be carried out using the Amstrad RP1 Test Pack.  
Please contact Amstrad PLC for information on same.

N.B ACTUAL 'PHYSICAL' DAMAGE TO SOFTWARE TAPE WILL PREVENT IT FROM LOADING AT ALL: IE THERE WILL BE NO 'HALF' WORKING PROGRAMS. THEY EITHER LOAD- OR THEY DON'T.

## CPC464 FUNCTION DIAGRAMS

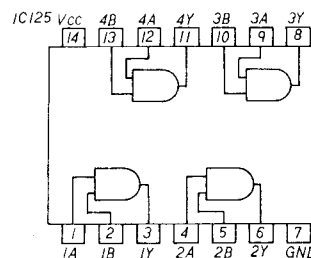
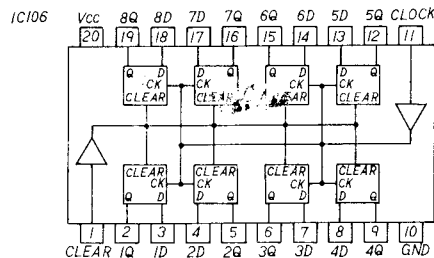
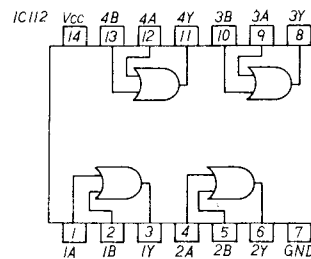
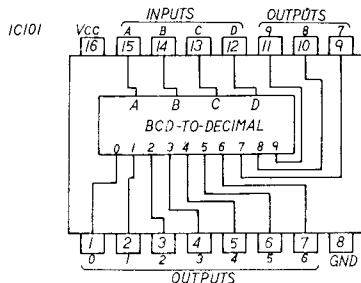
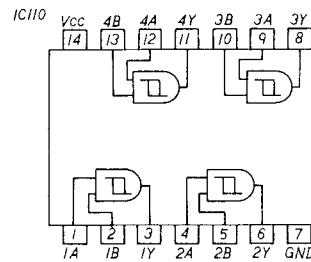
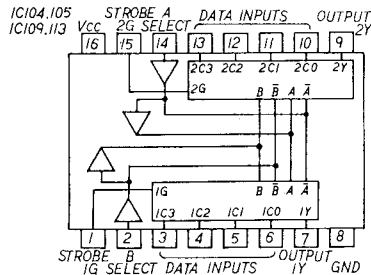
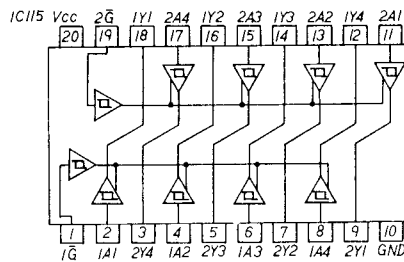
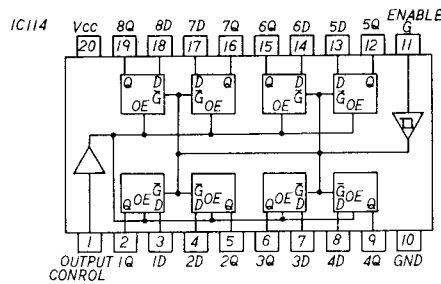

# CPC464 FUNCTION DIAGRAMS

FUNCTION FOR A MICROCOMPUTER AND IC'S

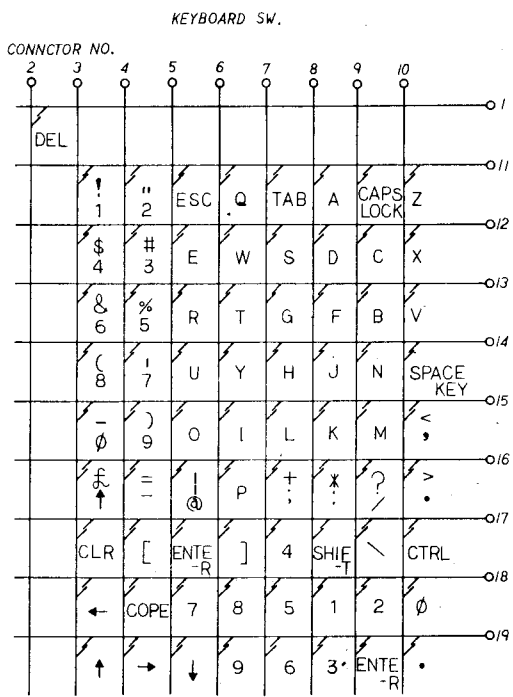
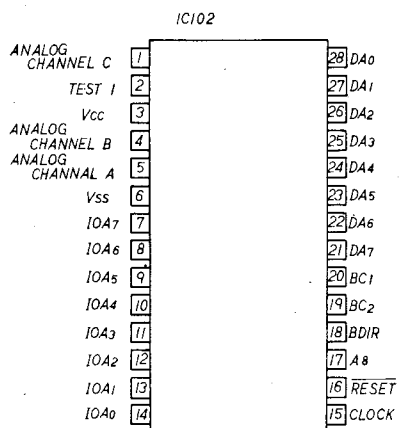
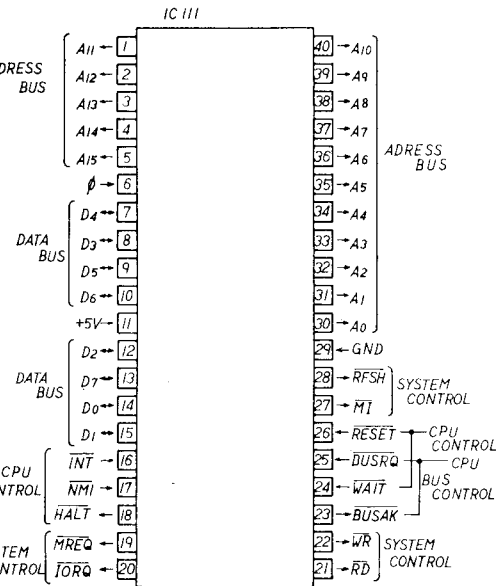
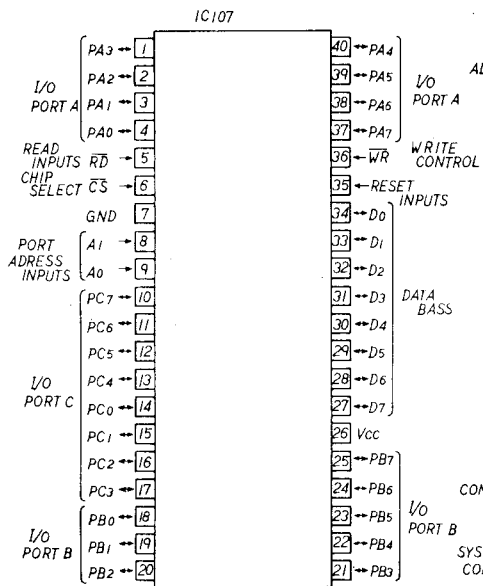
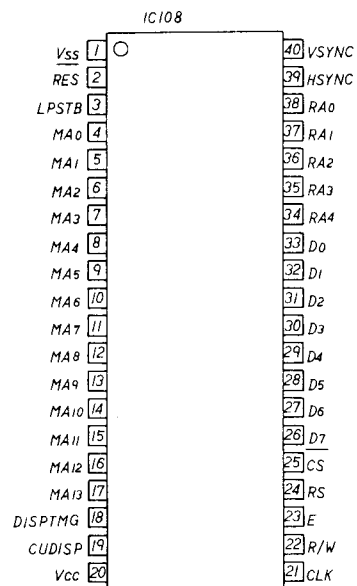





## CPC464 ELECTRICAL PARTS LIST

Value	Circuit Reference	Part No.
<b>Carbon Film Resistors (all 1/4W unless shown otherwise)</b>		
56ohm	R306	10022
68ohm	R141	10028
100ohm	R134, 140	10032
120ohm	R146-153	10034
180ohm	R315	10037
220ohm	R126, 128, 130, 136, 137	10040
330ohm	R143, 144	10044
560ohm	R154, 313, 325	10050
680ohm	R125, 127, 129, 135, 301	10052
820ohm	R324	10054
1kohm	R113, 121-123, 132, 145	10061
2k2ohm	R102-112, 124	10069
3k3ohm	R321	10073
4k7ohm	R320, 323	10077
5k6ohm	R314	10079
10kohm	R114-117, 120, 133, 142, 309, 312	10085
12kohm	R318	10087
18kohm	R308, 311	10091
22kohm	R101, 118, 119, 304, 305	10093
33kohm	R319, 322	10097
47kohm	R302, 303, 307	10101
180kohm	R317	10115
1Mohm	R316	10147
12ohm(1/2W)	R138, 139	170126
<b>Electrolytic Capacitors</b>		
1uF/50V	C309, 311, 314	20062
10uF/16V	C324	20024
22uF/10V	C308, 318	20025
47uF/10V	C101, 102, 303, 306	1400244
100uF/10V	C301, 304	20028
100uF/16V	C315	20028
470uF/10V	C322	1400248
<b>Ceramic Capacitors</b>		
33pF/50V	C316	150514
200pF/50V	C321	400107
220pF/50V	C310	400107
270pF/50V	C313	170126
470pF/50V	C307	24004
0.001uF/50V	C320	24007
0.022uF/50V	C317, 319, 323	24013
0.1uF/25V	C104-128	24020
<b>Polystyrene Capacitors</b>		
0.001uF	C312	170217
0.01uF	C305	170128
0.068uF	C302	170129
Circuit Ref.	Description	Part No.
<b>I.C.s</b>		
IC101	HD74LS145	170101
IC102	AY-3-8912	40001
IC103	TMM-23256P-1950	170102
IC104, 105, 109, 113	HD74LS153	170103
IC106	HD74LS273	170104
IC107	M5L8255AP-5	170105
IC108	HK6845SP	170106
IC110, 112	HD74LS132	170107
IC111	Z8400APS	40080
IC114	HD74LS373	170108
IC115	HD74LS244	170109
IC116	2ORAO43	40007
IC117-124	HM4864U-2	170110
IC125	ZN7400E-D3	40008
IC301	LA4140	170111
IC302	LA6324	170112

Circuit Ref.	Description	Part No.
<b>Transistors</b>		
Q101	KTC2120Y	170113
Q102, 301	KTC1815Y	170114
Q103	ZTX312L	50001
<b>Diodes</b>		
D101	SIL - IS2472 - HL	170115
D301	SIL - IN4002	400111
D302	LED - Red. SLP145B	170116
<b>Coils &amp; Tx.</b>		
L301	82uH	170117
T101	C-12	170118
<b>Jacks &amp; Connectors</b>		
J101	DIN Socket 6 Pin	170025
J102	Joystick Socket 9 Pin	170023
J103	Input/Output Socket 3.5mm R.C.A.	170022
J104	DC Jack Socket	170024
J105-112, 116	Socket I.C. 8 Pin Dual In Line	170119
J113	Socket I.C. 14 Pin Dual In Line	170120
J114, 115	Socket I.C. 20 Pin Dual In Line	170121
<b>Switches</b>		
SW301	Slide Switch R/P	170122
SW302	Power On/Off	170002
SW303	Key Board Assembly	170007
<b>Miscellaneous</b>		
VR301	Volume Control 20k	170003
RY301	Relay	170123
SP301	Speaker	170124
X101	Crystal HC-18/u 16MHz	170125

### GT64 CABINET DRAWING AND PARTS LIST

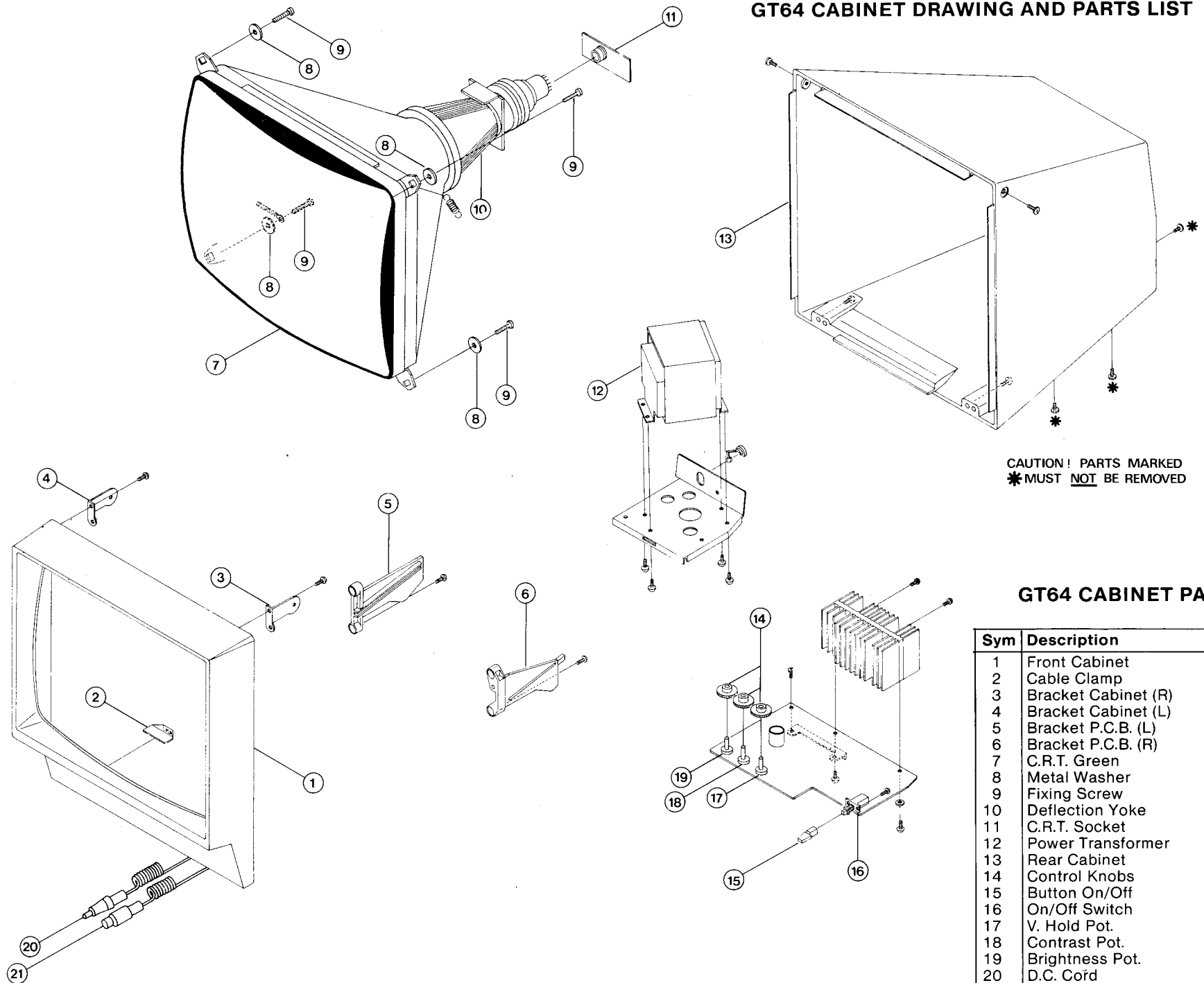

CAUTION! PARTS MARKED \* MUST NOT BE REMOVED

### GT64 CABINET PARTS LIST

Sym	Description	Part No.
1	Front Cabinet	170501
2	Cable Clamp	170502
3	Bracket Cabinet (R)	170503
4	Bracket Cabinet (L)	170504
5	Bracket P.C.B. (L)	170505
6	Bracket P.C.B. (R)	170506
7	C.R.T. Green	170507
8	Metal Washer	170508
9	Fixing Screw	170509
10	Deflection Yoke	170510
11	C.R.T. Socket	170511
12	Power Transformer	S/170512
13	Rear Cabinet	170513
14	Control Knobs	170514
15	Button On/Off	170515
16	On/Off Switch	170516
17	V. Hold Pot.	170517
18	Contrast Pot.	170518
19	Brightness Pot.	170519
20	D.C. Cord	170316
21	D.I.N. Cord	170317

# GT64 CIRCUIT DIAGRAM

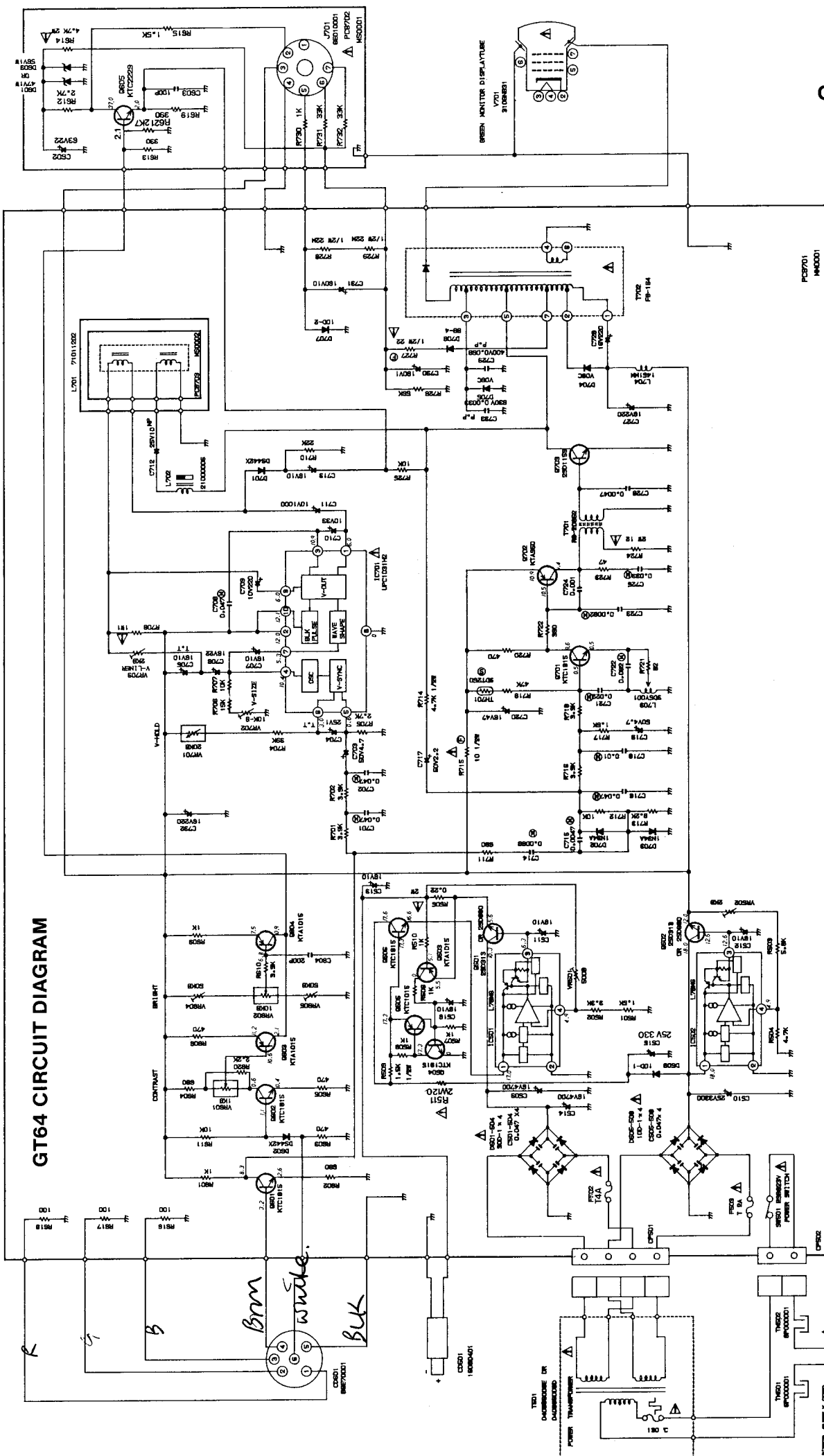

## GT64 VOLTAGE DATA

### IC701 - UPC1031H2

- 1 - 5.99V DC
- 2 - 11.98V DC
- 3 - 10.86V DC
- 4 - 10.45V DC
- 5 - 0.61V DC
- 6 - 2.93V DC
- 7 - 5.26V DC
- 8 - 0V DC
- 9 - 6.0V DC
- 10 - 11.99V DC

### IC501 - L78MG

- 1 - 20.1V DC
- 2 - 0V DC
- 3 - 5.5V DC
- 4 - 5.0V DC

### IC502 - L78MG

- 1 - 20.7V DC
- 2 - 0V DC
- 3 - 12.5V DC
- 4 - 4.9V DC

	E	B	C
Q501	5.1V DC	5.5V DC	13.6V DC
Q502	12.0V DC	12.6V DC	20.6V DC
Q605	2.0V DC	2.2V DC	39.5V DC

⚠ Note: All parts shown with either the symbol or with an 'S' prefix on the part numbers; are safety critical items and must be replaced with items having an identical safety specification. All these items may be purchased direct from AMSTRAD CONSUMER ELECTRONICS PLC.



# GT64 MAIN PCB

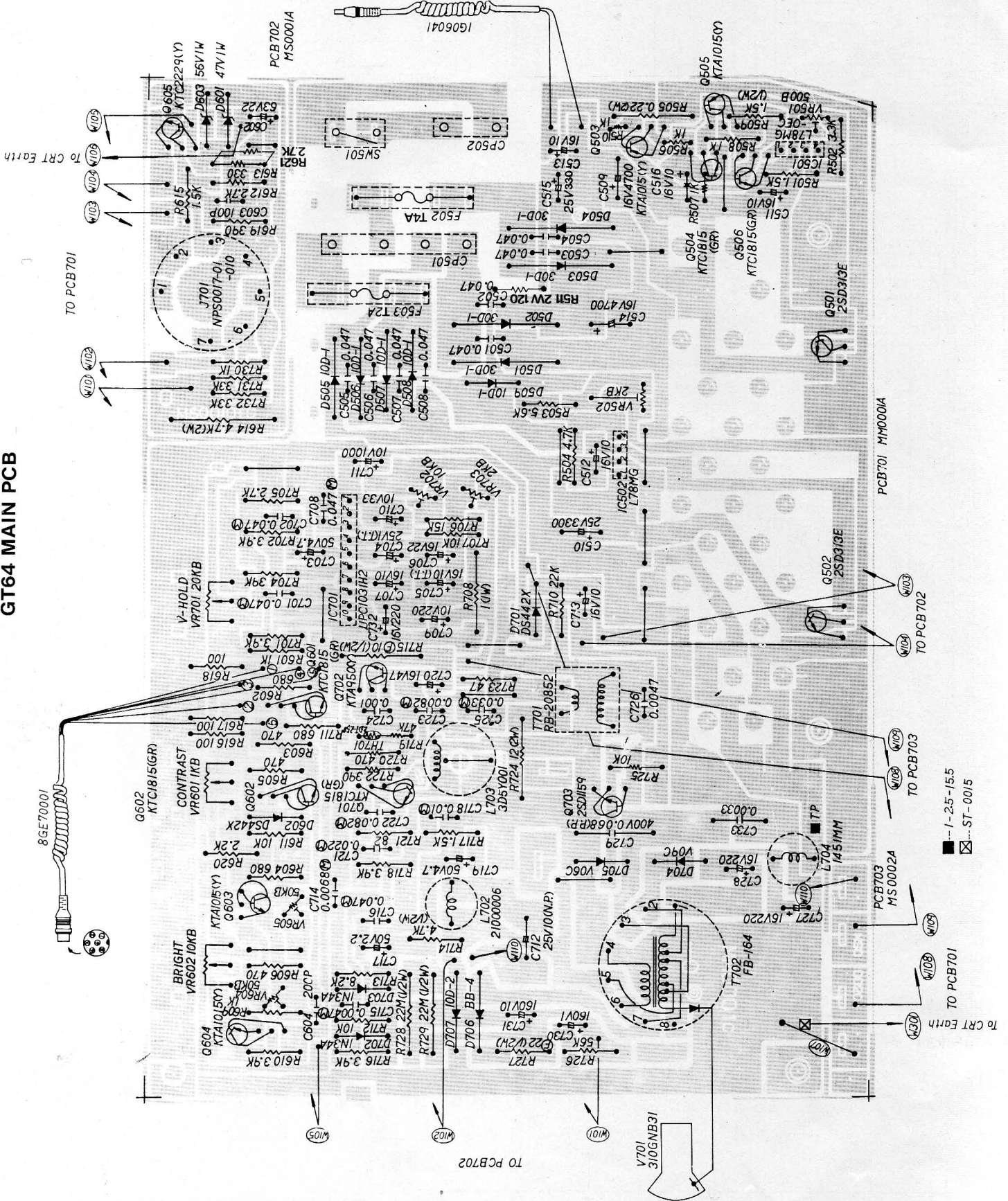

## GT64 ALIGNMENT INSTRUCTIONS

STEP	FUNCTION	SIGNAL IN	SIGNAL OUT	METHOD	REMARKS
1.	5V Adjustment.	Monitor Switched on.	A.V.O. across C519.	Adjust VR501 to obtain 5V.	
2.	12V Adjustment.	Monitor switched on.	Emitter of Q502 & Earth.	Adjust VR502 to obtain 12V.	
3.	H. Hold.	Monitor switched on.	Monitor Screen.	Connect Frequency Counter to CRT Heater. Adjust L703 to obtain 15625Hz on Frequency Counter.	
4.	V. Size & Linearity.	Page Program for Graphics.	Monitor Screen.	Top of the page can be adjusted with VR703 and Bottom of the page can be adjusted with VR702.	The adjustments are Linearity & V. Size respectively.
5.	Centering Adjustment.	Program Border - 26.	Monitor Screen.	Adjust the magnet on the back of the neck to centre the border.	

## GT64 ELECTRICAL PARTS LIST

Value	Circuit Reference	Part No.
<b>Carbon Film Resistors (¼W)</b>		
47ohm	R723	10021
82ohm	R721	10030
100ohm	R616-618	10032
330ohm	R613	10044
390ohm	R619, 722	10046
470ohm	R603-605, 606, 720	10048
680ohm	R602, 604, 711	10052
1kohm	R506-508, 510, 601, 609, 730	10061
1k5ohm	R501, 717	10065
2k2ohm	R620	10069
2k7ohm	R612, 705	10068
3k3ohm	R502	10073
3k9ohm	R610, 701, 702, 716, 718	10075
4k7ohm	R504, 714	10077
5k6ohm	R503	10079
8k2ohm	R713	10083
10kohm	R611, 707, 712, 725	10085
15kohm	R706	10089
22kohm	R710	10093
33kohm	R731, 732	10097
39kohm	R704	10099
47kohm	R719	10101
56kohm	R726	10103
<b>Carbon Film Resistors (½W)</b>		
22ohm	R727	170601
1k5ohm	R509, 615	1422126
22Mohm	R728, 729	170602
<b>Metal Film Resistors</b>		
1ohm/1W	R708	170603
0.22ohm/2W	R505	170604
4ohm7/2W	R614	170605
12ohm/2W	R724	170606
<b>Fuse Type Resistor</b>		
10ohm/½W	R715	809256
<b>Ceramic Capacitors</b>		
100pF	C603	1422144
200pF	C604	400107
0.001uF	C724	1400125
0.0047uF	C726	170600
0.047uF	C501-508	24015
<b>Electrolytic Capacitors</b>		
1uF/160V	C730	1422151
2.2uF/50V	C717	809246
4.7uF/50V	C703, 719	1400240
10uF/16V	C511-513, 516, 705, 707, 713	20024
10uF/25V	C712	20037
10uF/160V	C731	170608
22uF/16V	C706	20025
22uF/63V	C602	170609
33uF/10V	C710	170610
47uF/16V	C720	1400244
100uF/25V	C515	800370
220uF/10V	C709	170611
220uF/16V	C727, 728, 732	20029
1000uF/10V	C711	800372
3300uF/25V	C510	170612
4700uF/16V	C509, 514	170613
<b>Polystyrene Capacitors (All 50V. D.C. W.)</b>		
0.0047uF	C715	170437
0.0068uF	C714	170614
0.0082uF	C723	170615
0.01uF	C718	170439
0.022uF	C721	170616
0.033uF	C725	170617
0.047uF	C701, 702, 708, 716	170422
0.082uF	C722	170618

Value	Circuit Reference	Part No.
<b>Polypropylene Capacitors</b>		
0.0033uF/630V	C733	170619
0.068uF/400V	C729	170620
<b>Tantalum Capacitors</b>		
1uF/25V	C704	170621
Circuit Ref.	Description	Part No.
<b>I.C.s</b>		
IC501	L78MG - OEC	170446
IC502	L78MG	170446
IC701	UPC1031H2	170622
<b>Transistors</b>		
Q501, 502	2SD313	50005
Q503, 505, 603, 604	KTA1015Y	170453
Q504, 506, 601, 602, 701	KTC1815	170447
Q605	KTC2229Y	170624
Q702	KTA950Y	170448
Q703	2SD1159	170623
<b>Diodes</b>		
D501-504	Rect. 30D - IFC	170625
D505-508	Rect. 10D - IFC	1400125
D509	Rect. 10D - 1	1400125
D601	Zen. RD47FB	170626
D602, 701	Sili. DS442X - BT	1422117
D603	Zen. RD56FB	170627
D702, 703	Ger. IN34A	170628
D704	Rect. V09C	170629
D705	Rect. V06C	170630
D706	Rect. B B-4	1422116
D707	Rect. 10D-2	1400123
<b>Coils &amp; Transformers</b>		
L701	D.Y. 71011202	170510
L702	Linearity CL. 21000006	170631
L703	Horizontal C.L. 305Y001	170632
L704	C.L. 100uH	1400148
T501	Power Tx. 0866006	S/170512
T701	H.Drive Tx. RB20852	170633
T704	F.B./Lopt FB164	170634
<b>Variable Resistors</b>		
VR501	S.F. 500ohm	1422189
VR502, 703	S.F. 2k	1400230
VR601	ROT. 1k	170518
VR602	ROT 10k	170519
VR604, 605	S.F. 50k	920142
VR701	ROT 20k	170517
VR702	S.F. 10k	1422191
<b>Miscellaneous</b>		
CD501	D.C. Cord IG060401	170316
CD601	D.I.N. Cord 8GE 70001	170317
F502	3.15A (T) Fuse	88020
F503	2A (T) Fuse	1400253
TH701	Thermistor SDT-250S	170635
V701	C.R.T. 310GNB31	170507

## CTM640 CABINET DRAWING AND PARTS LIST

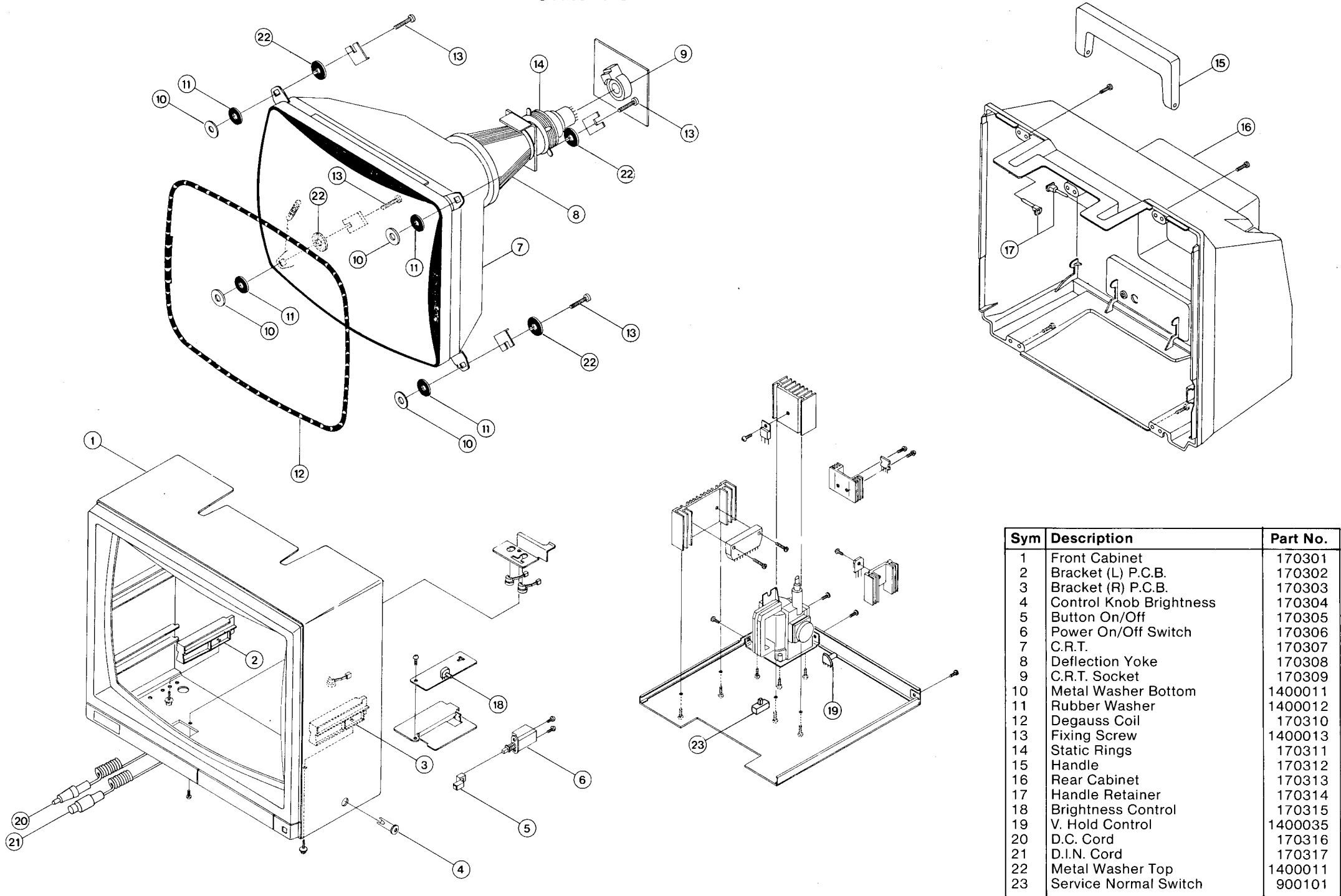

Sym	Description	Part No.
1	Front Cabinet	170301
2	Bracket (L) P.C.B.	170302
3	Bracket (R) P.C.B.	170303
4	Control Knob Brightness	170304
5	Button On/Off	170305
6	Power On/Off Switch	170306
7	C.R.T.	170307
8	Deflection Yoke	170308
9	C.R.T. Socket	170309
10	Metal Washer Bottom	1400011
11	Rubber Washer	1400012
12	Degauss Coil	170310
13	Fixing Screw	1400013
14	Static Rings	170311
15	Handle	170312
16	Rear Cabinet	170313
17	Handle Retainer	170314
18	Brightness Control	170315
19	V. Hold Control	1400035
20	D.C. Cord	170316
21	D.I.N. Cord	170317
22	Metal Washer Top	1400011
23	Service Normal Switch	900101

## CTM640 ELECTRICAL PARTS LIST

Value	Circuit Reference	Part No.
<b>Carbon Film Resistors (all 1/4W unless otherwise shown)</b>		
100ohm	R810, 901-903	10032
220ohm	R407, 416	10040
270ohm	R807, 811, 814	10042
330ohm	R401, 404, 422	10044
390ohm	R414	10046
470ohm	R505, 510	10048
1kohm	R411, 423, 432, 519, 815, 816	10061
1k5ohm	R420, 421, 441	10065
1k8ohm	R402, 403, 442	10067
2k2ohm	R410	10069
2k7ohm	R904-906	10068
4k7ohm	R426, 518	10077
6k8ohm	R415	10081
8k2ohm	R406, 418, 419	10083
10kohm	R424, 428, 429	10085
12kohm	R409	10087
15kohm	R431, 450	10089
27kohm	R425	10095
39kohm	R440	10099
47kohm	R412	10101
56kohm	R417	10103
82kohm	R430, 439	10107
180kohm	R408	10115
220kohm	R413	10117
270kohm	R504	10119
680kohm	R451	10129
<b>1ohm2/1/2W</b>	R443	170401
<b>470ohm/1/2W</b>	R445	1422125
<b>680ohm/1/2W</b>	R447	809223
<b>1kohm/1/2W</b>	R514-517	1400165
<b>1k5ohm/1/2W</b>	R448	1422126
<b>2k2ohm/1/2W</b>	R446	170402
<b>2k7ohm/1/2W</b>	R802-804	1400166
<b>180kohm/1/2W</b>	R506, 507	170403
1Mohm	R801	1400171
<b>Fuse Type Resistors</b>		
1ohm/1/4W	R521	809252
8.2ohm/1/4W	R444	170404
10ohm/1/4W	R511	809256
0.82ohm/1W	R438	1422141
2.2ohm/1W	R435, 437	1400184
<b>Cement Resistors</b>		
5.6ohm/5W	R501	1422138
15ohm/7W	R436	170417

Value	Circuit Reference	Part No.
<b>Metal Oxide Resistors</b>		
120ohm/1W	R449	170405
1kohm/1W	R503	170406
3k9ohm/1W	R505	170407
15kohm/1W	R805, 812	170408
0.22ohm/2W	R513	170409
15ohm/2W	R512	170410
33ohm/2W	R509	170411
82ohm/2W	R520	170412
100ohm/2W	R433	170413
3k3ohm/2W	R427	170414
6k8ohm/2W	R405	170415
1ohm/3W	R502	170416
<b>Electrolytic Capacitors</b>		
1uF/50V	C414	20062
1uF/160V	C419	1422151
1uF/250V	C506	1422152
4.7uF/50V	C407, 420	1400240
10uF/16V	C520	20024
22uF/10V	C437	170418
22uF/250V	C430	170419
47uF/10V	C436	170420
47uF/16V	C405, 418	1400244
47uF/50V	C512	170421
47uF/160V	C401	170422
100uF/16V	C412	20028
100uF/35V	C425	1422157
100uF/160V	C515	1400246
100uF/400V	C505	170423
220uF/35V	C507	20055
470uF/10V	C518	170424
470uF/25V	C435, 519	20044
470uF/35V	C402	1422262
1000uF/25V	C424	170425
<b>Ceramic Capacitors</b>		
22pF/500V	C416	1400217
100pF/500V	C423	1400218
130pF	C806	170426
180pF/500V	C403	170427
240pF	C804	170428
270pF/2kV	C432	170429
330pF	C803, 807	1422255
560pF/500V	C417	1400220
680pF	C802	1400213
2200pF/4kV	C513	170430
0.001uF/500V	C516	170431
0.001uF/2kV	C511, 801	1422147
0.0015uF/2kV	C510, 514	170432
0.0022uF/2kV	C502-504	1400223
0.0047uF	C508, 509	170433

## CTM640 ALIGNMENT INSTRUCTIONS

STEP	FUNCTION	SIGNAL IN	SIGNAL OUT	METHOD	REMARKS
1.	Black and White Tracking.		Monitor Screen.	1. Turn R & B Drive Controls VR804 & VR805 fully counterclockwise. 2. Turn R, G & B Bias Controls VR801, 802, 803 fully counterclockwise. 3. Set Ser. Nor. Switch to Ser. position.	Monitor connected to CPC464.
2.	Black & White Tracking.		Monitor Screen. Monitor Oscilloscope.	1. Adjust 120V at the collector of Q802 with Brightness Control on the Oscilloscope. 2. Rotate the screen control to fully counterclockwise & bring it back to obtain a dim line of one prominent colour. 3. Rotate the other two colours till a dim white line is obtained. 4. Bring Ser. Nor. Switch to Nor. position.	Monitor connected to CPC464.  If required, adjust the colour control.
3.	If no satisfactory results repeat step 2.				
4.	Vertical Size.	Program the paper edge.	Monitor Screen.	Adjust VR406 to obtain paper edge to be 145mm.	Use non magnetic ruler.
5.	Focus Adjustment.	Program the paper edge.	Monitor Screen.	Adjust Focus Control on the Flyback Tx. for maximum definition & details.	Brightness & Contrast controls set to normal viewing.
6.	5V Adjustment	Switch on the Monitor.	AVO Meter.	Connect A.V.O. across C518 & adjust VR501 to obtain 5V exactly.	
This adjustment (6) should not be disturbed under normal conditions.					
7.	Sub Brightness Control.	Switch on the Monitor.	A.V.O. Meter.	Connect A.V.O. to collector of Q802. Adjust VR402 to read 120V.	Keep Brightness Control to maximum position.
8.	Sub H. Hold & H. Hold Adjustment.	Switch on the Monitor.	Frequency Counter.	Rotate H. Hold fully counterclockwise. 1. Adjust VR404 to read 14500Hz. 2. Adjust VR403 to read 15625Hz.	Read the Meter across CRT Heater & Earth.

## CTM640 ELECTRICAL PARTS LIST

Value	Circuit Reference	Part No.
<b>Polypropylene Capacitors</b>		
0.012uF/1600V	C431	170434
0.1uF/250V	C501	1400202
0.82uF/200V	C429	170435
<b>Polystyrene Capacitors</b>		
0.0015uF	C408	170436
0.0047uF	C421	170437
0.0056uF	C415	170438
0.01uF	C413, 427	170439
0.015uF	C409	170441
0.039uF	C404	170440
0.047uF	C406	170442
0.068uF	C410, 422, 428	170443
<b>Tantalum Capacitors</b>		
1uF/16V	C411	1400225
2.2uF/16V	C426	1400226
<b>I.C.s</b>		
IC401	LA7800	1400106
IC402	UPC1378H	170444
IC501	STK7308	170445
IC502	L78MG	170446
Circuit Ref.	Description	Part No.
<b>Transistors</b>		
Q401, 402, 504, 506	KTC1815Y	170447
Q403	KTA950Y	170448
Q404	2SC2271	170449
Q405	2SD1397	170450
Q501	2SD1207	170451
Q502	2SD880Y	170452
Q503, 505	KTA1015Y	170453
Q801-803	2SC3417	170454

Circuit Ref.	Description	Part No.
<b>Diodes</b>		
D401	Sil. IS2472T	170455
D402, 403	Zen. RB11EB	1400124
D404, 506, 508	Rect. RGP-10K	1422115
D405, 407, 408	Sil. TVR 06K	170456
D406	Rect. BB-4	1422116
D501-504	Rect. IN4007	170457
D505, 507	Zen. RD 3.6FB	170458
D509	Rect. RGP 30J	170459
D510	Zen. SR2M	1400122
D511	Rect. RGP 30G	170460
D901-903	Zen. GZA6.2Y	1422114
<b>Coils &amp; Transformers</b>		
L401	Linearity Coil 1431MS	1400145
L501	Line Filter FKOB 160MH14	1400130
L502	Degauss Coil	170461
L503	Coil 47uH	170462
L801	Coil 100uH	1400148
T401	H. Drive 305Y001	170463
T402	Pin Cushion 1432MS	170464
T501	Switching Tx. 8142004	170465
<b>Switches</b>		
SW401	Slide Switch	900101
SW501	Power On/Off Switch	170306
<b>Variable Resistors</b>		
VR401	Rot. 500ohm	170315
VR402	S.F. 5k	1400227
VR403	S.F. 5k	1400227
VR404	S.F. 2k	1400230
VR405	Rot. 20k	1400035
VR406, 407	S.F. 1k	170466
VR801	S.F. 5k (R)	1400197
VR802	S.F. 5k (G)	1400198
VR803	S.F. 5k (B)	1400199
VR804	S.F. 500ohm (R)	1400200
VR805	S.F. 500ohm (B)	1400201
<b>Miscellaneous</b>		
FB401	FB/LOPT 3714004	170467
F501	Fuse 2A (T)	1400253
TH501	Degauss Element	1400195
V001	ERP.F5BOM180H C.R.T. 3701B22-TC20	170307

## CTM640 VOLTAGES

### IC401 - LA7800

- 1 - 6.35V DC
- 2 - 6.48V DC
- 3 - 0.32V DC
- 4 - 0V DC
- 5 - 0V DC
- 6 - 0.85V DC
- 7 - 3.21V DC
- 8 - 0.33V DC
- 9 - 0.93V DC
- 10 - 5.55V DC
- 11 - 0.96V DC
- 12 - 11.04V DC
- 13 - 0.89V DC
- 14 - 11.18V DC
- 15 - 12.43V DC
- 16 - 4.11V DC

### IC402 - UPC1378H

- 1 - 0V DC
- 2 - 12.74V DC
- 3 - 24.4V DC
- 4 - 0.84V DC
- 5 - 0V DC
- 6 - 24.2V DC
- 7 - 2.5V DC

### Q405 - 2SD1397

- E - 0V DC
- B - 0.1V DC
- C - 98.8V DC

### Q404 - 2SC2271

- E - 0V DC
- B - 0.3V DC
- C - 34.1V DC

### IC502 - LM78M6

- 1 - 18V DC
- 2 - 0V DC
- 3 - 5.4V DC
- 4 - 5.0V DC

CTM640 PCB

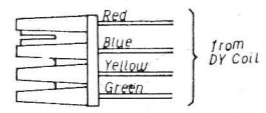
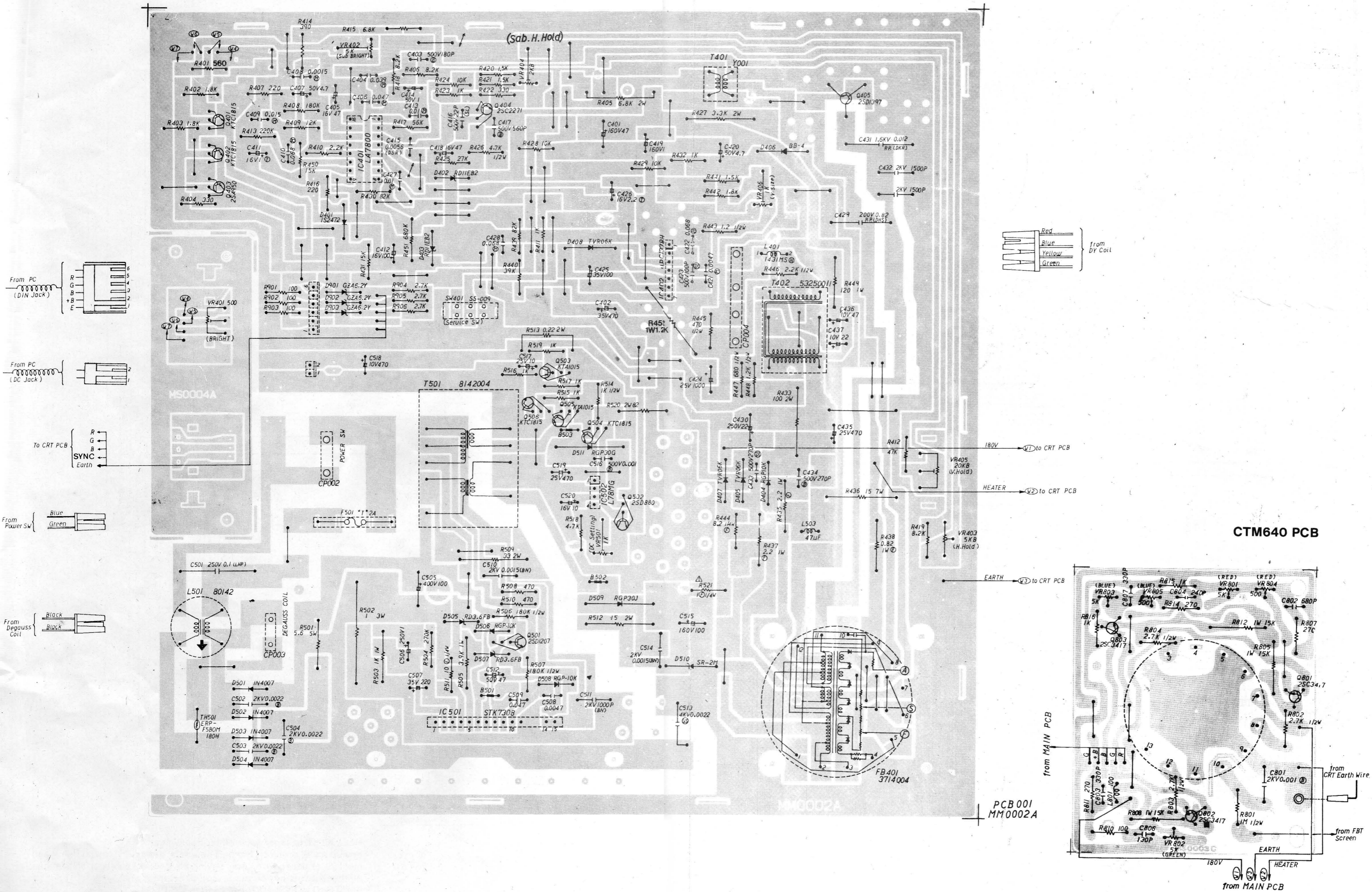

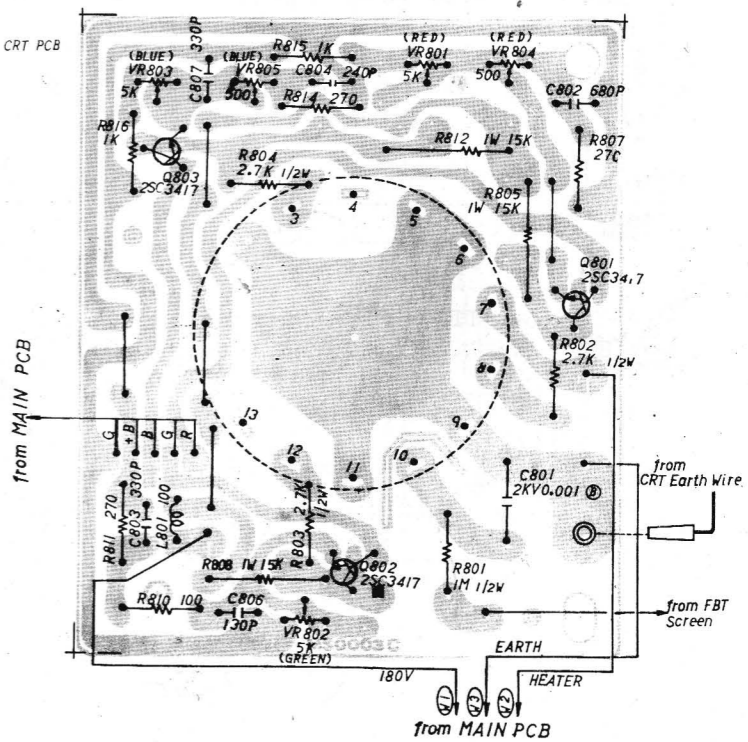

CTM640 PCB

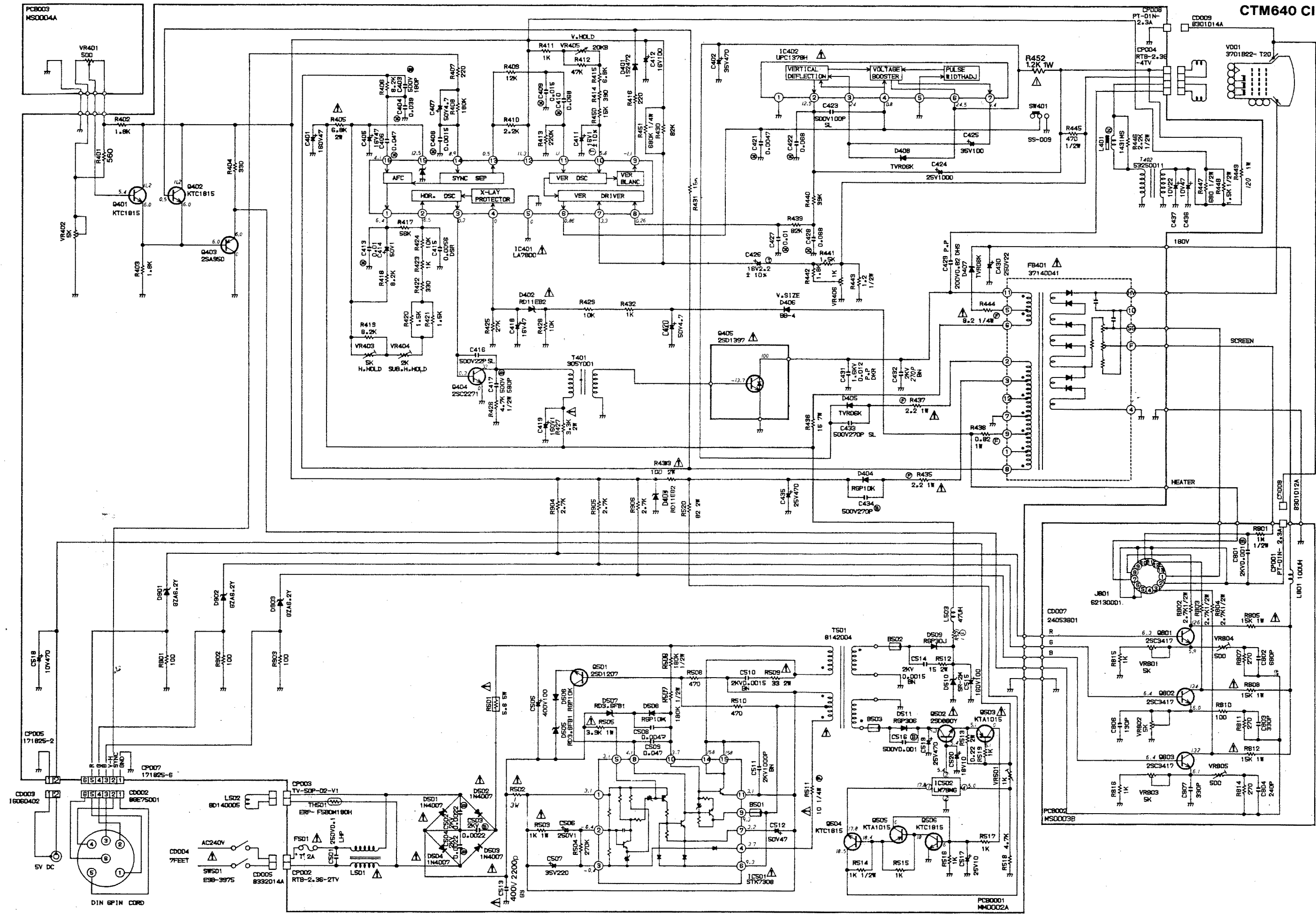

PCB001  
MM0002A

PCB002  
MS0003



Note: All parts shown with either the symbol  or with an 'S' prefix on the part numbers; are safety critical items and must be replaced with items having an identical safety specification. All these items may be purchased direct from AMSTRAD CONSUMER ELECTRONICS PLC.

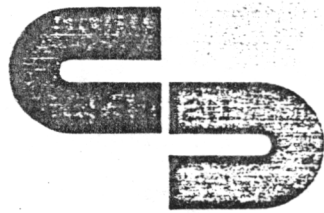

# Schneider Rundfunkwerke GmbH & Co Türkheim/Unterallgäu

Schneider Rundfunkwerke GmbH & Co · D-8939 Türkheim 1

Silvastraße 1  
Postfach 120

Fernruf (08245) 51-0  
Fernschreiber 0539128

## ERSATZTEILLISTE

GUELTIG AB 31.10.84

169380C-92210 COMPUTER MONITOR GT 64

BLATT 1

BEST-NUMMER	ARTIKELBEZEICHNUNG		ZEICH PREIS	
			POS.	0.MST
2653500-424	GEHAEUSE	GT 64	702KPA0011	114 24,00
2652900-431	FRONTRAHMEN	GT 64	701KPD0001	101 24,00
2653000-4294	RAHMEN, PLATINE (L)	GT 64	761KPA0007	105 0,80
2653100-4294	RAHMEN PLATINE (R)	GT 64	761KPA0006	106 0,80
2653300-4296	ANODENSCHIRM	GT 64	752KSA0036	108 0,60
2653200-4281	KNOPF DREH	VOLUME	732KPA0005	107 0,50
2653400-4282	KNOPF TASTE	POWER	735KPA0011	110 0,40
2653600-4162	FEDER ERDUNG	GT 64	741KUA0012	115 0,40
2653700-4067	SCHEIBE		788JSA0001	116 0,10
2654000-319	METOX 0.222W		R3110AR22J	R505 0,30
2654100-319	METOX 4.7K2W		R3D30A472J	R614 0,30
2654200-319	METOX 1/1W		R3D301010J	R708 0,20
2654300-3217	SICHERUNGS-WI	10 1/2 W	R61502100J	R715 0,60
2654400-319	METOX 122W		R3D30A120J	R724 0,30
2654500-3201	SCHIWI 22 1/2W		R011T2220J	R727 0,60
2654600-302	IC L 78 MG-OEC			IC501 3,10
2654700-302	IC L 78 MG			IC502 3,10
2654800-302	IC UPC 1031 H2			IC701 5,20
1355500-301	TRANS 2 SD 313 F		Q501,502	1,80
2174200-301	TRANS KTA 1015 Y	CV 50 RC	Q503,505,6	03,04 1,00
2173600-301	TRANS KTC 1815 Y		Q504,06,60	1,701 0,50
2654900-301	TRANS KTC 2229 Y		Q605	1,00
2655000-301	TRANS KTA 950 Y		Q702	0,60
2655100-301	TRANS 2 SD 1159		Q703	2,50
2665100-301	THERMISTOR SDT-250S		TH701	0,40
2655200-3041	DIODE 30 D-1 FC		D501-508	0,90
2655300-3041	DIODE 10 D-1		D509	0,30
2655400-3044	ZENERDIODE RD 47 FB		D601	0,90
2655500-3041	DIODE DS 442 X-BT		D602,701	0,15
2655600-3044	ZENERDIODE RD 56 FB		D603	0,90
0320700-3041	DIODE 1 N 34 A	SDD 80	D702,703	0,80
2655800-304	DIODE V 09 C		D704	0,80
2655900-304	DIODE V 06 C		D705	0,60

Banken · Banque  
Dresdner Bank Augsburg, Konto 0106609200, BLZ 72080001 · Sparkasse Mindelheim, Konto 3004, BLZ 73151750 · Hypobank Türkheim, Konto 2720107508, BLZ 73121947  
Postscheckamt München, Konto 20203-809, BLZ 70010080

Alle Geschäfte unterliegen unseren Verkaufsbedingungen  
All business transactions are subject to our terms of selling · Toutes les transactions se basent sur nos conditions de vente

Kommanditgesellschaft  
Residentenstraße 1, Memmingen, BRD 89029

Persönlich haftender Gesellschafter Schneider Elektronik GmbH,  
89029 Türkheim, Postfach 120, Memmingen, BRD 89029

Geschäftsführer  
Schneider Bernhard, Schneider Albert



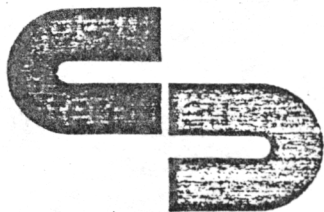

Schneider Rundfunkwerke  
GmbH & Co  
Türkheim/Unterallgäu

Schneider Rundfunkwerke GmbH & Co · D-8939 Türkheim 1

Silvastraße 1  
Postfach 120

Fernruf (08245) 51-0  
Fernschreiber 05 39 128

ERSATZTEILLISTE

GUELTIG AB 31.10.84

1693800-92210 COMPUTER MONITOR GT 64

BLATT 2

BEST-NUMMER	ARTIKELBEZEICHNUNG	ZEICH POS.	PREIS 0.MST
2656000-3043	DIODE BB 4	D706	0,80
2656100-3041	DIODE 10 D-2	D707	0,30
2656200-3253	SPULE 71011202	L701	16,80
2656300-3253	SPULE 21000006	L702	2,70
2656400-3253	SPULE 305Y001	L703	1,70
2656500-3251	SPULE 100 UH 1451 MS	L704	1,00
2656600-3243	NETZTRAFO GT 64 0866006	T501	42,00
2656700-3243	TRAFO HORIZONTAL RB-20852 GT 64	T701	1,45
2656800-3244	TRAFO ZEILEN GT 64 FB-164	T702	21,40
2656900-3328	SOCKEL BILDROEHRE NPS 0017-01-010	066E010001 J701	6,90
2657000-3272	NETZSCHALTER GT 64	0530105002 SW501	2,90
2657100-3221	DREHREGLER EVJFDAF20B13	V013013B02 VR601	1,30
2657200-3221	DREHREGLER EVJFDAF20B14	V013014B04 VR602	1,30
2657300-3221	DREHREGLER EVJFDAF20B24	V013024B01 VR701	1,30
2657400-502	HAUPTPLATINE MM0002C GT 64	13MM0001C2 701	183,00
2657500-502	BILDROEHRENANSCHLUSS MS0001C GT 64	13MS0001C2 702	16,00
2657600-502	ANSCHLUSSPLATINE MS0002C GT 64	13MS0002C2 703	1,00
2657700-360	BILDROEHRE 310GNB31 GT 64	090F120401 V701	75,00
2653800-213	STYROPOR VORN./HINT. GT 64		3,50
2653900-212	FK GT 64		7,30

PREISAENDERUNGEN VORBEHALTEN

Banken · Banque  
Dresdner Bank Augsburg, Konto 0106 609 200, BLZ 720 800 01 · Sparkasse Mindelheim, Konto 3 004, BLZ 731 517 50 · Hypobank Türkheim, Konto 2 720 107 506, BLZ 731 219 47  
Postscheckamt München, Konto 202 03-809, BLZ 700 100 80

Alle Geschäfte unterliegen unseren Verkaufsbedingungen  
All business transactions are subject to our terms of selling · Toutes les transactions se basent sur nos conditions de vente

Kommanditgesellschaft

Persönlich haftender Gesellschafter Schneider Elektronik GmbH,  
89399 Türkheim, Postfach 120, D-89399 Türkheim

Geschäftsführer  
Schneider Bernhard, Schneider Albert