

»CTM 640 Farb-Monitor«

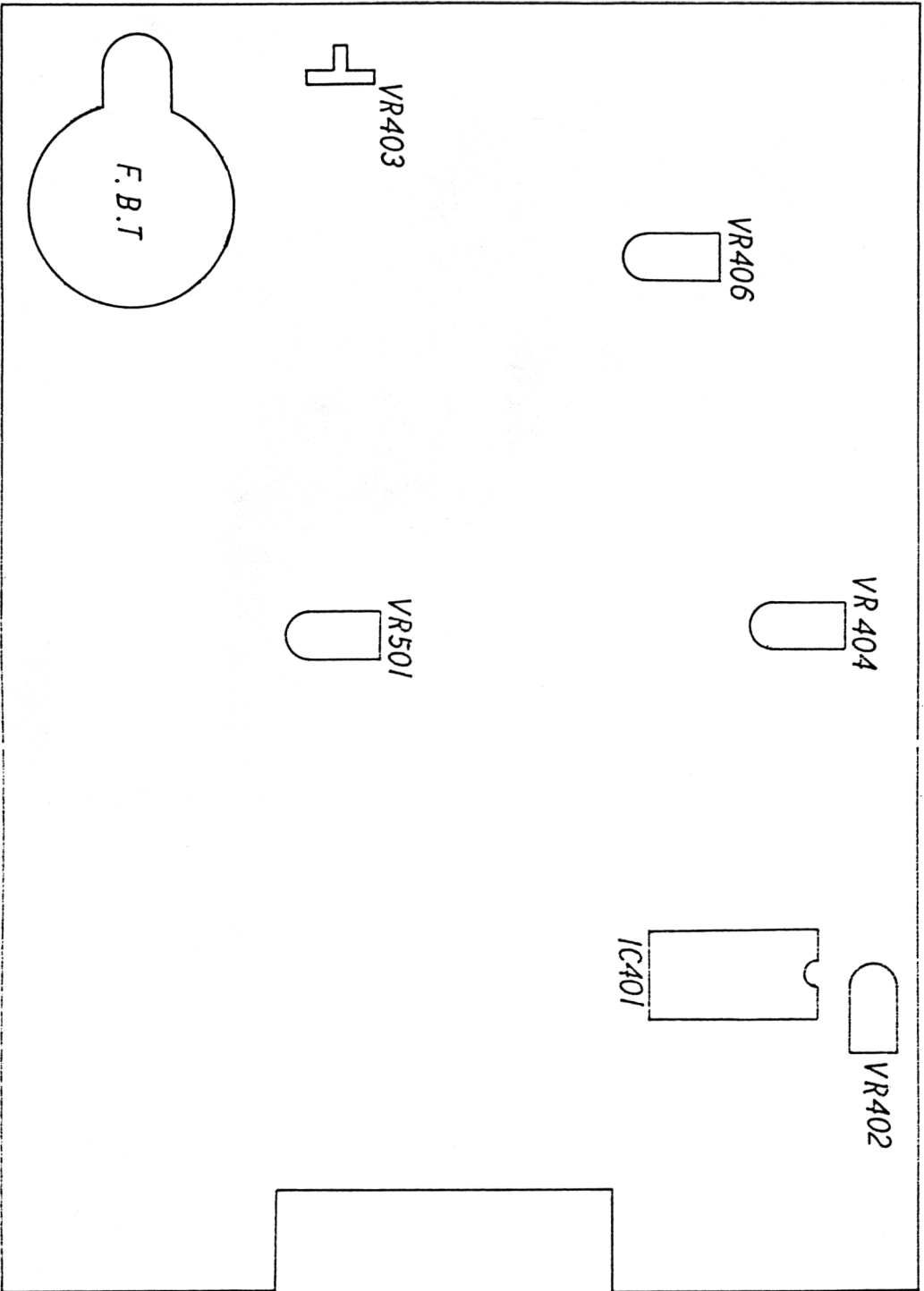



PCB001 COMPONENTS SIDE

Für alle nachfolgenden Einstellungen gilt: Netzspannung mit Regeltrafo auf 220 V einstellen.

Bildhöhen-Einstellung

Mit Regler VR 406 ist die Bildhöhe so einzustellen, daß der Bildschirm in der Höhe voll ausgeschrieben (Oberfläche des Bildes ca. 1 – 1,5 cm) und im richtigen Verhältnis zur Bildbreite ist.

Focus-Einstellung

1. Mit Focusregler am Zeilentrafo auf maximale Bildauflösung.
2. Screenregler am Zeilentrafo so einstellen, daß in Verbindung mit dem Helligkeitsregler (brightness) die Helligkeit von hell bis dunkel einstellbar wird.

5-V-DC-Einstellung

Die 5-V-Betriebsspannung wird vom Werk aus eingestellt. Bei notwendiger Nacheinstellung ist wie folgt vorzugehen:

1. Digitalvoltmeter an MP 1 (C 518) bzw. positive Spannungsversorgung für CPC 464.
2. Mit VR 501 Betriebsspannung auf 5-V-DC –0,1 V.
Vorsicht:
5-V-DC-Betriebsspannung darf nicht größer sein, um eine einwandfreie Funktion und Zuverlässigkeit der IC's im CPU 464 zu gewährleisten.

Helligkeits-Einstellung

1. Steuern Sie den Monitor mit keinem Signal an (Verbindung DIN-Stecker vom Monitor zu CPU 464 lösen).
2. Helligkeitsregler an der Monitorseite auf maximum.
3. Digitalvoltmeter an Collector von Q 802 anschließen.
4. Mit Regler VR 402 auf 120 V einstellen.

Horizontalfrequenz-Einstellung

1. Steuern Sie den Monitor mit keinem Signal an (Verbindung DIN-Stecker vom Monitor zum CPU 464 lösen).
2. Frequenzzähler an Collector von Q 404 anschließen.
3. Stellen Sie den Regler VR 403 auf Rechtsanschlag.
4. Stellen Sie nun mit dem Regler VR 404 die Frequenz von 14500 Hz ein.
5. Mit Regler VR 403 nun die Frequenz von 15625 Hz einstellen.

Schwarz-Weiß-Abgleich

Diese Einstellung ist notwendig, um die Bildröhre an die R-G-B-Endstufe anzupassen. Es wird dadurch eine gute Schwarzweißwiedergabe bei jeder Helligkeit erreicht.

1. Vor den nachfolgenden Einstellungen muß der Monitor mind. 10 Minuten in Betrieb sein.
2. Geben Sie über die CPC 464 folgendes Programm ein: BORDER 26 – Enter.
3. Stellen Sie die Regler VR 801 (Rot) und VR 803 (Blau) auf Rechtsanschlag. Stellen Sie die Regler VR 804 (Rot) und VR 805 (Blau) und VR 802 (Grün) auf Linksanschlag.
4. Serviceschalter auf Service. Helligkeitsregler auf Rechtsanschlag.
5. Die Regler VR 802 (Grün) und VR 804 (Rot) und VR 805 (Blau) soweit aufdrehen, daß gerade ein weißer Strich auf dem Bildschirm sichtbar wird.
6. Serviceschalter auf Normal.
7. Mit Regler VR 801 (Rot) und VR 803 (Blau) wenn erforderlich die Verstärkung der Blau- u. Rot-Endstufe nachstellen, so daß ein weißes Bild entsteht.
8. Bei zurückgedrehtem Helligkeitsregler eventuell die Schwarzeinstellung mit Screenregler nachstellen.

Farbreinheits-einstellung

Der Empfänger muß vor dieser Einstellung mind. 10 Minuten in Betrieb sein. Folgende Arbeitsweise wird empfohlen:

1. Geben Sie über die CPC 464 folgendes Programm ein:
BORDER 3 – Enter
INK 0,3 – Enter
INK 1,3 – Enter
es wird dadurch der Bildschirm mit einheitlichem Rot ausgeschrieben. – Helligkeit so einstellen, daß sich ein sattes Rot ergibt.
2. Prüfen Sie die richtige Lage aller Einstellungs-Komponenten (siehe Zeichnung Nr. 2).
3. Befestigungsschraube (CLAMP SCREW) an der Ablenkeinheit lösen und Ablenkeinheit nach vorn (Richtung Bildschirm) schieben, bis sich eine gleichmäßige Rotfläche ergibt.

Dynamische Farbbild-deckungseinstellung

Dynamische Farbbilddeckung (Konvergenz der drei Farbfelder an den Rändern des CRT-Schirmes) wird durchgeführt mittels genauer Einführung und Positionierung von drei Gummikeilen zwischen der Ecke des Ablenkungsspulenjochs und dem Trichter der CRT (Kathodenstrahlröhre). Dies wird wie folgt durchgeführt:

1. Schalten Sie den Empfänger ein (ON) und lassen Sie ihn 15 Minuten lang anwärmen.
2. Geben Sie über den CPC 464 die Schneider Test-Programm-Cassette ein. Verwenden Sie hierbei Programm Nr. 1 Bildlinearität und Farben. – Überprüfen Sie den Raum zwischen den Linien und Ecken des Farbbildschirms.
3. Kippen Sie das Ablenkungsspulenjoch hinauf oder hinunter und setzen Sie die Kipp-Einstellkeile (1) und (2) ein zwischen Ablenkungsspulenjoch und CRT, bis die Mißkonvergenz, beschrieben in Abbildung 3 (A), korrigiert ist.
4. Kippen Sie das Ablenkungsspulenjoch rechts und links und setzen Sie den Kipp-Einstellkeil (3) zwischen Ablenkungsspulenjoch und CRT ein, bis die in Abbildung 3 (B) gezeigte Mußkonvergenz korrigiert ist.
5. Ändern Sie wechselseitig den Freiraum dazwischen und die Tiefe des Einsatzes der drei Keile, bis eine gute Farbbilddeckungseinstellung erreicht ist.
6. Verwenden Sie einen guten Kleber, um jeden der drei Keile sicher an der Bildröhre zu befestigen.
7. Prüfen Sie die Farbreinheit und stellen Sie nach, wenn notwendig.

Konvergenzeinstellung

Der Empfänger muß vor dieser Einstellung mind. 10 Minuten in Betrieb sein.

1. Geben Sie über den CPC 464 die Schneider Test-Programm-Cassette ein. Verwenden Sie hierbei Programm Nr. 1 Bildlinearität und Farben.
2. Wählen Sie das weiße Rastermuster.
3. Sicherungsring durch linksdrehen lösen.
4. Mit den Purity Magnets durch gegenseitiges bzw. gleichzeitiges drehen die Bildlage und äußere Konvergenz einstellen.

5. Mit den 4-Pole-Magnets die horizontale und vertikale Konvergenz einstellen.
6. Mit den 6-Pole-Magnets die blau horizontale und vertikale Konvergenz einstellen.
7. Befestigungsring durch rechtsdrehen sichern.

Vertical size adjustment

Adjust the control (VR 406) so that picture fills the picture opening from top to bottom and is proportionate to the width.

Focus adjustment

Adjust focus control, on the flyback transformer, for maximum overall definition and fine detail with brightness control set at normal viewing levels.

5-V adjustment

The 5-V adjustment control (VR 501) is adjustment at the factory. However, should readjustment be required, proceed as follows:

1. Connect positive lead of voltmeter to 5-V adjust point, negative lead to chassis ground and then input AC 225 V.
2. Adjust VR 501 to obtain a 5-V reading.

Caution:

To insure proper operation and circuit reliability, do not exceed 5 V.

Sub bright adjustment

1. Set the color monitor to no-signal position.
2. Set bright control to maximum position.
3. Connect voltmeter to collector of Q 802.
4. Adjust VR 402 to obtain a 120-V reading.

Sub H-Hold and H-Hold adjustment

1. Receive the snowy station (free-run).
2. Connect frequency counter to CRT heater.
3. Rotate H-Hold control fully counter-clockwise.
4. Adjust VR 404 to obtain 14500 Hz reading.
5. Adjust H-Hold control (VR 403) to obtain 15625 Hz reading.

Color purity adjustment

The receiver must have been operating 10 minutes prior to this procedure and the face plate of the CRT must be at room temperature. The following procedure is recommended while using a Dot/Bar Generator.

1. Check for correct location of all neck components (refer to Figure 2).
2. Rough-in the static convergence at the center of the CRT, as explained in the static convergence.

3. Rotate the contrast control to maximum CCW position and rotate brightness control as for CW as possible without causing the picture to "bloom".
4. Rotate the red bias and blue bias controls to maximum CCW position. Rotate the green bias control sufficiently in a CW direction to produce a green raster.
5. Loosen the deflection yoke clamp screw and pull the deflection yoke toward the rear of the CRT.
6. Begin the following adjustment with the tabs on the round purity magnet rings set together, slowly separate the two tabs while at the same time rotating them to adjust for a uniform green stripe at the center of the CRT screen.
7. Carefully slide the deflection yoke forward to achieve green (uniform green screen).

Note:

Center purity was obtained by adjusting the tabs on the round purity magnet rings, outer edge purity was obtained by sliding the deflection yoke forward.

8. Check for red and blue field purity by reducing the output of the green bias control and alternately increasing output of red and blue bias controls and touch up adjustments, if required.
9. Tighten deflection yoke clamp screw.

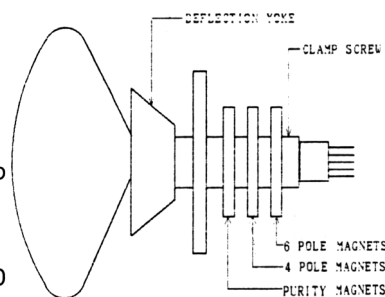

Figure 2. Picture Tube Neck Component Location

Black and white tracking

The purpose of this procedure is to adjust the biases applied to the picture tube to obtain good black and white picture production at all brightness levels while, at the same time achieving maximum useable brightness.

1. Rotate the Red and Blue Drive control fully CW and then back CCW center of their rotation ranges.
2. Rotate the Green, Red and Blue Bias controls to the full CCW end of their rotation ranges.
3. Set normal-service switch to service position. Adjust the

voltage of test point (collector of green output transistor on CRT PCB) to DC 120 V with brightness control. Voltage should be measured with oscilloscope.

4. Rotate the screen control to the full CCW end of its rotation range. Then, rotate it CW until a dim line of one pronounced color (green, red or blue) is obtained.
5. The other two color bias controls must be rotated CW until a dim white line is obtained.
6. Set normal-service switch to normal position.
7. If required, touch-up adjustment of the Red and Blue Drive controls to produce a uniform monochrome picture.
8. Rotate the brightness and contrast controls fully CCW.
9. Rotate the brightness control CW until a dim raster is obtained.
10. If the screen does not display good while uniformity, step 2 through 10 of this procedure must be repeated.

Dynamic convergence adjustment

Dynamic convergence (convergence of the three color fields at the edges of the CRT screen) is accomplished by proper inser-

tion and positioning of three rubber wedges between the edge of the deflection yoke and the tunnel of the CRT. This is accomplished in the following manner.

1. Switch the Receiver on and allow it to warm up for 15 minutes.
2. Apply crosshatch pattern from Dot/Bar Generator to receiver. Observe spacing between lines around edges of CRT screen.
3. Tilt the deflection yoke up or down, and insert tilt adjustment wedges (1) and (2) between the deflection yoke and the CRT until the misconvergence illustrated in Figure 3 (A) has been corrected.
4. Tilt the deflection yoke right and left, and insert tilt adjustment wedge (3) between the deflection yoke and the CRT until the misconvergence illustrated in Figure 3 (B) has been corrected.
5. Alterately change spacing between, and depth of insertion of the three wedges so proper dynamic convergence is obtained.
6. Use a strong adhesive tape to firmly secure each of the three wedges to the funnel of the CRT.
7. Check purity and readjust, if necessary.

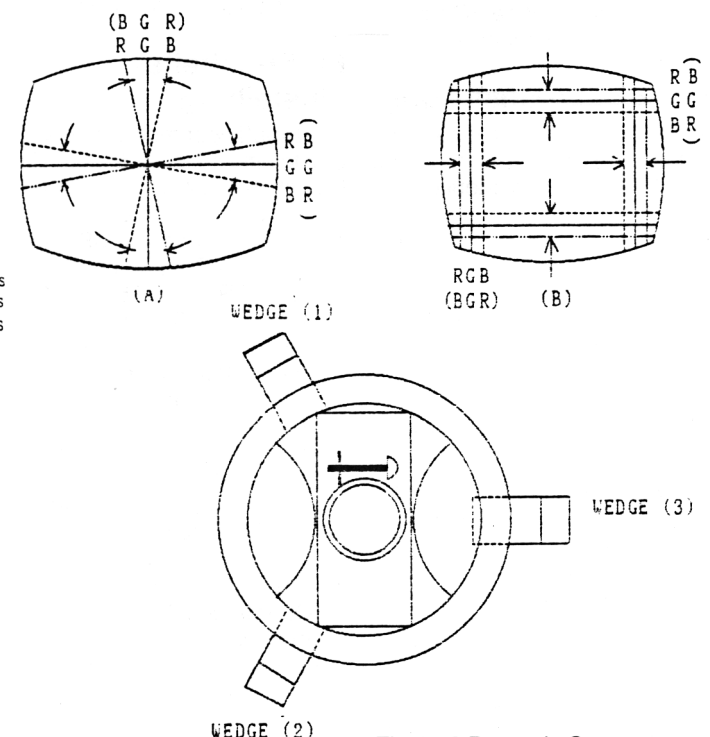
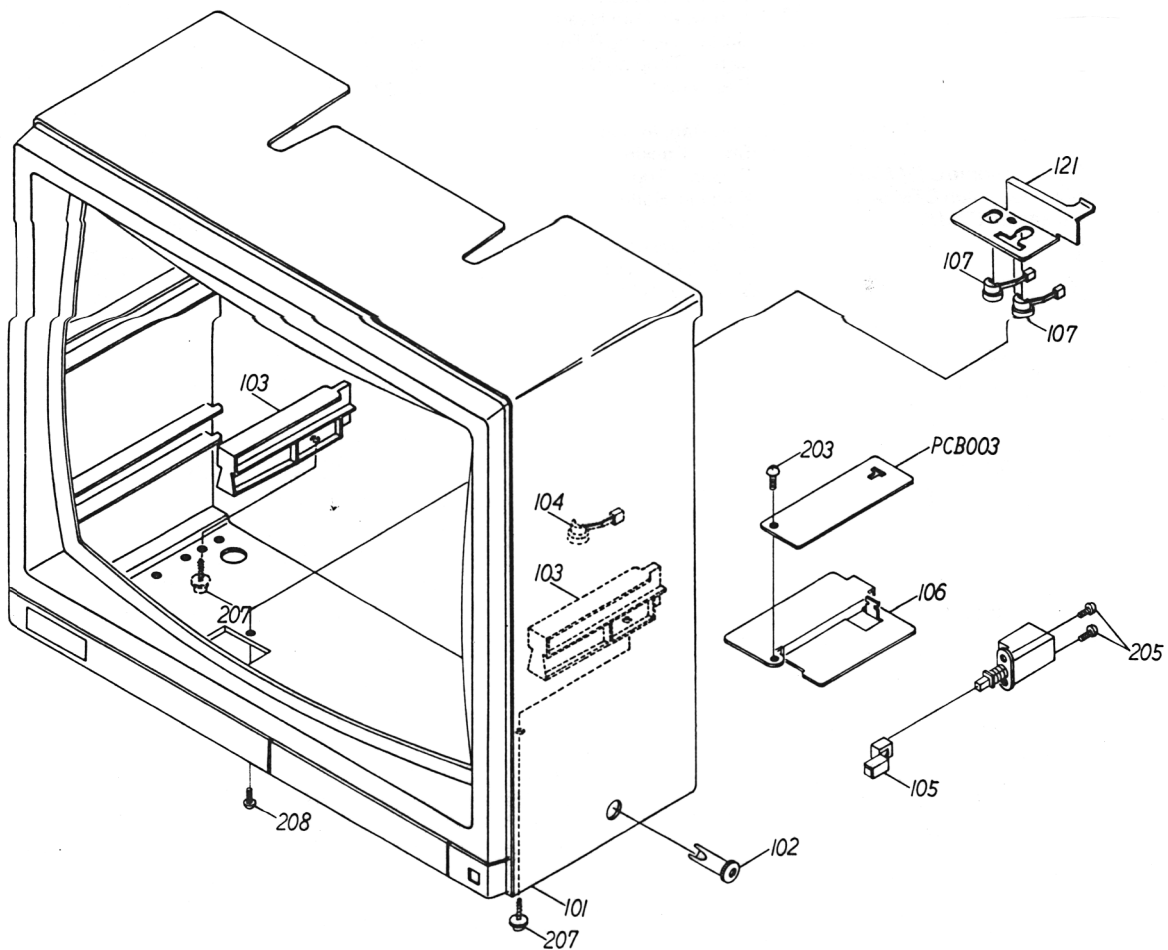
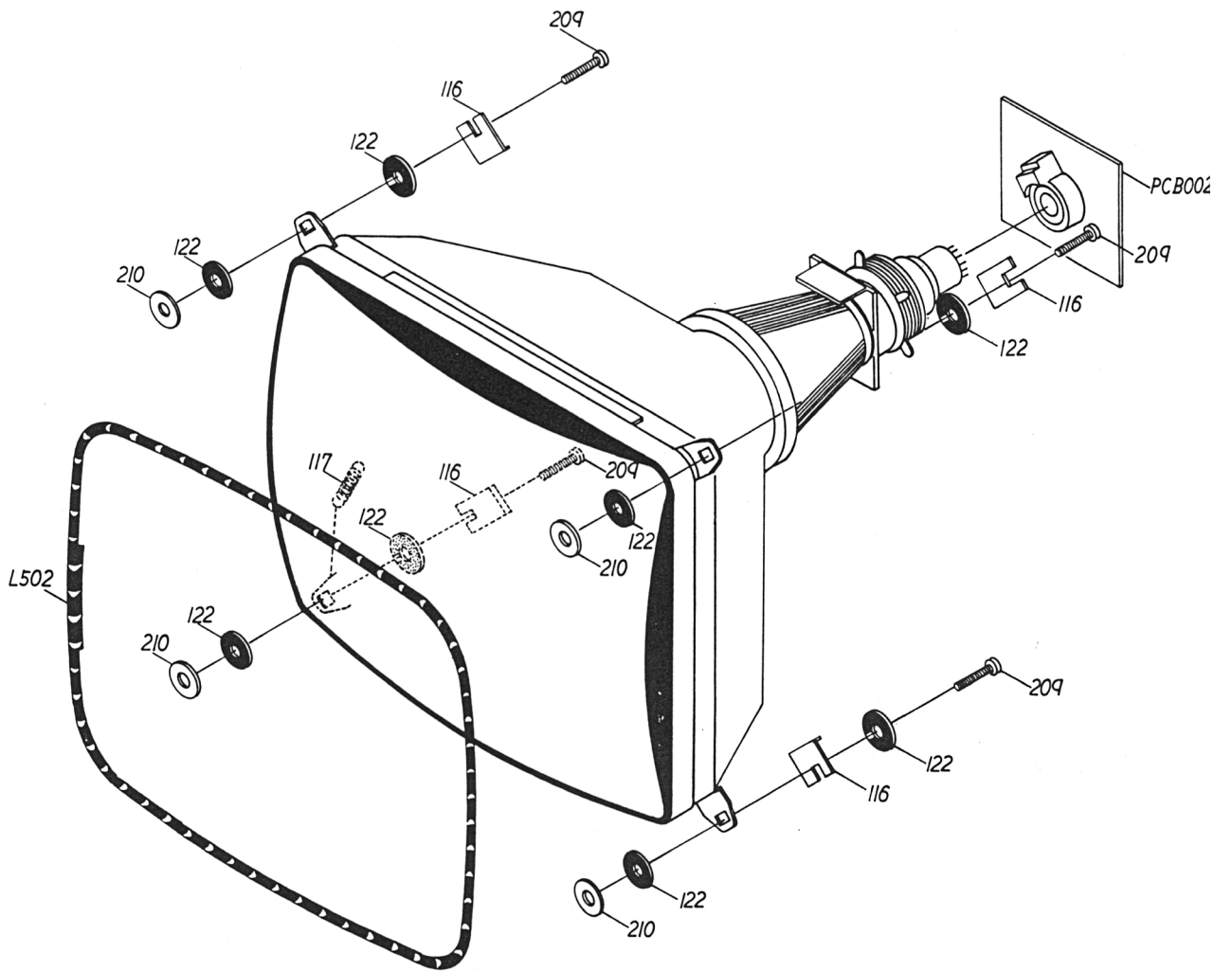
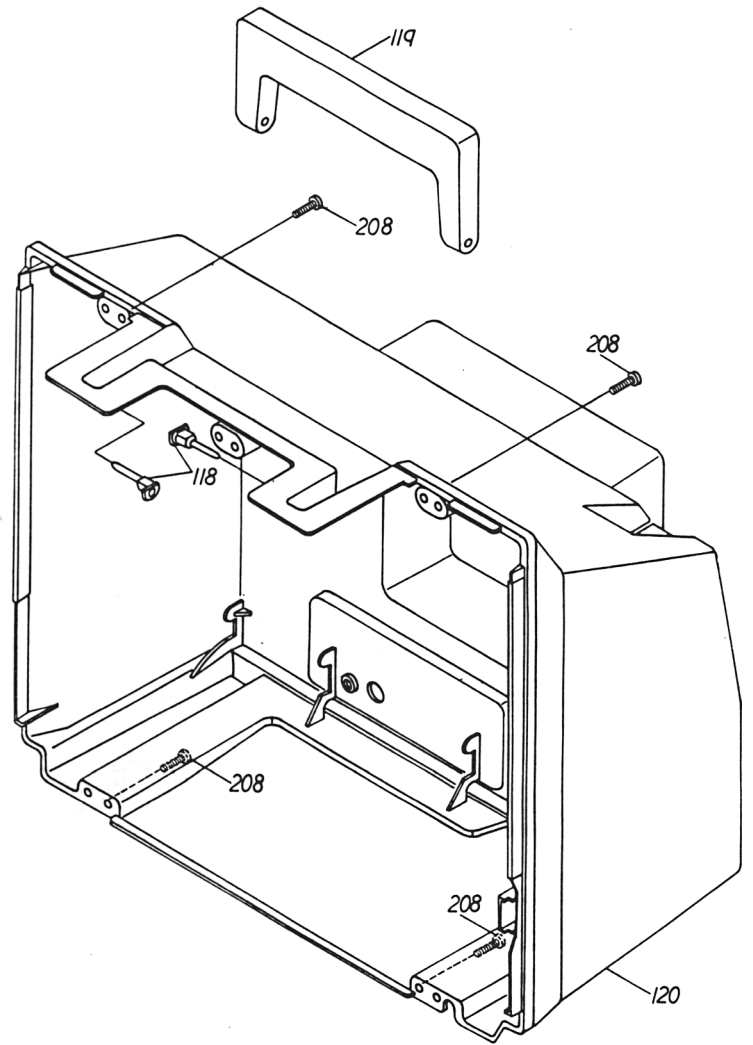
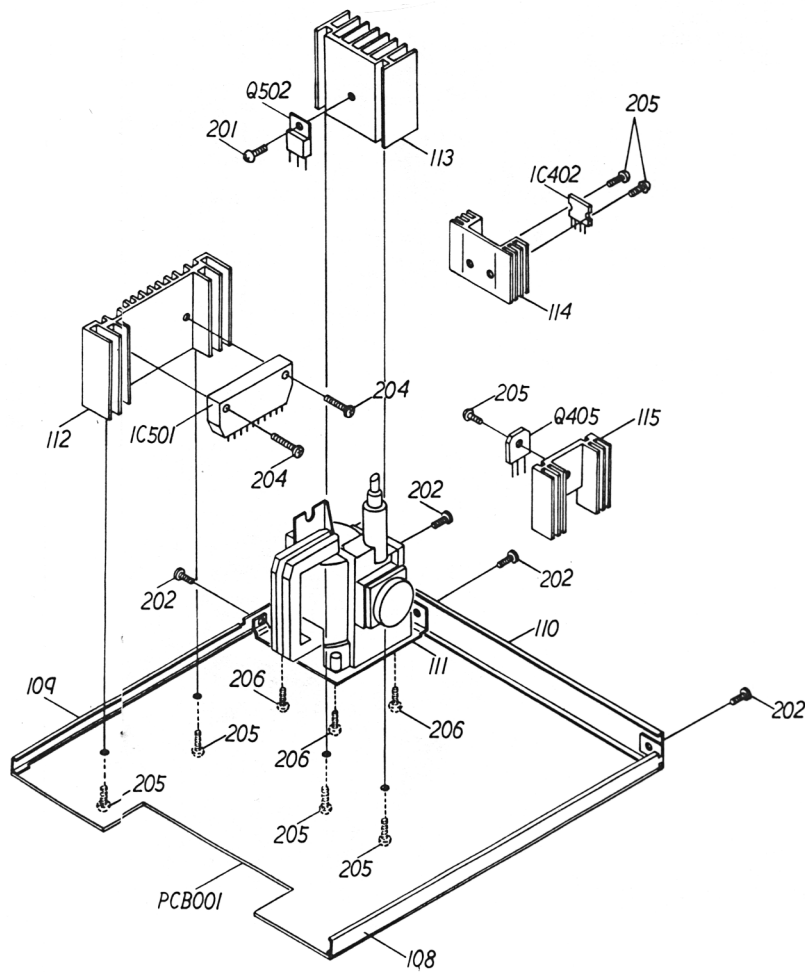

Figure 3 Dynamic Convergence Adjustment

Ersatzteilliste für CTM 640 Farb-Monitor
Parts List for Model Type CTM 640 Colour Monitor

Best.-Nr. Part No.	Bezeichnung	Description	Teile-Nr. Part No.	Zeich.-Pos. Ref.-No.	
2657800-431	Frontrahmen	Cabinet, Front Cabinet, Holder Plate, Decoration Plate, Brand	701KPB0003 709KPA0004 7230000465 7231970020	101	
2657900-4281	Knopf Dreh	Knob, Control	732JPA0033	102	
2658000-4294	Halter Platine	Holder, P.C.B.	769JPA0001	103	
	Kabelstopper	Cord Stopper	8931364000	104	
2658100-4282	Knopf Taste	Button, Push	735JPA0096	105	
2658200-4294	Rahmen, Platine	Frame, Volume P.C.B.	761KSA0047	106	
	Kabelstopper	Cord Stopper	8931120000	107	
	Winkel Platine (R)	Angle, P.C.B. (Right)	761JSA0018	108	
	Winkel Platine (L)	Angle, P.C.B. (Left)	761JSA0019	109	
	Winkel Platine	Angele, P.C.B. (Back)	761JSA0099	110	
	Winkel	Angle, P.C.B. (F.B.T.)	761JSA0021	111	
	Kühlkörper	Heat Sink, OS	763JAA0033	112	
	Kühlkörper	Heat Sink, OS	763JAA0032	113	
	Kühlkörper	Heat Sink, OS	763JAA0025	114	
	Kühlkörper	Heat Sink, OS	763JAA0023	115	
	Kühlkörper	Washer, C.R.T.	769JSA0004	116	
	Kühlkörper	Spring, C.R.T. Earth	741KUA0013	117	
2658300-4139	Halter Griff	Holder, Handle	769JPA0004	118	
2658400-438	Handgriff	Handle	705KPA0001	119	
2658500-431	Gehäuse	Cabinet, Back Sheet, Rating	702KPA0025 7220000142	120	
		Bracket, Cord	762KSA0027	121	
		Sheet, C.R.T. Support	800JR00003	122	
		Screw, Bind	M3×10	8102230A01	201
		Screw, Bind	M3×6	8102230601	202
		Screw, Tap Tite (S)	M3×8	8107630802	203
		Screw, Tap Tite (P)	M3×18	8110130A84	204
		Screw, Tap Tite (P)	M3×10	8110630A04	205
		Screw, Tap Tite (P)	M3×12	8110630A24	206
		Screw, Washer Head B	M4×12	8117E40A21	207
		Screw, Tapping B Truss	M4×16	8117540A62	208
		Screw, Tapping B1	M5×40	8119150D05	209
		Plain Washer	5×22×1.6t	82A50B2161	210
		Poly Bag, AC Cord	791KHA0009	-	
		Sheet, Packing	791KHA0019	-	
2658600-213	Styropor vorne CTM 640	Packing, Top	792KHA0044	-	
2658700-213	Styropor hinten CTM 640	Packing, Bottom	792KHA0045	-	
2658800-212	Faltkasten CTM 640	Gift Box	793KCD0069	-	
		Crimping Sleeve	899P550000	-	
		Band, Cord Clamp	8995125000	-	
		Band, Cord Clamp	8995167000	-	





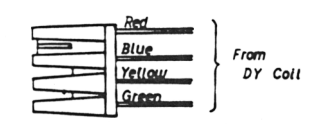
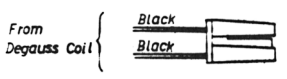
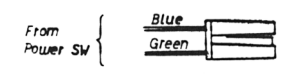
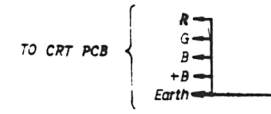
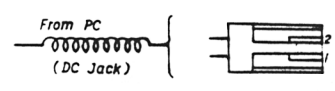
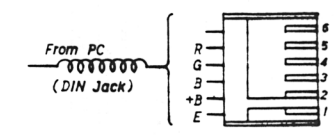
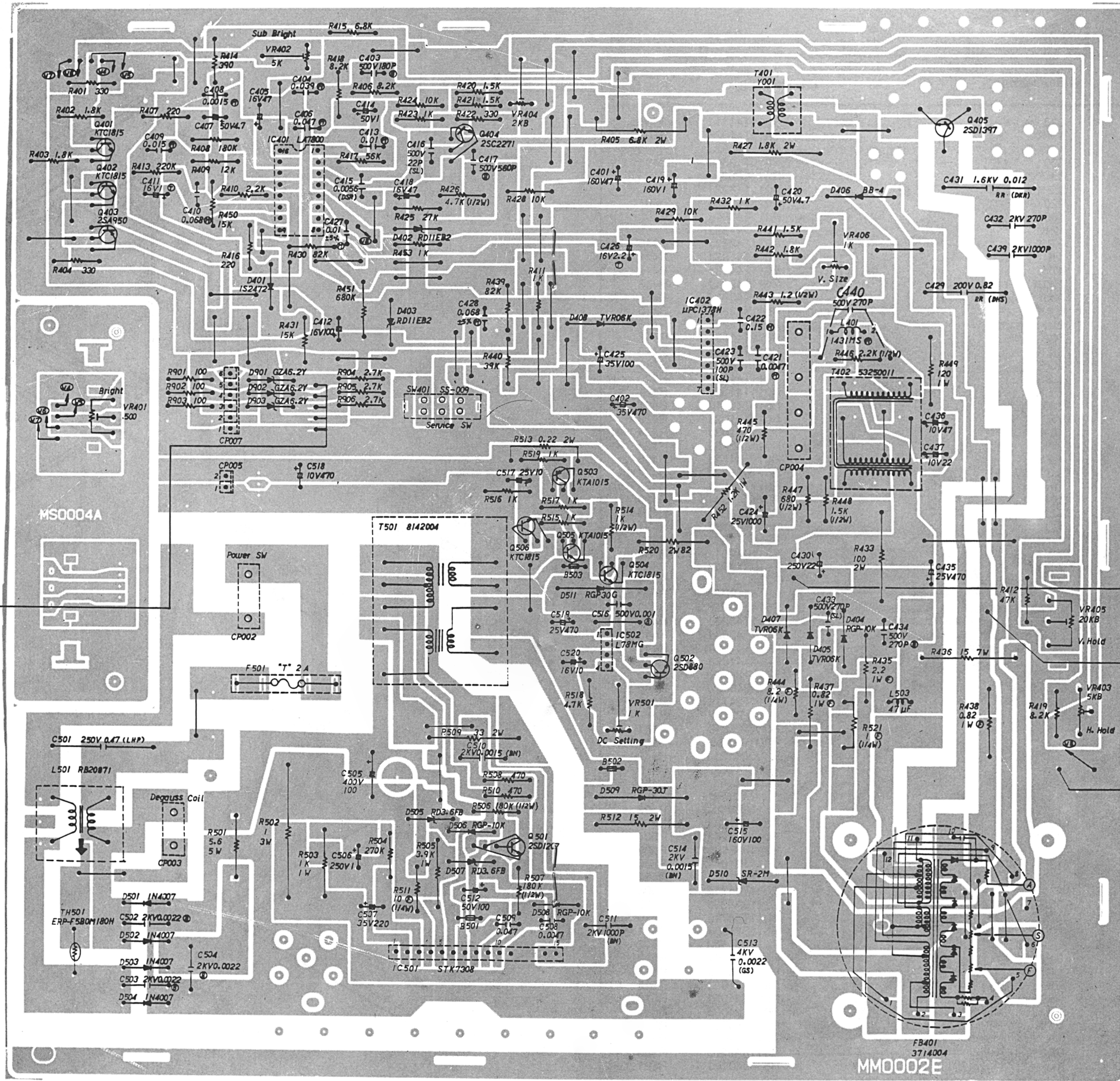

180V $\text{\textcircled{V}}$ TO CRT PCB

HEATER $\text{\textcircled{V}}$ TO CRT PCB

EARTH $\text{\textcircled{V}}$ TO CRT PCB

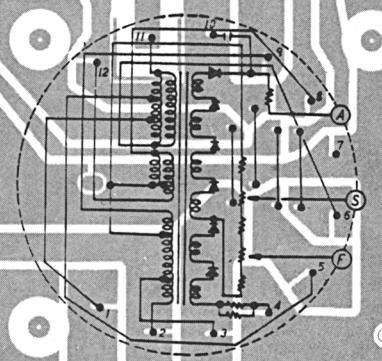

FB401
3714004
MM0002E

Ersatzteilliste für CTM 640 Farb-Monitor
Parts List for Model Type CTM 640 Colour Monitor

Widerstände/Resistors

Best.-Nr. Part No.	Bezeichnung	Description	Teile-Nr. Part No.	Zeich.-Pos. Ref.-No.
	RC ERD-25TJ331T	330	R011T4331J	R401
	RC ERD-25TJ182T	1.8 K	R011T4182J	R402
	RC ERD-25TJ182T	1.8 K	R011T4182J	R403
	RC ERD-25TJ331T	330	R011T4331J	R404
2658900-321	R, Metal, Oxide ERG-2ANJ682H	6.8 K 2W	R3118A682J	R405 △
	RC ERD-25TJ822T	8.2 K	R011T4822J	R406
	RC ERD-25TJ221T	220	R011T4221J	R407
	RC ERD-25TJ184T	180 K	R011T4184J	R408
	RC ERD-25TJ123T	12 K	R011T4123J	R409
	RC ERD-25TJ222T	2.2 K	R011T4222J	R410
	RC ERD-25TJ102T	1 K	R011T4102J	R411
	RC ERD-25TJ473T	47 K	R011T4473J	R412
	RC ERD-25TJ224T	220 K	R011T4224J	R413
	RC ERD-25TJ391T	390	R011T4391J	R414
	RC ERD-25TJ682T	6.8 K	R011T4682J	R415
	RC ERD-25TJ221T	220	R011T4221J	R416
	RC ERD-25TJ563T	56 K	R011T4563J	R417
	RC ERD-25TJ822T	8.2 K	R011T4822J	R418
	RC ERD-25TJ822T	8.2 K	R011T4822J	R419
	RC ERD-25TJ152T	1.5 K	R011T4152J	R420
	RC ERD-25TJ152T	1.5 K	R011T4152J	R421
	RC ERD-25TJ331T	330	R011T4331J	R422
	RC ERD-25TJ102T	1 K	R011T4102J	R423
	RC ERD-25TJ103T	10 K	R011T4103J	R424
	RC ERD-25TJ273T	27 K	R011T4273J	R425
	RC ERD-25TJ472T	4.7 K	R011T4472J	R426
2659000-321	R, Metal Oxide ERG-2ANJ332	3.3 K 2W	R3110A332J	R427 △
	RC ERD-25TJ103T	10 K	R011T4103J	R428
	RC ERD-25TJ103T	10 K	R011T4103J	R429
	RC ERD-25TJ823T	82 K	R011T4823J	R430
	RC ERD-25TJ153T	15 K	R011T4153J	R431
	RC ERD-25TJ102T	1 K	R011T4102J	R432
2659100-321	R, Metal Oxide ERG-2ANJ101	100 2W	R3110A101J	R433 △
2659200-3217	R, Fuse ERQ-1AJ2R2S	2.2 1 W	R615812R2J	R435 △
2659300-3219	R, Cement ERF-7ZYJ150	15 7W	R512CE150J	R436
2659400-3217	R, Fuse ERQ-1AJ2R2S	2.2 1 W	R615812R2J	R437 △
	R, Fuse ERQ-1CKPR82S	0.82 1 W	R61481R82K	R438
	RC ERD-25TJ823T	82 K	R011T4823J	R439
	RC ERD-25TJ393T	39 K	R011T4393J	R440
	RC ERD-25TJ152T	1.5 K	R011T4152J	R441
	RC ERD-25TJ182T	1.8 K	R011T4182J	R442
	RC ERD-50TJ1R2T	1.2 1/2 W	R011T21R2J	R443
2659500-3217	R, Fuse ERQ-14AJ8R2P	8.2	R615848R2J	R444 △
	RC ERD-50TJ471T	470 1/2 W	R011T2471J	R445
	RC ERD-50TJ222T	2.2 K 1/2 W	R011T2222J	R446
	RC ERD-50TJ681T	680 1/2 W	R011T2681J	R447
	RC NAS 1/2 W-152JPS	1.5 K 1/2 W	R0D102152J	R448
2659600-321	R, Metal Oxide M0R-1 W121J	120 1 W	R3D301121J	R449
	RC ERD-25TJ153T	15 K	R011T4153J	R450
	RC NAS-684JPS	680 K	R0D104684J	R451
2659700-3219	R, Cement ERF-5ZXK5R6	5.6 5 W	R512AD5R6J	R501 △
2659800-321	R, Metal Oxide ERX-3ANJ010H	1 3 W	R3118B010J	R502
2659900-321	R, Metal Oxide ERG-1ANJ102H	1 K 1 W	R31181102J	R503
	RC ERD-25TJ274T	270 K	R011T4274J	R504
2660000-321	R, Metal Oxide ERG-1ANH392H	3.9 K 1 W	R31181392J	R505
	RC ERD-50TJ184T	180 K 1/2 W	R011T2184J	R506
	RC ERD-50TJ184T	180 K 1/2 W	R011T2184J	R507
	RC ERD-25TJ471T	470	R011T4471J	R508
	R, Metal Oxide ERG-2ANJ330H	33 2 W	R3118A330J	R509
	RC ERD-25TJ471T	470	R011T4471J	R510
2660100-3217	R, Fuse ERQ-14AJ100P	10	R61584100J	R511 △
2660200-321	R, Metal Oxide ERG-2ANJ150H	15 2 W	R3118A150J	R512
2660300-321	R, Metal Oxide EERX-2ANJR22H	0.22 2 W	R3118AR22J	R513
	RC ERD-50TJ102T	1 K 1/2 W	R011T2102J	R514
	RC ERD-50TJ102T	1 K 1/2 W	R011T2102J	R515
	RC ERD-50TJ102T	1 K 1/2 W	R011T2102J	R516
	RC ERD-50TJ102T	1 K 1/2 W	R011T2102J	R517
	RC ERD-25TJ472T	4.7 K	R011T4472J	R518
	RC ERD-25TJ102T	1 K	R011T4102J	R519
2660400-321	R, Metal Oxide ERG-2ANJ820H	82 2 W	R3118A820J	R520
2660500-3217	R, Fuse RF25SJ 010	1	R63504010J	R521 △
	RC ERD-50TJ105T	1 M 1/2 W	R011T2105J	R801
	RC ERD-50TJ272T	2.7 K 1/2 W	R011T2272J	R802
	RC ERD-50TJ272T	2.7 K 1/2 W	R011T2272J	R803
	RC ERD-50TJ272T	2.7 K 1/2 W	R011T2272J	R804

Ersatzteilliste für CTM 640 Farb-Monitor
 Parts List for Model Type CTM 640 Color-Monitor

Widerstände/Resistors

Best.-Nr. Part.-No.	Bezeichnung	Description	Teile-Nr. Part.-No.	Zeich.-Pos. Ref.-No.
2660600-321	R, Metal Oxide ERG-1ANJ153	15K 1W	R31101153J	R805 Δ
	RC NAS 1/4W-271JPS	270	R0D104271J	R807 Δ
2660700-321	R, Metal Oxide ERG-1ANJ153	15K 1W	R31101153J	R808 Δ
	RC ERD-25TJ101T	100	R011T4101J	R810
	RC ERD-25TJ271T	270	R011T4271J	R811
2660800-321	R, Metal Oxide ERG-1ANJ153	15K 1W	R31101153J	R812 Δ
	RC ERD-25TJ271T	270	R011T4271J	R814
	RC ERD-25TJ102T	1K	R011T4102J	R815
	RC ERD-25TJ102T	1K	R011T4102J	R816
	RC ERD-25TJ101T	100	R011T4101J	R901
	RC ERD-25TJ101T	100	R011T4101J	R902
	RC ERD-25TJ101T	100	R011T4101J	R903
	RC ERD-25TJ272T	2.7K	R011T4272J	R904
	RC ERD-25TJ272T	2.7K	R011T4272J	R905
	RC ERD-25TJ272T	2.7K	R011T4272J	R906

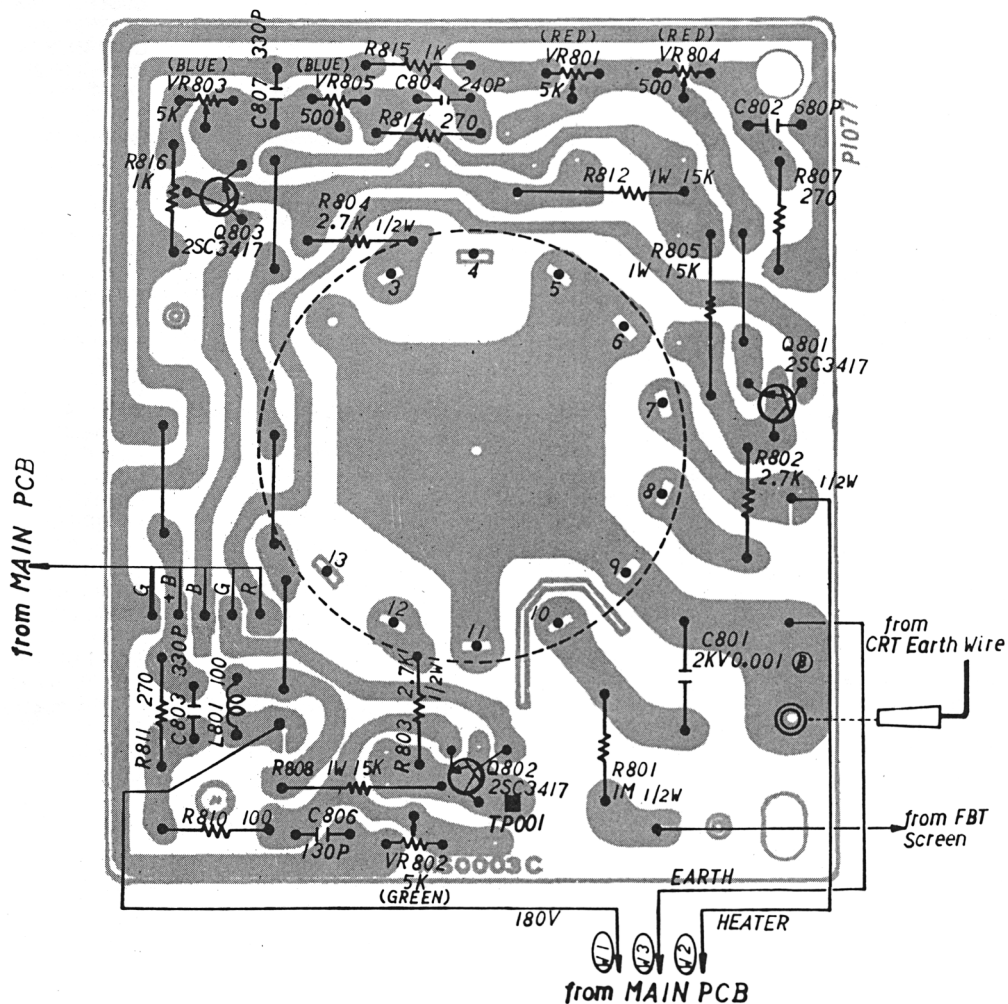

Ersatzteilliste für CTM 640 Farb-Monitor
 Parts List for Model Type CTM 640 Colour Monitor

Kondensatoren/ Capacitors

Best.-Nr. Part No.	Bezeichnung	Description	Teile-Nr. Part No.	Zeich.-Pos. Ref.-No.
	CE 160TWS470M	47 μ F 160V	E0250B470M	C401
	CE 35TWMS471M	470 μ F 35V	E0B104471M	C402
	CC HM60SJYB181K	180 μ F 500V B	C020B0562K	C403
	CP 50F2S393K	0.039 μ F 50V	P121T0393K	C404
	CE 16TWMS470MTA	47 μ F 16V	E021T2470M	C405
	CP CQ92MC1H473K	0.047 μ F 50V	P1D100473K	C406
	CE 50TWMS4R7M	4.7 μ F 50V	E0B1054R7M	C407
	CP 50F2S152K	0.0015 μ F 50V	P121T0152K	C408
	CP 50F2S153K	0.015 μ F 50V	P121T0153K	C409
	CP 50F2S683K	0.068 μ F 50V	P121T0683K	C410
	CTANTAL DA1C010M	1 μ F 16V	E252T2010M	C411
	CE 16TWMS101MTA	100 μ F 16V	E021T2101M	C412
	CP 50F2S103K	0.01 μ F 50V	P121T0103K	C413
	CE 50TWMS010M	1 μ F 50V	E0B105010M	C414
	CPL DSR-562J-50V	0.0056 μ F 50V	P541F0562J	C415
	CC HM60SJSL220K	22 PF 500V SL	C02FSL5H1K	C416
	CC HM60TJYB561K	560 PF 500V B	C02FB05S2K	C417
	CE 16TWMS470MTA	47 μ F 16V	E021T2470M	C418
	CE 160TWS010M	1 μ F 160V	E025TB010M	C419
	CE 50TWMS4R7M	4.7 μ F 50V	E0B1054R7M	C420
	CP 50F2S472K	0.0047 μ F 50V	P121T0472K	C421
	CP 50F2S683K	0.068 μ F 50V	P121T0683K	C422
	CC HM60SJSL101K	100 PF 500V SL	C02FSL512K	C423
	CE 25TWMS102M	1000 μ F 25V	E0B103102M	C424
	CE 35TWSS101MTA	100 μ F 35V	E027T4101M	C425
	CTANTAL DN1C2R2KIS	2.2 μ F 16V	E251T22R2K	C426
	CP 50F2S103K	0.01 μ F 50V	P121T0103K	C427
	CP 50F2S683K	0.068 μ F 50V	P121T0683K	C428
	CMPP DHS-824J-200V	0.82 μ F 200V	P441F2824J	C429
	CE 250TWS220MKC	22 μ F 250V	E0B5FD220M	C430
	CMPP DKR-123J-1600V	0.012 μ F 1600V	P442F9123J	C431
	CC D3070BN271K2KV	270 PF 2KV	C030BN7K2K	C432
	CC HM95SJSL271K	270 PF 500V SL	C02FSL5K2K	C433
	CC HM60TJYB271K	270 PF 500V B	C02FB05K2K	C434
	CE 25TWMS471M	470 μ F 25V	E0B103471M	C435
	CE 10TWMS470M	47 μ F 10V	E0B101470M	C436
	CE 10TWMS220MTA	22 μ F 10V	E021T1220M	C437
	CMPP LHP-104M-250V	0.1 μ F 250V	P445FB104M	C501
2664600-314	CC HS15SJYB222K	0.0022 μ F 2KV B	C020B07H3K	C502
2664600-314	CC HS15SJYB222K	0.0022 μ F 2KV B	C020B07H3K	C503
2664600-314	CC HS15SJYB222K	0.0022 μ F 2KV B	C020B07H3K	C504
	CE LPS4D101MHSC	100 μ F 400V	E03C0H101M	C505
	CE 250TWS010M	1 μ F 250V	E0250D010M	C506
	CE 35TWSS221M	220 μ F 35V	E02704221M	C507
	CC RTHE50SJYF472Z	0.0047 μ F F	C02TF04Q3Z	C508
	CC RTHE12SJYF472Z	0.0047 μ F	C02TF04QFZ	C509
2664700-314	CC DE1410BN152K2KV	0.0015 μ F 2KV	C030BN7E3K	C510
2664800-314	CC DE1210BN102K2KV	0.001 μ F 2KV	C030BN713K	C511
	CE 50TWSS470M	47 μ F 50V	E0B705470M	C512
2664900-314	CC ECK-DGS222MD4	2200 PF 4KV	C010D0222M	C513
2664700-314	CC DE1410BN152K2KV	0.0015 μ F 2KV	C030BN7E3K	C414
	CE 160TWS101M	100 μ F 160V	E025FB101M	C515
	CC DD07-63B102K500	0.001 μ F 500V B	C03FB0513K	C516
	CE 10TWSS471M	470 μ F 10V	E02701471M	C518
	CE 25TWMS471M	470 μ F 25V	E0B103471M	C519
	CE 16TWMS100MTA	10 μ F 16V	E021T2100M	C520
2665000-314	CC HS11SJYB102K	0.001 μ F 2KV B	C020FB731K	C801
	CC HE40TJYB681K	680 PF B	C02FB04U2K	C802
	CC HE40TJYB331K	330 PF B	C02FB04L2K	C803
	CC HE70SJSL241K	240 PF SL	C02FSL412K	C804
	CC HE60TJSL131K	130 PF 50V SL	C02FSL4C2K	C806
	CC HE40TJYB331K	330 PF B	C02FB04L2K	C807

Ersatzteilliste für CTM 640 Farb Monitor
Parts List for Model Type CTM 640 Color Monitor

Best.-Nr. Part No.	Bezeichnung	Description	Teile-Nr. Part No.	Zeich.-Pos. Ref.-No.
Halbleiter / Semiconductors				
2660900-302	JC	LA7800	I30D0D7800	IC401
2661000-302	JC	μPC1378H	I02SD13780	IC402
2661100-302	JC	STK-7308	I03S073080	IC501
2661200-302	JC	L78MG	I03A978MG0	IC502
2173600-301	Trans	KTC1815Y	TAA0018154	Q401
2173600-301	Trans	KTC1815Y	TCA0018154	Q402
2661300-301	Trans	KTA950Y	TAA009504	Q403
2661400-301	Trans	2SC2271	TC30022710	Q404
2661500-301	Trans	2SD1397	TD30013970	Q405
2661600-301	Trans	2SD1207	TD30012070	Q501
1283900-301	Trans	2SD880Y	TD50008804	Q502
2174200-301	Trans	KTA1015Y	TAA0010154	Q503
2173600-301	Trans	KTC1815Y	TCA0018154	Q504
2174200-301	Trans	KTA1015Y	TCA0010154	Q505
2173600-301	Trans	KTC1815Y	TCA0018154	Q506
2661700-301	Trans	2SC3417	TCA0018154	Q801
2661700-301	Trans	2SC3417	TCA0018154	Q802
2661700-301	Trans	2SC3417	TCA0018154	Q803
0807900-3041	Diode	1S2472T-77	D17T024720	D401
2661800-3044	Zenerdiode	RD11EB 2	D9200110B2	D402
2661800-3044	Zenerdiode	RD11EB 2	D9200110B2	D403
2661900-3041	Diode	RGP-10K	D2LFRGP10K	D404
2662000-3041	Diode	TVR06K	D2LFTVR06K	D405
2662100-3041	Diode	BB-4	D28000BB40	D406
2662000-3041	Diode	TVR06K	D2LFTVR06K	D407
2662000-3041	Diode	TVR06K	D2LFTVR06K	D408
2310900-3041	Diode	1N4007-EHC	D2LTN40070	D501
2310900-3041	Diode	1N4007-EHC	D2LTN40070	D502
2310900-3041	Diode	1N4007-EHC	D2LTN40070	D503
2310900-3041	Diode	1N4007-EHC	D2LTN40070	D504
2662200-3044	Zenerdiode	RD3.6FB	D92F13R6B0	D505
2662300-3041	Diode	RGB-10K	D2LFRGP10K	D506
2662400-3044	Zenerdiode	RD3.6FB	D92F13R6B0	D507
2662500-3041	Diode	RGP-10K	D2LFRGP10K	D508
2662600-3041	Diode	RGP-30J	D2L0RGP30J	D509
2662700-3041	Diode	SR-2M	D2BF00SR2M	D510
2662800-3041	Diode	RGP-30G	D2L0RGP30G	D511
2135000-3044	Zenerdiode	GZA6.2Y	D93006R20Y	D901
2135000-3044	Zenerdiode	GZA6.2Y	D93006R20Y	D902
2135000-3044	Zenerdiode	GZA6.2Y	D93006R20Y	D903
Spulen und Trafos / Coils and Transformers				
2662900-3253	Spule	21000002 1431MS	0221000002	L401
2663000-3253	Spule	FK0B160MH14	029A000002	L501
2663100-3253	Spule	8D140005	028D140005	L502
2663200-3253	Spule	RC875-473J-75 47μH	0218654701	L503
2663300-3251	Spule	EL0606SKI-101K 100μH	021663101K	L801
2663400-3243	Trafo Hor.	305Y001	03305Y0018	T401
2663500-3244	Trafo	53250011 1432MS	0453250011	T402
2663600-3243	Netztrafo	8142004	048142004G	T501
Buchsen und Stecker / Jacks and Connectors				
2663700-3328	Socket/Bildröhre	HPS-0079-01-010	0662130001	J801
Schalter / Switches				
2663800-3274	Schiebeschalter	SS-009-7H	0510422001	SW401
2663900-3272	Netzschalter	ESB-90197SK	0530103001	SW501

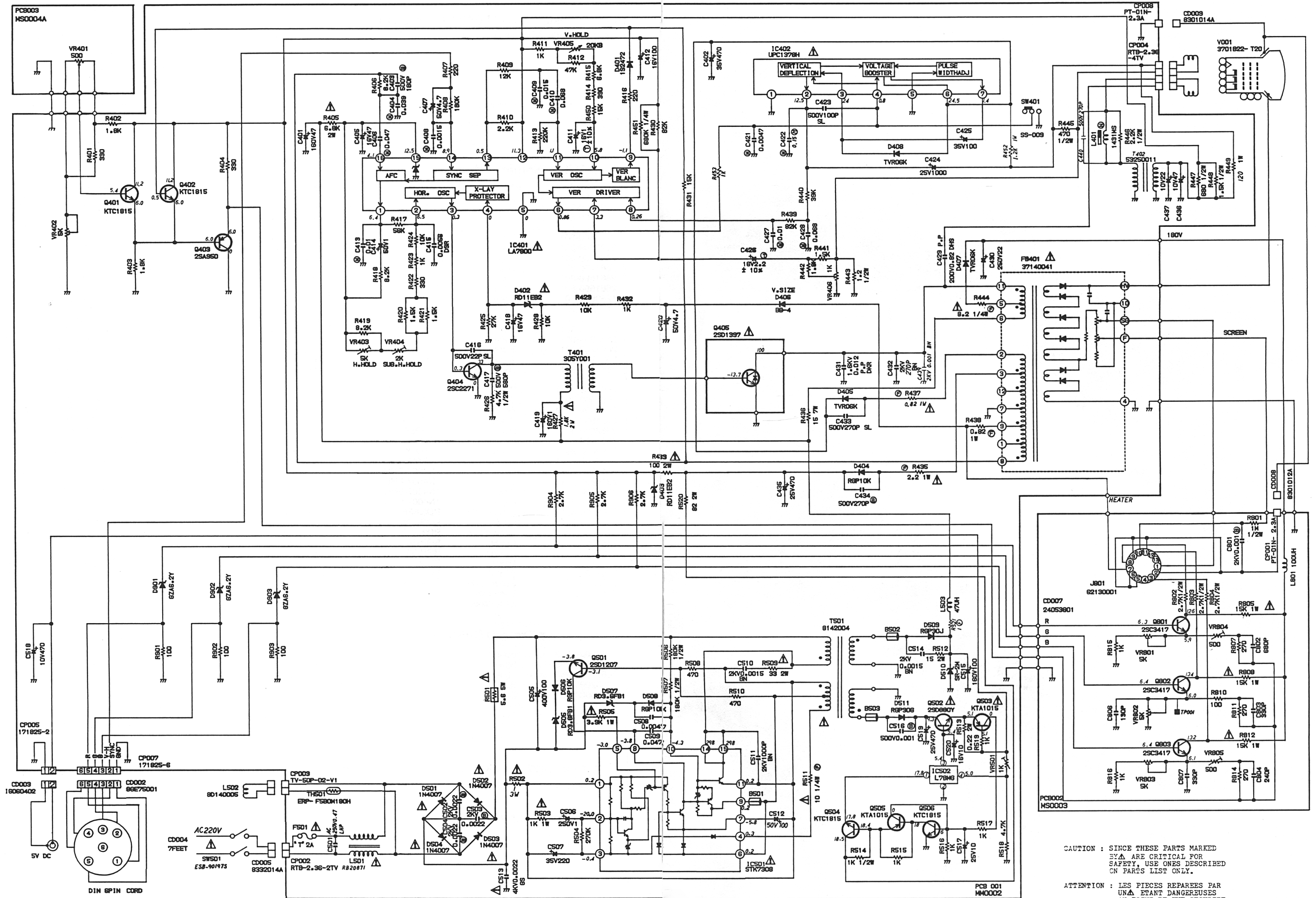

CAUTION : SINCE THESE PARTS MARKED
 BY A Δ ARE CRITICAL FOR
 SAFETY, USE ONES DESCRIBED
 ON PARTS LIST ONLY.

ATTENTION : LES PIÈCES REPARÉES PAR
 UN Δ ÉTANT DANGEREUSES
 AU POINT DE VUE SÉCURITÉ,
 N'UTILISER QUE CELLES DÉCRITES
 DANS LA NOMENCLATURE DES PIÈCES.

Ersatzteilliste für CTM 640 Farb-Monitor
Parts List for Model Type CTM 640 Colour Monitor

Best.-Nr. Part No.	Bezeichnung	Description	Teile-Nr. Part No.	Zeich.-Pos. Ref.-No.	
Potentiometer / Semi-Fixed Resistor					
2664000-3221	Drehregler	EVJEDAF25B52 EVN-K4AA00B53 EVL-V0AA00B53	V013052B01 V115353B01 V114053B01	VR401 VR402 VR403	
2664100	Drehregler	EVN-K4AA00B23 EWH-N0AS20B24 EVN-K4AA00B13 EVN-K4AA00B13 RVA0911H304-1-502M RVA0911H304-2-502M RVA0911H304-3-502M RVA0911H304-1-501M RVA0911H304-3-501M	V115323B01 V011024B01 V115313B01 V115313B01 V115313B01 V175C53B01 V175C53B02 V175C53B03 V175C52B01 V175C52B03	VR404 VR405 VR406 VR501 VR801 VR802 VR803 VR804 VR805	
Platinen / P.C. Boards					
2664200-502	Platine CTM 640	MM0002A	13MM0002A2	PCB001	
2664300-502	Platine CTM 640	MS0003B	13MS0003B2	PCB002	
2664400-502	Platine CTM 640	MS0004A	13MS0004A2	PCB003	
Verschiedenes / Miscellaneous					
		BL02R2-R62 BL02R2-R62 BL02R2-R62 8301004A G-511 8GE75001 1G060402 B2N 7FEET HANAI 8332014A	Cord, Beads Cord, Beads Cord, Beads Cord, Connector Cord, DIN Cord, DC Cord, AC Cord, Connector	024A8407C2 024A8407C2 024A8407C2 068301004A 068GE75001 121G060402 120L230005 068332014A	B501 B502 B503 CD001 CD002 CD003 CD004 CD005
		24053801 8301012A 8301014A RT-01N-2.3A RTB-2.36-2TV TV-50P-02-V1 RTB-2.36-4TV 171825-2 171825-6 RT-01N-2.3A 3714004 7800-6268 7800-6268 FST 2A (T) 250V HPS0079-06-010 1S313B B-17 ERP-F5B0M180H 1-2.5-15.5	Cord, Jumper Cord, Connector Cord, Connector Connector, PIN Center Connector, PCB Side Connector, PCB Side Connector, PCB Side Connector, PCB Side Connector, PCB Side Connector, Pin Center Trans., Flyback Holder, Fuse Holder, Fuse Fuse Socket, Cover, CRT Mica Sheet Mica Sheet Element, Degaussing Terminal, PIN	1224053801 068301012A 068301014A 0693010010 0693320018 0693320029 0693340018 0694120019 0694160019 0693010010 0437140041 067H000001 067H000001 0802T02001 0662330001 128F000001 1282100001 D810M180H0 126X000002 092F140403	CD007 CD008 CD009 CP001 CP002 CP003 CP004 CP005 CP007 CP008 FB401 FH501 FH502 FH502 JC801 MS401 MS402 TH501 TP001 V001
2664500-3244	Trafo Zeilen	3714004 7800-6268 7800-6268 FST 2A (T) 250V HPS0079-06-010 1S313B B-17 ERP-F5B0M180H 1-2.5-15.5	Trans., Flyback Holder, Fuse Holder, Fuse Fuse Socket, Cover, CRT Mica Sheet Mica Sheet Element, Degaussing Terminal, PIN	0437140041 067H000001 067H000001 0802T02001 0662330001 128F000001 1282100001 D810M180H0 126X000002 092F140403	FB401 FH501 FH502 FH502 JC801 MS401 MS402 TH501 TP001 V001
2664500-360	Farbbildröhre	3701B22-TC20	Tube, Cathode ray	V001	

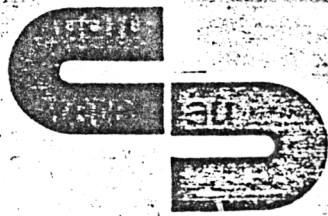

Schneider Rundfunkwerke GmbH & Co Türkheim/Unterallgäu

Schneider Rundfunkwerke GmbH & Co · D-8939 Türkheim 1

Silvastraße 1
Postfach 120

Fernruf (08245) 51-0
Fernschreiber 0539 128

ERSATZTEILLISTE

GÜLTIG AB 31.10.84

1693900-92220 COMPUTER COLOR MONITOR CTM 640

BLATT 1

BEST-NUMMER	ARTIKELBEZEICHNUNG			ZEICH PREIS	
				POS.	O.MST
2658500-431	GEHAEUSE	CTM 640	702KPA0025	120	26,60
2657800-431	FRONTRAHMEN	CTM 640	701KPB0003	101	45,00
2658200-4294	RAHMEN PLATINE	CTM 640	761KSA0047	106	0,70
2658000-4294	HALTER PLATINE	CTM 640	769JPA0001	103	1,00
2658400-438	HANDGRIFF	CTM 640	705KPA0001	119	2,15
2658300-4139	HALTER GRIFF	CTM 640	769JPA0004	118	0,35
2657900-4281	KNOPF DREH	CTM 640	732JPA0033	102	0,40
2658100-4282	KNOPF TASTE	CTM 640	735JPA0096	105	0,50
2658900-319	METOX ERG 2ANJ682H		R3118A682J	R405	0,30
2659000-321	METOX ERG2ANJ332		R3110A332J	T427	0,20
2659100-319	METOX ERG2ANJ101		R3110A101J	R433	0,20
2659200-3217	SICHERUNGS-WI	ERQ-1AJ2R2S	R615812R2J	R435	0,60
2659200-3217	SICHERUNGS-WI	ERQ-1AJ2R2S	R615812R2J	R437	0,60
2659300-3219	DRAHTWI ERF-7ZYJ150		R512CE150J	R436	1,60
2659500-3217	SICHERUNGS-WI	ERQ-14AJ8R2P	R615848R2J	R444	0,40
2659600-319	METOX MOR-1W121J		R30301121J	R449	0,15
2659700-3219	DRAHTWI ERF-5ZXX5R6		R512AD5R6J	R501	1,00
2659800-319	METOX ERX-3ANJ010H		R3118B010J	R502	0,60
2659900-319	METOX ERG-1ANJ102H		R31181102J	R503	0,20
2660000-319	METOX ERG-1ANH392H		R31181392J	R505	0,20
2660100-3217	SICHERUNGS-WI	ERQ-14AJ100P	R61584100J	R511	0,40
2660200-319	METOX ERG-2ANJ150H		R3118A150J	R512	0,30
2660300-319	METOX EERX-2ANJR22H		R3118AR22J	R513	0,30
2660400-319	METOX ERG-2ANJ820H		R3118A820J	R520	0,30
2660500-3217	SICHERUNGS-WI	RF25SJ010	R63504010J	R521	0,30
2660600-319	METOX ERG-1ANJ153		R31101153J	R805	0,20
2660600-319	METOX ERG-1ANJ153		R808,812		0,20
2664600-314	KERKO	0.0022 2KVB	C020B07H3K	C502	0,80
2664600-314	KERKO	0.0022 2KVB	C503,504		0,80
2664700-314	KERKO	0.0015 2KV	C030BN7E3K	C510	1,10
2664700-314	KERKO	0.0015 2KV		C414	1,10
2664800-314	KERKO	0.001 2KV	C030BN713K	C511	0,65
2664900-314	KERKO	2200 4KV	C010D0222M	C513	2,10
2665000-314	KERKO	0.001 2KVB	C020FB731K	C801	0,60
2660900-302	IC LA 7800		IC401		6,70

Banken · Banque

Dresdner Bank Augsburg, Konto 0106 609 200, BLZ 720 800 01
Postscheckamt München, Konto 202 03-809, BLZ 700 100 80

Sparkasse Mindelheim, Konto 3 004, BLZ 731 517 50

Hypobank Türkheim, Konto 2720107 508, BLZ 731 219 47

Alle Geschäfte unterliegen unseren Verkaufsbedingungen

All business transactions are subject to our terms of selling · Toutes les transactions se basent sur nos conditions de vente

Kommanditgesellschaft

Persönlich haftender Gesellschafter Schneider Elektronik GmbH,
Schneider Elektronik GmbH, Memmingen, BRD 89000

Geschäftsführer

Schneider Bernhard, Schneider Althart

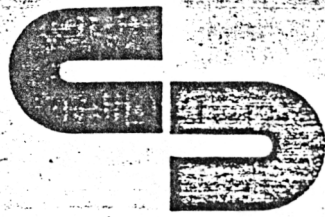

Schneider Rundfunkwerke
GmbH & Co
Türkheim/Unterallgäu

Schneider Rundfunkwerke GmbH & Co · D-8939 Türkheim 1

Silvastraße 1
Postfach 120

Fernruf (08245) 51-0
Fernschreiber 0539128

ERSATZTEILLISTE

GUELTIG AB 31.10.84

1693900-92220 COMPUTER COLOR MONITOR CTM 640

BLATT 2

BEST-NUMMER	ARTIKELBEZEICHNUNG		ZEICH PREIS	
			POS.	0.MST
2661000-302	IC UPC 1378 H	IC402		5,30
2661100-302	IC STK 7308	IC501		23,00
2661200-302	IC L 78 MG	IC502		3,10
2173600-301	TRANS KTC 1815 Y	Q401,402,5 04,		0,50
2173600-301	TRANS KTC 1815 Y	506		0,50
2661300-301	TRANS KTA 950 Y	Q403		0,60
2661400-301	TRANS 2 SC 2271	Q404		1,00
2661500-301	TRANS 2 SD 1397	Q405		6,50
2661600-301	TRANS 2 SD 1207	Q501		1,20
1283900-301	TRANS 2 SD 880 Y	Q502	TR 401	1,80
2174200-301	TRANS KTA 1015 Y	Q503,505	CV 50 RC	1,00
2661700-301	TRANS 2 SC 3417	Q801,802,8 03		1,60
0807900-304	DIODE 1 S 2472	D401		0,40
2661800-3044	ZENERDIODE RD 11 EB 2	D402,403		0,30
2661900-3041	DIODE RGP 10 K	D404,508		1,00
2662000-3041	DIODE TVR 06 K	D405,407,4 08		1,00
2662100-3041	DIODE BB 4	D406		0,80
2310900-3041	DIODE 1 N 4007	D501-504		0,20
2662200-3044	ZENERDIODE RD 3.6 FB	D505,507		0,70
2662300-3041	DIODE RGB 10 K	D506		1,00
2662600-3041	DIODE RGP 30 J	D509		2,80
2662700-3041	DIODE SR 2 M	D510		2,25
2662800-3041	DIODE RGP 30 G	D511		2,70
2135000-3044	ZENERDIODE GZA 6,2 X 00.Y	D901-903		0,70
2662900-3253	SPULE 1431MS	L401		4,10
2663000-3253	SPULE FK0B160MH14	L501		7,25
2663100-3253	SPULE 8D140005	L502		10,20
2663200-3253	SPULE RC875-473J-75	L503		0,80
2663300-3251	SPULE EL0606SKI-101K 100UH	L801		0,40
2663400-3243	TRAFO HORIZONTAL CTM 640	03305Y0018 T401		2,10
2663500-3244	TRAFO CTM 640	0453250011 T402		9,00
2663600-3243	NETZTRAFO CTM 640	048142004G T501		30,00
2664500-3244	TRAFO ZEILEN CTM 640	0437140041 FB401		60,00
2663700-3328	SOCKEL BILDROEHRE CTM 640	0662130001 J801		6,90
2663800-3274	SCHIEBESCHALTER SS-009-7H	0510422001 SW401		1,00

Banken · Banque Dresdner Bank Augsburg, Konto 0106609200, BLZ 72080001 · Sparkasse Mindelheim, Konto 3004, BLZ 73151750 · Hypobank Türkheim, Konto 2720107506, BLZ 73121947
Postscheckamt München, Konto 20203-809, BLZ 70010080

Alle Geschäfte unterliegen unseren Verkaufsbedingungen
All business transactions are subject to our terms of selling · Toutes les transactions se basent sur nos conditions de vente

Kommanditgesellschaft

Persönlich haftender Gesellschafter Schneider Elektronik GmbH,
Schneider Elektronik, Postfach 120, D-8939 Türkheim

Geschäftsführer
Schneider Bernhard, Schneider Albert

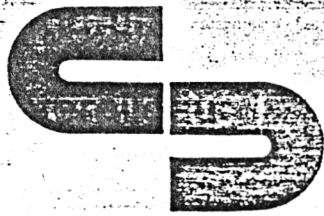

Schneider Rundfunkwerke
GmbH & Co
Türkheim/Unterallgäu

Schneider Rundfunkwerke GmbH & Co · D-8939 Türkheim 1

Silvastraße 1
Postfach 120

Fernruf (08245) 51-0
Fernschreiber 0539128

E R S A T Z T E I L L I S T E

GUELTIG AB 31.10.84

1693900-92220 COMPUTER COLOR MONITOR CTM 640

BLATT 3

BEST-NUMMER	ARTIKELBEZEICHNUNG			ZEICH PREIS	
				POS.	0.MST
2663900-3272	NETSCHALTER	CTM 640	0530103001 SW501	4,80	
2664000-3221	DREHREGLER	EVJEDAF25B52 CTM 640	V013052B01 VR401	1,35	
2664100-3221	DREHREGLER	EWB-NOAS20B24 CTM640	V011024B01 VR405	1,45	
2664200-502	PLATINE	CTM 640	13MM0002A2 001	339,00	
2664300-502	PLATINE	CTM 640	13MS0003B2 002	44,00	
2664400-502	PLATINE	CTM 640	13MS0004A2 003	2,10	
2915300-360	FARBILDROEHRE	CTM 640	092F140403 V001	366,00	
2658600-213	STYROPOR VORNE	CTM 640		3,60	
2658700-213	STYROPOR HINTEN	CTM 640		3,60	
2658800-212	FK	CTM 640		10,00	

PREISAENDERUNGEN VORBEHALTEN

Banken · Banque
Dresdner Bank Augsburg, Konto 0 108 609 200, BLZ 720 800 01 · Sparkasse Mindelheim, Konto 3 004, BLZ 731 517 50 · Hypobank Türkheim, Konto 2 720 107 506, BLZ 731 219 47
Postscheckamt München, Konto 202 03-809, BLZ 700 100 80

Alle Geschäfte unterliegen unseren Verkaufsbedingungen
All business transactions are subject to our terms of selling · Toutes les transactions se basent sur nos conditions de vente

Kommanditgesellschaft

Persönlich haftender Gesellschafter Schneider Elektronik GmbH,

Geschäftsführer
Schneider Bernhard, Schneider Albert