

# Home Computing WEEKLY

An Argus Specialist Publication

EVERY WEEK:  
The magazine  
with most software  
reviews

No. 41  
Dec 13-19, 1983

38p

**FREE**  
competition

£1,000-worth  
of new

**MOGUL**

software to be  
won

Software  
reviews for:  
Commodore 64,  
Spectrum, BBC,  
VIC-20, Texas,  
Oric, Dragon

ZX Microfair:  
first full report

Fun Spectrum  
games to play

Type in our  
VICpen program  
for great  
graphics

More  
programs to  
type in for:  
Texas, ZX81,  
Oric, Dragon,  
Atari

PLUS: news,  
U.S. Scene,  
letters,  
software charts



## Bible game out for Christmas

Just in time for Christmas, a clergyman has completed a Biblical adventure set in turbulent first-century Israel.

Jericho Road was written for the Spectrum by 44-year-old Peter Goodlad, pastor of Seven Kings United Free Church, near Ilford.

His Spectrum has been put to use both in church youth groups and during a Sunday service, running two of his earlier games.

One asks multiple choice questions about the parables and in the other, called The Lost Sheep, players have to round up the flock.

In Jericho Road, which costs £5.75 from Shards and runs on the 48K model, the player has to

*Continued on page 5*

## Decision soon on "ITV micro"

ITV companies were meeting this week to decide their future policy on computer programmes — and on proposals from some of the companies that independent ITV should produce its own rival to the BBC micro.

Reports had claimed ITV had called in micro builder Transam to produce a £400 computer with its own version of BASIC, the new Zilog Z80B processor, 64K or 256K of memory, and RS232

*Continued on page 5*

**NEW RELEASE**

**The Guardian**

£5-95

You are at the gateway to the Anti-Matter world of Magon... Do you dare enter?

SEND CHEQUE OR P.O. TO PLS 432 STOREY STANTON RD COVENTRY CV8 3DG FOR INSTANT CREDIT CARD SALES TEL 0203366754

# A sound choice for your Spectrum—

A crystal-clear sound module that simply plugs into the user port — only £30

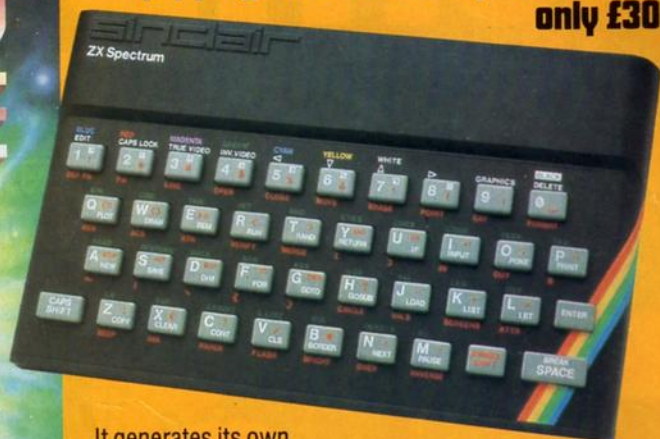
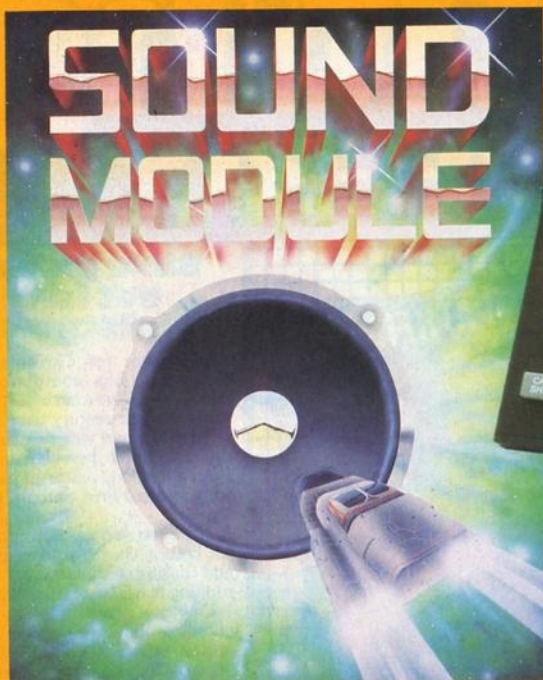

It generates its own sound through its own speaker, and unlike most other types, there is no need for additional programming. Make your game playing more exciting, more realistic, make your Spectrum sound output music to your ears. Also available for the BBC micro at £30.

**and a FREE choice of £30 software!**  
Buy the sound module and choose £30 of software free!



**Chuckman** Popular arcade game with extras. £5

**PLUS**

Leopard Lord £10  
Terror from the Deep £10  
Ace in the Hole £10



**3D Star Wars** Battle an entire rebel space fleet. £5

Horror Atoll £10  
Arcane Quest £10  
Cry Wolf £5  
Ziggurat of Dread £5  
Aliens £5



**The Roundsby Incident** What is Roundsby's secret? £10

One-Arm Bandit £5  
Eteor Torn £5  
'N' Vaders £5  
Terroroids £5  
Goblin Crusher £5

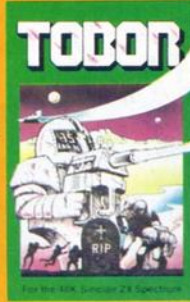

**Tobor** Fight robots through 6 levels. £5

Never Trust a Blonde £5  
Fisherman Fred\* £5  
ExT\* £5  
Penguin\* £5  
Seabattle\* £5



**Lost Over Bermuda** Will the Triangle claim you? £5

Cosmanoids\* £5  
Diamond Mine\* £5  
Golf\* £5  
Toolkit\* £5  
Grid Bug\* £5

\* 16K Spectrum — everything else 48K. All prices include p & p + VAT. UK only.

**ADD  
ON**  
ELECTRONICS  
Add-On Electronics Ltd.,  
Units 2, 3 and 4,  
Shire Hill Industrial Estate,  
Saffron Walden,  
Essex CB11 3AQ

To: Add-On Electronics Ltd., Units 2, 3 and 4, Shire Hill Industrial Estate, Saffron Walden, Essex CB11 3AQ  
Please rush me \_\_\_\_\_ Spectrum/BBC sound modules at £30 each.

I enclose cheque to the value to £ \_\_\_\_\_ or debit my Access  Barclaycard

No. \_\_\_\_\_

Name \_\_\_\_\_ Signature \_\_\_\_\_

Address \_\_\_\_\_

Postcode \_\_\_\_\_

I claim software cassettes to the value of £30 called:

\_\_\_\_\_

\_\_\_\_\_

\_\_\_\_\_

## 24 PAGES OF SPECTRUM BEST

Send 50p stamp to:  
Software Supermarket,  
87 Howard's Lane,  
London SW15 6NU

Tansoft has brought out its Oricmon machine code monitor, which includes an assembler and disassembler. Other features are printer and cassette handling; trace; slow motion run; and breakpoints. The package comes with a 50-page user guide.  
Price: £15

*Tansoft, Units 1 and 2, Techno Park, Newmarket Road, Cambridge*

Melbourne House has now taken over publishing rights to Abersoft Forth. Programs in Abersoft Forth are said to run 10-15 times faster than BASIC programs, without the need to learn machine code. Price: £14.95

*Melbourne House, 224 Stanley Road, Teddington, Middx. TW11 8UR*

Fidelity has moved into the home computer market with a 14 inch colour monitor which it says will work with virtually any computer or games machine. It will accept a range of inputs, including RGB, RGBY or composite video, plus audio, via a 21-pin scart-type socket. It costs £200.

*Fidelity, Victoria Road, London NW10 6ND*

Taxman from Mondatta isn't a business program — it's a game where you gather as much money as possible while avoiding the taxmen's clutches. Also out from Mondatta is Supercopter, which gives you a chance to save your country from destruction. Both games are for the Commodore 64 and cost £5.65.

*Mondatta, 38 Cuddington Ave, Worcester Park Surrey KT47DB*

From Pan, the people who brought you the 35mm Photographer's Handbook, comes The Personal Computer Handbook. Costing £5.95 in paperback and £9.95 hardback it has chapters on the elements of a microcomputer system, how your micro works, living with computers, the electronic home, the electronic office, and computers in the future. A glossary and buyer's guide (already slightly dated) is included.

*Pan Books, Cavaye Place, London SW10 9PG*

# Home Computing WEEKLY

News, U.S. Scene .....	5,6
Mogul Software £1,000 competition .....	7
Software reviews .....	10
Watery games for Commodore 64, Spectrum, Texas	
Dragon 32 program .....	13
Software reviews .....	15
Action games for Dragon, Spectrum, Texas, CBM 64	
VIC-20 program .....	17
Type in VICpen and draw in hi-res	
Software reviews .....	20
Cosmic games for BBC, Spectrum, CBM 64, Texas	
ZX8 program .....	23
Spectrum programs .....	25
Outlaws and Apeman — two great games to try	
Spectrum/ZX81 program .....	32
Software reviews .....	35
Games for Oric, BBC, Dragon, Spectrum	
Microfair report .....	36-37
Software charts .....	41
TI-99/4A program .....	44
Software reviews .....	49
Adventures for VIC-20, Spectrum, Texas	
One Man's View .....	50
Software reviews .....	53
Children's programs for BBC, Spectrum, Dragon	
Oric program .....	54
Make your micro quicker on the draw	
Letters .....	57
Atari program .....	58
A blockbuster of an adventure to type in	
<b>Don't miss next week's great Christmas issue — lots of great programs to type in.</b>	

Acting Editor: Paul Liptrot	Divisional Advertisement Manager: Coleen Pimm
Assistant Editor: Candice Goodwin	Assistant Advertisement Managers: Ricky Holloway Stuart Shield
Designer: Bryan Pitchford	Classified Advertising: Debra Stuppel
Managing Editor: Ron Harris	Chief Executive: Jim Connell

Argus Specialist Publications Ltd.

145 Charing Cross Road, London WC2H 0EE. 01-437 1002

Home Computing Weekly is published on Tuesdays. Distribution by Argus Press Sales and Distribution Ltd, 12-14 Paul Street, London EC2A 4JS. Printed by Alabaster Passmore & Sons Ltd, of London and Maidstone, Kent. Design and origination by MM Design and Print, 145 Charing Cross Rd., London WC2H 0EE

## BUY THIS SPACE

To advertise  
your latest products!  
Ring Coleen or Barry on  
01-437 1002 NOW!



You'll smile too when you play the three Spectrum games in this issue



Programs for children are reviewed on page 53



Let your Dragon work out your bills in advance — just type in the listing on page 13

**EARLY WARNING: We're moving. We move into our new offices on December 20. The address: No. 1 Golden Square, London W1R 3AB. Our phone number will then be: 01-437 0626.**



## Bible game

From front page

survive the rigours of Roman occupation and religious persecution in southern Israel.

He has a special mission on behalf of a persecuted minority and has a part in decoding an ancient puzzle.

Mr Goodlad said: "I'm a great believer in modern technology in the church, but it must be appropriate. The computer is a tremendous tool, but you've got to use it and not be dominated by it."

How had his congregation reacted? He said: "I think they are a bit bemused by it, but they have been very supportive. After all, I've found another way of expanding my ministry."



The Rev Peter Goodlad — believes in computers in the church

Mr Goodlad bought his Spectrum a year ago — with a lot of encouragement from his three daughters — and one of the first uses he found was for church records.

He said: "I started off thinking that was the way I was going to use it. But in order to be functional you've got to keep it up to date... and I got diverted to educational games. Maybe after Christmas I'll restore the records."

Daughters Alison, 17, Julie, 14, and 12-year-old Sally are delighted at their father's success.

Mr Goodlad said Alison had written some small programs and gave advice on Jericho Road.

But he said of his wife Jean: "She accepts it in the house but does not want to get involved — she's got enough to do."

Mr Goodlad plans to buy a full-sized printer with his royalties.

His future projects include a compendium of the best of the programs he has used in church work and further adventures based on the Bible.

He said: "There will be at least one sequel. I would love to create something out of the Book of Revelations. It has some incredible imagery and dramas."

Steve Maltz, of Shards, contacted Mr Goodlad after seeing him on TV.

He said: "He's the first real churchman to take a public interest in computers. I think it's a good thing — even if you don't look at the Christian side of it."

"He's taking history and turning it into an adventure with real people.

"We are planning a few more adventures you can believe in."

Mr Maltz said he and his wife Monica did not belong to any denomination, but thought of themselves as religious.

Shards Software, 189 Eton Road, Ilford, Essex IG1 2UQ

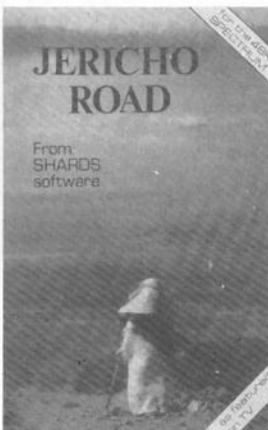

Jericho Road — set in turbulent times

## Briefly

For working BBC micros, Alligata has brought out three utility programs: Flexibase, Alligata-calc and Scribe II. They cost £9.95 each, and disc versions are available for Flexibase (£13.95) and Scribe II (£14.95).

Alligata, 178 West Street, Sheffield S1 4ET

New software house Solway has brought out two double-game tapes for the TI-99/4A — System Trader, at £5.55, and Cruiser (£4.55). Texas withdrew from home computers just two weeks before Solway was launched — too late to change course — so the firm is now thinking about writing for another computer too.

Solway Software, 6 Curzon Street, Maryport, Cumbria

Sunshine has brought out Graphic Art on the Commodore 64, which helps you to develop a high-res turtle graphics system. Written by Boris Allan, it costs £5.95.

Sunshine, 12-13 Little Newport Street, London WC2R 3LD

## ITV micro

From front page

and Centronics interfaces.

It would also have floppy and hard disc ports, a Prestel interface, and the ability to download telesoftware.

Commenting on the reports, David Shaw, of the Independent TV Companies Association, said: "The question of the involvement of ITV as a whole in computer programmes has been looked into. The crucial factor is what the IBA would think because the IBA has to approve any action of this kind."

"The IBA has now given its response, and its reply is due to be considered when we next meet."

"Supposing the response was that, that wouldn't be the whole story by any means. There are 15 companies in the association, and they've all got to agree."

"Certainly five or six companies are very much looking at the concept of producing ITV computer programs, and some people within certain companies have mooted the idea of an ITV

micro. But some other companies don't think it's appropriate. After all, we do have our advertisers to consider.

"The reports about an ITV micro have jumped the gun. They've given a fair description of some of the proposals we've received, but it's all speculation at this stage."

Tom Hohenberg, of Acorn, when asked what he thought about the rumours, said: "There won't be an ITV micro. It's highly unlikely that all the ITV companies would be able to agree on a specification and marketing strategy. But I expect that individual companies will be doing their own thing, bringing out computer programmes based around existing micros — maybe including the Electron!"

"It's a bit late to think about bringing out a new machine now. We've had enough production problems — we should know." He admitted, however, that "the bubble shows no sign of bursting, and sales of the BBC micro are booming."

All Transam had to say was: "We're not allowed to say anything about it."

## MICROSPHERE

MICROSPHERE COMPUTER SERVICES LTD  
72 ROSEBERY ROAD · LONDON N10 2LA  
TELEPHONE 01-883 9411

### EVOLUTION (48K Spectrum)

Can you trace the course of evolution from the primordial soup to man, keeping a balanced world and surviving the odd disaster as you go? Should be easy... after all it's been done before!

Only £6.95

### OMNICALC (48K Spectrum)

The best Spectrum spreadsheet you can buy. Written in machine code to be faster, to give you more space for data, and to allow more features to be included, it is guaranteed uncrashable.

"If more programs shared the quality of OMNICALC, then we might see more Spectrums in offices." Home Computing Weekly 3/5/83

"It is ideal for someone who has just found the spreadsheet concept, but it is also a very powerful tool for anyone who has used one previously."

Sinclair User June 1983

Complete with comprehensive manual £9.95

### ZX-SIDEPRINT (Spectrum & ZX81 versions)

Use ZX-Sideprint to print sideways, giving you 80/132 etc. characters per line. (State version reqd) £4.95

### CREVASSE & HOTFOOT (any Spectrum)

Can you make it across the ice-cap whilst chasms open and close all around? Or, help the rabbit get to fields full of carrots — but remember! the plumper the rabbit, the greater the danger.

2 original games for only £4.95

### NEW! THE TRAIN GAME (any Spectrum) NEW!

First there were model railways, then there were computers. Now Microsphere gives you both in one.

Featuring passenger, goods & express trains; tunnels; viaducts; points; stations; turntable bonus games; collisions; derailments; irate passengers; and everything else you expect from a major railway!

Two track layouts on each cassette. Superb value for money.

Only £5.95

## Fun in a bun

Ocean Software took over a software idea from the States for its beefy new game Mr Wimpy.

According to Ocean's MD David Ward: "In the States, all consumer items from MacDonalds to Kool-Aid and Coca-Cola have been put into a computer game. The manufacturers regard it as good promotion. But it's still a new idea here."

Ocean's game includes the Wimpy logo and advertising jingle. The player has to help Mr Wimpy make hamburgers, while fending off Waldo the burger thief and kitchen rebels Oggy Egg and Syd Sos with a pepper pot. It costs £5.90 for the 48K Spectrum.

David Ward said: "At first, we thought we were going to have to pay Wimpy a royalty for using the name. But when they saw the finished product, they liked it so much that they said we could use the name free, because it would be good advertising for them. And I think it will be, because the game is already selling fantastically well."

Wimpy even plans to sell the game in its hamburger shops over Christmas.

Now Ocean is following up Mr Wimpy with other games based on famous names.

It has just launched Royal

Birkdale, a golf simulation based on the well-known Southport golf course, which went down well with the club members themselves.

"They were there in their blazers with gold buttons, stabbing away at the Spectrum keyboard", David Ward recalled.

And Ocean is negotiating with two other well-known companies to launch programs along the same lines early in the new year.

*Ocean, Ralli Building, Stanley Street, Manchester M3 5FD*



Mr Wimpy — the hero of Ocean's new computer game

## Briefly

House of Death, a new game for the Oric, is a follow-up from Tansoft of its Zodiac adventure. A text adventure costing £9.99, House of Death takes place in a disused film set where a werewolf, Dracula, a witch and other unpleasant characters try to stop you leaving. Defence Force is a space shoot-'em-up game at £7.95. Both games are for the 48K Oric and are from Tansoft.

*Tansoft, Unit 1, Techno Park, 645 Newmarket Road, Cambridge CB5 8PB*

Five new games from Abacus: Proteus, Fireflash, Munnerys Mergatroids, Galactic Warriors and Super Digger. All the games cost £5.95 each, and each include a second BASIC game on the B side. Proteus and Fireflash are also sold along with Abacus's Sentinel and Avenger in a £14.95 gift pack.

*Abacus, 716 Llangyfelach Road, Treboeth, Swansea SA5 9EL*

Soft Shop is the name of yet another new chain of software shops, which will be springing up all over the Home Counties over the next few months. The first

shop opened in Chalfont St Peter last November. The idea is for the shops to stock a wide range of software and accessories for different machines. Trained staff will be in attendance, and customers will be encouraged to try programs out in the shop before they buy.

*Soft Shop, 10 Church Walk, Chertsey, Surrey*

Smiths will soon be stocking the AMS 3 inch disk drive for the BBC micro. The drive is available in a single 100K format at £225 or a 200K format at £399, and runs off the BBC power supply.

*AMS, Woodside Technology Centre, Green Lane, Appleton, Warrington, Lancs.*

Dynatech has launched Home Filewriter, a do-it-yourself database program, for the Commodore 64 or Atari plus discs. You can type in the screen layout you want using ordinary English commands which the computer translates into code. The program comes with a demonstration disc, and costs £39.95.

*Dynatech, Rue du Commerce, Bouet, St Peter Port, Guernsey, Channel Islands*

# Your micro can put on a slide show

*Here's some news about a novel and exciting program available for the VIC-20 and Commodore 64. It is called Color-Craft and can be used to allow the computer to put on a "slide show" or otherwise present variable-time screen displays of text and graphics.*

*Using the graphics keys, you design screen displays which are then stored. Prior to playback, you decide how long each screen will be displayed. This can create animation and/or cartoon-like effects.*

*The maximum number of pages available depend upon the obvious factors of screen detail and available memory. For example, a 16K VIC can store from 12 to 50 pages, each page being five characters by 10 lines, whereas a 64K 64 can store as many as 25 full screens (21 by 40). According to reports, the program is even more useful and educational than its advertisements would have you believe. This is a real treat compared to the usual situation.*

*It is easy enough for most children to use, and is flexible enough to allow real creativity. It is apparently well error-proofed, and supplied with very good documentation.*

*If you are into graphics and/or want to design your own custom screen displays without a lot of hassle this may be just the thing for you. The programs are bargain priced too. Cassette or disc versions are available. Prices: \$24.95 for VIC and 64 tape versions or \$29.95 for 64 disc. Further details are available from Sim Computer Products, P.O. Box 7, Miquon, PA 19452. (215) 825-4250.*



*Tandy has announced a printer for the Colour Computer. The unit is set to retail for \$99.95! It is called the TP-10, and is a thermal printer which prints a quiet 32 characters per line at 30 characters per second. Special thermal paper is of course required.*

*It will work with both the MC-10 Micro Colour Computer as well as the regular Colour Computer. Rolls of thermal paper, four and one half inches wide, are also available from Tandy and will cost about \$3.95 for a package of two rolls. The printer is capable of printing out 95 standard ASCII characters as well as 16 block-graphics characters. See your local dealer for more details. Sounds like a reasonable value.*



*This item is included more for its humor value than anything else. Several years ago a rush of articles appeared in all the electronics technical magazines which all said about the same thing.*

*They were devoted to instructing the clever DIY person as to how to wire their regular television set so that their computer could send it direct video.*

*The result of the modification was the installation of jack on the outside of the set coupled directly to the video amplifier.*

*This made superfluous the use of a modulator and did much to improve the quality of the computer display. Most of these articles appeared long before the advent of the low cost VDU.*

*Well, now a firm in San Jose has started to market a little device which they call a tuner adapter. It connects to any monochrome or color computer monitor and, guess what? turns it into a television set!*

*One of the selling points the firm uses is that for about one third the cost of a color set, buyers can have a spare television.*

*What is really amusing is that monitors themselves cost so much more than televisions and have so much less circuitry inside.*

*So now computer users can pay at least one third more for a monitor than a comparably sized television and then pay an addition third to turn their monitor back into a television.*

*This all makes perfectly good sense if you live out here where I do.*

*Out of room once again. See you next week.*

**Bud Izen**  
Fairfield, California

## COMPETITION

# Free: £1,000 worth of new

# MOGUL

## software must be won

JUST find the words and a share of £1,000-worth of software could be yours.

We have got together with Mogul, the new force in computer software, for this week's competition.

The 46 winners will receive a prize package of tapes worth about £22 for three of the most popular computers — the Spectrum, VIC-20 and Commodore 64.

Mogul Software, a division of video company Mogul Communications, made its debut in November with both U.S. best sellers and a range produced in Britain.

### How to enter

The word square below contains the names of a number of Mogul software titles. They are horizontal, vertical and diagonal.

All you have to do is mark them clearly in ballpoint pen, including your computer — so we know which prizes to send — and the number of titles you found.

All the titles in the square, plus several more, are in this list:

Metamorphosis	Tiny Compiler
Zeus	Kongo Kong
Creator's Revenge	Earthquake
Super Trek	Pyramid
The Great	Pollywog
Adventure Pack	Crash
Potty Planter	Annihilator
Las Vegas Lady	Maths Tutor

When you have completed the word square and the coupon, cut around the broken lines and enclose the attached two in an envelope addressed to Mogul Software Competition, Home Computing Weekly, No. 1 Golden Square, London W1R 3AB.

This is our new address from close of business on December 19.

**Important:** you must also write on the back of the envelope the number of software titles you found. Any without this will be discarded.

Entries close at first post on Friday December 30.

You may enter as many times as you wish, provided each is on the official word square and coupon, not copies, and in a separate envelope.

The winners will be the first 46 correct entries opened, regardless which of the three computers have been marked on the coupons.

The solution and the names of the winners will appear on the news pages of Home Computing Weekly and the prizes will arrive from Mogul within 28 days of that issue.

**Are you good with words? See how many Mogul titles you can find in our word square and you could be among our 46 winners of great new software**



### The rules

The first 46 correct entries drawn will win the prizes. Coupons which are not fully completed and envelopes without the number of differences found on the back will not be considered.

Entries close at first post on Friday, December 30, 1983.

Entries will not be accepted from employees of Argus Specialist Publications, Mogul and Alabaster Passmore & Sons. This restriction also applies to employees' families and agents of the companies.

The winners' names and the solution will appear in Home Computing Weekly. The editor's decision is final and no correspondence will be entered into.

### Mogul Software Competition Entry Coupon

Name \_\_\_\_\_

Address \_\_\_\_\_

\_\_\_\_\_

Post code \_\_\_\_\_

Computer \_\_\_\_\_

Number of differences found \_\_\_\_\_

Please complete carefully and post to Mogul Software Competition, No. 1 Golden Square, London W1R 3AB. Closing date: First post Friday December 30, 1983

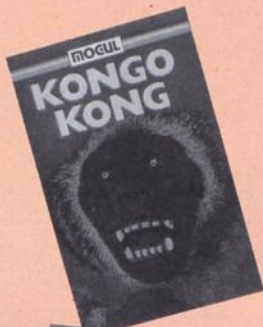

L	A	S	V	E	G	A	S	L	A	D	Y	Z	W	O	O	T	Y	I
A	C	V	E	R	Q	S	U	O	P	B	E	T	C	J	Q	R	T	Z
L	K	J	F	D	A	S	P	O	L	L	Y	W	O	G	G	H	J	M
T	C	R	E	Y	P	Q	E	M	B	D	K	M	H	G	F	D	S	M
U	P	B	M	E	V	O	R	A	V	O	P	T	E	D	J	B	I	C
I	D	G	J	E	A	R	T	H	Q	U	A	K	E	C	X	Z	G	H
O	B	E	V	C	G	E	R	T	N	A	D	F	Y	A	L	Q	T	Y
Q	I	M	U	R	H	W	E	W	Y	Z	S	V	B	N	H	I	J	
U	I	A	P	Q	S	T	K	E	X	P	B	O	G	P	Q	M	P	R
A	D	T	I	N	Y	C	O	M	P	I	L	E	R	K	L	N	S	T
R	C	H	U	I	O	L	Q	R	P	T	U	A	U	W	O	Y	Z	N
G	L	S	M	K	Y	K	O	N	G	O	K	O	N	G	B	O	C	I
J	R	T	V	Z	S	T	A	V	W	O	A	V	O	T	D	F	G	J
W	X	U	A	T	T	S	R	E	P	R	I	U	N	Z	E	U	S	K
A	C	T	Y	U	U	N	K	Q	S	X	S	T	M	L	E	R	P	M
N	Y	O	Z	B	B	W	E	Y	L	Z	F	G	U	T	H	V	U	W
P	Y	R	A	M	I	D	V	M	X	D	S	C	R	A	S	H	O	P
M	E	T	A	M	O	R	P	H	O	S	I	S	J	I	R	X	Z	A

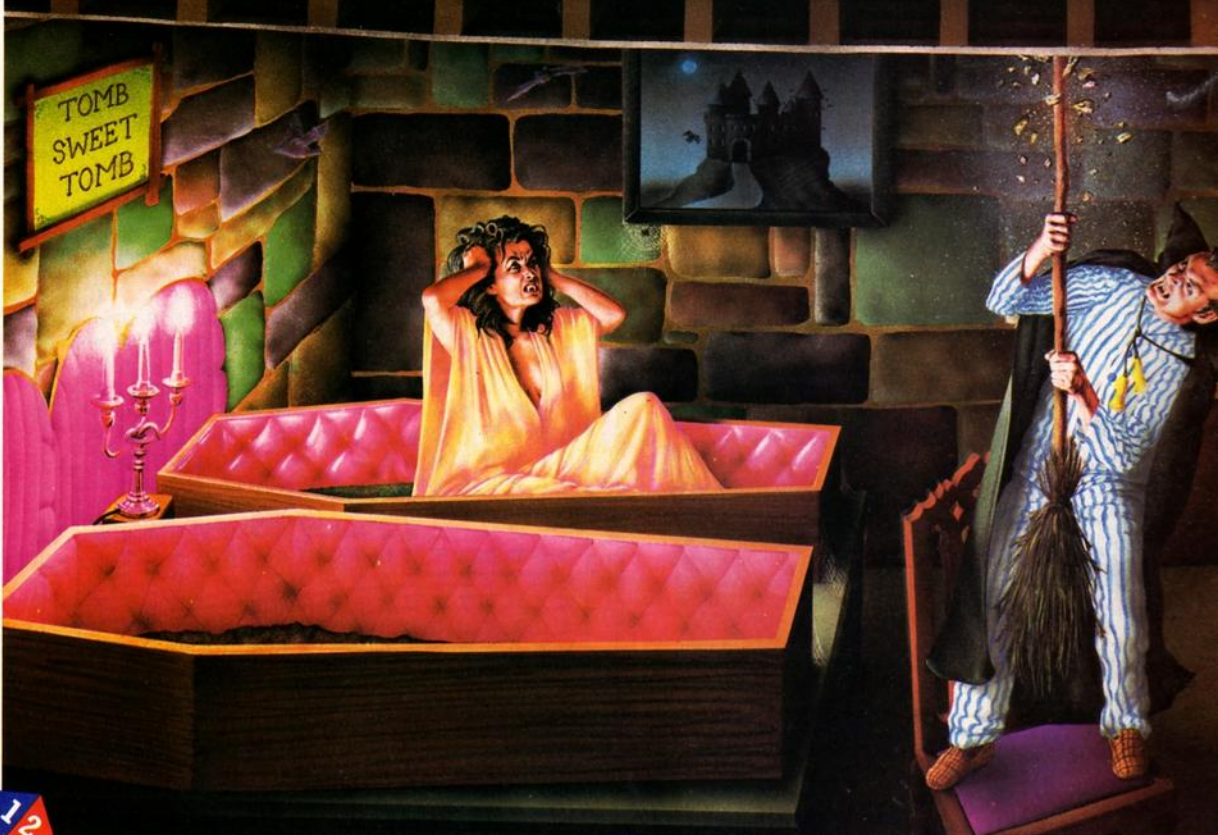





# Once you've got to grips with the Rock 'n' Roll game, flip-over and get your teeth into Dracula.

New K-tel Doublesiders are great fun and great value which ever way round you look at them.

For only £6.95 you don't just get one top quality computer game, you get two.

When you've finished playing one side simply flip it over (just like a music cassette) and move off on a second totally different, equally gripping game.

Take your choice. Already there are five Doublesiders to choose



- 1 **It's Only Rock 'n' Roll** Can you become a superstar? A Rock 'n' Roll idol...Or are you just another has been? You've got a lot of energy, a bit of money and a great future. But can you stay the course, stand the heartbreaking disappointments, fraud, scandal, even arrest? Can you capture the hearts and wallets of the public and become a Rock 'n' Roll idol?
- 2 **Tomb Of Dracula** Darkness is falling...The vampires are hungry...You can't go back...Your only chance of survival lies ahead. The walls are cold and clammy. With each step you remember the horrors ahead; ghouls, zombies and pits of choking slime. In your hand you have but seven silver stakes with which to defend yourself...Dare you face the ultimate evil...and win.

from — three suitable for the ZX Spectrum and two for the Commodore Vic 20 — and there are more to come.

So hurry to the shops now and see for yourself how K-tel Doublesiders really do give you twice the fun with two on one.

## K-TEL DOUBLESIDERS

Only £6.95 EACH



Twice the fun with two on one.

**Shark Attack**  
**Spectrum**  
**£5.99**

Romik, 272 Argyll Avenue, Slough, Berks

Just when you thought it was safe to go in the sea again, Romik introduces Shark Attack.

You must surround sharks with a continuous net, to prevent them eating you, or the octopuses. If a shark eats an octopus, it can eat the net and this creates a bit of bother.

Three skill levels are provided, and the cassette mentions that the game works with Kempston or Sinclair joysticks. Sinclair joysticks? Does Romik know something we don't know?

When the sharks finally finish you off, you are asked to enter your initials for the Hall of Fame; however, to do so, you are asked

to use the fire button. What fire button? Until this stage there is no mention of a fire button.

Is this a casualty of the Christmas rush, where subroutines are lifted wholesale from previous efforts and simply tacked on? Pretty poor and unprofessional if you ask me!

Despite the underwater setting, this game is too derivative to excite even the most unjaded of palates.

Try throwing yourself on the sharks for a change, the graphics and sound effects for a 'kill' are quite good!

M.B.

instructions	40%
playability	70%
graphics	70%
value for money	70%



**Hop It!**  
**Ti-99/4A**  
**(Extended BASIC) £6.95**

Lantern Software, 4 Haffenden Road, Tenterden TN30 6QD

Yet another game of Frogger, and

by far the poorest that I have seen, the more so since the use of Extended BASIC and sprites confers the potential for an excellent imitation.

What lets this program down very heavily is the appalling keyboard response, giving delays of up to a second.

The worst is when attempting to cross from a log to a turtle. The

**Messing about on the water**

**We look at a selection of games with watery themes**

delay here is inconsistent, which introduces an element of chance into a game which is otherwise dependent upon manual and intellectual skills.

Although the task of getting a frog across a road and a river to a pool, avoiding hazards on the way, is not timed, it is a good graphical imitation of the real thing.

There are turtles which submerge if you leave the frog on them for too long, so if you're not

a quick decision-maker you could take a long time to build up a score.

Land in a pool containing a fly, and you get bonus points, and when all the pools have frogs in them you get an extra frog and the game speeds up.

P.B.

instructions	65%
playability	35%
graphics	85%
value for money	60%



**River Rescue**  
**48K Spectrum**  
**£7**

Thorn-EMI, Upper St Martin's Lane, London WC2H 9ED

River Rescue is a kind of waterborne Scramble/Penetrator game.

You have a bird's eye view of a river and its banks which scroll across the screen. Your task is to pilot your motor gun-boat avoiding islands and crocodiles.

If you manage to shoot the crocs you gain points; if you hit them, you sink!

Every now and then you have the opportunity to collect explorers from the north bank and deliver them to the south, and gain more points.

The more explorers you collect, the more the program offers extra scoring facilities; get really good,

and two planes start to bomb you in addition!

The game is incredibly fast and furious, as there is no skill level adjustment, which I rate as a disadvantage.

There are other snags too; the boat tends to crash when it's near an obstacle rather than being in contact with it; the animation is rather crude and the sound dull and repetitive.

I suppose I expected a large company like Thorn-EMI to produce a program which was technically superior to those of the small software houses.

The question must be asked: are you paying an extra pound or so for a flash inlay card and large corporate overheads?

D.M.

instructions	100%
playability	60%
graphics	60%
value for money	60%



**Ship of the Line**  
**Commodore 64**  
**£6.50**

Richard Shepherd Software, 3-25 Elmshott Lane, Chippenham, Slough, Berks

Up to now Richard Shepherd has concentrated on the Spectrum, so this program represents an excursion into new fields.

Quite simply, you control a sailing ship and endeavour to gain promotion by sinking or capturing enemy ships. You set sail with a full complement of men, food and ammunition and search for the enemy.

One word commands such as go-on, attack, engage, port etc. to manipulate your ship. Enemy ships can be attacked but if you elect not to attack they will pursue you.

During an attack you can sink

or board the ship and gain points.

Throughout the voyage you are subjected to sundry mishaps such as mutinies, scurvy, bad food and yellow fever. This generally depletes your food, men or both.

It is wise to return to port occasionally to replenish your ship. If, on return to port, you have enough 'hero' points, you will be considered for promotion. Promotion will finally depend on a ridiculously banal test.

Overall, not a wonderful game. Graphics were mediocre and sound was appalling. The game didn't do justice to the power of the 64.

Basically a good idea which lacked imagination and thought.

A.W.

instructions	60%
playability	60%
graphics	50%
value for money	60%

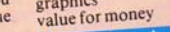

**Angler**  
**48K Spectrum**  
**£5.95**

Virgin Games, 61/63 Portobello Road, London W11

You have 100 casts to catch as many fish as possible. The fish move smoothly from side to side in 18 rows, and you can move your boat along the surface of the

sea.

It is very difficult to catch the fish, because it is hard to cast the line in the correct position.

To catch the fish in deeper waters, you must also make sure that the line doesn't hit any fish on its way down, otherwise the line reels back, so it's a wasted cast.

I found it practically impossible to catch the deeper fish, even on the easiest of the five skill levels.

If you catch a crab, you lose a point with each cast. However, the smaller version of the meanest-looking fish will eat all your crabs — if you manage to catch one!

Every go you must type in your name — it would be better if you only had to when you get a high score. You can make a printout of the Hall of Fame or Certificate of Merit — they are shown with each score.

It is so difficult to catch the fish

that you tend to lose interest quickly — a bit like real-life fishing.

S.E.

instructions	80%
playability	35%
graphics	60%
value for money	40%





# Stell Software

— — — for top quality programs

Make learning fun with these top quality educational games!

**Maths Invaders** - answer the questions correctly or the invaders will land on you. 4-12yrs. (Spectrum 16/48k, BBC B, Electron.)

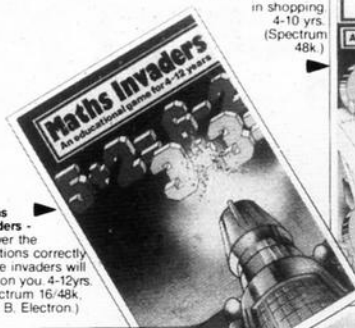

**Money** - an introduction to coins and notes and their use in shopping. 4-10 yrs. (Spectrum 48k.)



**Missing Words** - watch the train move forward when you type in the right word. 4-10 yrs. (Spectrum 48k.)



**Identikit** - choose from a range of features and build up a face on the screen. 2-8 yrs. (Spectrum 48k.)

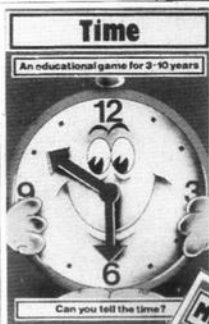

**Time** - learn to tell the time with this simple step by step guide. 3-10yrs. (Spectrum 48k, BBC B, Electron.)



**Micros for Children 1**, a set of four educational games for children of 3-8 yrs. Excellent value! (Spectrum 16/48k.)



**Railroader** - lay track on the screen in any layout you want. 4-10 yrs. (BBC B, Electron.)



Spectrum programs only **£6.95** BBC/Electron programs only **£7.95**  
 Ask for **Stell Software** at larger branches of **Boots, John Menzies, W. H. Smith**  
 and all good computer shops, where most titles are available.  
 Dealers should contact their regular distributors.

# No. 1 in Education

Stell Software 36 Limefield Ave, Whalley, Lancs, BB6 9RJ.

# AGF

## JOYSTICK INTERFACE II

for

# Spectrum

or ZX81

**NEW PRICE**

ONLY  
79.95  
+£10.00P  
**15.95**

### JOYSTICK INTERFACE

The Interface Module II has been specially designed to plug on to the rear connector of your ZX Spectrum or ZX81 and allow you to connect any standard Atari type digital Joysticks. All of the computer's connections are duplicated on an extension connector so that you can still use any other devices intended for use with your computer. The Interface Module II resides in the same memory space as the keyboard, which remains fully functional at all times, therefore it will not interfere with anything else connected.

When a suitable joystick is plugged into 'Player 1' socket its action will mimic pressing the cursor keys, up "7", left "5" and so on. The firing button will simulate key  $\phi$ . This unique feature guarantees the best software support.

Take a look at the selection of compatible games we have listed. More are being added all the time as a result of our contact with the various software companies.

A second Joystick may be connected in the 'Player 2' position which simulates in a parallel fashion keys T-Y-U-I-P. This will allow you to play a whole new generation of two player games.

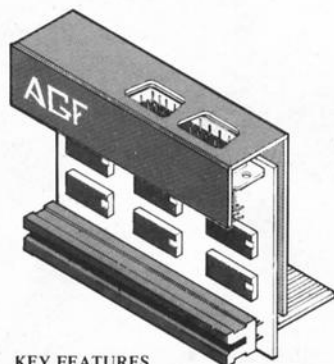

### KEY FEATURES

- \* Proven cursor key simulation for maximum software support
- \* Accepts Atari, Competition Pro, Wico, Starfighter, Le Stick, etc Joysticks
- \* Second Joystick facility
- \* Rear extension connector for all other add-ons

### AGF COMPATIBLE SOFTWARE - AVAILABLE NATIONWIDE

The following titles are available from us:

Galactic Jailbreak/	: Apocalypse	
Snake	: Software	£4.95
3D Tanx	: DK Tronics	£4.95
Splat!	: Incentive	
	: Software Ltd	£5.50
Phoenix	: Megadodo	
	: Software	£5.50
Escape	: New Generation	
	: Software	£4.95
3D Tunnel	: " "	£5.95
Knot in 3D	: " "	£5.95
Cyber Rats	: Silversoft	£5.95

### COMPATIBILITY CASSETTES £4.95

These cassettes have short programs to load before the chosen game which will convert it to use the cursor keys and therefore become compatible with the Interface Module II.

<b>Cassette 1 converts</b>	<b>Cassette 2 converts</b>
Arcadia	Centipede
Schizoids	Planetoids
Hungry Horace	Jet-Pac
Horace Goes Skiing	† Psst
Spectres	† 3D Combat Zone
Penetrator	† Invaders
	† Will require 48K Memory.

FROM: MR/MRS/MISS			
ADDRESS			
HCW41			
SEND C.W.O. (NO STAMP NEEDED) TO: A.G.F. HARDWARE, DEPT.			
FREEPOST, BOGNOR REGIS, WEST SUSSEX, PO22 9BR			
QTY	ITEM	ITEM PRICE	TOTAL
	INTERFACE MODULE II	16.95	
	JOYSTICK(S)	7.54	
	SOFTWARE:		
	SOFTWARE:		
ZX81 <input type="checkbox"/>	ZX SPECTRUM <input type="checkbox"/>	Please tick	
DEALER ENQUIRIES WELCOME		EXPORT PRICES ON APPLICATION	
<b>WHERE TO BUY AGF PRODUCTS OVER THE COUNTER</b>			
<p><b>Ashby Computer Centre</b> 186 Ashby High Street, Scunthorpe, S. Humberside DN16 2JR</p> <p><b>Brainwave Microcomputers</b> 24 Crown Street, Ipswich, Suffolk IP1 3LD</p> <p><b>Buffer Micro Ltd</b> 310 Streatam High Road, London SW16</p> <p><b>Chelsea Micros Ltd</b> 14 Jerdan Place, London SW6 1BH</p> <p><b>Computers of Wigmore Street</b> 87 Wigmore Street, London W1H 9FA</p> <p><b>Everybody's Hobbies</b> 1 Great Colman Street, Ipswich, Suffolk IP4 2AA</p>	<p><b>4Mat Computing</b> 67 Friargate, Preston, Lancashire PR1 2AT</p> <p><b>Gamer</b> 24 Gloucester Road, Brighton BN1 4AQ</p> <p><b>GB Microland</b> 7 Queens Parade, London Road, Waterlooville, Hants</p> <p><b>Melgray Hi-Tech Ltd</b> 49 Broad Street, Hereford HR4 9AR</p> <p><b>Micro Fare</b> 296 Gloucester Road, Horfield, Bristol</p> <p><b>Raven Video</b> 74 Green Lane, Tettenhall, Wolverhampton</p> <p><b>Screen Scene</b> 144 St George's Road, Cheltenham Gloucestershire GL50 3EL</p>	<p><b>Screens</b> 6 Main Avenue, Moor Park, Northwood Middlesex.</p> <p><b>Syntax Computers</b> 76 Cornwall Street, Plymouth PL1 1NS</p> <p><b>Teleco Video</b> 53 Maple Road, Penge, London SE20</p> <p><b>Telford Electronics &amp; Computing</b> 26a Bradford Street, Shipnal, Shropshire TF11 8AU</p> <p><b>The Computer Shop</b> Unit 25, Handyside Arcade, Percy Street, Newcastle-upon-Tyne NE1 4PZ</p> <p><b>The Computer Centre (Humberside) Ltd</b> 26 Anlaby Road, Hull HU1 2PA</p>	
		<b>FINAL TOTAL</b>	

# Here's how to ease the shock of those bills

Do you find your power bills difficult to believe? Now you can check them — and get the bad news earlier.

My program, for the Dragon 32, works out gas and electricity bills and all you have to do is to follow the prompts.

You will be presented with a menu of three choices: gas, electricity or end of program.

The first is quite straightforward but gas bill calculation is slightly more complex (and confusing) due to the illogical way in which these bills are calculated.

In the south east region, variable G will be .28p (standing charge per week), but other areas may differ.

Look on your gas bill and divide the standing charge by the number of weeks elapsed since the last reading.

**Prepare for the worst with A. Lee-Bentley's program for the Dragon. It will work out your gas and electricity bills before the buff envelopes arrive**

**How it works**  
 5-100 display menu  
 110-180 set variables for electricity bill  
 190-260 calculate, display result  
 270-300 further query option prompt (elec)  
 310-390 set variables for gas bill  
 400-480 calculates and displays result  
 490-520 further query option prompt (gas)  
 530-580 return to menu option  
 590 690 flashing end program message



```

5 REM BILL CHECK/CALC.
6 REM A. LEE-BENTLEY 1983
10 CLS:PRINT@14,"MENU"
20 PRINT@46,"-----"
30 PRINT@100,"(1) ELECTRICITY BILL CALC."
40 PRINT@32,"(2) GAS BILL CALC."
50 PRINT@164,"(3) END PROGRAMME"
60 PRINT@393,"INPUT(1-3)"
70 A$=INKEY$:IFA$=" "THEN70
80 Z=ASC(A$)-48
90 IFZ<1ORZ>3 THEN70
100 ON Z GOTO110,310,590
110 CLS
120 PRINT@2,"ELECTRICITY BILL CALCULATION"
130 PRINT@34,"-----"
140 FORI=0TO500:NEXTI
8342 PRINT:INPUT"ENTER PRESENT READING":A
160 INPUT"ENTER PREVIOUS READING":B
170 INPUT"ENTER PRICE PER UNIT":D
180 INPUT"ENTER STANDING CHARGE":E
190 CLS:PRINT@2,"electricity bill calculation"
200 PRINT@34,"-----"
210 C=A-B:T=C*D+E
220 PRINT@64,"METER READING UNITS COST"
230 PRINT@96,"LAST PRESENT TOTAL AT $ . P"
240 PRINT@128,"....."
250 PRINT@160,B:PRINT@165,A:PRINT@174,C:PRINT@179,D:PRI
NT@184,"$":T
260 FORI=0TO800:NEXTI
270 PRINT@262,"FURTHER QUERY(Y/N)?"
280 K$=INKEY$:IFK$=" " THEN280
290 ON INSTR(1,"Y",K$)GOTO110
300 ON INSTR(1,"N",K$)GOTO530
310 CLS
320 PRINT@5,"*GAS BILL CALCULATION*"
330 PRINT@37,"-----"
340 FORI=1TO800:NEXTI
350 PRINT:INPUT"ENTER PRESENT READING":A
    
```

```

360 PRINT:INPUT"ENTER PREVIOUS READING":B
370 PRINT:INPUT"ENTER WEEKS SINCE LAST READ":D
380 PRINT:INPUT"ENTER PRICE PER THERM":F
390 PRINT:INPUT"ENTER STANDING CHARGE":G
400 CLS:PRINT@5,"*gas bill calculation*"
410 PRINT@37,"-----"
420 C=A-B:F=C*F
430 H=P/D:X=C/D:Y=X/10
440 J=(G+Y+H)*D
450 PRINT@65,"METER READING UNITS COST"
460 PRINT@96,"LAST PRESENT USED AT # . P"
470 PRINT@128,"....."
480 PRINT@160,B":":PRINT@166,A":":PRINT@174,C":":PRINT@
179,F":":PRINT@185,"$":J
490 PRINT@262,"FURTHER QUERY?(Y/N)"
500 IC$=INKEY$:IFIC$=" "THEN490
510 ONINSTR(1,"Y",IC$)GOTO310
520 ONINSTR(1,"N",IC$)GOTO530
530 CLS
540 PRINT@230,"RETURN TO MENU?(Y/N)"
550 E$=INKEY$:IFE$=" "THEN540
560 CLS
570 ONINSTR(1,"Y",E$)GOTO10
580 ONINSTR(1,"N",E$)GOTO600
590 CLS
600 PRINT@204,"THANK YOU *"
610 PRINT@265,"HAVE A NICE DAY*"
620 FORT=0TO400:NEXTT
630 PRINT@168,"*****"
640 PRINT@200,"*"
650 PRINT@232,"*"
660 PRINT@264,"*"
670 PRINT@296,"*****"
680 FORT=0TO400:NEXTT
690 GOTO600
    
```

**LUNAR JETMAN** - 48K ZX  
Spectrum

**LUNAR JETMAN** - For the 48K Sinclair ZX Spectrum

**LUNAR JETMAN** - The Ultimate Intergalactic G.A.S. (Graphic Arcade Simulation) Adventure Space Battle.

**LUNAR JETMAN** - Arcade standard, 100% machine code, incredible sound effects, amazing smooth high resolution graphics, the totally new addictive concept and all those extra features you expect from the **ULTIMATE** games people.

Design - The **ULTIMATE PLAY THE GAME** design team.



**COOKIE** - 16/48K ZX  
Spectrum



**PSSST** - 19/48K ZX  
Spectrum

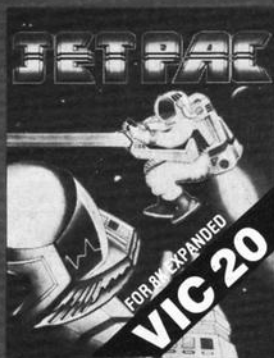

**TRANZ AM** - 16/48K ZX  
Spectrum

**ATIC ATAC** - For the 48K Sinclair ZX Spectrum

**ATIC ATAC** - The super spooky 3D horror G.A.S. (Graphic Arcade Simulation) Adventure Game.

**ATIC ATAC** - Arcade standard, 100% machine code, incredible sound effects, amazing smooth high resolution graphics, the totally new addictive concept and all those extra features you expect from the **ULTIMATE** games people.

Design - The **ULTIMATE PLAY THE GAME** design team.

**JET PAC** - 16/48K ZX  
Spectrum or 8K Expanded  
VIC 20

**ATIC ATAC** - 48K ZX Spectrum

Dealer enquiries welcome. Phone (0530) 411485

These games should be available from **W.H. SMITHS, BOOTS, JOHN MENZIES, LASKYS, SPECTRUM CENTRES**, other large department stores and all good major software retailers. Alternatively, send the coupon to **ULTIMATE PLAY THE GAME** for immediate dispatch by return, subject to availability.

**£5.50** each including VAT, first class postage and packing within UK.

Post this coupon to:  
**ULTIMATE PLAY THE GAME**, The Green, Ashby de la Zouch, Leicestershire, LE6 5JU

Please rush me the following:

LUNAR JETMAN

ATIC ATAC

JET PAC

COOKIE

TRANZ AM

PSSST

JET PAC (8K Expanded VIC 20)

I enclose cheque/PO for £.....

Name .....

Address .....

Post Code .....

## House of Bugs TI-99/4A (Extended BASIC, joystick) £5.95

Temptation Software, 27 Cinque Ports Street, Rye, Sussex

Happily, the only bugs to be found in this program are those to be seen jumping around the screen in the House of Bugs.

The house has a basement, ground, first and second floors and a roof. By controlling your man, one of four, a high score must be obtained by climbing ladders to the upper floors.

Lingering on lower levels results in points being deducted.

When the game starts, the four resident bugs are to be found on the roof.

As play progresses, some will

descend the ladders, eager to leap on to your head.

Your only protection is to jump to the ceiling and drop down on the bug as he passes. This will gain bonus points, but once a square of ceiling has been damaged it cannot be used again until replastered.

Repairs are only carried out when the score reaches 300. For every 600 points gained, the second floor ceiling is repaired and you earn an extra man.

While plastering is in progress the bugs go wild, so whether it's you or those bugs that are hopping by the end of the game depends on how fast those reactions are!

J.W.

instructions	90%
playability	90%
graphics	90%
value for money	90%



## Road Toad Commodore 64 £8.95

Audiogenic, 34-36 Crown Street, Reading, Berks

No home computer, it seems, is complete without its own version of the arcade favourite, Frogger.

This release for the 64 is guaranteed to keep arcade fanatics happy for hours.

For those hermits who have never actually played Frogger, the basic idea is to guide a green frog across a road avoiding fast cars, and through a crocodile infested river.

To cross the river requires skill, leaping on to moving turtles and

# Playing at the speed of byte

## This week's roundup of action games for a range of micros

logs, while avoiding the crocs.

As the game progresses, snakes will appear by the road side and attempt to eat your frog, and the pace gets much faster.

Leaping on to a female frog gains bonus points, and once four frogs have been safely housed in the safe areas at the top of the screen, a new sheet begins.

I particularly liked the graphics on this game — the frog moved very realistically. But the instruct-

ions, which assumed that the owner has played Frogger before, were a little confusing.

Anyone who likes Frogger will find this version extremely satisfying.

D.A.

instructions	60%
playability	75%
graphics	95%
value for money	70%



## Storm Arrows Dragon 32 £7.95

Dragon Data, Kenfig Industrial Estate, Margam, Port Talbot, W. Glamorgan

The object of this game is to shoot the deadly arrows that are flying in all directions around a maze.

Tactics are required, however, because "master arrows" appear and lay eggs on the grid.

These eggs hatch as you shoot the last two arrows. If you successfully clear all the hostile arrows, a new screen is presented in different colours.

Before play starts, you are asked to input three initials for the high score table displayed at the end of the game. Since I have only two initials, I found that I had to

invent a third one!

A good point is that a new name can be input before each round if required by pressing Enter.

There are many other good features, including on-screen scoring with high score, time and round bonuses, and extra points for certain hits.

The graphics are smooth and fast and the game is fun to play and addictive.

The sound is reasonably good with a satisfying twang when a laser is fired. There are no melodious tunes, though — unlike many of the new arcade games.

E.C.

instructions	90%
playability	90%
graphics	90%
value for money	90%



## Barreldrop 48K Spectrum £5.95

Games Machine, Business and Technology Centre, Bessemer Drive, Stevenage, Herts SG1 2DX

An unusual game, written in BASIC, which shows what the Spectrum is capable of without recourse to machine code.

The main section is a variation of Bagatelle. Your character, Gordon, rolls barrels along the roof. When you press space they fall to the ground.

If you press when the barrel is immediately over a drainpipe, you unblock it. Your task is to unblock five drains.

Sometimes if you miss, Gordon's dog Flash will retrieve the barrel and give you another try.

If you succeed in unblocking all

five drains then you get a "surprise" before the next sheet in the form of an unrelated problem or game, for example, mini Space Invaders.

Colour, sound and graphics are all reasonably well used but unfortunately for Games Machine, the big boys have set the standards of animation which we expect from a commercial program.

Although this is a competent and enjoyable game, it lacks polish; each of the sections are of the standard of good magazine listings.

But younger children or inexperienced gamers would enjoy this game.

R.E.

instructions	80%
playability	60%
graphics	59%
value for money	60%



## Laser Snaker 48K Spectrum £5.95

Poppy Soft, The Close, Common Road, Headley, Newbury, Berks

I have seen one or two variations of games where a player has to guide a "snake" round an obstacle course, and this is one of the best I have seen so far.

Although it may seem easy, I

can assure you that it isn't — even at Trainee level, and difficulty 0, which is my level.

There are 15 sheets or playing areas to get through, and after two hours I managed sheet 9, but my fingers refused to cooperate any more.

As an incentive, there is a prize if you manage to complete sheet 15. If you manage this at speed 9, for expert, and difficulty 4, then I would suggest that the prize is a six month stay in a psychiatric

ward to recuperate!

The cursor control keys move the snake round the playing area, and if you should need a rest — and you will — then key P will hold the game for you. Key 0 fires a burst of venom at whatever gets in the way of the snake.

You should have no problems with loading, but I would suggest that you only load this game when you have at least a couple of hours to spare.

Although the graphics are

nothing to write home about, the display is pleasing enough, and the snake movement is very smooth.

Not too fast, and not too slow. I found it a very playable game.

B.B.

instructions	100%
playability	100%
graphics	75%
value for money	100%



# We've got the Aquarius taped!

Now for the first time you can buy cassette based software for your Aquarius. All the excitement of arcade type action at the low, low price of £5.95.

## 'N' Vaders

The classic arcade golden oldie but written in machine code for fast, exciting action. Pit your wits and skills against squadrons of coloured weirdos. Blast them all from the sky - but beware, they get faster and meaner.

## Ed'on

Eat the dots and avoid the planes to win through. An updated version of the addictive arcade game. Accelerate, decelerate, dodge and change lanes. If you manage to avoid destruction you go on to higher things.

**JUST RELEASED**

## Phrogger

A leap in front of all other versions - an arcade quality game with truly amazing graphics. Hop, skip and jump across all the dangers and perils. Take your life in your controls to reach safety.

## Aliens

You are one of the chosen 'Gatherers' selected by your unique abilities and talents. Probe the mysteries of the 'past times' building. Gather the secrets of the Universe. Have you the mental strength to survive and the character to win?

## Chuckman

Based on the ever-popular arcade game with extra extras. Find the quickest route, avoid the meanies and defuse the time bombs to win the day. But beware, this game is addictive, you'll risk sleep and peace of mind.

**AQUARIUS**  
HOME COMPUTER SYSTEM

**AQUARIUS**  
HOME COMPUTER SYSTEM

To: Add-On Electronics Ltd., Units 2, 3 and 4, Shire Hill Industrial Estate, Saffron Walden, Essex CB11 3AQ

Please rush me: \_\_\_\_\_ (qty) 'N' Vader \_\_\_\_\_ (qty) Ed'on  
\_\_\_\_\_ (qty) Aliens \_\_\_\_\_ (qty) Chuckman \_\_\_\_\_ (qty) Phrogger  
Cassettes at £5.95 each inc. p+p and VAT for my Aquarius computer.

I enclose cheque to the value of £ \_\_\_\_\_ or debit my Access/Visa card. No. \_\_\_\_\_

Signature \_\_\_\_\_ Name \_\_\_\_\_

Address \_\_\_\_\_ Postcode \_\_\_\_\_

Credit card holders ring (0799) 25014 (24 hrs) or Telex 81653

**'N' VADERS**



**AQUARIUS** & 16K EXTENSION  
HOME COMPUTER SYSTEM

**ED-ON**



**AQUARIUS** & 16K EXTENSION  
HOME COMPUTER SYSTEM

**Aliens**



**AQUARIUS** & 16K EXTENSION  
HOME COMPUTER SYSTEM

**Chuckman**



**AQUARIUS** & 16K EXTENSION  
HOME COMPUTER SYSTEM

**ADD  
ON  
ELECTRONICS**

Add-On  
Electronics Ltd.,  
Units 2, 3 and 4,  
Shire Hill  
Industrial Estate,  
Saffron Walden,  
Essex CB11 3AQ



# Turning turtle

**Turtle graphics — without a Super Expander? Alan Wilburn explains how it can be done — and on any VIC-20 with 3K or 8K memory expansion**

The lack of the necessary graphics commands and the cost of a Super Expander cartridge inspired this program to allow high resolution drawing on the VIC-20. Before starting to write the program, I decided to meet two requirements.

Firstly, the program had to draw complex shapes using a minimum of commands, with the emphasis on ease of use. Secondly, the program had to be compatible with both 3K and 8K memory expansion.

The first requirement was easily met by using the 'turtle' technique. This is an imaginary pen that can be moved around the screen with two simple commands — turn (x) and draw (x). By repeatedly using these commands, complex shapes could easily be programmed.

At first, the second requirement seemed harder to meet. The high resolution screen uses most of the user RAM from \$1000 to \$1E00, so storing the program in the 3K expansion area would have made it inaccessible to machines with only 8K expansion and vice versa.

The solution was to reduce the size of the high resolution screen and store the VICPEN routines just below the normal screen location from \$1C00 to \$1E00, making it accessible to VICs with either 3K or 8K expansion (see Figure 1).

The program itself assigns four extra commands to VIC BASIC. Listed below is a brief description of each command.

**VICPEN** switches on the high resolution screen and points the pen upwards ready to draw.

**PEN X,Y** (x=0 to 151 Y=0 to 159) sets the start position for the draw command and can also be used to plot an individual pixel.

**TURN (X)** (X=0 to 255) turns the pen through X degrees from its current direction. Greater angles than 255° can be programmed by using the command twice, ie. **TURN (0)**; **TURN (90)** = 270°

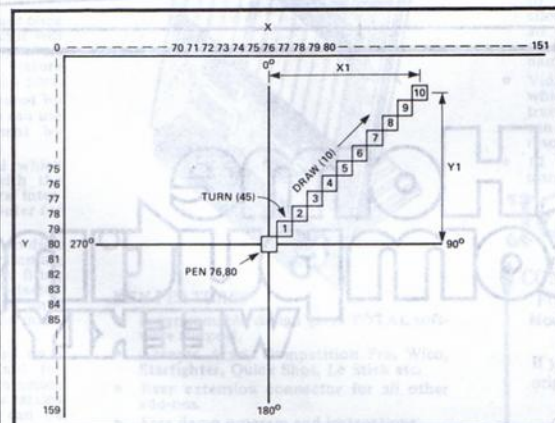

**TURN (0)** returns the pen to the UP direction from any direction.

**DRAW (X)** draws a line of length (x) in the direction determined by the command **TURN (x)**. The value of X defaults to screen limits (151 and 159).

Consider the Demo 1 program along with its graphical representation in Figure 2.

The start co-ordinates of the pen are stored in addresses \$F8 and \$FC by the command **PEN 76,80**. The turn routine converts the 45° angle to radians and stores the result in the floating point store. The Sine and Cosine of the angle are then calculated and also stored as floating point numbers.

The results of these calcula-

tions produce the offsets X1 and Y1 which when added to the current X and Y values produce the new position of the pen.

The draw routine merely adds the value of the offsets X1 and Y1 to the X and Y values as many times as determined by the command **DRAW (10)**.

After entering the program, it should be saved before it is run as any errors may hang up the computer. The program will run on any expanded VIC.

However, if more than 3K expansion is fitted, then the VIC should be reconfigured by **POKE 642,32**; **POKE 648,30**; **SYS 64824** before loading and then omit lines 10 and 20.

Demo 2 and Demo 3 are two short routines which demonstrate

how the commands are used to draw simple shapes. Line 100 prevents the Ready message from corrupting the display. Pressing any key will return the VIC screen to normal.

## Graphic representation of

### Demo 1

where A = Angle = 45° and L = Length = 0  
 $X1 = \text{INT}(\sin(A) * L + 0.5)$   
 $Y1 = \text{INT}(\cos(A) * L + 0.5)$   
 $Y = Y - Y1$

**Demo 1** (draws a line from center of screen at an angle of 45°)

```
10 VICPEN
20 PEN 76,80
30 TURN (45)
40 DRAW (10)
```

The high resolution screen consists of 152 x 160 plottable points where x=0 to 151 and Y=0 to 159.

Figure 1

8K expansion	\$ 2000
Normal video RAM	\$ 1E00
VIC-PEN	\$ 1C00
High resolution screen	\$ 1000
3K expansion	\$ 0400

**Demo 2** draws square

```
10 VICPEN
20 PEN 76,80
30 TURN (90); DRAW (40)
40 TURN (90); DRAW (40)
50 TURN (90); DRAW (40)
60 TURN (90); DRAW (40)
100 WAIT 198,7; SYS12
```

**Demo 3** draws cube

```
10 VICPEN
20 PEN 60,60
30 FOR X=1 to 15
40 READ A
50 TURN (A); DRAW (40)
60 NEXT
100 WAIT 198,7;SYS12
110 DATA 90,90,90,90,45,45,90,45,135,45,135,90,90,180,45
```

## VIC-20 PROGRAM

```

10 POKE56,28:POKE55,0
20 POKE52,28:POKE51,0
30 FORX=7660707679:READA:POKEX,A:NEXT
40 FORX=67370767:READA:POKEX,A:NEXT
60 FORX=7168707338:READA:POKEX,A:NEXT
70 SYS7660
80 FORX=7339707679:READA:POKEX,A:NEXT
90 NEW
100 DATA162,7,189,248,29,157,4,3,202,16
110 DATA247,96,0,28,82,28,133,28,134,206
120 DATA7,207,74,29,153,29,170,28,4,29,7,207
130 DATA67,79,76,79,85,210,68,82,65,215
140 DATA80,69,206,86,73,67,80,69,206,84,85,82,206
150 DATA84,73,205,0,0,0,0,0,0,0,0,0
160 DATA128,64,32,16,8,4,2,1
170 DATA0,16,160,16,64,17,224,17,128,18
180 DATA32,19,192,19,96,20,0,21,160,21
190 DATA64,22,224,22,128,23,32,24,192,24
200 DATA96,25,0,26,160,26,64,27
210 DATA32,124,197,160,5,185,251,1,240,71
220 DATA201,65,144,64,201,91,176,60,132,177
230 DATA162,0,134,11,56,253,173,2,240,19
240 DATA201,128,240,22,189,173,2,240,39,48
250 DATA3,232,208,246,230,11,164,177,169,200
260 DATA185,251,1,232,208,224,166,177,165,11
270 DATA24,105,204,157,251,1,200,232,185,251
280 DATA1,157,251,1,208,246,164,177,200,208
290 DATA180,96,8,201,255,240,42,36,15,48
300 DATA38,201,204,144,34,40,56,233,203,170
310 DATA132,73,160,255,202,240,8,200,185,173
320 DATA2,16,250,48,245,200,185,173,2,48
330 DATA5,32,210,255,208,245,76,239,198,40
340 DATA76,26,199,32,115,0,201,204,144,25
350 DATA201,210,176,21,32,150,28,76,174,199
360 DATA233,203,10,168,185,162,2,72,185,161
    
```

```

370 DATA2,72,76,115,0,32,121,0,76,231
380 DATA199,162,0,160,16,24,32,153,255,169
390 DATA30,133,254,134,253,138,168,72,162,19
400 DATA145,253,24,105,10,200,208,2,230,254
410 DATA202,208,243,104,24,105,1,201,11,208
420 DATA232,169,147,141,2,144,169,21,141,3
430 DATA144,169,252,141,5,144,169,21,141,3
440 DATA2,153,0,150,153,0,151,200,208,247
450 DATA169,16,133,254,132,253,152,162,12,145
460 DATA253,200,208,251,230,254,202,208,246,16
470 DATA3,32,158,215,138,208,4,133,250,133
480 DATA249,24,101,250,144,2,230,249,168,133
490 DATA250,165,249,32,145,211,32,15,220,160
500 DATA29,169,251,32,5,219,160,29,162,246
510 DATA32,215,219,32,104,226,160,2,162,205
520 DATA32,215,219,160,29,169,246,32,162,219
530 DATA32,97,226,160,2,162,200,32,215,219
540 DATA96,32,158,215,134,191,169,241,160,29
550 DATA32,162,219,169,205,160,2,32,77,216
560 DATA162,241,160,29,32,215,219,32,73,216
570 DATA32,170,209,192,152,144,2,160,151,132
580 DATA251,169,236,160,29,32,162,219,169,200
590 DATA160,2,32,80,216,70,102,162,236,160
600 DATA29,32,215,219,32,73,216,32,170,209
610 DATA192,160,144,2,160,159,132,252,208,13
620 DATA32,158,215,134,251,32,253,206,32,158
630 DATA215,134,252,165,251,74,74,74,10,170
640 DATA189,218,2,133,253,189,219,2,133,254
650 DATA165,251,41,7,170,189,210,2,164,252
660 DATA17,253,145,253,166,191,240,3,202,208
670 DATA129,138,164,251,32,145,211,162,241,160
680 DATA29,32,215,219,169,0,164,252,32,145
690 DATA211,162,236,160,29,32,215,219,96,0
700 DATA0,0,135,32,0,0,135,24,0
710 DATA0,0,101,46,224,210,134,101,46,224,210
    
```

# Home Computing WEEKLY

### COME AND JOIN US

We are looking for an enthusiastic journalist to join Britain's brightest computer magazine. An interest in, and a knowledge of, home computers would be a decided advantage, but is not essential. However, an ability to work accurately and under pressure most definitely is!

We would imagine that the successful applicant has already had magazine experience and is presently looking to advance his/her career. If you know otherwise, we are open to persuasion! A competitive salary, which is negotiable, will be paid.

Apply with full C.V. to: Paul Liptrot, Home Computing Weekly,  
145 Charing Cross Rd, London WC2H 0EE.  
All applications treated in strictest confidence.

# AGF

# PROGRAMMABLE JOYSTICK INTERFACE for Spectrum or ZX81



NOW  
AVAILABLE  
from  
SELECTED  
RETAILERS

### PROGRAMMABLE INTERFACE

The AGF Programmable Joystick Interface is a unique design offering the use of any Atari-compatible joystick with absolutely all software, whether it is cassette or ROM cartridge, with the Sinclair Spectrum or ZX81.

The hardware programmable interface requires no additional software and accurately replicates the keys of the computer in a manner which is responsive to absolutely ALL key reading methods, both BASIC and Machine Code.

The interface does not interfere with key operation and can therefore be used simultaneously with the keyboard.

There is no need to remove the interface once fitted as the rear extension connector will accommodate further expansion, i.e. printers or RAM packs etc. This important feature avoids excessive wear to the expansion port.

The key replication principle pioneered by AGF means that your own programs can use eight directional joystick movement by utilising simple key reading BASIC.

Two joystick sockets are provided which share the same keys, for use with the majority of two player games. Several interfaces may be used on the same computer for multiple joystick applications.

The interface is programmed by a two digit code, which is looked up on a programming chart supplied, for each direction and firing button. The two numbers are then selected on a pair of leads which are clipped onto appropriately numbered strips on the interface.

Once configured this can be marked on a Quick Reference Programming Card for storing with the game. As the programming is *not* power dependent the interface retains the last configuration made and can be immediately used when next switched on.

**PLEASE ALLOW 28 DAYS FOR DELIVERY**

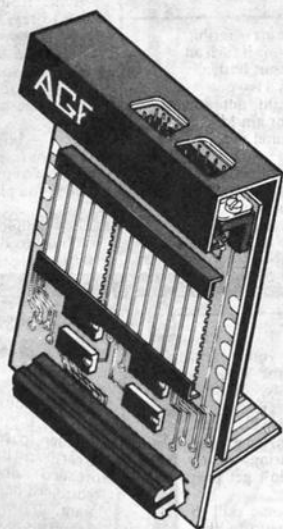

### KEY FEATURES

- \* Programmable design gives TOTAL software support.
- \* Accepts Atari, Competition Pro, Wico, Starfighter, Quick Shot, Le Stick etc.
- \* Rear extension connector for all other add-ons.
- \* Free demo program and instructions.

### PACKAGE CONTENTS SUPPLIED

- Programmable Interface Module as illustrated, complete with clip-on programming leads.
- Self adhesive programming chart detailing how to define which key is simulated by UP, DOWN, LEFT, RIGHT, and FIRE. This can be fixed on to the case of your computer or if preferred the protective backing can be left on. The chart is made of a very durable reverse printed plastic and is extremely easy to read.
- One pack of ten Quick Reference Programming Cards for at-a-glance setting to your games requirements. The card allows you to mark the configuration in an easy to read fashion with space to record the software title and company name.
- Video Graffiti demonstration program which is written totally in BASIC to illustrate how all eight directions and fire can be read. This is also a useful high resolution drawing program.
- 12 months guarantee and full written instructions.

## JOYSTICKS

**CONTROLLERS**

FOR USE WITH OUR INTERFACE Module or VIC 20, Commodore 64, Atari VCS, Atari 400, Atari 800

If you require extra Joysticks for our original interface module mark order 'OLD' Joysticks

**ONLY £7.54 inc VAT + P&P**

**ALL ORDERS CONFIRMED**

FROM: MR/MRS/MISS			
ADDRESS			
SEND C.W.O. (NO STAMP NEEDED) TO: A.G.F. HARDWARE, DEPT.			
FREEPOST, BOGNOR REGIS, WEST SUSSEX, PO22 9BR			
QTY	ITEM	ITEM PRICE	TOTAL
	PROGRAMMABLE INTERFACE	33.95	
	JOYSTICK(S)	7.54	
	PACK(S) QUICK REFERENCE CARDS	1.00	
ONE	VIDEO GRAFFITI	FREE	
ZX81 <input type="checkbox"/> ZX SPECTRUM <input type="checkbox"/>		Please tick	
DEALER ENQUIRIES WELCOME		EXPORT PRICES ON APPLICATION	
		FINAL TOTAL	

# Alien encounters

**Our reviewers guide you through some software encounters of the cosmic kind**

## Cylon Attack 32K BBC £7.90

A&F, 830 Hyde Road, Gorton, Manchester M18 7JD

The term "state of the art" is much over-used in computing, and you should rightly feel sceptical when it is used without thought.

I have thought for quite a while before deciding to describe this

game as a state of the art offering.

My reasons for giving it such an accolade are many, but basically it comes down to this. I have never seen a better thought out and executed game — nor am I likely to see such an original idea for some time to come.

The aim of the game is the obliteration of various types of alien. I've heard this before, you say, but wait.

The aliens appear in an excellent three-dimensional repre-

sentation before your very eyes. You can move in four directions while they dodge and weave in front of you.

The effects — both sound and vision — are most realistic, and the game can even make you feel motion sick if you play it for long enough.

After the annihilation of each wave, you have to dock with the mother ship before the next wave

appears.

Look out for the Tardis as you manoeuvre, and don't shoot the Doctor (he doesn't score anyway!).

instructions	80%
playability	100%
graphics	100%
value for money	100%



## Brain Damage Spectrum £5.95

Silversoft, London House, 271/273 King St, London W6

Brain Damage is a rather weird game, similar to the 'tanks' level in the arcade game Tron.

You have to wander around many levels of mazes, shooting up many different types of alien.

The action all takes place inside the brain of the computer, from what I can work out, and, in the style of Imagine and Ultimate, there is a witty little introduction to set the scene.

For example, the first line reads: "I was just hanging around, on standby as it were; logic levels at an all time low, my printed circuit bored — my keys depressed. Then you came along".

Brings tears to your eyes, doesn't it? The game itself is rather good, actually. Smooth colour graphics and effective use of sound help no end.

It took me a while to get used to the controls, my firing wasn't brilliant and I couldn't get past the third level.

This game takes some skill to play, not just another fire-like-mad-and-you-might-make-the-twenty-seventh-level game. P.S.

instructions	87%
playability	95%
graphics	90%
value for money	94%



## Robopods TI-99/4A £6.95

Virgin Games, 61/63 Portobello Road, London W11

An alien spaceship has descended to earth and has beamed down the dreaded Robopods with the intention of destroying our beloved planet.

You are assigned the task of deactivating the fiendish machines before they self-destruct and blow the whole shooting match to kingdom come.

The pods are rendered harmless by climbing up inside them from underneath, but there are a few snags which tend to make life far from simple.

The robopods are all numbered and they must be deactivated in numerical order.

As you make your panic stricken way from one pod to another, you leave a trail of radio-

active footprints which spell certain death if you pass back over your tracks.

As if that wasn't enough, the ground between each pod is littered with landmines laid by the alien spacecraft.

Stay in one spot for too long, and the pods will blow up anyway.

The only assistance you get is an occasional mat placed over part of your previously laid trail, enabling you to cross your path.

There are five levels of difficulty.

Robopods is a good, well programmed game with excellent graphics and sound. I found it very entertaining.

instructions	90%
playability	80%
graphics	90%
value for money	90%



## Startrek 3,000 48K Spectrum £4.95

dk'tronics, 23 Sussex Road, Gorleston, Gt. Yarmouth, Norfolk

It would be nice if Scotty could beam you up when you hit a bad patch, but that is one of the few options not allowed in this full

version of the old 'Startrek' favourite.

If you do something silly, all you get is old pointy ears saying "I am sorry Captain, but your order seems illogical — it must be the stress".

There are plenty of stress moments, flying a starship by the instruments and view on space provided by the scanners, especially when the Klingons are closing in.

I panicked so much, I actually drove the Enterprise into a star — didn't 'alf upset Spock.

A Help function is provided to itemise the numerous orders to the onboard computer — very helpful, I used it a lot.

With practice, I believe you could become quite adept at controlling the ship and perhaps somewhere in the program, there might be a compliment from Spock waiting to get out!

All in all, a competent rendering of a classic game which gives a good impression of how one imagines it would be like, running a starship from the inside. M.B.

instructions	95%
playability	95%
graphics	90%
value for money	90%



# Just Revealed! Our New Model The Micro-Myte 60 Modem



A professional modem, now with universal couplings, at only an eighth of the price - designed specifically for use with home computers.

Now you can communicate information between compatible micro-computers with your phone, at three times the speed of most other acoustic modems.

The Micro-Myte 60 connects directly to your computer or your cassette recorder via the input/output sockets and transmits or receives up to 60,000 bits per minute of data - twelve times faster than telex and cheaper than first class letter post!

Use the Micro-Myte 60 to send or receive pre-recorded programmes selected data or high resolution screen contents - in black and white or colour - throughout the international telephone network. The universal rubber couplings enable the modem to be used with most types of British and Continental telephones.

Initially designed for use with identical computers, i.e. ZX81 to ZX81 or Spectrum to Spectrum the new Micro-Myte 60 CAN NOW be used to interface the ZX81 to the Spectrum and vice versa, by using the appropriate interface software which is available as

an optional extra. (Limited to resolution of 64 x 32 for screen contents in black and white only and selected data.)

The Micro-Myte 60 is simple to operate and utilises the computing power of the host machine to the full, eliminating costly hardware and the need for a separate power supply.

As a result it is available at the extremely competitive price of **£48.00, including VAT, post and packaging (UK only).**

The price includes the modem, ZX81 and Spectrum software on cassette, connection cable and operating instructions, with a 12 month guarantee.

**There are no hidden extras, making the Micro-Myte 60 an ideal gift for the enthusiast.**

**Optional Extra**  
Interface software (ZX81 to Spectrum and vice versa) - £9.50 (inc. VAT).

Micro-Myte Communications Ltd  
Polo House, 27 Prince St  
Bristol 1  
telephone (0272) 299373

Callers welcome

## To obtain yours now . . . clip the coupon.

I am a ZX81/Spectrum user (specify .....)

Please send me ..... Micro-Myte 60 modem(s) at £48.00 each.

Please send me ..... Interface software(s) at £9.50 each.

I enclose cheque/postal order, payable to  
Micro-Myte Communications Limited.

Name ..... Telephone .....

Address .....

HCW40

# PARAMOUNT SOFTWARE

A Registered Trading Name  
of Workstations Ltd



VIC 20 8K or 16K Expansion

**CHOCABLOC** - A fast moving, pure Machine Code action game, with Chocabloc our hero trying to sort out some Real Cool Choc Bars - until everything goes crazy and the action is on! Arcade standard. Fully featured. Excellent sound and graphics.  
Keyboard or Joystick.

£6.50

**OUTBACK** - Can you use the very sophisticated defence set-up to beat off the cunning Swagmen? How long will you survive? Pure Machine Code action. Fully featured. Superb colour and graphics. A game with a difference. Joystick.

£5.50



Any VIC 20



VIC 20 8K or 16K Expansion

**COUNTDOWN** - Time is important. Accuracy essential. Courage mandatory. But above all, Nerve is the prime attribute needed for your mission as an agent in the crack S.M.U. A Superb Arcade/Graphical Adventure.  
Keyboard or Joystick.

£5.50

**MEGAWARZ** - Where does your fantasy go when your mind leaves your body? Megawarz will take you there you can be sure. High resolution, multi-colour graphics. Sprite graphics. Synthsound. Pure Machine Code action. Arcade standard. A magical planetary trip.  
Keyboard or Joystick.

£7.50



Commodore 64



Dragon 32

**CASTLE OF DOOM**  
Fully implemented graphical adventure. A compelling and devious plot which retains excitement and interest to the end - if you ever reach the end! An experience in adventuring not to be missed. It's user friendly too!

£6.50

**JOGGER** - Truly a jogger amongst joggers. If you have trotted with the rest, now run with the best. Machine Code action. Superlative sound. Creative colour. A quality programme from Paramount.  
Joystick.

£5.50

Any VIC 20.

TRADE  
ENQUIRIES

Tel: (0642) 604470

**WRITING  
MARKETABLE  
PROGRAMMES?**  
Hitch your wagon to  
PARAMOUNT. Send  
for evaluation and  
terms.

Paramount Software, 67 Bishopton Lane, Stockton,  
Cleveland, TS18 1PU. (England)

Chocabloc	£6.50	<input type="checkbox"/>	Name.....
Outback	£5.50	<input type="checkbox"/>	Address.....
Countdown	£5.50	<input type="checkbox"/>	.....
Jogger	£5.50	<input type="checkbox"/>	.....
Castle of Doom	£6.50	<input type="checkbox"/>	.....
Megawarz	£7.50	<input type="checkbox"/>	.....

I enclose cash/cheque/P.O. for £.....  
Overseas orders add £1.00 for airmail.

Turn your CBM64 into a sophisticated synthesiser, a piano, violin, organ, guitar or harpsichord. Woodwind, drums or cymbals and play along with your own or any of the preset rhythms.

You can compose pieces of music note by note, produce explosions, birdsong, trains, thunder, flying saucers and hundreds of other special sound effects for use in your own programs.

All this and an unbelievable range of special features:

4 Wave Forms: Triangle Wave, Saw Tooth Wave, Square Wave, White Noise. Glissando, Pitchbend, Modulation, Layering, Tempo Control, Pretab, Envelope Shaping, Synchronisation, Full Editing, Record, Playback Save, Transfer, 3 Voices, 6 Preset Rhythms and 2 User-Defined Rhythms. Full screen, easy to read, display of effects. Full, easy to follow instruction manual included.

# QUICKSILVA

All games marketed exclusively by Quicksilva Ltd.

Quicksilva Mail Order P.O Box 6 Wimborne, Dorset BH21 7PY. Telephone (0202) 891744.

# ULTISYNTH

for the Commodore 64



**£14.95**

Supplied in box with extensive manual.

Other great games for the Commodore 64 include: **PURPLE TURTLES** - Go Turtle bobbing with the cutest Turtles ever seen! **£7.95** ● **AQUAPLANE** - Ski through Marine Maniacs and other Aquatic obstacles **£7.95** ● **RING OF POWER** - Search through the kingdom for the Mystical Ring **£9.95** ● **QUINTIC WARRIOR** - Stand alone against the sinister Crabman and other mangled mutants! **£7.95**.

## TOWN NATHAN

HOME COMPUTERS, SOFTWARE, BOARD GAMES, ROLE PLAYING GAMES AND BOOKS

### WEST YORKSHIRE'S LOCAL COMPUTER SHOPS

**MORLEY —**

**DRAGON BYTE**

51a Queen Street  
Morley  
Leeds 25  
Tel: 0532 522690

**HEADINGLEY —**

**LAST CHANCE**

10 Ash Road  
Headingley  
Leeds 6  
Tel: 0532 744235

**CROSSGATES —**

**HIEROMANS DELL**

89 Penda's Way  
Leeds 15  
Tel: 0532 641855

We're worth a visit because:

- ★ We've probably the best range of software in the North — and we're improving all the time.
- ★ We've a growing range of computers, peripherals, upgrades and books.
- ★ We've the biggest range of Citadel figures for leagues around.
- ★ We've board and adventure games for all ages from TSR, Games Workshop, Avalon Hill, Victory Games, GDW, Yaquin-to, etc. etc.

**PROGRAMMERS — Assassin Software needs your marketable programs. Give us a call.**

## ARE YOU GETTING ENOUGH FROM YOUR DRAGON?

ONE OF THE MOST VERSATILE DATA HANDLING PROGRAMS EVER PRODUCED IS NOW AVAILABLE FOR THE DRAGON.

### THE NEWLINE DATAFILE

Features:

- VARIABLE NUMBER OF FIELDS AND FIELD LENGTH ● DIFFERENTIAL MULTI COLUMN RANGE SEARCHING & TOTALLING
- INTEGRATED ALPHA/NUMERIC SORT
- MULTIPLE FIELD SEARCHING
- SEARCHING & TOTALLING
- FULL EDIT FACILITIES

This flexible all-purpose program allows even beginners to create systems to suit their own applications — **FOR ONLY £24.95 (TAPE VERSION)**

Available on cassette & disc. Also available for other computers. S.A.E. for full spec. & details of other products available or complete below.

Please send me DATAFILE  PHONE (0626) 63432 ACCESS  
p&p FREE (UK ONLY) OR (0803) 22699BARCLAY

CASSETTE £24.95 inc. VAT

DRAGON DISC £99.95 inc. VAT

DELTA DISC £99.95 inc. VAT

Send to:  
**FORMOSA COMPUTERS & SOFTWARE**  
3 Union Street,  
Newton Abbott TQ12 2JX

Name .....

Address .....

HCW41

## ZX81 PROGRAM

Fizzbuzz is a simple game which tests your mental agility.

All you have to do is to count from 1 to 100, rather rapidly. That sounds easy enough, but each time you come to a number that contains a 5 or is divisible by 5 (such as 25 or 56) you must say fizz instead.

And each number that contains a 7 or is divisible by 7 you replace with buzz.

If a number qualifies for both (such as 35 or 57), then you say fizzbuzz.

The program, which is written in ZX81 BASIC, keeps track of the score, but doesn't give you long to think.

So RUN the program, press NEW LINE to start, and . . . if you want your next go to be a number, press 1. If you want fizz, press 2, buzz 3, and fizzbuzz 4.

If all is well, the program prints your answer, and goes on. If not, you get two asterisks, the right answer, and straight on to the next go.

If you get really good, you can shorten the response time in line 170. Or if you get in a complete tangle, you can allow yourself longer.

When you are getting on top of 5 and 7 you can change them; try replacing 5 with 3 in lines 20, 410 and 440.

# How quickly can you think?

Ever played the party game Fizzbuzz? Now Peter Scott has written a version that you can play against your ZX81



### Main variables

**NS** stores the current number  
**S** the score  
**AS** the answer suggested by the player  
**N** dummy, used in calculating whether a number is divisible by, or contains, 5 or 7  
**Z** dummy  
**X,Y** record whether a number is divisible by, or contains, 5 or 7

### How it works

10-100 give instructions, and print the title  
110-120 initialise the variables NS, S  
130-160 calculate whether the number is divisible by, or contains, 5 or 7 by calling subroutines 400 and 500. The result is stored in Y: 1 for neither, 2 for 5, 3 for 7, and 4 for both  
170-200 reads the player's input, and decides whether it is correct; it prints two asterisks if not  
210-250 keeps the score, and prints the correct answer  
260-280 increases NS by one, checks for the end of the game, and recycles back to 130  
400-460 is a subroutine which checks whether NS is divisible by, or contains, 5  
500-560 does the same for 7  
600 prints the score out of 100



```
10 PRINT AT 3,11; "FIZZBUZZ"
20 PRINT AT 6,0; "SCORE = "; S; TAB
24; "PRESS "
30 PRINT "PRESS " 1 FOR A NUMBER
40 PRINT " 2 FOR FIZZ"
50 PRINT " 3 FOR BUZZ"
60 PRINT " 4 FOR FIZZBUZZ"
70 PRINT "N/L TO START"
80 INPUT N$
90 CLS
100 PRINT AT 0,11; "FIZZBUZZ"

130 LET N$="1"
140 LET S=0
170 GOSUB 400
180 LET Y=X
190 GOSUB 500
200 LET Y=Y+X
220 PAUSE 150
230 LET A$=INKEY$
240 IF A$="" THEN LET A$="5"
250 IF VAL A$<>Y THEN PRINT "
```

```
260 IF VAL A$=Y THEN LET S=S+1
270 PRINT N$; " = "; S; TAB
280 IF Y=1 THEN PRINT "FIZZ"
290 IF Y=2 THEN PRINT "BUZZ"
300 IF Y=3 THEN PRINT "FIZZBUZZ"
310 IF Y=4 THEN PRINT "FIZZBUZZ"
320 LET N$=STR$(VAL N$+1)
330 IF N$="101" THEN GOTO 600
340 GOTO 160
400 LET X=1
410 LET N=(VAL N$)/5
420 IF N=INT N THEN LET X=2
430 FOR Z=1 TO LEN N$
440 IF N$(Z)="5" THEN LET X=2
450 NEXT Z
460 RETURN
500 LET X=0
510 LET N=(VAL N$)/7
520 IF N=INT N THEN LET X=2
530 FOR Z=1 TO LEN N$
540 IF N$(Z)="7" THEN LET X=2
550 NEXT Z
560 RETURN
600 PRINT AT 21,0; "SCORE = "; S;
610
```



# This is the dawning of the age of Aquarius — and your computer christmas.

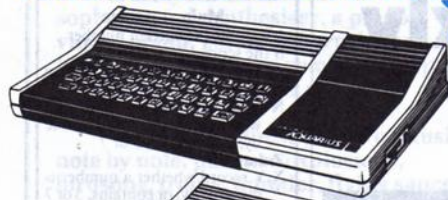

**The Aquarius basic computer — only £49.95**  
 8K ROM, 4K RAM User expandable to 52K, full 49 keys, 16 colours, built-in-Microsoft BASIC, Sound channel.

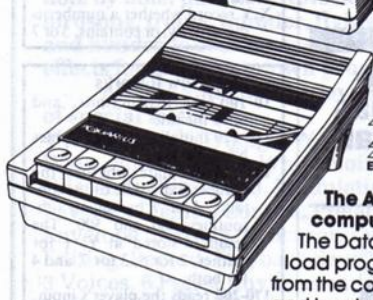

**The Aquarius data computer — only £139.85**  
 The Data Recorder lets you load programs and data from the computer to tape and back again.

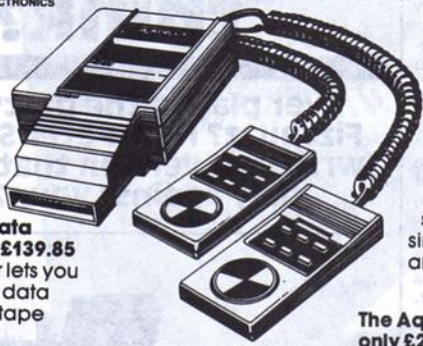

**The Aquarius expanded computer — only £89.90**  
 The Mini-expander adds two joy-sticks, two cartridge ports, two extra sound channels and allows simultaneous use of software and memory cartridges.

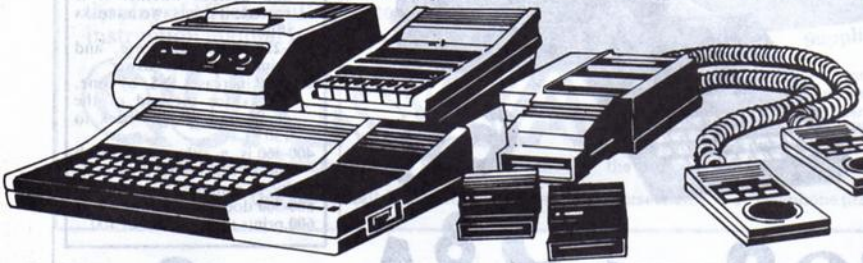

**The Aquarius computer system — only £279.80**  
 8K ROM, 4K RAM User expandable to 52K, full 49 key moving keyboard. Built-in Microsoft BASIC, 280 Microprocessor based, 2 joysticks, 2 cartridge ports, 3-channel sound, data recorder. Plus Printer to provide permanent record of screen content graphics and upper + lower characters. Prints 80 characters per second, 40 cols in width.

## DO YOU WANT TO PLAY GAMES?



**Chess**  
 Play the computer or an opponent

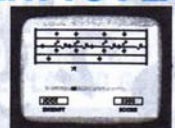

**Melody Chase**  
 Hit the notes, dodge the notes — its addictive.



**Snafu**  
 Little lines that grow — and trap you

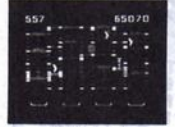

**Burger Time**  
 Make burgers, avoid hot dogs and pickles.



**TRON Deadly Discs**  
 Help the Walt Disney hero win through.



**Advanced Dungeon and Dragons**  
 Find the treasure, evade the dragon



**Night Stalker**  
 On the run from robots in the maze.



**Lock 'n' Chase**  
 Rob the bank, dodge the cops.

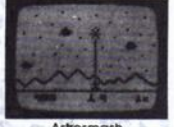

**Astrosmash**  
 Falling rocks, bombs, missiles and UFO's.

## DO YOU MEAN BUSINESS?



**Logo**  
 The state-of-the-art programming language.

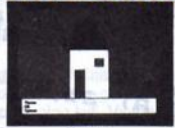

**Finform**  
 Word processing and file maintenance

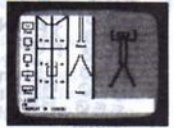

**File Form**  
 Household spreadsheet program

To: Add-On Electronics Ltd. Units 2, 3 and 4, Shire Hill Estate, Saffron Walden, Essex CB11 3AQ.

Please rush me:

- \_\_\_ (qty) Aquarius basic computers at £49.95 each.
- \_\_\_ (qty) Aquarius expanded computers at £89.90 each.
- \_\_\_ (qty) Aquarius data computers at £139.85 each.
- \_\_\_ (qty) Aquarius computer systems at £279.80 each.
- \_\_\_ (qty) Data Recorder at £30.00 each.
- \_\_\_ (qty) Printer at £99.00 each.
- \_\_\_ (qty) Mini Expander at £39.95 each.
- \_\_\_ (qty) 16K Ram Pack at £29.95 each.
- \_\_\_ (qty) Chess £19.95 each.
- \_\_\_ (qty) Melody Chase £19.95 each.
- \_\_\_ (qty) Snafu £15.95 each.
- \_\_\_ (qty) Night Stalker £19.95 each.
- \_\_\_ (qty) Lock 'n' Chase £19.95 each.
- \_\_\_ (qty) Astrosmash £15.95 each.
- \_\_\_ (qty) Burger Time £19.95 each.
- \_\_\_ (qty) TRON Deadly Discs £19.65 each.
- \_\_\_ (qty) Dungeons and Dragons £16.95 each.
- \_\_\_ (qty) Logo £30 each.
- \_\_\_ (qty) Finform £30 each.
- \_\_\_ (qty) Fileform £30 each.

**PLUS NEW GAMES IN CASSETTE FORM at £5.95 each**

- \_\_\_ (qty) "N" Vaders.
- \_\_\_ (qty) Ed-On.
- \_\_\_ (qty) Grid-Bug.
- \_\_\_ (qty) Phrogger.
- \_\_\_ (qty) Chuckman.
- \_\_\_ (qty) D-Fenders.
- \_\_\_ (qty) Aliens.
- \_\_\_ (qty) One-Arm Bandit.

I enclose a cheque for £  
 or debit my Access/Visa Card  
 No. \_\_\_\_\_

Prices include  
 VAT & P+P

Signature \_\_\_\_\_  
 Name \_\_\_\_\_  
 Address \_\_\_\_\_

Postcode \_\_\_\_\_

Credit Card Holders ring (0799) 25014 (24 hrs) or Telex 81653.

**ADD ON ELECTRONICS**  
 Add-On Electronics Ltd.  
 Units 2, 3 and 4,  
 Shire Hill Industrial Estate  
 Saffron Walden  
 Essex CB11 3AQ.

Aquarius, © Mattel Inc. 1982. All rights reserved.  
 Burger Time is a trademark of Data East Inc.  
 © 1982 Data East USA.  
 © TRON Deadly discs is the trademark and used  
 under license from Walt Disney Productions  
 © Advanced Dungeons and Dragons is the  
 trademark and used under license from  
 TSR Hobbies Inc.



# Escape the Apeman — and outshoot the outlaws

Here are two games that will fit into any Spectrum. They are both written by C. C. Stock, who explains how to play

## Apeman

Shipwrecked on the wrong side of Apeman's island, the 15 survivors must cross the island to the safety of the village.

But Apeman is enraged by their presence on his land and is after them.

You must guide the survivors

across the island three at a time, across the marshlands, through the bush and across the river.

You are faster than the Apeman in the open, but slower through the bush and across the marshland. The river will wash you down stream and maybe out to sea. Beware of the snakes.

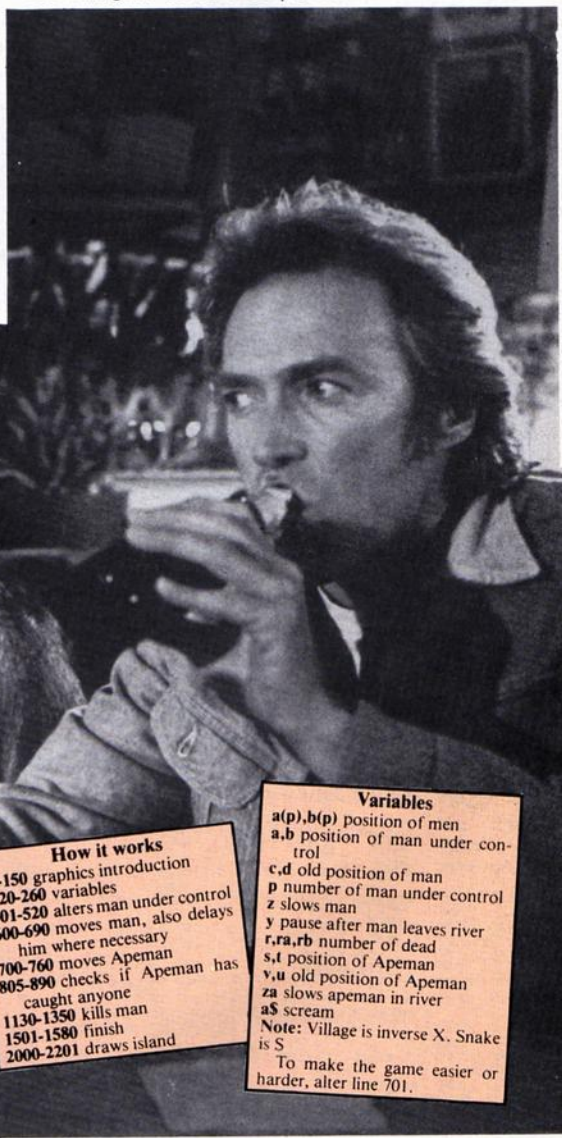

**How it works**  
 5-150 graphics introduction  
 220-260 variables  
 301-520 alters man under control  
 600-690 moves man, also delays him where necessary  
 700-760 moves Apeman  
 805-890 checks if Apeman has caught anyone  
 1130-1350 kills man  
 1501-1580 finish  
 2000-2201 draws island

**Variables**  
 a(p),b(p) position of men  
 a,b position of man under control  
 c,d old position of man  
 z slows man  
 y pause after man leaves river  
 r,ra,rb number of dead  
 s,t position of Apeman  
 v,u old position of Apeman  
 za slows apeman in river  
 a\$ scream  
 Note: Village is inverse X. Snake is S  
 To make the game easier or harder, alter line 701.

## Outlaws

So you think you're fast with a gun. But are you fast enough? Red Jake and his gang of five outlaws are out to get you.

You enter the town from the west, slowly stalking along the streets. You see your first man to your right. He turns. You turn.

The first shots are fired...

There are five controls. 5 turns left. 6 turns round. 7 moves forward. 8 turns right. 0 shoots.

As you wander round the streets, you will only see the outlaws in the same street as yourself. The outlaws are randomly repositioned to make it harder.

**How it works**  
 130-140 turn the lawman left or right, and line 160 draws the right man  
 200-298 check to see if any outlaws are in view and then print them  
 300-380 turn the outlaws to face you if necessary and then shoot

**Variables**  
 k no of dead outlaws  
 y,x position of lawman  
 a,b direction of lawman  
 a\$ contains man  
 a(n),b(n) position of outlaws  
 C(n),d(n) direction of outlaws  
 e(n) delays outlaws one move  
 s no of shots left





# SPECTRUM PROGRAMS

```

b/4)=(y+2)/4 THEN PRINT AT a(n),
b(n); INK 2; a$(c(n)+3,d(n)+3); AT
+1,b(n); a$(c(n)+3,d(n)+4);
GO TO 300
TO 300
IF b(n)=x THEN IF INT(x/4)
THEN PRINT AT a(n),b(n); IN
a$(c(n)+3,d(n)+3); AT a(n)+1,
a$(c(n)+3,d(n)+4); GO TO 34
(140) LET e(n)=0; PRINT AT a(n),b
; AT a(n)+1,b(n);
NEXT n
FOR n=1 TO 10; NEXT n
GO TO 100
REM Gunfight
IF d(n)*(x-b(n))>0 THEN IF
(x-b(n))<14 THEN LET e(n)=e
+1; IF e(n)=2 THEN GO TO 1450
LET c(n)=0

```

```

LET d(n)=2; IF x<b(n) THEN
d(n)=-2
GO TO 250
IF c(n)+y-a(n)>0 THEN IF
(y-a(n))<14 THEN LET e(n)=e
+1; IF e(n)=2 THEN GO TO 1450
LET d(n)=0
LET c(n)=2; IF y<a(n) THEN
c(n)=-2
GO TO 250
REM Gun
IF s=0 THEN GO TO 205
BEEP .02,12; BEEP .1,24; LE
-1
FOR n=1 TO 5
FOR n=1 TO 5
THEN SCREEN$(y+a*n,x+b*n)<>
NEXT n
FOR n=1 TO 6

```

```

IF a(m)=y+a*n THEN IF b(m)=
a(n) THEN PRINT AT a(m),b(m);
; AT a(m)+1,b(m); INK 2; IU"; LE
a(m)=0; LET b(m)=1; LET k=k+1;
GO TO 100
NEXT m; GO TO 100
REM Move OUTLAWS
LET l=INT(RND*6+1)
IF b(l)=1 THEN GO TO 210
PRINT AT a(l),b(l); AT a
(l)+1,b(l);
LET a(l)=INT(RND*11)*2; LE
T b(l)=INT(RND*15)*2+2; IF SCORE
(a(l),b(l))<> OR a(l)=y OR
b(l)=x THEN LET b(l)=b(l)-2; GO
TO 210
REM ** Variables etc **

```

```

FOR n=0 TO 20 STEP 4: PRINT
AT n,0; LL LL LL LL LL LL L
LL LL LL LL LL LL LL LL LL
NEXT n
LET a=2; LET b=0
DIM a$(5);
a$(1)=EF; LET a$(3)
="AB";
DIM d(5); DIM b(6); DIM c(6)
IM d(5); DIM e(5)
FOR n=1 TO 6; LET a(n)=INT
(RND*11)*2; LET b(n)=INT(RND*14)
*2+4; IF SCREEN$(a(n),b(n))=
THEN GO TO 1150
LET b(n)=b(n)-2
LET c=a; LET a=-b; LET b=c;
LET c(n); LET d(n)=b; NEXT b=c;
LET e=12; LET k=0; LET a=0;
LET b=2; LET y=12; LET x=0;
GO TO 100
REM FINISH

```

```

1410 PRINT AT 10,9; FLASH 1; PAP
ER 1; INK 6; YOU HAVE WON; AT
11,7; AGAINST ALL ODDS"; AT
1420 FOR n=1 TO 40; BEEP .05,RND
*20+n; PAUSE 2; NEXT n; GO TO 14
60
1450 FOR n=1 TO 3; BEEP .02,12;

```

```

BEEP .1,24; NEXT n; PRINT AT y,x
; AT y+1,x; INK 3; IU";
1450 PRINT AT 7,11; FLASH 1; PAP
ER 1; INK 6; YOU LOST; AT 8,5;
AGAINST HOPLESS ODDS"; AT 8,5;
1460 PRINT AT 11,6; PAPER 4; YOU
KILLED"; OUTLAWS";
1465 IF s=0 THEN PRINT AT 14,5;
PAPER 6; But run out of Bullets";
1470 FOR n=1 TO 5; BEEP 1,RND*10
-20; NEXT n; BEEP 1,-20
1480 PRINT AT 19,5; Press any ke
y to continue";
1490 IF INKEY$="" THEN GO TO 149
0

```

```

1495 GO TO 1000
1901 REM INTRODUCTION
1910 BORDER 4; PRINT AT 5,8; O
UTLAWS";
1920 PRINT AT 6,0; Red Jake and
his gang have come to release th
eir man from your custody. Can
you the Lawman, kill all six first
1930 PRINT AT 14,5; Press 7 to m
ove forward"; PRINT TAB 5; Press
6 to turn round"; PRINT TAB 5;
Press 8 to turn left"; PRINT TAB
5; Press 0 to turn right"; PRIN
T TAB 5; Press 0 to shoot";
MM001 REM Graphics; AA BB CC DD
MM10 F05 HH IJJ KK
MM10 F05 n=0 TO 98; READ a; POKE
"AA"+n,a; NEXT n
2000 PAUSE 0; GO TO 1000

```

```

1410 PRINT AT 10,9; FLASH 1; PAP
ER 1; INK 6; YOU HAVE WON; AT
11,7; AGAINST ALL ODDS"; AT
1420 FOR n=1 TO 40; BEEP .05,RND
*20+n; PAUSE 2; NEXT n; GO TO 14
60
1450 FOR n=1 TO 3; BEEP .02,12;
BEEP .1,24; NEXT n; PRINT AT y,x
; AT y+1,x; INK 3; IU";
1450 PRINT AT 7,11; FLASH 1; PAP
ER 1; INK 6; YOU LOST; AT 8,5;
AGAINST HOPLESS ODDS"; AT 8,5;
1460 PRINT AT 11,6; PAPER 4; YOU
KILLED"; OUTLAWS";
1465 IF s=0 THEN PRINT AT 14,5;
PAPER 6; But run out of Bullets";
1470 FOR n=1 TO 5; BEEP 1,RND*10
-20; NEXT n; BEEP 1,-20
1480 PRINT AT 19,5; Press any ke
y to continue";
1490 IF INKEY$="" THEN GO TO 149
0

```

```

1495 GO TO 1000
1901 REM INTRODUCTION
1910 BORDER 4; PRINT AT 5,8; O
UTLAWS";
1920 PRINT AT 6,0; Red Jake and
his gang have come to release th
eir man from your custody. Can
you the Lawman, kill all six first
1930 PRINT AT 14,5; Press 7 to m
ove forward"; PRINT TAB 5; Press
6 to turn round"; PRINT TAB 5;
Press 8 to turn left"; PRINT TAB
5; Press 0 to turn right"; PRIN
T TAB 5; Press 0 to shoot";
MM001 REM Graphics; AA BB CC DD
MM10 F05 HH IJJ KK
MM10 F05 n=0 TO 98; READ a; POKE
"AA"+n,a; NEXT n
2000 PAUSE 0; GO TO 1000

```

```

20101 DATA 56,254,56,56,124,124,1
0,168,56,256,56,40,108,108,108,108
0,110,0
20104 DATA 20,10,7,0,0,0,10,20,30,20,
104,0,104,0,104,0,104,0,104,0,104,0,
107,0,107,0,107,0,107,0,107,0,107,0,
103,0,103,0,103,0,103,0,103,0,103,0,
107,0,107,0,107,0,107,0,107,0,107,0,
140,0,140,0,140,0,140,0,140,0,140,0,
110,0,110,0,110,0,110,0,110,0,110,0,
400,0,400,0,400,0,400,0,400,0,400,0,
200,0,200,0,200,0,200,0,200,0,200,0,
601 FOR n=1 TO 6; PRINT a(n);
b(n); c(n); d(n); e(n);
NEXT n

```

# ANIROG SOFTWARE

COMPUTER GAMES  
OF TOMORROW  
AVAILABLE

**NOW!**

**AS SEEN ON  
T.V.!!**



HEXPERT



MOON BUGGY



SKRAMBLE



3D TIME TREK

COMMODORE 

**NEW**

## GALAXY

AVOID CAPTURE BY THE ALIEN MOTHER SHIPS TRACTOR BEAM AS THE FIGHTERS DIVE BOMB YOU. 100 SCREENS WITH A TWO PLAYER OPTION. K.B./J.S. £7.95

**KONG** K.B./J.S. £7.95

4 SCREENS WITH BRILLIANT ANIMATED GRAPHICS

**SKRAMBLE** J.S. £7.95

6 SECTORS TO TEST YOUR SKILL

**HEXPERT** J.S. £7.95

TRAIN BERT TO BE HEXPERT ON THIS 3D HEXAGONAL PYRAMID

**MOON BUGGY** J.S. £7.95

MANOEUVRE YOUR PATROL CRAFT OVER GIANT POT HOLES AS YOU DEFEND THE MOON BUGGY FROM ALIEN ATTACK

**FROG RUN** K.B./J.S. £5.95

A POPULAR ARCADE GAME. FUN FOR THE WHOLE FAMILY

**3D TIME TREK** K.B./J.S. £5.95

SPECTACULAR 3D GRAPHICS STAR TREK GAME

**DUNGEONS** K.B. £6.95

ENTER THE REALMS OF FANTASY IN THIS ROLE PLAYING GAME

**DARK DUNGEONS** K.B. £6.95

2ND IN THE SERIES OF FOUR. DEFINITELY NOT FOR THE FAINT HEARTED

**NEW APPROVED GAMES FOR  
THE STACK LIGHT RIFLE**

**INDIAN ATTACK £5.95**

**COSMIC COMMANDO £5.95**

**VENGEANCE OF ZENO £5.95**

24 HR. CREDIT CARD SALES HORLEY (02934) 6083

PAYMENT BY CHEQUE, P.O., ACCESS/VISA

8 HIGH STREET HORLEY, SURREY.

Overseas 50p post & packaging

**TRADE ENQUIRIES WELCOME**

29, West Hill, Dartford, Kent. (0322) 92513/8



# HAVE YOU BEEN INVOLVED IN A MYSTERIOUS ADVENTURE RECENTLY?

If so, it is quite probable that you are presently suffering from TIS, more commonly known as Total Involvement Syndrome.

TIS manifests itself in a number of ways, one of the most dramatic symptoms being a victim's complete inability to feel at ease in the world of reality. Other symptoms include insomnia, a desperate need to play a Mysterious Adventure, and an overwhelming sense of acute enjoyment.

Experts believe that TIS is usually contracted as a result of prolonged exposure to Mysterious Adventures, this is commonly caused by owning any of the following Home Computers:-

48K SPECTRUM, BBC MODEL A OR B, TRS80, COLOUR GENIE, ATARI 400/800, COMMODORE 64, DRAGON 32, 16K ZX81, LYNX etc.

When questioned about this epidemic, a representative of DIGITAL FANTASIA, a company who are actively involved in research and development work on Mysterious Adventures said, "There is probably no cure for TIS other than mains failure, faulty RAM chips etc. which can be at best only a Temporary solution". "In the absence of a more permanent cure, I would advise TIS sufferers to submit to the Syndrome and obtain Mysterious Adventures from any sources available to them". "TIS is highly contagious and in view of the current Worldwide Epidemic, I would say enjoy it while you can, resistance is futile".

If you have a BBC Computer, Commodore 64, 48K Spectrum, Atari 400/800, or Dragon 32 you can obtain Mysterious Adventures in any of the following dosages:-

- |                            |                           |                          |
|----------------------------|---------------------------|--------------------------|
| 1) THE GOLDEN BATON        | 5) ESCAPE FROM PULSAR 7   | 8) THE WIZARD AKYRZ      |
| 2) THE TIME MACHINE        | 6) CIRCUS                 | 9) PERSEUS AND ANDROMEDA |
| 3) ARROW OF DEATH (PART 1) | 7) FEASIBILITY EXPERIMENT | 10) TEN LITTLE INDIANS   |
| 4) ARROW OF DEATH (PART 2) |                           |                          |

Each Dose costs £9.95 including V.A.T. and Postage. Excellent quantity Discounts are available for Pushers.

D.F. MENTAL HEALTH WARNINGS. MYSTERIOUS ADVENTURES CAN SERIOUSLY DAMAGE YOUR SENSE OF REALITY.

For BBC, 48K Spectrum order from:-

**DIGITAL FANTASIA**

24 NORBRECK ROAD, NORBRECK, BLACKPOOL, LANCASHIRE, ENGLAND FY5 1RP. TEL. (0253) 591402

For Atari, Commodore 64, Dragon 32 order from:-

**CAMEL SOFTWARE**

51 FISHERGATE, PRESTON, LANCASHIRE, ENGLAND. TEL. (0772) 53057



# Mysterious Adventures

## WHAT ARE MYSTERIOUS ADVENTURES?

**MYSTERIOUS:** (Adjective):- "Baffling, full of mystery, strange or unaccountable".

**ADVENTURE:** (Noun):- "An enterprise full of risk or danger, an experience of unforeseen events endangering the participants life, a gamble on failure or success".

To start play on a MYSTERIOUS ADVENTURE is to take a step out of the world of reality and into the world of dreams. Your computer is your guide on these fantastic journeys in time and space where danger is ever present and solutions to problems seldom come easy.

By typing in simple commands in plain English you can "talk" to your computerised guide and tell it what your next actions are to be.

MYSTERIOUS ADVENTURES bring a frightening reality to the surreal situations in which you will find yourself. You will become involved in these strange worlds of the imagination, you will feel anger when things seem to be moving against you, you will feel elated when you overcome obstacles that are set in your way. Eventually you will feel overjoyed as you reach the climax of your mission and success is yours.

Any MYSTERIOUS ADVENTURE is not a mission to be taken lightly, success will never be instant - just as Rome was not built in a day, so each Adventure can rarely be completed in one session. To this end a "SAVE GAME" feature has been incorporated in each of the Adventures. This means that at any given time during play of an Adventure, you can store on tape your precise whereabouts, your equipment carried, and any other pertinent details about your present status.

## NEW DEVELOPMENTS ON MYSTERIOUS ADVENTURES

Over the past few years, Adventure programs on Computers have almost always been presented in the classic "Text only" mode. For most Adventure players this has indeed been the way they prefer to play Adventures. The mental imagery generated by such an approach is limited only by the player's own imagination. One of the main reasons for the "Text only" approach has been the lack of hardware capabilities with regard to Graphics resolution - Pictorial Adventures could at best be only very limited in scope.

This situation is changing now however, and Brian Howarth, author of the MYSTERIOUS ADVENTURES series, has spent many hours incorporating Graphics into the Adventures. By working in close conjunction with Jon Blacow, a professional Artist, Brian has produced a series of extremely vivid and imaginative Adventures. Each MYSTERIOUS

ADVENTURE now features, in addition to the Text description, pictorial "views" of your current location and surroundings. As you enter each new location, a high resolution, colour picture is rapidly drawn. The effect of this is to bring much more reality to the Scenario, you can actually see the situation you are faced with and act accordingly. It must be stressed that each picture has been designed so that it will enhance, rather than conflict with your mental imagery. At the single stroke of a key, you can erase the picture and carry on with your Adventure in text only if this is your preference. We are confident that no other Adventure programs can boast such breathtaking realism and imagination combined with the flexibility and ease of play that have made MYSTERIOUS ADVENTURES such a phenomenal worldwide success.

In addition, the Adventures now features full sentence decoding as standard. These mean that you are no longer restricted to inputting single or two-word commands. You can now type in whole sentences in more or less plain English. Your computer will quickly analyse the sentence and perform a whole string of your commands. Just another feature designed to maximise your enjoyment of these world beating games!



The "New style" MYSTERIOUS ADVENTURES are currently available for the 48K SPECTRUM, COMMODORE 64. More releases are planned this year which will include DRAGON 32, ORIC-1, APPLE II & IIe, ATARI, LYNX, MATTEL AQUARIUS, IBM PC etc. Please write or phone for availability.

## ZX81 AND SPECTRUM PROGRAM

# Mind the doors as you try to bag the gold

This game was written on the ZX81, but with the Spectrum in mind. The program will run on both computers as it stands, but with a little thought many improvements can be made for the Spectrum — colour, sound, UDG for character (0 in the listing) etc.

The idea is simple, move from the bottom of the screen up through the grid to collect the treasure at the top (perhaps a UDG on the Spectrum?)

Meanwhile your presence on

### Treasure can be yours unless you're trapped by the doors. Ray Elder's game is for both the ZX81 and Spectrum. He includes tips to enhance the program for the Spectrum

the floor may trigger the doors which close in on you. Speed and planning are necessary to achieve the highest score. I tried to create

a simple but interesting game — I hope you enjoy it.

Keys are Z/X for left and right and K/M for up and down.

#### Hints on conversion

I specifically wrote this game using standard characters in order to enable conversion. A few other points to note:

**DIM FS (6,32)** most BASICs accept and require only DIM FS(6), the 32 is the length of each element and is the length of the Sinclair screen. You will need : LET FS(6) = "32 spaces" added to your program

**INT (RND\*20+6)** produces a random number between 6 and 25

**Line 90** Most BASICs need LET MIDS (FS(I),INT (RND\*20+6),1)

**INKEYS** lines 400/410: probably need to replace by a previous line G\$=INKEY\$ and as Sinclairs return 1 for true and 0 for false, you may have to change the signs if your machine returns -1 for true. Also statements "IF L" may have to be written in full (if L (greater than, less than) 0 etc.) Note: AS needs to have as many characters as FS(6) — 32 in listing — pad out with extra spaces

**L.425** replace AS (X1+1) with MIDS(AS,X1+1,1)

**L.440** replace FS statement by MIDS(FS(INT((Y1+1)/3), X1+1,1) Print at Y,X; Positions print at row Y, column X

#### Variables

**A(17)** holds present position of the "door" on each line  
**FS(6,32)** 1-5 are the grid lines : 6 is 32 spaces to wipe a line

**HS** high score

```
1 REM *****
2 REM * SALVAGE *
3 REM *****
5 GO SUB 3000
7 REM *****
8 REM * INITIALISE *
9 REM *****
10 DIM A(17)
20 DIM F$(6,32)
30 LET HS=0
40 LET C=31
50 LET B=0
60 LET S=0
70 FOR I=1 TO 5
80 LET F$(I)=""
*****
90 LET F$(I,INT (RND*20+6))=""

100 NEXT I
110 LET Y=17
115 LET T=0
120 LET X=1
130 LET A$=""
£ £ £ £ £ £ £
140 LET A(1)=-1
150 FOR I=2 TO 14 STEP 3
160 LET A(I)=-1
170 LET A(I+1)=B
180 LET A(I+2)=C
190 NEXT I
200 LET A(17)=-1
210 LET Z=0
287 REM *****
288 REM * SCREEN *
289 REM *****
290 CLS
300 PRINT "SCORE=" ; S ; "HI-SCORE
= " ; HS ; A$
310 FOR I=1 TO 5
320 PRINT F$(I)
330 PRINT TAB B ; ">" ; TAB C ; " * " ; T
AB B ; " * " ; TAB C ; "<"
340 NEXT I
350 PRINT AT Y,X ; "0"
397 REM *****
398 REM * PLAYER MOVE *
399 REM *****
400 LET Y=INT (RND*20+6)
```

#### How it works

5 GOSUB for instructions  
10-60 set initial values of variables

70-100 for each array 1-5 of FS set it to 32 "stars", then replace one, at random, with a space

110-130 more variables

140-200 set each element of A to -1 if FS row, or 0 or 31 for "door" position

210 zero flag

290 clear screen (Spectrum set BORDER/PAPER/INK colours?)

300-350 draw screen

400-410 see if key is being pressed and, if so, store next position in Y1 or X1

420 if you have returned with some goodies GOTO 1000

425 if you have reached the goods, GOSUB 1500

430 if you are on line one GOTO 460

435 L = 1 if an FS line, 0 if other position

440 if not at a space on FS line, GOTO 600

445 if all OK GOTO 460

450 L = flag for position

455 check to prevent movement into a 'prods' tail

460 if no move has been made jump to 600 — this prevents flickering

470 wipe old character, print in new position

480-490 update X and Y to new position

600 if on FS line GOTO start of main loop. Also 1 in 5 chance of moving door (change .8 to give more or less frequent movements)

610-630 move appropriate 'door' one place to left or right

640 if character hit GOTO 2000

650 update new position to A(Y)

660 GOTO main loop

1000 if complete set of items salvaged GOTO 1080

1010 move character, print message

1020-1040 update score, zero flag

1050-1070 GOSUB pause, wipe, then continue

1080-1140 give a bonus for clearing sheet, reset variables, GOTO draw new sheet

1200-1230 pause, wipe line 18, return



## ZX81 AND SPECTRUM PROGRAM

```

455 IF (A(YI)>=XI AND L) OR (A(
YI)<=XI AND NOT L) THEN GO TO 60
0
460 IF X=XI AND Y=YI THEN GO TO
600
470 PRINT AT Y,X;" ";AT YI,XI;"
D"
480 LET X=XI
490 LET Y=YI
597 REM *****
598 REM * PROD MOVE *
599 REM *****
600 IF A(Y)=-1 OR RND<.8 THEN G
O TO 400
610 LET E=(Y/3=INT (Y/3))
620 LET D=A(Y)+E-(E=0)
630 PRINT AT Y,A(Y);" ";AT Y,D;
("<" AND NOT E)+(">" AND E)
640 IF D=XI OR D=X THEN GO TO 20
0
650 LET A(Y)=D
660 GO TO 400
997 REM *****
998 REM * SUCCESS *
999 REM *****
1000 IF A$=F$(6) THEN GO TO 1080
1010 PRINT AT Y,X;" ";AT YI,XI;"
0";AT 18,0;"WELL DONE : SCORE ="
.
1020 LET S=S+100
1030 PRINT S;AT 0,6;S
1040 LET Z=0
1050 GO SUB 1200
1070 GO TO 480
1080 PRINT AT 18,0;"BONUS +1000"
1090 LET S=S+1100
1100 PRINT AT 0,6;S
1110 GO SUB 1200
1120 LET B=1
1130 LET C=30
1140 GO TO 110
1200 FOR I=1 TO 50

```

```

1210 NEXT I
1220 PRINT AT 18,0;F$(6)
1230 RETURN
1497 REM *****
1498 REM * ROUTINE *
1499 REM *****
1500 IF Z=1 THEN LET XI=X
1510 IF Z=1 THEN RETURN
1520 LET A$(XI+1)=" "
1530 LET Z=1
1550 RETURN
1997 REM *****
1998 REM * CRASHED *
1999 REM *****
2000 FOR I=1 TO 20
2010 PRINT AT Y,X;" ";AT Y,X;"0"
;AT Y,X;"X"
2020 NEXT I
2030 PRINT AT 18,0;"SQUASHED...
PRESS A KEY TO PLAY"
2040 IF S<=HS THEN GO TO 2070
2050 PRINT "A NEW HI-SCORE :";S
2060 LET HS=S
2070 IF INKEY$="" THEN GO TO 204
0
2080 GO TO 40
3000>CLS
3010 PRINT TAB 12;"RESCUE."
3020 PRINT AT 3,0;"MOVE YOUR MAN
- 0 -UP THE SCREEN TO RESCUE THE
BAGS OF GOLD."
3040 PRINT AT 8,0;"KEYS : Z TO M
OVE LEFT",TAB 7;"X TO MOVE RIGHT
",TAB 7;"K TO MOVE UP",TAB 7;"M
TO MOVE DOWN"
3050 PRINT AT 16,0;"BEWARE OF TH
E MOVING PRODS WHICHARE SLOWLY C
LOSING IN ON YOU."
3060 PRINT AT 21,4;"PRESS ANY KE
Y TO PLAY"
3070 IF INKEY$="" THEN GO TO 307
0
3080 RETURN

```

## TOP SAVINGS

PRINTERS - Also Available Seikosha, Oki, Star, Qume, Olivetti, TEC, Mannesman Tally.

		£
<b>Epson</b>	RX80	229
	RX80 F/T	256
	FX80 F/T	335
	FX100 F/T	430
<b>Diablo</b>	630 (RO)	1699
	TP1	299
<b>Smith Corona</b>		
<b>Juki</b>	6100	350
<b>Ricoh</b>	RP1300S	945
	RP1600S	1165
<b>Brother</b>	HR15	419

## COMPUTERS

		£
<b>Commodore</b>	8096	735
	64	165
	1541	165
<b>Epson</b>	HX20	375
	QX10	1600
<b>Spectrum</b>	48	109

Prices exclude VAT. Next day insured delivery £10 Monday to Friday 9.00-6.00. Phone for stock availability and out of hours collection arrangements.

### MAYFAIR MICROS

5th FLOOR 65 DUKE STREET LONDON W1 Telephone 629 2487

## TEXAS INSTRUMENTS

TI 99/4A Solid State Software

Some of our Crazy Prices for Software

### ITEMS IN STOCK

EXTENDED BASIC	£45.00
MINI MEMORY	£45.00
TI LOGO II	£65.00
EDITOR ASSEMBLER	£62.00
BLASTO	£10.50
PARSEC	£24.50
TUNNELS OF DOOM	£20.80
SOCCER	£12.50
MUNCHMAN	£24.50

POST & PACKING FREE—VAT INCLUDED  
SEND S.A.E. FOR FULL PRICE LIST  
PLEASE MAKE CHEQUES PAYABLE TO

### PARCO ELECTRICS

4 DORSET PLACE, NEW STREET  
HONITON, DEVON, EX4 8QS  
TEL: HONITON (0404) 44425

# PLAY ALL DAY WITH THE LATEST AND GREATEST SOFTWARE TO BE SEEN ON SCREEN!

## PLAY ALL DAY!

**JANUARY 6th 7th 8th**

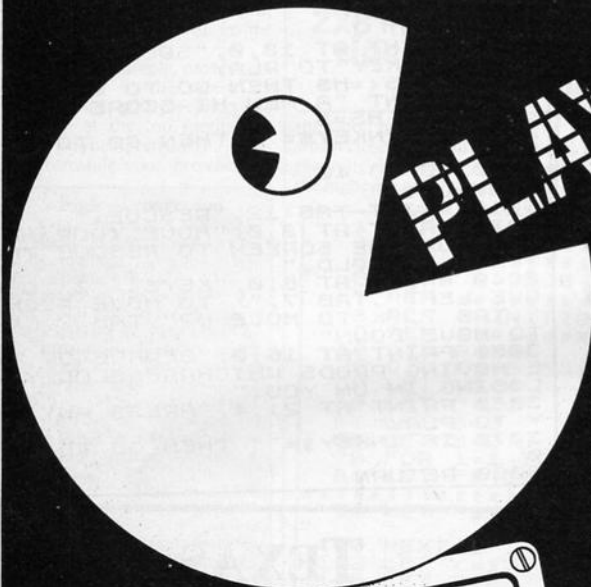

January 6th 7th 8th are the dates when you can play all day with the very latest in software on the very best computers, including Atari, Vic 20 and 64, ZX plus Spectrum, Oric, Dragon and BBC A & B. All will be on display at **The London Home Computer Show!** Once again the emphasis will be on the lower end of the price bracket, with computers from £50 up to £300.

Play all day, try or buy it's all there at the greatest home computer show on earth!

Friday 6th January 1984 -

10.00 a.m. - 6.00 p.m.

Saturday 7th January 1984 -

10.00 a.m. - 6.00 p.m.

Sunday 8th January 1984 -

10.00 a.m. - 4.00 p.m.

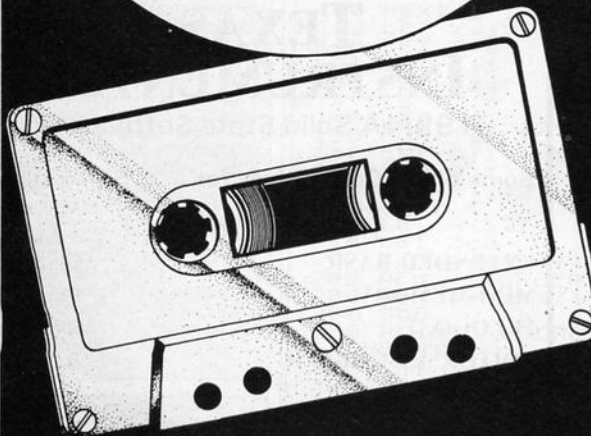

The London Home Computer Show,  
Royal Horticultural Society's New Hall,  
Greycoat Street,  
London S.W.1.

Admission Adults £2.50  
Children under 16 £1.50

# THE LONDON HOME COMPUTER SHOW

HORTICULTURAL SOCIETY'S NEW HALL, WESTMINSTER

## Memory Game Oric £3.95

Stour Computing, 16 Old Bridge Road, Bournemouth

A version of the familiar Pairs or Pelmanism game, usually played with a pack of cards.

Twelve symbols are secretly plotted over a grid on the screen and the players, up to four of whom can take part, take turns in selecting positions.

The symbols at the chosen pair of positions are briefly revealed and re-hidden if they do not match.

Since there are 48 positions the maximum number of pairs is 24, and a point is awarded for successful choice.

The 48K version has an attractive jingle not available on the 16K and, slightly more important, it also has instructions. However, 16K owners who

couldn't figure out how to play the game probably wouldn't get as far as loading the program in the first place.

Having said that, I had some difficulty in loading the 48K version, but once that had been mastered, I found the program was clearly presented and attractively laid out.

Nine of the 12 symbols are re-defined characters — why were the other three left unattended to?

Simple, but fun, this game would appeal to the younger members of the family. P.S.W.

instructions	75%
playability	65%
graphics	65%
value for money	70%



## Puzzler Dragon 32 £6.95

Shards Software, 189 Eton Road, Ilford, Essex IG1 2UQ

This game is like a cross between the sliding block puzzles we used

to keep in our pockets and jigsaws with straight edged pieces!

The aim is to reconstruct a picture from the jumbled pieces. There are three programs in the pack and four pictures in each program, so there is a good gradual difficulty gradient. Each puzzle can also be played in set numbers of moves and against the clock.

## White Knight Mk.II 32K BBC £11.50

BBC Software, 35 Marylebone High Street, London W1M 4AA

Is another chess program really necessary? The answer for White Knight is an unequivocal yes — I think it will soon become the program by which all others are judged.

No less than 16 different options are available to allow you to select speed and playing features. Tournament rules can be set up, as can clock time, orientation (black or white), and difficulty (i.e. how long the computer will 'think').

Speed of 'thought' can actually be set from between 1 second and several hours.

If all these options are not enough, White Knight also dis-

plays details of its thought processes, giving insight into strategy.

In my opinion, the program played an interesting and challenging game — so challenging that I decided to let it play against Sargon II running on my Apple II.

Most impressively, White Knight beat level I Sargon, playing white, after 60 moves. Perhaps I'll let it play itself with invisible pieces (more options!).

P.D.

instructions	90%
ease of use	90%
playability	99%
value for money	80%



## It's Only Rock 'n Roll 48K Spectrum £6.95

K'Tel, 620 Western Avenue, London W3

Already a big name in selling records and gadgets, K-Tel is now jumping on to the software bandwagon.

But this is a bad start — and anyone joining a sophisticated market needs to make a strong opening bid.

The challenge to become a star lost attraction after one or two plays. For a program based on pop music a machine with synthesiser ability is needed, say BBC or Commodore.

The Spectrum cannot do much to provide sound in the concert highlights graphics sequence, which is a waste of time and

memory.

You must take decisions regarding song writing, management, concert tours, energy and cash expenditure.

You are swung between the options list, the consequences of your decision and odd news-flashes, which often appear to be of no consequence to your situation.

Can you make a million and collect three status symbols?

One of the least amusing

features is the attempted humour in the random composition of song lyrics — lavatory style laughs.

If you are intent on making a million then don't invest your first £7 in this. P.C.

instructions	50%
playability	20%
graphics	10%
value for money	10%



# Sport with thought

## Our review panel tries out a selection of thinking and strategy games to play on your micro

If you decide to play against the clock, then a slow move means that a random exchange is made. This can undo some of your previous good work and makes the program that much more interesting.

Beyond that there is very little to say. It works well enough and the pictures are acceptable but not thrilling.

If mental geometry is your thing, then it might be for you —

otherwise, buy a jigsaw. D.C.

instructions	60%
ease of use	70%
graphics	70%
value for money	50%



## Gangsters! 48K Spectrum £6

Cases Computer Simulations, 14 Langton Way, London SE3 7TL

I have seen quite a few version of Kingdoms in my time, but Gangsters has to be my favourite. The first time I played it only took me 11 months to take over the underworld. Great.

The idea of the game is that you are the leader of a new gang in town and with the capital you are given at the start of the game you must take over, and eventually become master of the underworld.

You can buy such appealing things as speakeasies, brothels and distilleries. With these establishments you make your income. This can then be either used to

buy more speakeasies etc. or used as bribes and payments for contracts.

The game uses excellent sound and graphics throughout, especially for a game which is not normally associated with all the whizzes and bangs you would find in an arcade game.

For example, it starts with the screen being shot with bullet holes, accompanied by some pretty effective, and obviously machine code, sound.

The game itself is written in BASIC, but it runs perfectly well. I have only found one bug so far — if you enter the amount of gangsters you want to hire as zero (which it accepts), then the game gets caught in endless loops. P.S.

instructions	85%
playability	100%
graphics	90%
value for money	99%



# All that's new at the Microfair

Once again, we bring you the first full report of the latest ZX Microfair. Paul Liprot went there



Denis Thatcher dreams of some of the characters in the new adventure *Denis Through the Drinking Glass*



Chris Monckton, proprietor of Chipmunk, claims you'll clean up at the casino with his Blackjack program



A new computer trolley from Young and Jones keeps all your computing gear tidy



Anne Galloway, 23, with the latest game from Lydenhurst, *De-Fusion*



Leslie Hartridge, "whizz-dad" and author of *Flippit*, with daughters Mary-Ann and Carol-Lynn

IT WAS a more relaxed Microfair this time because organiser Mike Johnston had extended it to two days.

So, although more than 11,000 people attended there was room to move in the aisles — unlike last time when 8,000 attended the one-day event.

It was held at north London's Alexandra Pavilion, which will also be the venue for the next Microfair on February 4.

There was lots of new software and a selection of new additions... plus more retailers than at earlier shows.

This last fact prompted software house CRL to abandon its booked stand.

Managing director Clement Chambers said there was no point in staying when retailers were selling the same software as the manufacturers and, in some cases, undercutting prices.

But Mr Johnston, who is also secretary of the Guild of Software Houses, said he was not going to dictate who took stands, provided the shows offered the widest possible selection of additions and software.

In fact, he said, retailers could extend the range of software on show by displaying products from companies without stands.

"I would have liked him to have stayed since he booked and some people will have been disappointed. And if he can't undercut retailers..."

A lovable but dim St Bernard called Brandy was the inspiration for the first arcade game from **Carnell**, the software company best known for its adventures.

The Adventures of St Bernard, priced at £5.95 for the Spectrum, is based on director Stuart Galloway's dog. He said: "Brandy gave me the idea. He's as thick as two short planks."

In the game, programmed by Stephen Kirk, you guide Brandy past wolves, pools with ravenous walrus and skating penguins to rescue his mistress from the lair of the evil snowman.

Carnell also launched *The Crypt* (£4.95, Spectrum) by co-director Roy Carnell, who wrote most of Carnell's other adventures. Two more which continue the theme are due next month.

*Denis Through the Looking Glass*, a Spectrum adventure at £5.50, bears the warning: "Not recommended for children under 13."

It is based on our Prime Minister's husband and features figures like Ken Livingstone, Norman Tebbit, Mary Whitehouse, Tony Benn and the Pope with Dennis Skinner, voluble MP for Bolsover, as the guide.

**Applications** Roger Taylor explained: "There are a couple of

bawdy bits when he gets to Soho. But you will never lose it if you've got a dirty mind."

**PSL** showed a new light pen from Trojan designer Geoff Jones. Priced at £17.25 for the Spectrum, it can draw in hi-res with a choice of eight colours and screens can be saved from and loaded to the screen.

The company also had a new *AbbeX* game by 17-year-old Paul Reynolds. *Krakatoa* (£5.95, Spectrum) is part arcade, part strategy in which you have to stop a tanker being sunk. If you fail you must rescue survivors by helicopter.

**Hisoft** brought out *Microdrive* versions of *Pascal* (£25) and *Devpac* (£14), an assembler/disassembler. More comprehensive versions are promised next month and Hisoft says existing owners can upgrade at a small cost.

**CDS** has two new £5.95 games for the Spectrum: *Magic Meanies*, an arcade game which takes place underground, and *Spectrum Safari*, in which three men stranded on an island have to barter for food and boat.

The **YOJO** computer desk trolley was on display by **Young and Jones Designs**. Priced at £44.95 — with £4.95 for optional storage bin — it is supplied packed flat in beige and black painted steel. It holds computer, tape unit, TV, disc drives with power supply and cables kept out of sight.

**David Husband's ZX81 FORTH ROM** with multi-tasking replaces the ZX81's BASIC ROM and comes as a fit-it-yourself EPROM, with manual, at £25. It needs memory expansion and will work with 16K, 32K or 64K RAM packs.

Mr Husband says his **FORTH** is quicker than **FIG-FORTH** in most applications, being a compiler directive language which does not use the traditional inner-interpretive approach.

ZX81 **FORTH** matched **FIG-FORTH** standards, but not all **FIG-FORTH** words due to lack of memory. It contained some non-standard words for multi-tasking — up to 10 at a time which can be scheduled to execute from 50 times a second to once a year.

Ready converted ZX81s are available.

**Mikro-Gen** launched 13 new titles, bring its range up to 25. Among them is *Mad Martha II*, a sequel to its top-seller featuring a hen-pecked husband. **Mikro-Gen's** Paul Denial said Pat the Postman, which involves collecting parcels for a mail train, was good for children because "no-one kills anything."

Both cost £6.95.

A partnership of three teenagers, calling themselves **Star-**

## SHOW REPORT

zone, showed their first product, an arcade game with the familiar-sounding name of Zaxxon (Spectrum, £5.50). But writer Nial Mardon, 15, said: "It's not the same as Zaxxon." The partnership, Tim Mardon (Nial's brother), David Cowell and Tim Lake, plan more software for the Spectrum and the BBC micro.

**Add-On Electronics** showed two new £5 Spectrum games: Chuckman, a maze game featuring bombs and pits, and a space fighter game called 3D Star Wars.

Master Tool Kit (£9.95) from OCP, adds new features to the Spectrum, including auto- and re-number, trace, clock and alarm, delete/copy, string search and substitute, 10 user defined keys and a separate character generator.

Nineteen new games were brought out by **dk Tronics** — 12 for the Spectrum, five for the Commodore 64 and two for the VIC-20.

**Quicksilver** has Ultisynth 64, which turns the Commodore 64 into a music synthesiser for £14.95 and a version of its popular Mined Out for the Electron (£6.95).

New concepts in Spectrum joysticks, both costing £9.95, were shown by two separate companies — on adjoining stands. Both joysticks clamp onto the keyboard and depress the cursor keys and are produced by E.E.C. and **Grant Design**.

**Artic** had Earth Defence, in which you save a city from nuclear devastation, and the self-explanatory Snooker, both at £5.95 for the Spectrum.

The company also previewed a ladders game called Bear Bover in which your Teddy bear has to avoid the bover bears. Due out in a fortnight, it was written by 27-year-old Jon Ritman.

**Gilsoft** promised four new adventures next month, all written with its program called The Quill, which enables machine code adventures to be written without a knowledge of machine code.

A new joystick interface from **Fox Electronics** (£28.50) contains a CMOS RAM, powered by a trickle-charge battery, which can store the names of 16 games and the keyboard details for up to three months. It can also be used as a pseudo-ROM for regularly-used routines. The plug-in interface accepts Atari-type nine-pin joysticks.

**Silversoft** showed three new arcade games at £5.95 — Freez' Begg, Robot Riot and Sam Spade.

De-Fusion (£5.50, Spectrum) from **Lydenhurst** involves you in defusing a bomb, while avoiding skinheads' boots...

Dressed as Groucho Marx,

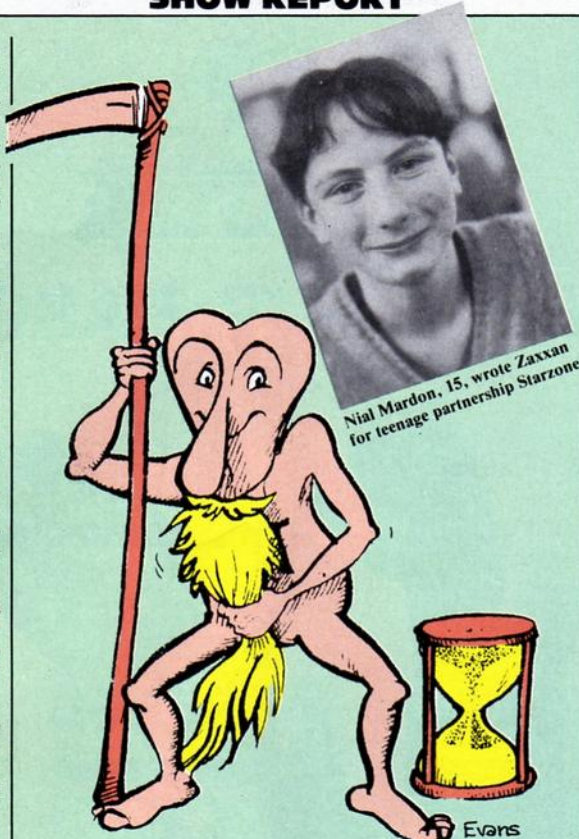

The Piman, Automata's character, is on a calendar, audio tape — and computer programs

director Mel Croucher lived up to Automata's image as software's jokers.

He was offering a Christmas deal which wasn't software at all. The £5 package consists of a C20 blank tape, a calendar featuring Automata's Piman character plus an audio tape of The Piman's Greatest Hits.

Recorded by Mel Croucher, the tracks include Computer Alphabet ("by Lurch, the office parrot"), Country Musac ("by Lady Clair Sincive and the Bad Tastes") and the extended disco version of Pimania ("as recommended by leading South American torturers). Sound effects include a Sherman tank and Concorde.

New software from Automata includes Morris Meets the Bikers (£6, Spectrum) based on the Piman character's car and with a song called Leader of the Pac on the same tape; and Yahtzee (£5) which has Dragon and Spectrum versions on the same cassette.

**Fantasy** and **Vortex** launched sequels to earlier successes.

Doomsday Castle (£6.50, Spectrum) is an arcade-adventure which follows Fantasy's Pyramid.

And Android 2 (Spectrum, £5.95) is the follow-up by Vortex of Android 1.

Educational specialists **Widgit** brought out a three-program tape designed to help children of five-10 with logic and reasoning. Priced at £6.25 for the Spectrum, The Humpty Dumpty Mystery and Who Killed Cock Robin? was written by primary school deputy head Gordon Askew.

Leslie Hartridge, author of Flippit (Spectrum, £9.95) and proprietor of **Lez Peranto**, brought along daughters Mary-Ann, 17, and 14-year-old Carol-Lynn to help out on the stand. Mary-Ann had helped father in the early stages by typing in his listings.

Commenting on his age, Mr Hartridge, a 59-year-old teacher, said: "With all the whizz-kids around, why shouldn't there be some whizz-dads?"

Wargames **Red Shift** showed a pre-production version of Nebula (£6.95, Spectrum) a strategy game of space conquest.

BJ (£5.95, Spectrum) will help you win at Blackjack when you play with real cards, claims author Chris Monckton, proprietor of **Chipmunk**. Mr

Monckton, who developed the program on an Osborne 1, said you learn as you watch the computer play. To bring some style to his stand, he was dressed in a dinner jacket...

**Richard Shepherd**, adventure specialists, showed its latest, Urban Upstart (£6.50, Spectrum), set in a town called Scarthorpe — "a town so tough even the dogs carry flick-knives."

**Premier** showed the first in a series of six tapes written by primary school teachers to encourage creative writing. Spacewreck (Spectrum, £4.50), generates an adventure after a space crash — selecting incidents at random. Premier offers a marking and assessment service of written work for £1.50 per program.

### Where to find them

Exhibitors in order of appearance in article:

**Carnell**, North Weylands Industrial Estate, Molesey Rd, Hersham, Surrey

**PSL**, 52 Limbury Rd, Luton, Beds LU3 2PL

**Hisoft**, 13 Gooseacre, Cheddington, Leighton Buzzard, Beds LU7 0SR

**CDS**, 10 Westfield Cl, Tickhill, Doncaster, S Yorks DN11 9LA

**Young & Jones**, 10 Oak Rd, Clansfield, Portsmouth PO8 0LJ

**David Husband**, 2 Gorleston Rd, Branksome, Poole BH12 1NW

**Mikro-Gen**, 1 Devonshire Cott, London Rd, Bracknell, Berks

**Starzone**, 74 Wallingfor Rd, Shillingford, Oxford

**Add-On Electronics**, Units 2-4, Shire Hall Industrial Est, Saffron Walden, Essex

**OCP**, 4A High St, Chalfont St Peter, Bucks SL9 9OB

**dk Tronics**, Unit 6, Shire Hill Industrial Est, Saffron Walden, Essex CB11 3AQ

**Quicksilver**, 13 Palmerton Rd, Southampton SO1 1LL

**E.E.C.**, 1 Whitehouse Cl, Chalfont St Peter, Bucks SL9 0DA

**Grant Design**, Bank House, Reepham, Norwich, Norfolk NR10 4JJ

**Artic**, Main St, Brandesburton, Driffield YO25 8RL

**Gilsoft**, 30 Hawthorn Rd, Barry, S Glamorgan, S Wales

**Fox Electronics**, 141 Abbey Rd, Basingstoke, Hants

**Silversoft**, 271/273 King St, London W6

**Lydenhurst**, 38 Ashley Rd, London N19

**Automata**, 27 Highfield Rd, Portsmouth PO4 9DA

**Fantasy**, Falconberg Lodge, 27A St Georges Rd, Cheltenham, Gloucs

**Vortex**, 280 Brookside Rd, Brooklands, Manchester M23 9HD

**Widgit**, 48 Durham Rd, London N2 9DT

**Lez Peranto**, distributed by Sinclair Research, Camberley, Surrey GU15 3BR

**Red Shift**, 12C Manor Rd, Stoke Newington, London N16 3SA

**Chipmunk**, 52A The Vale, London NW11

**Richard Shepherd**, Elm House, 23/25 Elmshott La, Slough, Berks

**Premier**, 1 Hollington Rd, Upper Team, Stoke on Trent ST10 4LG



**ASP SOFTWARE**

A MEMBER OF THE ARGUS PRESS SOFTWARE GROUP

**A STEP BEYOND THE ARCADE...**



Demon Knight · The Valley · Strategy 1—Invasion · Strategy 2—Bismark  
White Barrows · Detective · Cells & Serpents · Stockmarket  
Conquering Everest · Cloneit/Renumber · Gallery of Death · Planetfall

*FOR MOST POPULAR MICROS*



# ASP SOFTWARE

Now available from:

Amersham Computers  
18 Woodside Road  
Amersham  
Bucks

John W Bagnall Ltd  
18 Salter Street  
Stafford ST16 2JU

Brainwave Micros Ltd  
24 Crown Street  
Ipswich  
Suffolk IP1 2LD

Cannock Computer Systems Ltd  
18 Old Penkridge Road  
Cannock  
Staffs WS 1MZ

Canterbury Software Centre  
9 The Friars  
Canterbury  
Kent CT1 2AS

The Car Shop  
103 Lickhill Road  
Stourport

CB TV Hi-Fi & Video  
Sales & Service  
59 Tamworth Street  
Lichfield  
Staffs

Channel 8 Software Ltd  
51 Fishergate  
Preston  
Lancs

Computer Cabin  
24 The Parade  
Silverdale  
Newcastle  
Staffs

Computer Plus  
2 Church Lane  
Banbury  
Oxon

Philip Copley Hi-Fi Ltd  
6 Wisley Street  
Clifford Court  
Ossett  
Wakefield  
N Yorks

D A Computers Ltd  
104 London Road  
Leicester LE2 0Q2

Dimension  
27/29 High Street  
Leicester

Eddy's (Nottm) Ltd  
ENL Audio Visual  
116/118 Afreton Rd  
Nottingham NG7 3NR

Estuary Software Products  
261 Victoria Avenue  
Southend on Sea  
Essex

Fabulous Phones  
72 High Street  
Orpington  
Kent

Fal Soft Computers  
8 St Georges Arcade  
Falmouth  
Cornwall TR11 3DH

Gemini Electronics  
50 Newton Street  
Manchester

Godfreys  
30 East Walk  
Basildon  
Essex

JCV Organisation Ltd  
Units 7/8  
Wharf Street  
Warwick CV34 5FO

KP Camera & Computer Shop  
12a Kings Parade  
Cambridge

Mega Ltd  
7 Anley Street  
St Helier  
Jersey

Micro Business Centre Ltd  
17-19 Lichfield Street  
Wolverhampton WV1 1EA

Micro North  
7 Broad Street  
Bury  
Lancs

Selectronics  
392 Farnham Road  
Slough  
Berks SL2 1JD

Sherwoods Photographic Ltd  
11-13 Gt Western Arcade  
Birmingham B2 5HU

Software Centre  
128 Wigmore Street  
London W1

Software City  
3 Lichfield Passage  
Wolverhampton  
W Midlands

Statacom Ltd  
234 High Street  
Sutton  
Surrey

Telford Electronics  
Inside Bammers  
Telford Town Centre  
Shropshire

Trend Hi-Fi & Video  
167 High Street  
Walthamstow  
London E17 9PD

Vision Store  
96/98 North End  
Croydon CRO 1UD

Whimz  
36 Battersea Rise  
London SW11

D T Wicks  
49 North Station Road  
Colchester  
Essex

William Smith (Booksellers) Ltd  
University Bookshop  
White Knights  
Reading RG6 2AH

Windsor Computer Centre  
Thames Avenue  
Windsor  
Berks

3D Computers Ltd  
230 Tolmouth Rise South  
Surbiton  
Surrey

4-Mat Computing  
67 Friargate  
Preston  
Lancs

## TELEPLUS

## 'POPULAR'



★ Sturdy all metal frame in Matt Black or Cream ★ 27 1/2" wide, enough to accommodate the largest home computer with tape or disc drive side by side ★ Choice of three veneers - Black, Pine or Dark Oak ★ Elevated T.V. shelf strong enough to carry even a 26" screen model ★ Side mounted attachment for holding manual or magazine ★ On castors for easy movement ★ A modern piece of furniture for Home or Office ★ Overall size: 36H x 28D x 27 1/2W.

£49.95 inc. of Postage and Packaging

### TELEPLUS 'COMPANION'

All metal frame in Matt Black ★ Inclined veneered top ★ Use on floor or whilst in the comfort of your easy chair ★ Overall size ●H x ●D x ●W.

£18.95 inc. of Postage and Packaging.

BOTH SUPPLIED IN FLAT PACK

TRADE ENQUIRIES WELCOME.

	QTY	Frame	Veneer
Teleplus 'Popular'	<input type="checkbox"/>	Black <input type="checkbox"/>	Black (Ebony) <input type="checkbox"/>
Teleplus 'Companion'	<input type="checkbox"/>	Cream <input type="checkbox"/>	Pine <input type="checkbox"/>
			Dark Oak <input type="checkbox"/>

NAME .....

ADDRESS .....

..... TEL. No: .....

Enclose Cheque/PO payable to TELEPLUS LTD. and send to:

TELEPLUS LTD.

Hawthorns, New Spole Road, Swaffham, Norfolk.

Telephone orders: SWAFFHAM (0760) 24394

PLEASE ALLOW UP TO 28 DAYS FOR DELIVERY.

## Experience CDS programs yourself

This is 'Spectrum Safari' a brand new Adventure game from CDS.

Just one of a new range of exciting programs....  
Arcade action...  
3D Space adventures  
Education and pure fantasy...



ONLY £5.95 each at

W.H. Smiths, 'Boots,

John Menzies and other

leading Computer Stores, or...



Available direct from CDS Micro Systems  
10, Westfield Close, Tickhill, Doncaster DN11 9LA.  
Send Cheque or P.O. To CDS

Tel: (0302) 744129.

\* Selected titles only

ARGUS PRESS SOFTWARE LTD.

145 Charing Cross Rd, London WC2H 0EE

Tel: 01-437 1002



# Unlock Your Imagination

## SCOPE

Computer Graphics Language

- ★ A VERY POWERFUL, TRUE MULTITASK LANGUAGE
- ★ AS FAST AS MACHINE CODE
- ★ SIMPLER THAN BASIC

Write Machine Code in a fraction of the time currently required

SCOPE is available from most good quality dealers and selected branches of

**WHSMITH**

For details of how to get your games published commercially contact ISP Marketing

### TECHNICAL DETAILS

SCOPE is a fully structured multitask language specifically for writing *graphics*, *animation* and *sound*. Being fully compatible with BASIC it is ideal for writing both arcade and adventure style games. Additionally, with SCOPE present in high memory it can be used as an assembler with SCOPE words as plain language mnemonics. Therefore no knowledge of machine code is required. The language is extremely easy to comprehend and is very powerful indeed providing many features not available from BASIC.

**SCOPE HAS TO BE USED TO BE BELIEVED**

**48K SPECTRUM**



CLIP THE COUPON NOW AND UNLOCK YOUR IMAGINATION  
Post to: ISP Marketing Ltd, Crown House, 588 High Street, Coburne, Surrey  
Tel: Coburne (04889) 74151. Please rush me ..... copies of the SCOPE computer  
graphics language tape and instruction manual at £11.95 (a&p free).  
(Cheques payable to: ISP Marketing Ltd)

Name

Address

Block capitals please  
Dealer Enquiries  
Welcome

PRICE  
**£11.95**



## Top Ten programs for the Spectrum

- |    |                   |                |
|----|-------------------|----------------|
| 1  | Chequered Flag    | Psion (4)      |
| 2  | Atic Atac         | Ultimate (7)   |
| 3  | The Pyramid       | Fantasy (-)    |
| 4  | Ant Attack        | Quicksilva (3) |
| 5  | Kong              | Ocean (2)      |
| 6  | Lunar Jetman      | Ultimate (1)   |
| 7  | Manic Miner       | Bug Byte (5)   |
| 8  | Splat             | Incentive (10) |
| 9  | Flight Simulation | Psion (8)      |
| 10 | Scrabble          | Psion (-)      |

Compiled by W.H.Smith. Figures in brackets are last week's positions

## Top Ten programs for the ZX81

- |    |                 |                |
|----|-----------------|----------------|
| 1  | Defender        | Quicksilva (6) |
| 2  | Scramble        | Quicksilva (1) |
| 3  | Asteroids       | Quicksilva (7) |
| 4  | Chess           | Sinclair (5)   |
| 5  | Space Raiders   | Sinclair (9)   |
| 6  | Fantasy Games   | Sinclair (8)   |
| 7  | Invaders        | Quicksilva (-) |
| 8  | Inca Curse      | Sinclair (-)   |
| 9  | ZX81 Forth      | Sinclair (-)   |
| 10 | Maths/Geography | Sinclair (-)   |

Compiled by Websters. Figures in brackets are last week's positions

## Top Ten programs for the Dragon

- |    |                    |                |
|----|--------------------|----------------|
| 1  | Mined Out          | Quicksilva (3) |
| 2  | Pettigrews Diary   | Shards (10)    |
| 3  | Night Flight       | Salamander (-) |
| 4  | Ring of Darkness   | Wintersoft (1) |
| 5  | Dragonfly II       | Hewson (-)     |
| 6  | Gridrunner         | Salamander (-) |
| 7  | Champions          | Peaksoft (5)   |
| 8  | Lionheart          | Peaksoft (-)   |
| 9  | Frogger            | Microdeal (6)  |
| 10 | Morocco Grand Prix | Microdeal (-)  |

Compiled by Websters. Figures in brackets are last week's positions

## Top Ten programs for the VIC-20

- |    |                       |                     |
|----|-----------------------|---------------------|
| 1  | Arcadia               | Imagine (4)         |
| 2  | Wizard & the Princess | Melbourne House (1) |
| 3  | Wacky Waiters         | Imagine (2)         |
| 4  | Laser Zone            | Llamasoft (-)       |
| 5  | Matrix                | Llamasoft (10)      |
| 6  | Gridrunner            | Llamasoft (-)       |
| 7  | Skyhawk               | Quicksilva (5)      |
| 8  | Sargon II             | Commodore (-)       |
| 9  | Money Manager         | Commodore (-)       |
| 10 | Panic                 | Bug Byte (3)        |

Compiled by Websters. Figures in brackets are last week's positions

## BEST SELLERS

## Top 30

- |    |                          |               |               |
|----|--------------------------|---------------|---------------|
| 1  | Atic Atac                | Ultimate      | Spectrum (-)  |
| 2  | Lunar Jetman             | Ultimate      | Spectrum (7)  |
| 3  | Kong                     | Ocean         | Spectrum (5)  |
| 4  | Jetpac                   | Ultimate      | Spectrum (2)  |
| 5  | Manic Miner              | Bug Byte      | Spectrum (3)  |
| 6  | The Hobbit               | M.House       | Spectrum (4)  |
| 7  | Valhalla                 | Legend        | Spectrum (1)  |
| 9  | Chuckie Egg              | A&F           | Spectrum (17) |
| 10 | 747 Flight Simulator     | Doctorsoft    | BBC           |
| 11 | Pool                     | CDS           | Spectrum (16) |
| 12 | Melbourne Draw           | M.House       | Spectrum (-)  |
| 13 | Falcon Patrol            | Virgin        | CBM 64 (25)   |
| 14 | Ostron                   | Softtek       | Spectrum (-)  |
| 15 | Night Flight             | Microdeal     | Dragon (-)    |
| 16 | Killer Gorilla           | Program Power | BBC (10)      |
| 17 | Trans-Am                 | Ultimate      | Spectrum (8)  |
| 18 | Splat                    | Incentive     | Spectrum (-)  |
| 19 | Cookie                   | Ultimate      | Spectrum (9)  |
| 20 | Horace and the Spiders   | Psion         | Spectrum (13) |
| 21 | The King                 | Microdeal     | Dragon (18)   |
| 22 | Penetrator               | M.House       | Spectrum (22) |
| 23 | Hall of the Things       | Crystal       | Spectrum (14) |
| 24 | Cuthbert in the Jungle   | Microdeal     | Dragon (15)   |
| 25 | Snooker                  | Arctic        | Spectrum (-)  |
| 26 | Franklins Tomb           | Salamander    | Dragon (-)    |
| 27 | 3D Dimension Destruction | Arctic        | Spectrum (-)  |
| 28 | Crazy Painter            | Microdeal     | Dragon (-)    |
| 29 | Pssst                    | Ultimate      | Spectrum (20) |
| 30 | 3D Combat Zone           | Arctic        | Spectrum (23) |

Compiled by PCS Distribution (0254 691211) and sanctioned by the Computer Trade Association. Chart is for retail sales in individual outlets in the UK and Northern Ireland for the fortnight ended December 4

## Top Ten programs for the Commodore 64

- |    |                 |                  |
|----|-----------------|------------------|
| 1  | Crazy Kong      | Interceptor (8)  |
| 2  | Frogger         | Interceptor (1)  |
| 3  | Laser Zone      | Llamasoft (-)    |
| 4  | Spritman        | Interceptor (10) |
| 5  | Motormania      | Audiogenic (6)   |
| 6  | Purple Turtles  | Quicksilva (2)   |
| 7  | Quintic Warrior | Quicksilva (4)   |
| 8  | Aquaplane       | Quicksilva (9)   |
| 9  | Renaissance     | Audiogenic (-)   |
| 10 | Caesar the Cat  | Mirrorsoft (-)   |

Compiled by Websters. Figures in brackets are last week's positions

# "ADVENTURES INTO IMAGINATION"

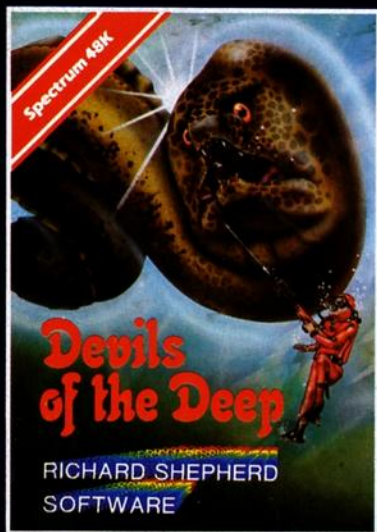

### Devils of the Deep

Discover the secrets of Atlantis as you wander amongst its ancient columns. Explore the 100 deadly sectors of its treacherous seabed! Beware of giant eels! £6.50



### Super Spy

Follow the trail of Dr. Death through complex puzzles, coded messages and 3-D mazes until you find his lair! But beware — even with your death-defying gadgets you may not live to tell the tale! £6.50

**CREDIT CARD HOTLINE**  
**06286 63531 (24 HOURS)**



Selected titles available from  
**W. H. SMITH, BOOTS, MENZIES**  
**AND ALL LEADING COMPUTER STORES**

# RICHARD SHEPHERD SOFTWARE

ELM HOUSE, 23-25 ELMSHOT LANE, CIPPENHAM, SLOUGH, BERKSHIRE.

"ADVENTURES INTO IMAGINATION"  
"ADVENTURES INTO IMAGINATION"

# "ADVENTURES INTO IMAGINATION"

Selected titles available from  
**W. H. SMITH, BOOTS, MENZIES  
AND ALL LEADING COMPUTER STORES**

**Spectrum 48K**

## Invincible Island

by Peter Cooke

Exhaust your ingenuity in the quest to find The Seven Parchments of Xaro and their meaning! Will they lead you to undreamt of treasures or eternal doom? Explore the mysteries of the stockade and puzzle within the Pagoda! A spectacular split screen graphic and text adventure to braintease you for weeks!

Adventurous graphics for every location.  
Save routine. £6.50

**RICHARD SHEPHERD  
SOFTWARE**

**Spectrum 48K  
Commodore 64**

## Ship of the Line

**RICHARD SHEPHERD  
SOFTWARE**

**Ship of the Line**  
Command a sailing ship, juggle your supplies, crew and firepower. Fearlessly battle your way up the admiralty ladder, bribe Sea Lords as necessary until you make First Sea Lord! £6.50

**Spectrum 48K  
Commodore 64**

## EVEREST ASCENT

**RICHARD SHEPHERD  
SOFTWARE**

**Everest Ascent**  
Conquer the world's highest peak in defiance of all the obstacles, man and nature can throw at you. Survive avalanches, cross bottomless crevasses, cope with wayward Sherpas — but don't run out of supplies! £6.50

**CREDIT CARD HOTLINE  
06286 63531 (24 HOURS)**

**RICHARD SHEPHERD  
SOFTWARE**

ELM HOUSE, 23-25 ELM SHOTT LANE, CIPPENHAM, SLOUGH, BERKSHIRE.

All programs are sold subject to the condition that they may not, by way of trade or otherwise, be lent, hired out, resold or otherwise circulated without the written permission of Richard Shepherd.

## TI-99/4A PROGRAM

# Don't let that alien land!

**How long can you keep off the marauding alien hordes who are trying to take over your laser base? You'll need a joystick to play Stephen Harris's Space Alien game for the unexpanded TI-99/4A**

The alien has landed — a scene from Xtro



What's this? Your scanner is telling you there's an alien landing craft approaching your base — and your experience tells you that it isn't planning a social visit.

You'd better move quickly to make sure that craft doesn't get control of the base. Use your joystick to move the base from side to side, and try to shoot the alien down with your missiles. But don't be too trigger happy, or you'll run out of missiles, and the game'll be over.

You get 10 points for each hit — and a new alien will start to make its way towards your base. How long can you fight them off?

### Main variables

**QW** keeps score  
**A** randomises alien position  
**F** recognises if missile button is pressed  
**UI** recognises if joystick is moved

### How it works

**100-240** print out instructions  
**250-390** define characters and colour  
**400-470** plot stars  
**480-660** move alien  
**670-730** move and fire  
**740-800** move left  
**810-870** move right  
**880-920** print laser  
**930-1060** out of missiles  
**1070-1160** print out score  
**1170-1290** end of game

### Hints on conversion

**CALL CLEAR** clears the screen  
**CALL HCHAR (A,P,G)** A = row, P = column, G = positions ASCII character  
**CALL SCREEN (X)** sets screen colour  
**CALL SOUND (N,V,G)** N = length of note, V = frequency, G = volume  
**CALL KEY (N,V,G)** N = console keyboard eg. call key (0,V,G). V = recognises if key is pressed. G = recognises if same key is pressed

```
100 REM SPACE ALIEN
110 REM BY STEPHEN HARRIS
120 REM 1983
130 CALL CLEAR
140 CALL SCREEN(2)
150 FOR ZX=2 TO 16
160 CALL COLOR(ZX,16,1)
170 REM INSTRUCTIONS
180 NEXT ZX
190 PRINT "SPACE ALIEN"::"YOU CO
NTROL THE BASE"::"AT THE BOTTOM
OF THE SCREEN"::"BY USING THE JO
YST STICK. "::
200 PRINT "SHOOT DOWN THE ALIEN
AND"::"PREVENT IT FROM LANDING B
Y"::"PRESSING THE FIRE BUTTON"::
210 PRINT "BUT BEWARE... YOU ONL
Y HAVE"::"A LIMITED AMOUNT OF MI
SSILES"::
220 PRINT "SCORING=10 POINTS PER
HIT"::"NOW PRESS ANY KEY "
230 CALL KEY(0,TYU,UYT)
240 IF (TYU=0)+(TYU=-1) THEN 230
250 CALL CLEAR
260 REM DEFINE CHARACTERS AND
SET UP SCREEN
270 CALL COLOR(14,12,1)
280 CALL CHAR(159,"181818181818
818")
290 CALL COLOR(16,16,1)
300 D=16
310 Z=2
320 CALL CHAR(139,"1CEE7DFD5FDFF
7D")
330 CALL HCHAR(24,1,139,32)
```

## TI-99/4A PROGRAM

```

340 CALL CHAR(42,"1818183C7EFFFF
5A")
350 CALL CHAR(127,"99C3A5FFE7423
C42")
360 CALL COLOR(2,7,1)
370 CALL COLOR(12,8,1)
380 CALL HCHAR(23,D,42)
390 CALL CHAR(149,"0000001000000
000")
400 REM PLOT STARS
410 FOR TU=1 TO 30
420 CALL COLOR(16,16,1)
430 KJ=INT(RND*32)+1
440 PI=INT(RND*24)+1
450 IF (PI=24)+(PI=23) THEN 440
460 CALL HCHAR(PI,KJ,149)
470 NEXT TU
480 REM MOVE ALIEN
490 A=INT(RND*30)
500 IF A>10 THEN 530 ELSE 510
510 A=2
520 GOTO 570
530 IF A>20 THEN 560 ELSE 540
540 A=16
550 GOTO 570
560 A=30
570 CALL HCHAR(Z,A,127)
580 CALL HCHAR(Z,A,32)
590 CALL SOUND(30,-1,0,110,0)
600 Z=Z+1
610 IF Z=23 THEN 620 ELSE 680
620 CALL HCHAR(23,D,127)
630 CALL SOUND(1000,-5,0,990,0)
640 PRINT "THE ALIEN HAS LANDED
ON YOUR BASE"
650 GOTO 1171
660 GOTO 680
670 REM MOVE AND FIRE
680 CALL KEY(1,F,6)
690 CALL COLOR(15,INT(RND*13)+3,
1)
700 IF (F=0)+(F=-1) THEN 710 ELSE
890
710 CALL JOYST(1,UI,AS)
720 IF UI=-4.0 THEN 750 ELSE 730
730 IF UI=4.0 THEN 820 ELSE 490
740 REM LEFT
750 CALL HCHAR(23,D,32)
760 D=D-14
770 IF D<2 THEN 780 ELSE 790
780 D=2
790 CALL HCHAR(23,D,42)
800 GOTO 490
810 REM RIGHT
820 CALL HCHAR(23,D,32)
830 D=D+14
840 IF D>30 THEN 850 ELSE 860

```

```

850 D=30
860 CALL HCHAR(23,D,42)
870 GOTO 490
880 REM PRINT LAZER

890 CALL VCHAR(2,D,159,21)
900 CALL SOUND(30,1000,0)
910 ER=ER+1
920 IF ER>4 THEN 940 ELSE 1030
930 REM OUT OF MISSILES
940 PRINT "YOU RAN OUT OF MISSIL
ES"
950 FOR A=-8 TO -5
960 B=B+110
970 C=10
980 CALL SOUND(500,A,0,B,C)
990 C=C-2
1000 NEXT A
1010 GOTO 1020
1020 GOTO 1171
1030 CALL VCHAR(2,D,32,21)
1040 IF D=A THEN 1080 ELSE 1050
1050 CALL SOUND(30,-7,0)
1060 GOTO 490
1070 REM PRINT OUT SCORE
1080 QW=QW+10
1090 CALL SOUND(100,-7,0)
1100 ER=0
1110 Q$="SCORE="&STR$(QW)
1120 FOR T=1 TO LEN(Q$)
1130 CALL HCHAR(1,T+1,ASC(SEG$(Q
$,T,1)))
1140 NEXT T
1150 Z=2
1151 CALL COLOR(12,INT(RND*14)+3
,1)
1160 GOTO 490
1170 REM END OF GAME
1171 IF QW>AW THEN 1172 ELSE 118
0
1172 AW=QW
1180 PRINT ":: YOUR SCORE IS ";Q
W::
1181 PRINT "HIGH SCORE=";AW
1190 PRINT "PRESS REDD OR BACK"
1200 CALL KEY(0,OI,ED)
1210 QW=0
1220 Z=2
1230 ER=0
1231 B=0
1240 IF (OI=15)+(OI=57) THEN 100
1250 IF (OI=6)+(OI=56) THEN 1270
1260 GOTO 1200
1270 CALL CLEAR
1280 PRINT "* *PRESS ANY KEY TO
BEGIN* *"
1290 GOTO 230

```

**COMPLETE PACKAGE  
FOR SPECTRUM  
OR BBC MICRO**



# Add on the printer that adds up to less than **£230**

A Seikosha GP100A Printer. Plus the correct interface\*, cable and software for either a Spectrum or BBC Micro. All at a price that adds up to just £229.95 inc. VAT.

For a superb combination of economy and reliability, this package is unbeatable.

### Full graphics capability

The Seikosha GP100A uses standard width paper, and prints in an 80 column dot matrix format. Printing speed is 50 characters a second (180 x 7 dots/sec).

The GP100A comes with a full graphics capability.

### Apply immediately

You can buy the Seikosha GP100A Printer at any of our dealers throughout the country. For the address of the one nearest you, phone this number without delay:

**0934 419914**

\*Centronics parallel interface is supplied as standard, unless serial RS232 is required for use with Sinclair Microdrive. Please specify.

**DRG**  
**BUSINESS**  
**MACHINES**

DRG Business Machines, Unit 13/14 Lynx Crescent, Winterstoke Road, Weston-super-Mare, BS24 9DN

Please send me further details of the Seikosha GP100A Printer, and the name of my nearest stockist.

I am particularly interested in Spectrum  BBC Micro

Name \_\_\_\_\_

Address \_\_\_\_\_

ASP

ASP SOFTWARE

A MEMBER OF THE ARGUS PRESS SOFTWARE GROUP

subjects you to...

# DEMON KNIGHT

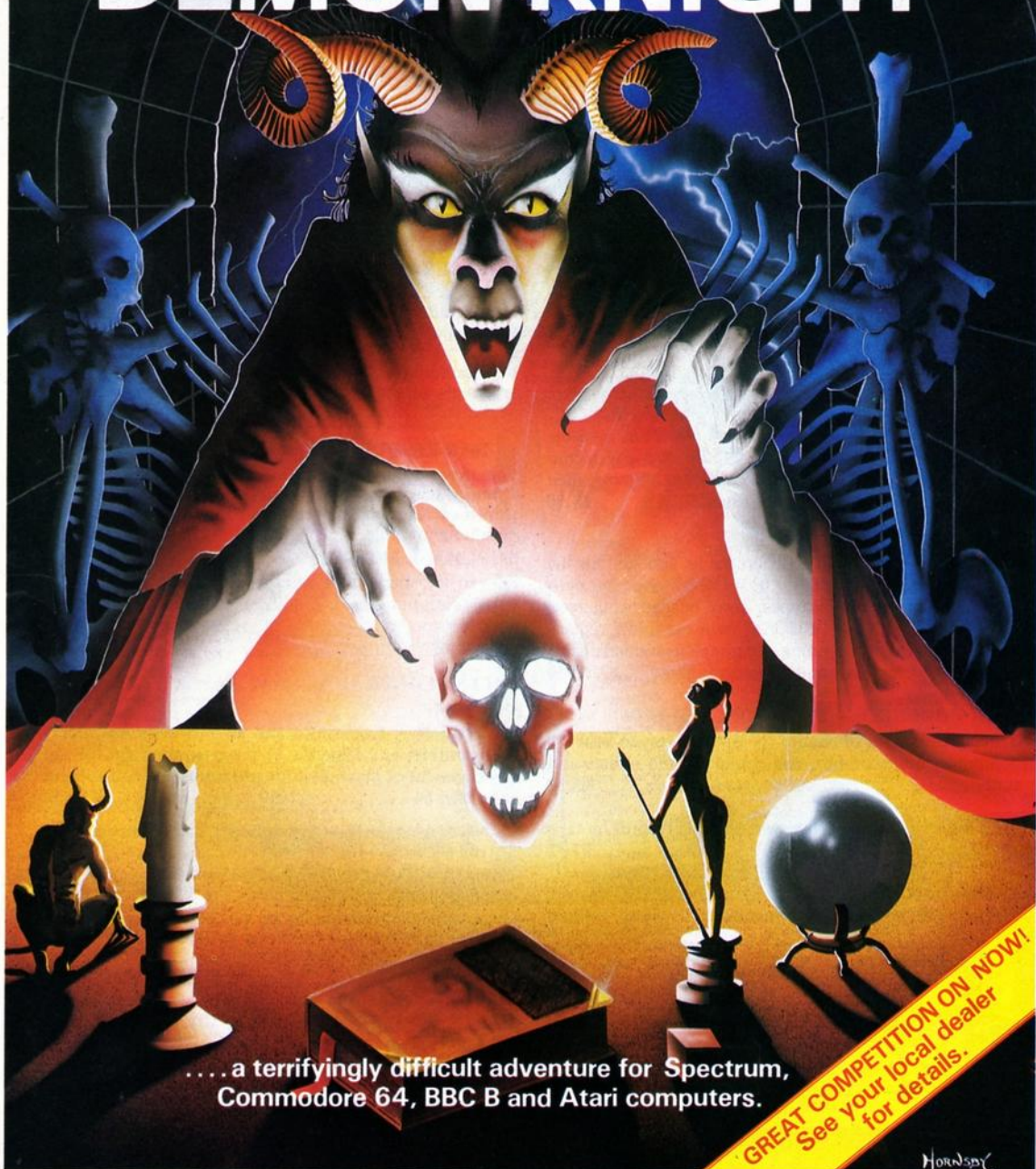

... a terrifyingly difficult adventure for Spectrum,  
Commodore 64, BBC B and Atari computers.

**GREAT COMPETITION ON NOW!**  
See your local dealer  
for details.

HORNBURY

# MR CHIP SOFTWARE

## SPECTRUM GAMES

### SPECTRUM DARTS (48K)

Five games of darts for 1-5 players, 501, Cricket, Killer, Round the board, Noughts and Crosses, four levels of play per game, take on the computer or friends at these games of skill and judgement. . . . . **£5.50**

### WHEELER DEALER

As for the Commodore 64, but now available for the 48K Spectrum, Texas TI99/4A and Dragon. . . . . **£5.50**

## VIC-20 GAMES AND UTILITIES

### JACKPOT

This is it, the ultimate Fruit Machine for the VIC with nudge, hold and respin 100% machine code. "Overall Jackpot is a beautifully written simulation giving superb graphics, animation and use of colour. In fact, this program makes Commodore's Fruit Machine cartridge look unbelievably cheap and nasty." Home Computing Weekly No. 20 19/7/83. . . . . **£5.50**

### KWAZY KWAKS

Accuracy and speed are required for this Shooting Gallery, superb use of colour and graphics in this new and challenging game from the author of Jackpot. 100% machine code, joystick or keyboard control. . . . . **£5.50**

### PACMANIA

Choose your own game from the following options — difficulty 1-3 speed 1-3, size of maze 1-3, visible or invisible maze, still or moving power pills, define your own key controls, any combination, if this is your type of game, then this is the one for you, for the 3K expand VIC. . . . . **£5.50**

### BUGSY (Joystick Only)

This is a Minefield with a difference as you step on the stones whilst collecting purple boxes which give you both time and points, they disappear from beneath your feet. DO NOT DESPAIR! "BUGSY" will randomly replace the stones but avoid bumping into him or its sudden death! An original compulsive and challenging game. . . . . **£5.50**

### MINI-ROULETTE — PONTOON — HI-LOW

Three great games of chance for the VIC, try to beat the computer, hours of fun, full colour, sound effects and tunes. . . . . **£5.50**

**DATABASE** — create your own files and records on tape. . . . . **£7.50**

**SUPER BANK MANAGER** — A full feature version any memory size, but needs 3K expansion. . . . . **£7.50**

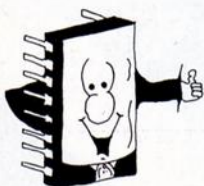

## COMMODORE 64 GAMES AND UTILITIES

### JACKPOT 64

At last its here, specially written for the 64, by the author of "JACKPOT" the ultimate Fruit Machine program for the VIC. . . . . **£5.50**  
(available from 1st Nov)

### WESTMINSTER

A game for up to four players, can you lead the party of your choice and win the general election, you tour the 60 constituencies (seats) buying votes, when you can, (just like the real thing), this must be one of the first board type games specially written for the computer. Why play on your own, have fun with your family and friends playing WESTMINSTER. . . . . **£5.50**

### RED ALERT

A game for 1-4 players, with sound and graphics. Make money in casinos, commit robbery, hide from the police, hire secret agents, (some of whom can be treacherous), negotiate for weapons, find and attack the secret rocket base to launch the missile, and watch the havoc and destruction caused. There's no turning back from "RED ALERT" . . . . . **£5.50**

### WHEELER DEALER

A game for two to twenty players, become a tycoon of the motor trade, you must obtain gearboxes, tyres and engines to produce cars for sale. Form syndicates, buy and exchange parts, buy dealerships, but be careful, you may become bankrupt and have to liquidate, find out what you are made of, have you got what it takes to become a WHEELER DEALER. . . . . **£5.50**

### LUNAR RESCUE

Our new version, avoid the asteroid belt, to rescue the stranded scientists, then fight your way back to the mother ship, fast reactions are required to safely land and dock your lunar module. . . . . **£5.50**

### PURCHASE LEDGER

Easy to use, single entry, handles 400 invoices per month, Gross/Nett purchases, V.A.T. . . . . **£14.50**  
Disk Version . . . . . **£17.00**  
(available from 1st Nov)

**SALES LEDGER** — As Above . . . . . **£14.50**  
Disk Version . . . . . **£17.00**

**CHIPMON** — Contains a one- or two- pass Assembler, Disassembler and Monitor. A programming aid for the development of machine code programs and routines on the CBM 64 . . . . . **£12.50**

**BANK MANAGER** — As our Super Bank Manager, but for the 64. . . . . **£7.50**  
Now available on disc with added facilities. . . . . **£10.00**  
Full documentation with all utility programs.

Other software available for the VIC and Commodore 64, send for free brochure, including RABBIT SOFTWARE at **£5.50 each**. Send Cheques/PO's to:

## MR CHIP SOFTWARE

Dept HCW, 1 NEVILLE PLACE, LLANDUDNO, GWYNEDD LL30 3BL.  
Tel: 0492 49747

Wanted: High quality software, of all types, for export and UK distribution.  
All programs now available on disc please allow £2.50 extra.

DEALER ENQUIRIES WELCOME



# Plug in and go places

You can find yourself in some very funny places when you set out on a computer adventure. Before you go, read all about them in our reviewers' reports

## 2003 - A Space Oddity 48K Spectrum £4.95

dk'Tronics, Unit 6, Shire Hill Industrial Estate, Saffron Walden, Essex

Mark well the name of this program because it certainly is an oddity.

Set in outer space, you have to find your way back to earth via a series of adventures which seem to have no point.

There are three possible exits to any scene, choosing from either north, south, east, west, up or down. These exits can be either a door, space ship, space warp, ladder, or space shield.

At some of the exits there are challenges to be met with a choice of fighting with either a laser or your mind. Of course, if you want

to be chicken, then you can run.

Treasure is lying about in various locations, and you either have to fight to get it, or it's there for the taking. All the exits are drawn for you, and there is one option I'm sure that you will take.

Drawing the time or space warp, takes up quite a bit of time, and pressing G will ensure that they are drawn no more.

I have a feeling that the title was

written tongue in cheek, and the game too. It makes for light relief in the serious world of space blasters and hyper-drives. **B.B.**

instructions	100%
playability	75%
graphics	60%
value for money	100%



## The Island 48K Spectrum £5.95

Virgin Games, 61-63 Portobello Road, London W11 3DD

An adventure game with two differences from Virgin! Not for them a complex manual; part of the fun is find out what the computer understands. And, yes, this is a graphic adventure, but very different from the Hobbit.

The adventure is set on some islands. Given the treasure map, you must navigate to the correct island, find the treasure and return with it.

When you start your adventure, this appears to be an all-text program. If, however, you manage to penetrate the fog bank en-route to the treasure island, you suddenly find yourself in the midst of a "dodge the rocks"

action sequence much like an arcade game.

Fail, and you are sunk — sink, and you fail. Successful navigators reach the Island, but beware the swamp! More action sequences follow.

There is, however, a criticism. In the original text adventures, like Adventure I from Abersoft, taking the "wrong" route sometimes paid off, and when it didn't you certainly weren't killed off, but simply found yourself in an unproductive region or a very tight spot!

On the Island, take the "wrong" path and you will find yourself dead very quickly. **D.M.**

instructions	n/a
playability	80%
graphics	80%
value for money	95%



## Tomb of Dracula 48K Spectrum £6.95

K'Tel, 620 Western Avenue, London W3

This game is another variation of the multi level adventure/maze type. Alas it is hardly inspired.

You must enter Dracula's

chamber system and delve into as many levels as possible prior to sunset and Dracula's awakening. After this your progress becomes a little harder.

Other horrors to be avoided are ghouls, zombies, and slime pits. When you light on a surprise vault you may be lucky enough to add to your valuable (and useful) collection of silver stakes.

These can be used to kill opponents or pay for a glimpse of the map of the level in which you

are currently located. I must admit I did not venture very deep but I hardly found it compelling.

The game is not very dynamic. The graphics are average, but certainly not startling.

3D views of vaults are given but add little to what you can imagine — helpful only if you have a poor sense of direction.

Use of colour is fair and there is the usual round of morbid minor key tunes.

All in all there is nothing new

here in concept or execution, so I think it must join a legion of similar programs that are something less than top flight. Certainly at £7 it is overpriced. **P.C.**

instructions	80%
playability	70%
graphics	50%
value for money	40%



## Black Tower TI-99/4A £5.95

Lantern Software, 4 Haffenden Road, Tenterden TN30 6QD

Black Tower is a text-based adventure game of the rescue-the-damsel variety.

There are 10 locations to visit, so far as I know, and of course you must be in possession of the right articles or pieces of information in order to proceed to the next one.

Defeat can come in many different ways and I must have found them all. When this happens it's back to the old castle gate and start again.

Commands are entered in the usual verb-noun form, though short sentences are also accepted.

If your input is too wordy, however, it may cause the program to fail as I discovered right at the start.

I thought "Look for a door" was a good idea, but it was too much for the computer, so the game stopped right there. Oddly enough, "Look for door" was accepted.

I managed to solve this game after three to four hours spread over a couple of days. Since this is my first attempt at an adventure game I take this to mean that Black Tower is quite easy to beat. The alternative is that I am very talented.

I found this game quite enjoyable, though once solved, that's it. Instructions are adequate, but a list of keywords would be nice. **C.E.**

instructions	50%
playability	75%
graphics	n/a
value for money	60%



## Kraal's Kingdom VIC-20 plus 16K £4.95

Buntasoft, 149 Monks Walk, Buttingford, Herts SG9 9DS

Writing a good adventure is, in many ways, much more difficult than you would think. The problems are exacerbated by lack of memory.

This author attempted to overcome this lack by writing the game in two parts. This nearly works, but is foiled by some appalling mistakes in technique.

The scenario is standard enough. You charge around the place endeavouring to acquire the necessary impedimenta to rescue the princess.

The descriptions of the locations are good and the screen handling adequate. The main

black spot is the interpretation. The author uses the method of expecting certain fixed commands only. This means that rather than a fixed two word command, several words may be expected. This saves memory but makes play a nightmare.

As a result, I got stuck on a plank in the middle of a lake. Only by cheating could I find which specified phrase was expected.

I found the game a little dry and lacking humour. In spite of these moans, at the price it is very good value and is guaranteed to drive you to the extremes of despair (as you to the extremes of despair (as any adventure should). I wouldn't, however, recommend it for a beginner. **A.W.**

instructions	60%
playability	60%
graphics	n/a
value for money	90%



**TNT** SOFTWARE



## CENTIMUNCH

Special introduction offer  
£5.95 (inc P&P and VAT)

**FOR THE 48K SPECTRUM**

An original game with on-screen scoring plus Hi-Score. Watch out for the Spider, mind the Bees don't confuse. Remember eat all your veg, a Super Carrot can improve your eyesight — now you can see the gate. Careful round those Rocks. Can you survive a full 12 months in a garden like this?

DEALER ENQUIRIES WELCOME —  
RING 0229 27324

Please send Cheques or P/Os to:  
**T.N.T. Software, Dept B**  
**Melton House, Lindal**  
**Ulverston, Cumbria**

I ENCLOSE £.....

NAME .....

ADDRESS .....

HCW41

## ONE MAN'S VIEW

# How you can spot the cowboys

*With home computers being as popular as they are today, more and more software companies are setting up and marketing their programs.*

*In the run up to Christmas many of these will be sold to both newcomers and experts in this field.*

*About half of the buyers of these programs will not be totally satisfied with what they get.*

*The fact of the matter is that there are still a lot of cowboys lurking behind glossy cassette inlay covers and flashy advertisements.*

*So how do you tell the difference between a high quality software company and one that is only after your hard earned cash?*

*The best way is to see the software working before you buy it. Unfortunately this is not always possible so you may have to judge it by other means.*

*The second best way is to buy from companies who print screen displays on their adverts and/or cassette inlay cards.*

*Companies who do this obviously want you to see the high quality of their programs — they don't need an artist to paint you a picture of what the game could, but will not, be like.*

*The third way of assessing programs is to read software reviews, such as the ones in this magazine. They will tell you the theme, quality, value for money and faults of the program. They are of course dependent on the reviewer's taste in programs, but even so will be given a fair review.*

*When looking around at programs you should expect top quality software.*

*Games should be of arcade quality. Expect them to be written in machine code, make full use of graphics and sound and exploit your computers abilities. Text/logic games should be well presented and easy to use.*

*Educational software should be easily understood and useful, not a computerised gimmick. It should be able to help you learn about a specific subject easily.*

*Utility and business software should make full use of your computer system. Ease of use and a neat output is essential in this type of application.*

*If there is a similar but better program available at a higher price then I would advise you to consider the better one — there is nothing worse than having to go about things the long way when there is an easy short cut available.*

*Software standards will only be as high as you set them. If you insist on the best, then the rubbish will dwindle away and more high quality software will be available at prices we can all afford.*

**Kevin Irving**  
Software Reviewer  
Carlisle,  
Cumbria

# The ultimate Crossword

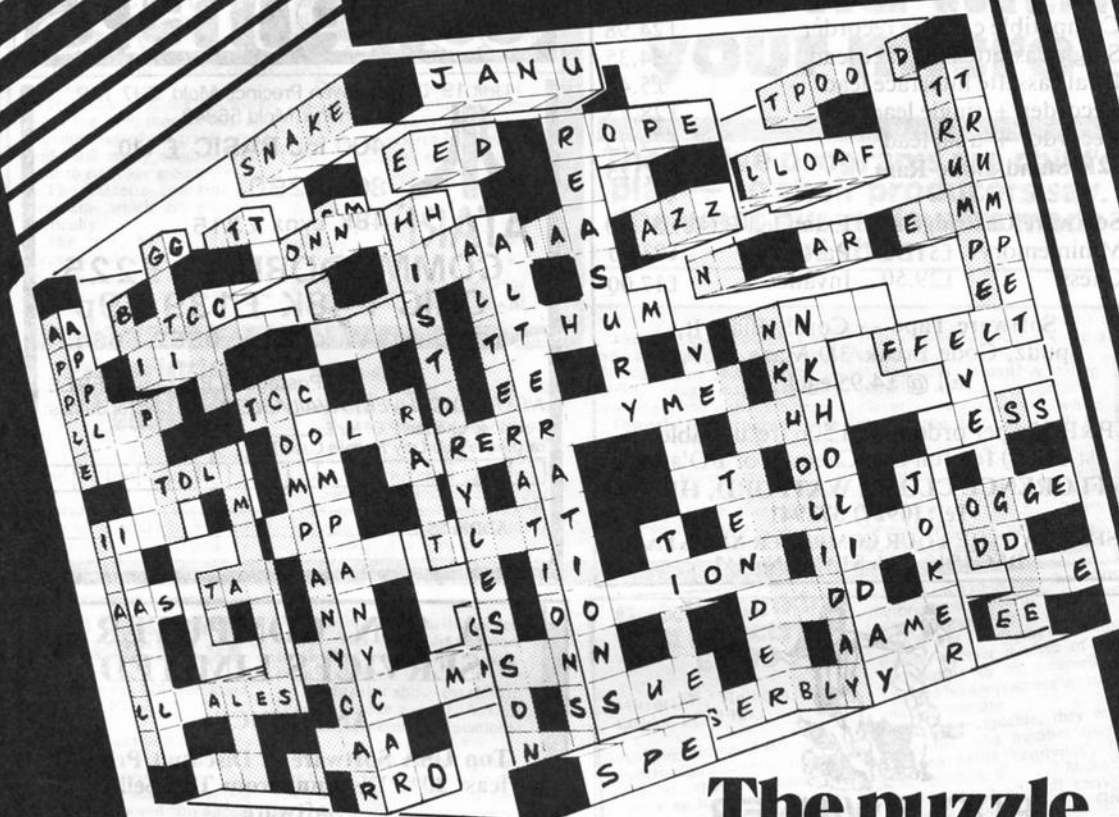

## The puzzle that needs a computer

Alien present the ultimate in word puzzles - 30 integrated crosswords which form a cube.

All locations of this 3 dimensional puzzle are contained in the computer programme and you can complete any part you wish using the display on your T.V. and computer keyboard. Understanding all the relationships between the

crosswords is not possible without the computer but as you proceed you will discover new routes to help achieve the solution.

**Features: Solution Store, Instant Display, Anagram Function, Character Location in memory.**

This is a tough puzzle with a degree of difficulty - it's the ultimate but it's not impossible. Full instructions are included with the programme.

**★ £1,000 PRIZE**  
to sender of first correct taped solution run on our computer on 1st June 1984

Please mail me  copies of the Alien Ultimate Crossword puzzle programme at £14.95 per copy inc. P. & P. for the  
 BBC Model B  Commodore 64  Spectrum 48K  
 I enclose £\_\_\_\_\_ or my Access/Visa Card No. is \_\_\_\_\_

Name \_\_\_\_\_

Address \_\_\_\_\_

Postcode \_\_\_\_\_



**The New Dimension**

The Alien, Arndale House, Church St,  
Blackburn, Lancs. BB7 5AF.



Please allow 14 days for delivery



## First Steps with the Mr. Men 32K BBC £8.95

Mirrorsoft, Holborn Circus, London EC1P 1DQ

Using computers with young children is not as easy as people assume — it very much depends on the quality of software that is available.

This package is one that works — it's a well-thought-out and executed set of programs which will thrill many children in the four to eight age group.

The cassette contains four programs which are graded in difficulty.

The first, Mr Greedy's Ice Cream Hunt, is simply an attempt to improve hand/eye co-ordination and uses colour to assist direction.

Mr Silly's Hat Game is the weakest program on the cassette, because it takes far too long to finish. The aim here is to select the hats that Mr Silly wants, learning shape and colour matching in the process.

The final two games feature Mr Forgetful, who has lost either his clothes or letters of the alphabet in his 14 wardrobes. This is basically pair matching, but is very well done except for the tune at the end.

The package also contains a 24-page full colour book of Roger Hargreaves stories to explain, and interest the children in the games, plus a direction key template.

instructions	100%
ease of use	90%
display	90%
value for money	95%



## Pathfinder Spectrum £5.95

Widgit Software, 48 Durham Road, London N2 9DT

Before numbers, or anything else, make sense, children need to be able to explore and practice with

basic concepts.

Here, Widgit offers a real learning opportunity for pre-school and primary age children.

In a series of four well presented maze games featuring animals, the child can practice counting, explore such concepts as up, down, left and right, and begin to develop the ability to plan moves in advance.

## Fun To Learn 32K BBC £6.95

Shards Software, 189 Eton Road, Ilford, Essex IG1 2UQ

This set of programs is written by a teacher and aimed at the six to 12 year old age group.

Count is a simple counting exercise which should only appeal to the very young. I wasn't impressed.

Mixer is a little better. It displays a mixed-up word which the child decodes. Words can be selected by the computer, or the children can enter their own words for a friend.

Calculator is a simple simulation of a pocket calculator. Quite effective, but I am a little unsure of its educational value.

Starship is probably the best part of the program. Similar to Hangman, the object is to find the

word before your starship is destroyed. This should appeal more to children because of its competitive element.

Codebreaker allows the child to code or decode a word. Again I have doubts about its educational value.

The programs are well written. The display uses large double size teletext characters which is very good for a group of children to observe together.

Colour is used to good effect and occasional musical pieces liven up the program. It is a good example of how educational software should be written, but some of the games lack imagination.

instructions	75%
ease of use	90%
display	100%
value for money	65%



## School Maze Dragon £10.95

Dragon Data, Kenfig Industrial Estate, Margam, Port Talbot

Some software houses show an annoying tendency to produce programs for children of a far lower standard than those aimed at adults, but with a similar (or in this case, higher) price-tag.

This is a prime example of the phenomenon — a fairly short and unsophisticated BASIC program which I feel should have been developed much further before being unleashed onto the public.

It is an adventure-type game with a few short distractions thrown in.

A map of the school is shown at intervals, but movements within the program are not always as the map would lead you to expect.

At some points you use the cursor keys to move an arrow on the map — it is an upward pointing arrow regardless of the direction in which you are going, and the keys used do not auto-repeat.

In the school gym you are invited to play basketball; the previous position of the ball is not blanked out as it moves, so you get a trail of black squares across the screen.

The options offered in the Music and Art rooms are similarly crudely done.

To be fair, though, I must add that my children and their friends liked it.

instructions	50%
ease of use	60%
display	10%
value for money	10%



# Kidding around with your micro

These five programs are child's play — so their producers say. See what our reviewers made of them

You may be tempted to ask why these are important. Try driving, playing chess, programming in BASIC, using a map, or finding your way home without them!

Though the programs are largely in BASIC, they are well written, colourful, attractive and make good use of sound.

Much more important in an educational sense, they are well structured and purposeful, providing useful experience in a way

that would be difficult without a computer.

Well done, Widgit! A real application for a home computer, cleverly executed and which doesn't cost the earth.

instructions	75%
ease of use	90%
display	85%
value for money	100%



## Quick Thinking 48K Spectrum £6.95

Mirrorsoft, Holborn Circus, London EC1P 1DQ

Although they deal with addition, subtraction and multiplication of numbers, these programs will not teach such complex processes. They merely provide the opportunity to practice what has already been learned in an enjoyable way.

The presentation of the cassette is excellent, both visually and textually.

The programs — written for Mirrorsoft by Widgit — are equally good, with superb use of colour and shape, though the Spectrum's screen shimmer makes reading numbers difficult.

SumVaders has a mother ship dropping robots; add the num-

bers on each to destroy the robot before it reaches earth. When five land, the game is over.

In Robot Tables, the child must decide whether a piece of raw material is to be accepted or rejected before reaching the robot making machine.

To be acceptable, they must have the next number in the chosen table sequence, for example 2, 4, 6, ...? Make the wrong choice and all sorts of fascinating things happen. Great graphics!

Criticisms? Robot Tables practices tables in sequence, but we use them out of sequence in everyday life. It needs a random element.

instructions	90%
ease of use	100%
display	90%
value for money	90%



# There's a terrific draught in here!

Make your Oric quicker on the draw with this program by father-and-daughter team Brian and Sarah Grayson

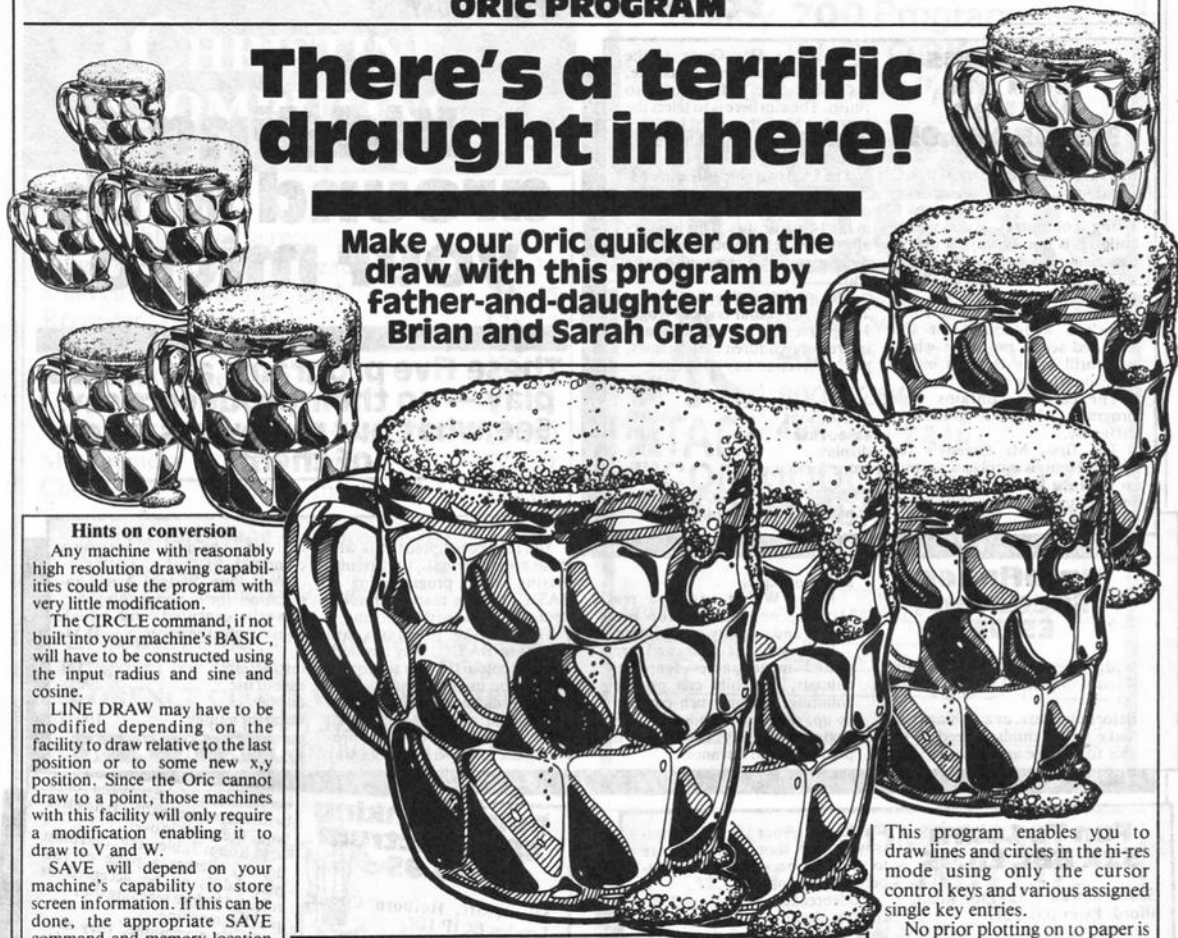

### Hints on conversion

Any machine with reasonably high resolution drawing capabilities could use the program with very little modification.

The CIRCLE command, if not built into your machine's BASIC, will have to be constructed using the input radius and sine and cosine.

LINE DRAW may have to be modified depending on the facility to draw relative to the last position or to some new x,y position. Since the Oric cannot draw to a point, those machines with this facility will only require a modification enabling it to draw to V and W.

SAVE will depend on your machine's capability to store screen information. If this can be done, the appropriate SAVE command and memory location will need to be inputted.

DELETE uses the Oric facility to use foreground on background colours. Most machines have a different facility and this part of the program should incorporate the appropriate command to produce an inverse of the normal display.

Most machines use ASCII codes, so the keyboard sensing should not present any difficulties. Only the cursor movement keys will need to be checked.

Remember to place the border slightly inside the full screen size to avoid the program stopping because it is out of range.

### How it works

- 5 clears the screen and sets up the title sequence and instructions
- 10-20 draws the border, sets the initial cursor position, normal mode, and pixel movement (5)
- 30-130 reads the keyboard input and resets the variables or sets up mode
- 200-206 senses if a line is already on the screen to avoid wiping it out as the cursor flashes
- 400-602 title and instructions
- 1000-1040 tape save and reset or program termination

```

1 REM *** ORIC DRAUGHTSMAN ***
2 REM ** by B.D. & S.L. GRAYSON July '83 *
*
5 CLS:GOTO400
10 HIRES:PRINTCHR$(20);CHR$(17)
15 CURSET0,0,1:DRAW239,0,1:DRAW0,199,1:D
RAW-239,0,1:DRAW0,-199,1
20 X=120:Y=100:T=1:I=5
30 K$=KEY$
32 IFK$=CHR$(49)THENI=1
33 IFK$=CHR$(50)THENI=2
34 IFK$=CHR$(53)THENI=5
35 IFK$=CHR$(48)THENI=10
40 IFK$=CHR$(8)THENX=X-I
50 IFK$=CHR$(9)THENX=X+I
60 IFK$=CHR$(10)THENY=Y+I
70 IFK$=CHR$(11)THENY=Y-I
80 IFK$="P"THENCURSETX,Y,T:GETK$:GOTO32
85 IFK$="Q"THENTEXT:RUN
90 IFK$="C"THENCURSETX,Y,1:PRINT"Wha t r a
d i u s ?":INPUTR:CIRCLER,T:GOT
030
    
```

This program enables you to draw lines and circles in the hi-res mode using only the cursor control keys and various assigned single key entries.

No prior plotting on to paper is required as the cursor is used to 'compose' direct on the screen.

The assigned keys are self-explanatory and detailed in the program they are:

**P** to fix a point to which lines may be drawn from any other cursor position

**C** to draw a circle, you must input a radius when requested

**L** to draw a line to the point previously 'fixed'

**D** to enter the delete mode when every subsequent action is drawn in the background colour (wiping out a previous foreground feature)

**N** to return to the normal mode  
**Q** returns to the instructions but beware, all your work will be lost

**S** to save the drawing on the screen. Position a blank piece of tape and start to record before pressing S

Cursor movement is achieved with the arrow keys, and the distance moved may be varied by 1,2,5 or 10 pixels by pressing 1,2,5,0 at any time. Best control will be achieved by using 5 or 10 until you are near to your desired position, then changing 1 or 2 for final positioning.

## ORIC PROGRAM

```

95 IFK$="S" THEN GOTO 1000
100 IFK$="F" THEN CURSETX,Y,1:CIRCLE4,1:CLS:PRINT"Line draw":U=X:W=Y

110 IFK$="L" THEN CURSETU,W,0:CIRCLE4,0:CURSETX,Y,1:DRAW(U-X),(W-Y),T

120 IFK$="D" THEN PRINT"Delete mode":T=0:GOTO 030
130 IFK$="N" THEN CLS:T=1:GOTO 030
200 IF POINT(X,Y)=-1 THEN CURSETX,Y,0:WAIT5:CURSETX,Y,1:GOTO 030
201 IF POINT(X,Y)=0 THEN CURSETX,Y,1:WAIT5:CURSETX,Y,0:GOTO 030
400 POKE 618,2:PAPER0:INK7
401 IF PEEK(524)>127 THEN PRINT CHR$(20)
402 PLOT 16,8,20:PLOT 17,8,"ORIC":PLOT 22,8,16
404 PLOT 12,12,20:PLOT 13,12,"DRAUGHTSMAN":PLOT 25,12,16
450 WAIT 175:CLS
455 PRINT:PRINT:PRINT:PRINT
460 PRINT"This Oric program allows you to draw"
462 PRINT"lines and shapes in the computer's "
464 PRINT "HIRES mode."
466 PRINT "Only a few single key commands "
468 PRINT "are necessary.":PRINT
469 PRINT "The finished drawing may be"
470 PRINT "saved onto tape and subsequently"
471 PRINT "reloaded and displayed, though"
472 PRINT "not modified.":PRINT
475 WAIT 1500:CLS
500 PRINT" These are:-":PRINT
506 PRINT"The normal cursor control keys":PRINT
507 PRINT"P - To fix a point":PRINT
508 PRINT"C - To draw a circle - you must input a radius":PRINT
509 PRINT"F - To fix a point to which you may"
510 PRINT " draw lines from other points":PRINT
511 PRINT"L - To draw a line from the current"

```

```

512 PRINT" position to the 'F' point":PRINT
513 PRINT"D - To enter the delete mode."

514 PRINT" Lines and circles when drawn in "
515 PRINT" the normal way will be erased":PRINT
516 PRINT"N - To return to normal mode":PRINT
517 PRINT"Q - To quit the program and return"
518 PRINT" to this list. ALL IS LOST!":PRINT
524 PRINT CHR$(27) "L Press SPACE to continue"
525 GET Z$:IF Z$=CHR$(32) THEN CLS
528 PRINT:PRINT:PRINT:PRINT:PRINT
530 PRINT"S - This automatically saves the "
531 PRINT " finished drawing on tape"
532 PRINT" REMEMBER TO POSITION SOME BLANK"
533 PRINT" TAPE AND START THE CASSETTE BEFORE PRESSING 'S'"
534 PRINT" To recover the drawing type"
535 PRINT" HIRES before 'LOAD'"
536 PRINT:PRINT:PRINT:PRINT
550 PRINT" The distance the flashing cursor"
552 PRINT" moves may be varied at any time"
554 PRINT" by inputting 1,2,5,0 for 1,2,5,10"
556 PRINT" pixels.It is normally 5."
590 PRINT:PRINT:PRINT:PRINT:PRINT
8000 PRINT CHR$(27) "L Press SPACE to begin"
602 GET Z$:IF Z$=CHR$(32) THEN GOTO 100
1000 PRINT"saving in progress"
1010 CSAVE"",A40960,E49000,AUTO
1020 CLS:PRINT"Saving complete. Do you wish to continue Y/N?"
1030 INPUT R$:IF R$="Y" THEN GOTO 10
1040 IFR$="N" THEN TEXT:CLS

```

# At £99 the Manta Printer is a bargain!

Whatever image or text is displayed on your screen the Manta Printer can reproduce it – graphics or characters. Running quietly and quickly – at 80 characters per second – the Manta produces 40 column width print-out in upper and lower case letters and graphics.

Take this opportunity to upgrade your system – produce hard copy print-out of all your programs, lists, addresses etc.

The Manta printer is fully compatible with Spectrum 48K, Oric, Dragon, VIC 20, Commodore 64, Aquarius and BBC.

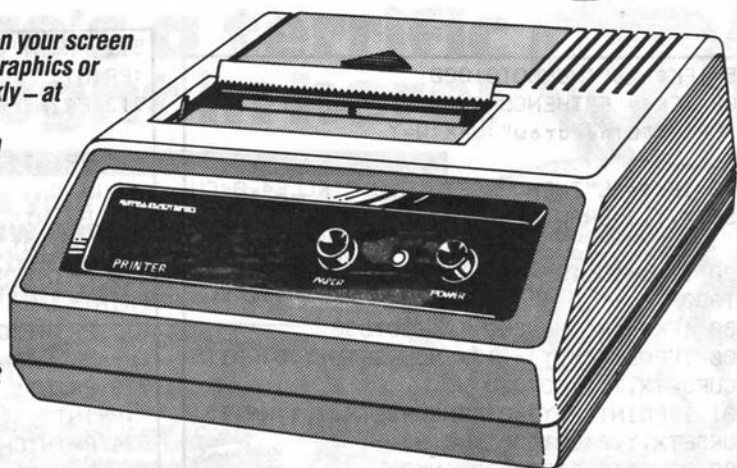

## With £100 of FREE software its a steal!

Buy the Manta Printer and choose £100 of software free!



### Dragon 32, Spectrum 48K, Oric 48, Commodore 64

Leopard Lord  
Terror from the Deep  
Ace in the Hole  
Horror Atoll  
Arcane Quest  
Roundsby Incident  
all at £10 each

### Spectrum 16K

Fisherman Fred  
E x T  
Penguin  
Sea-battle  
Cosmanoids  
Diamond Mine

Golf  
Toolkit  
Grid Bug  
all at £5 each

### Spectrum 48K

Cry Wolf  
Ziggurat of Dread  
Tobor  
Chuckman  
Lost over Bermuda  
3D Star Wars  
Security Shelter  
One-arm Bandit  
Efenders  
Eteor Torn  
'N' Vaders  
Terroroids  
Goblin Crusher  
Never Trust a Blonde  
all at £5 each

### Vic 20

Games Pack 1  
Fruit Shop  
Sea Wolf  
Cube  
Packman

### Games Pack 2

Frogger  
Invaders  
Othello  
Roboball

### Games Pack 3

Head On  
Apollo 8  
Wobble Board  
Space Attack

### Games Pack 4

Crazy Balloon  
Sea War  
Mazerace  
Breakout  
all at £10 each

### Aquarius Cassettes

Ed-on  
Grid Bug  
Phrogger  
'N' Vader  
Chuckman  
Efenders  
Aliens  
One Arm Bandit  
all at £5.95

### Aquarius Cartridges

Chess £19.95  
Melody Chase £19.95  
Snafu £15.95  
Night Stalker £19.95  
Lock 'n' Chase £19.95  
Astrosmash £15.95  
Burger Time £19.95  
TRON £19.65  
Dungeons and  
Dragons £16.95  
Logo £30  
Finform £30  
Fileform £30

### BBC

Picnic Adventure  
only £5

# ADD ON ELECTRONICS

Add-On Electronics Ltd.,  
Units 2, 3 and 4,  
Shire Hill Industrial Estate,  
Saffron Walden,  
Essex CB11 3AQ

To: Add-On Electronics Ltd., Units 2, 3 and 4, Shire Hill Industrial Estate, Saffron Walden, Essex CB11 3AQ

Please rush me \_\_\_\_\_ (qty) MANTA Printers at £99 each. My machine is \_\_\_\_\_

I enclose cheque to the value of £ \_\_\_\_\_ or debit my Access

No. \_\_\_\_\_

Name \_\_\_\_\_ Signature \_\_\_\_\_

Address \_\_\_\_\_

Postcode \_\_\_\_\_

I claim £100 of free software from the list above:

If not enough space kindly attach list. Prices include VAT and P+P.  
Credit card holders ring (0799) 25014 (24 hours) or Telex 81653



## The Joy of Joysticks

I have been a TI owner since the end of April this year, and am very grateful to the few magazines, such as yours, which take a real interest in the Texas micro.

However, very few of the programs in magazines such as yours seem to use the Texas joysticks. Though these joysticks are not the ultimate in good design, they can add another dimension or variation to games that would otherwise become boring.

Now before anyone tells me to get off my peripherals, plug in my modules and write a program myself, I'd like to say that I am doing just that — it will be a maze game, using joysticks, and when it has been fully debugged you might just get to see it.

Meanwhile, here is a joystick routine for the Apple Scrumpling game printed in HCW 37. Replace lines 395 to 440 with the following:

```
395 CALL JOYST(1,A,B)
400 CALL HCHAR(Y,X,
32)
405 IF (A<>-4)+(B<>
0) THEN 415
410 X=X-1
415 IF (A<>4)+(B<>0)
THEN 425
420 X=X+1
425 IF (A<>0)+(B<>4)
THEN 435
430 Y=Y-1
435 IF (A<>0)+(B<>
-4) THEN 445
440 Y=Y+1
```

This routine can, with slight modification, be used on many other games.

By the way, I typed this letter myself, in less than 10 minutes, but prior to obtaining my Texas this could have taken anything from two to three months without the practice on a real keyboard.

I doubt this improvement would have been the same using a Spectrum or Oric! I reserve the right to remain a bad speller, though.

Tony "Tonks" Huby,  
Bramley, Leeds

## Peace on earth — and elsewhere

I appeal to everyone who will be buying, giving or receiving computer games this Christmas to stop and think before making their choices.

I put it to you that encouraging young people to play games the purpose of which is to kill, bomb, shoot, conquer, destroy and show as much aggression as possible is as sick as forcing them to watch "video nasties".

In fact it is sicker, because

Send your letter to Letters, Home Computing Weekly, 145 Charing Cross Road, London WC2H 0EE. Don't forget to name your computer — the best letter could win £5-worth of software. Got a problem with your micro? We'll soon be starting a queries page, so send your technical questions to Queries at the above address



with computer games they must actively participate.

It is a tragedy that while British home micro software leads the world in technical quality, the vast majority of the themes of "games" appear to have been thought up by the minds of mass-murderers to give pleasure to admirers of Adolf Hitler, Jack the Ripper, Attila the Hun and Denis Nilsen.

Look through the adverts in this magazine and feel shame. We have allowed this to happen, and we are all responsible, programmers, advertisers, magazines and shops.

We are using the greatest innovation of our age to teach kids that killing is OK. Pick your presents with care. Happy Christmas. Peace and goodwill to all Mankind, and Aliens.

Mel Croucher, Automata,  
Portsmouth, Hants

## Computer talk from Norfolk

I seem to have achieved fame — or is it notoriety? — since having a letter published in HCW 31. Not that I'm complaining, as several people took the trouble to get in touch with me — in this neck of the woods, computerising females are a bit thin on the ground, and we need to stick together.

Is there a postal club for adventure game players? If not, would anyone be interested in starting one? I work full time, and don't honestly have the time to run a club, but I would be willing to help.

On the subject of adventure games, has anyone found all seven pieces of parchment in *Invincible Island* (Spectrum 48K)? I've found six, and can't find number seven. Help!!!!

If your child is anything like my daughter, she'll spend hours and hours drawing and colouring patterns. The following two lines help keep them quiet over Christmas!

10 PRINT (Your choice of

graphics, UDGs, spaces);

20 GOTO 10

This gives a screenful of pattern, and can easily be altered by adding or removing shapes or spaces. Enterprising parents can, by adding a few more lines, allow the child to choose paper and ink colours.

On to the complaints section. I've had dealings by post with four companies. Three out of the four have been excellent — Hewson, Gilssoft and Virgin Games. Who gets the booby prize? Quicksilver, that's who. I sent off a cheque to them for their *Game Lords* Club. It was cashed promptly, but it was over a month before I heard anything from them. Pity. Especially as some of their games are so good.

A. Bates (HCW 38) (No relation as far as I know) is lucky to have got her husband interested in computing. So far, apart from playing the odd game, the most interest mine has shown has been when I put in a simulation of a two-stroke engine.

He liked that, and thought that it might be of some use! Oh well, I shall just have to write a program of motorbike racing!

Best wishes, Happy Christmas, and keep up the good work.

Patricia Bates, North Walsham, Norfolk

Mark Eyles of Quicksilver said: "The *Game Lords Club* is handled by a professional mail order company, and they're normally very quick — perhaps Mrs Bates's order got held up by the Christmas post. If she has any further problems, she should contact us at Quicksilver directly, and we'll do our best to help. By now, she should have received the first issue of the *Games Lord* magazine, anyway, which should be some consolation — we think it's really good!"

## Cheat the jetman

Amaze your friends with your high score on *Jet Pac*, thanks to a slight scoring fault in the program.

On the fourth sheet of *Jet Pac* there are plane-shaped objects which, when they explode, give you points. If the jetman is placed on the top right hand cloud he cannot be killed.

So if the television is switched off and the computer left on, the program will continue to accumulate a steady score, and if left long enough, any score can be reached without laying a finger on the keyboard!

M. Brunning, Bispham, Blackpool

# The sceptre of Cadarian

**Deep underground, evil things await those foolhardy enough to venture into Radro. Marc Freebury's adventure game was written for an Atari 800 with discs, but you can easily convert it to cassette**



Ready for combat — a scene from Hawk the Slayer

"... And whosoever recovers the sceptre will be made heir apparent to the throne of Cadarian. Signed, his most royal majesty Cydran IV, midsummer's day."

The herald remounted and spurred his horse on, to repeat the message in the next village.

Radro. They all knew that name, he reflected, yet few remembered the Underground Fortress of Evil at the height of its power.

The Castellan had often spoken of it, on the dawn watch. "Many were the fallen. Some say 10,000 warriors breaching the upper defences, and 10 times that number in a futile attempt to secure the labyrinth beneath.

"But ours was the victory, if not the war. Radro was tamed if not broken, and the entrance sealed with mighty magicks. In our vanity we thought it ended."

The old man would shake his head. "Then fell forces attacked the palace, and removed the sceptre of rule, without which our king is powerless. And then to find the entrance to Radro unsealed... evil times to be sure. That is why you, young man, declare the challenge to the people."

Again the silver-grey hair would shake back and forth. "But few of true noble blood yet live, and none will dare the entrance. The memory of terror lies too strong upon the land."

The herald urged his mount on, shivering despite the clear sky and golden sun overhead.

## How to play

This game is so big that I had to split it into two programs. Together they occupy over 200 disc sectors.

In order for the game to work, the first program should be called 'CASTLE.BAS' and the second 'MAZE.BAS'.

The present version is for disc only, but conversion to cassette is a simple matter. First, all references to 'NAME.DAT' should be removed, as should all XIO statements.

Change all occurrences of "D:" to "C:". Lastly, insert a piece of code at the front of MAZE.BAS to ask for the player's character name.

In order to sustain interest, the game has been made strategically complex, although it is hoped that play itself is a simple matter.

When entering the castle for the first time, ask for a new character (note: most one-letter user replies do not require you to press return.) Keep a close eye on your gold supply as you wander around the market stalls.

If you wish to skip an option at any time or wish to avoid paying for something, type a zero. When you are sufficiently prepared, use

option 5 from the courtyard to enter the maze.

Once at the maze entrance, you can retrieve a previously saved level by telling the doorwarden, and giving the name the level was saved under (usual eight-letter limit applies).

Once you descend the stairs, you will be given a three-dimensional view of the road ahead. At this stage it is a good idea to start drawing a map so that you can find your way back to the original stairs.

Movement is via the keys W,A and D — use A and D for turning on the spot and W to advance one step.

The maze plotter is written to be very fast, and as such has one slight defect. If two consecutive 'blocks' of the 20 by 20 grid are open to your left or right, a ghost wall will be created. These are easily spotted and should prove only a minor irritant at first.

Eventually you will encounter something. Treasure is randomly distributed and is not carried by monsters, since they have no use for objects.

Speaking of monsters, combat is also likely. Up to six monsters may attack simultaneously and can easily hack you to pieces if you are foolhardy (or brave as some would have it) enough to stand your ground.

There are five combat options. First, hack at one monster with your sword. Second, run away.

Third is an option to cast one of the four spells available. These can only be cast if you have enough spell ability (gained from magical objects).

The first spell is 'sleep'. It will cause one monster to become drowsy, allowing you one free swipe.

Next is Fireball, causing one monster to lose nearly all its hit points.

Third is Rock To Mud. This lashes out magical power and dis-integrates one block of the maze around you. Naturally this display of power will cause the monsters to be temporarily cowed.

Lastly is Teleport, which moves you at random.

Death. It reaches us all eventually. If your hit points reach zero, you die. Coming out of the maze restores all lost hit points.

Experience points are gained for monsters killed, and when enough have accrued, your character's level will increase, as will the upper limit of his hit points. Your rating as an adventurer will be indirectly tied to your level.

That is a basic outline of the game. Of course, there are things left unexplained but you'll find them out... (har har!)

```

100 REM **
*****
110 REM *
120 REM * RADRO! FANTASY/ADV *
130 REM * BY M.FREEBURY *
140 REM *
150 REM *****
160 DIM NAME$(20),NAME2$(20):TRAP 180
170 OPEN #1:4,0:"D:NAME.DAT":INPUT #1,N
AME$:CLOSE #1:FLAG=1:GOTO 460
180 CLOSE #1:GRAPHICS 8:SETCOLOR 2,0,0:
COLOR 1:SETCOLOR 1,0,0
190 DATA 360,120,40,80,70,80,70,100,40,
100,70,120,410,120,103,80,120,416,1
03,114,103,460,120,140,80
200 DATA 360,120,40,80,70,80,70,100,40,
100,70,120,410,120,103,80,120,416,1
03,114,103,460,120,140,80
210 DATA 170,100,140,120,510,120,190,80
,220,80,220,100,190,100,220,120
220 DATA 560,120,240,80,270,80,270,120,
240,120
230 DATA -1,-1
235 REM *** DRAW FRONT PAGE ***
240 RESTORE 200
250 READ X,Y:IF X=-1 THEN 280
260 IF X>320 THEN X=X-320:PLOT X,Y:GOTO
230
270 DRAWTO X,Y:GOTO 250
280 FOR I=40 TO 270 STEP 5:PLOT 160,0:D
RAWTO I,80:NEXT I
290 ? CHR$(125):POKE 732,1:? ? * RADR

```

# ATARI PROGRAM

```

0 : THE UNDERGROUND FORTRESS *
300 POKE 709,15
310 DIM DELAY(3):DELAY(1)=75:DELAY(2)=1
50:DELAY(3)=250
315 REM *** PLAY INTRO ***
320 RESTORE 370:FLAG=0
330 READ NUTE,TYPE:IF NUTE=-1 THEN 450
340 SOUND VOICE,NUTE,10,8:SOUND VOICE+1
NUTE+1,10,8
350 FOR I=1 TO DELAY(TYPE):NEXT I
360 GOTO 330
370 DATA 72,1,76,1,72,1,76,1,72,1,96,1,
81,1,91,1,108,2,0,1,182,1,144,1,108,1
380 DATA 96,2,0,1,144,1,114,1,96,1,91,2
0,1,144,1,72,1,76,1,72,1,76,1
390 DATA 72,1,96,1,81,1,91,1,108,2,0,1,
182,1,144,1,108,1,96,2,0,1,144,1,91,1,9
6,1,108,1,0,2
400 DATA 96,1,91,1,81,1,72,3,121,1,64,1
72,1,81,3,128,1,72,1,81,1,91,3,144,1,8
1,1,91,1
410 DATA 96,2,144,1,72,1,72,1,95,1,76,1
72,1,76,1,72,1,81,1
420 DATA 72,1,76,1,72,1,96,1,81,1,91,1,
108,2,0,1,182,1,144,1,108,1
430 DATA 96,2,0,1,144,1,114,1,96,1,91,2
0,1,144,1,72,1,76,1,72,1,76,1
440 DATA 72,1,96,1,81,1,91,1,108,2,0,1,
182,1,144,1,108,1,96,2,0,1,144,1,91,1,9
6,1,108,1,-1,-1
450 FOR I=1 TO DELAY(2):NEXT I:SOUND 0,
0,0,0:SOUND 1,0,0,0
455 REM *** STRING DECLARATIONS ***
460 DIM ARM$(100)
470 ARM$="010 PADDED ARMOR020LEATHER AR
MOR060 CHAIN MAIL 100 PLATE MAIL 200
PLATE +1 "
480 DIM SH$(48):SH$="010 SMALL SHIELD05
0 LARGE SHIELD080 +1 SHIELD "
490 DIM WP$(170)
500 WP$="001 SHORT SWORD 005 BROAD
SWORD 020 LONG SWORD 050 TWO H
ANDED SWORD"
510 WP$(81)="100 +1 SWORD 150 +2
SWORD 300 LIFE STEALER 900 U
ORPAL BLADE "
520 DIM SPELL$(40):SPELL$="SLEEP FI
REBALL ROCK/MUD TELEPORT "
530 OPEN #1,4,0,"K:"
540 IF FLAG=1 THEN FLAG=0:GOTO 2150
550 GRAPHICS 0:SETCOLOR 2,0,0:DL=PEEK(5
60)+PEEK(561)*256:POKE DL+3,71:POKE DL+
6,7
560 POSITION 6,0:?"WELCOME!"
570 ? :?"To Caradian Castle.I am your
host,"
580 ? :?"Teraldor.Are you New or are you"
590 ? :?"Revisiting?":GET #1,K
600 IF K=82 THEN 2130
610 IF K<>78 THEN 550
615 REM *** NEW CHARACTER ***
620 ? :?"What be thy name,stranger ";
630 INPUT NAME$:IF LEN(NAME$)10 THEN ?
"WHAT do your friends call you ":GOTO
630
640 ST=INT(RND(1)*60)+10:DEX=INT(RND(1)
*75)+10:LV=1:LK=INT(RND(1)*6)+1:GD=INT(
RND(1)*2*(LK)+10
650 HP=INT(RND(1)*10)+LK:XP=0:SP=0:WP=0
660 WP=0:ARM=0:SH=0:PO=0
665 REM *** 500TH5AYER ***
670 GRAPHICS 0:SETCOLOR 2,0,0:DL=PEEK(5
60)+PEEK(561)*256:POKE DL+3,71:POKE DL+
6,7
680 POSITION (20-LEN(NAME$))/2,0:?"NAME
$
690 ? :?"SUMMARY OF CHARACTER :":
700 POSITION 5,5:?"STRENGTH :";ST;"/1
00"
710 POSITION 5,7:?"DEXTERITY :";DEX;"/
100"
720 POSITION 5,9:?"LUCK :";LK;
730 POSITION 5,11:?"GOLD :";GD;
740 POSITION 5,13:?"HIT PTS :";HP;
750 POSITION 5,15:?"LEVEL :";LV;
760 POSITION 5,17:?"EXP PTS :";XP;
770 POSITION 0,21:?"Press [RETURN]";:G
ET #1,K
780 GRAPHICS 0:SETCOLOR 2,0,0:DL=PEEK(5
60)+PEEK(561)*256:POKE DL+3,71:POKE DL+

```

```

6,7
790 POSITION (20-LEN(NAME$))/2,0:?"NAME
$
800 ? :?"KNOWN SPELLS :":? :?
810 IF SP=0 THEN ? :?"NONE":GOTO 830
820 FOR I=1 TO SP:?" " ;SPELL$(I-1
)*10+1,IK10):? :?NEXT I
830 POSITION 0,21:?"Press [RETURN]";:G
ET #1,K
840 GRAPHICS 0:SETCOLOR 2,0,0:DL=PEEK(5
60)+PEEK(561)*256:POKE DL+3,71:POKE DL+
6,7
850 POSITION (20-LEN(NAME$))/2,0:?"NAME
$
860 ? :?"WEAPON :";:IF WP=0 THEN ? "NO
NE":GOTO 880
870 ? :?"WP$((WP-1)*20+5,(WP-1)*20+20)
880 ? :?"ARMOUR :";:IF ARM=0 THEN ? "N
ONE":GOTO 900
890 ? :?"ARM$(ARM-1)*16+5,(ARM-1)*16+16)
900 ? :?"SHIELD :";
910 IF SH=0 THEN ? "NONE":GOTO 930
920 ? :?"SH$((SH-1)*16+5,(SH-1)*16+16)
930 ? :?"POTIONS :";:IF PO=0 THEN ? "NO
NE":GOTO 950
940 ? :?"PO
950 POSITION 0,21:?"Press [RETURN] ";:
GET #1,K
955 REM *** GAME CENTRE ***
960 TRAP 960:GRAPHICS 0:SETCOLOR 2,0,0:
DL=PEEK(560)+PEEK(561)*256:POKE DL+3,71
:POKE DL+6,7
970 POSITION 5,0:?"courtyard"
975 REM *** WORD 'COURTYARD' INVERSE **
*
980 ? :?"From here,you may visit"
990 ? :?"1) Castor,5oothsayer.He will
reveal":? " your personality."
1000 ? :?"2) Danito,greatest of the w
hite"
1010 ? " witches and expert in heali
ng."
1020 ? :?"3) Xonthar.Retired swordsm
an.now a
1030 ? :?" master smith."
1040 ? :?"4) Laureth.A hard-but fair
-treasure"
1050 ? " and equipment buyer."
1060 ? :?"5) RADRO.Leave the castle.G
o forth"
1070 ? " to fame and wealth - or dea
th!"
1080 ? :?"6) Temporarily leave the ga
me."
1090 POSITION 2,20:?"Which do you choo
se (1-6)":GET #1,K
1100 K=K-48:IF K<1 OR K>6 THEN ? CHR$(2
53):GOTO 1090
1110 ON K GOTO 670,1120,1310,1720,1970,
2000
1115 REM *** WITCH ***
1120 GRAPHICS 0:SETCOLOR 2,0,0:POSITION
17,0:?"Danito."
1130 ? :?" :?"In return for a small off
ering"
1140 ? :?"i will give you potions,made
from"
1150 ? :?"the rarest of substances."
1160 POSITION 5,10:?"How much will you
donate ":INPUT I
1170 I=INT(ABS(I)):IF I=0 THEN 960
1180 J=INT(RND(1)*10)+1:J=INT(J-LK*RN
D(1)):IF J=0 THEN J=1
1190 IF I<J OR I>GD THEN ? :?"Begone,5
coundrel !":FOR I=1 TO 500:NEXT I:GOTO
960
1200 POKE 752,1:FOR L=1 TO INT(I/J):ON
INT(RND(1)*4)+1 GOTO 1210,1230,1250,127
0
1210 POSITION 2,15:?"A mixture of Luce
rne,for strength ":ST=ST+INT(RND(1)*EK)
+1:IF ST>100 THEN ST=100
1220 GOTO 1280
1230 POSITION 2,15:?"Cayenne,for a fas
ter swordarm ":DEX=DEX+INT(RND(1)*LK)+1
:IF DEX>100 THEN DEX=100
1240 GOTO 1280
1250 POSITION 2,15:?"Asafetida.A luck-
bringer ":LK=LK+1:IF LK>6 THEN LK=6
1260 GOTO 1280
1270 POSITION 2,15:?"Comfrey root,for

```

# ATARI PROGRAM

```

healing." :PO=PO+INT(RND(1)*3)+1:IF PO>9
THEN PO=9
1280 FOR K=1 TO 500:NEXT K
1290 POSITION 2,15:FOR K=1 TO 40:" ";
:NEXT K:NEXT L
1300 GD=GD-J:GOTO 960
1305 REM *** SMITH ***
1310 GRAPHICS 0:SETCOLOR 2,0,0:POSITION
14,0:"Mastersmith."
1320 ? :? "Since you can only use 1 sword,shield"
1330 ? :? "or suit of armour at one time, I will"
1340 ? :? "only sell you what you do not have."
1350 IF WP<>0 THEN 1490
1360 ? :? "First, a sword ":"POKE 752,1"
:
1370 FOR I=0 TO 7:I+1;" > ";WP*(I*20+1.I*20+20):NEXT I
1380 POSITION 2,22:"Which one,sire ";
:GET #1,K:K=K-48:IF K<0 OR K>8 THEN 1380
1390 IF K=0 THEN 1430
1400 I=(K-1)*20+1:NAME2$=WP*(I,I+2):J=VAL(NAME2$)
1410 IF GD<J THEN 1380
1420 GD=GD-J:WP=K
1430 POSITION 2,22:"Press [RETURN]";
:GET #1,K
1440 IF ARM<>0 THEN 1530
1450 ? CHR$(125):POSITION 14,0:"Mastersmith."
1460 ? :? :? "Some Armour ":""?
1470 FOR I=0 TO 4:I+1;" > ";ARM*(I*16+1.I*16+16):NEXT I
1480 POSITION 2,22:"Which suit ";:GET #1,K:K=K-48:IF K<0 OR K>5 THEN 1480
1490 IF K=0 THEN 1530
1500 I=(K-1)*16+1:NAME2$=ARM*(I,I+2):J=VAL(NAME2$)
1510 IF GD<J THEN 1480
1520 GD=GD-J:ARM=K
1530 POSITION 2,22:"Press [RETURN]";
:GET #1,K
1540 ? CHR$(125):POSITION 14,0:"Mastersmith."
1550 IF SH<>0 THEN 1630
1560 ? :? "A shield,perhaps ":""?
1570 FOR I=0 TO 2:I+1;" > ";SH*(I*16+1.I*16+16):NEXT I
1580 POSITION 2,22:"Which one ";:GET #1,K:K=K-48:IF K<0 OR K>2 THEN 1580
1590 IF K=0 THEN 1630
1600 I=(K-1)*16+1:NAME2$=SH*(I,I+2):J=VAL(NAME2$)
1610 IF GD<J THEN 1580
1620 GD=GD-J:SH=K
1630 POSITION 2,22:"Press [RETURN]";
:GET #1,K
1640 GOTO 960
1645 REM *** TREASURE EXCHANGER ***
1720 GRAPHICS 0:SETCOLOR 2,0,0:POSITION
15,0:"Treasurer.":? :?
1730 IF WP=0 THEN 1810
1740 I=WP*3+INT(LK*3RND(1))
1750 ? "Your sword : I offer ";I
1760 POSITION 5,22:"Accepted (Y/N) ";
:GET #1,K
1770 IF K=78 OR K<>89 THEN 1790
1780 WP=0:GD=GD+I
1790 POSITION 2,22:"Press [RETURN]";
:GET #1,K
1800 ? CHR$(125):POSITION 15,0:"Treasurer.":? :?
1810 IF ARM=0 THEN 1890
1820 I=5H*7+INT(LK*3RND(1))
1830 ? "Your armor : I offer ";I
1840 POSITION 5,22:"Accepted (Y/N) ";
:GET #1,K
1850 IF K=78 OR K<>89 THEN 1870
1860 ARM=0:GD=GD+I
1870 POSITION 2,22:"Press [RETURN]";
:GET #1,K
1880 ? CHR$(125):POSITION 15,0:"Treasurer.":? :?
1890 IF SH=0 THEN 1950
1900 I=5H*2+INT(LK*3RND(1))
1910 ? "Your shield : I offer ";I
1920 POSITION 5,22:"Accepted (Y/N) ";
:GET #1,K

```

```

1930 IF K=78 OR K<>89 THEN 1950
1940 SH=0:GD=GD+I
1950 POSITION 2,22:"Press [RETURN]";
:GET #1,K
1960 GOTO 960
1965 REM *** HERE WE GO!!! ***
1970 POKE 752,1: ? CHR$(125);"FORWARD, ";
NAME$;"!"
1980 OPEN #2,8,0,"D:NAME.DAT":PRINT #2;
NAME$:CLOSE #2
1990 FLAG=1:GOTO 2040
1995 REM *** ENDGAME ***
2000 ? CHR$(125):POSITION 7,0:"LEAVE"
2010 ? :? "Do you wish ";NAME$;" to be"
2020 ? :? "placed in the INN for the duration ";
:
2030 GET #1,K:IF K=78 OR K<>89 THEN 2110
2040 NAME2$="D:"
2050 NAME2$(3)=NAME$
2060 OPEN #2,8,0,NAME2$
2070 ? #2;ST:#2;DEX:#2;LK:#2;HP:#2;LV:#2;XP:#2;WP:#2;ARM:#2;SH:#2;PO:#2;SP:#2;GD:#2;PO:
2090 CLOSE #2
2100 IF FLAG=1 THEN RUN "D:MAZE.BAS"
2110 TRAP 2120:XIO 33,#2,0,0,"D:NAME.DAT"
2120 GRAPHICS 0:SETCOLOR 2,0,0:POSITION
15,0:"GAME ENDED":? :? :END
2124 REM *** RESTORE CHARACTER ***
2126 REM *** FROM DISK ***
2130 GRAPHICS 0:SETCOLOR 2,0,0:"Your name,sire ":"INPUT NAME$:IF LEN(NAME$)>10 THEN 2130
2140 ? NAME$;" ,eh ?"
2150 ? :? "One moment, lord..."
2160 NAME2$="D:"
2170 NAME2$(3)=NAME$:TRAP 2190
2180 OPEN #2,4,0,NAME2$:GOTO 2200
2190 ? :? "Thy name is not known here.":CLOSE #2:FOR I=1 TO 500:NEXT I:GOTO 550
2200 INPUT #2;ST:INPUT #2;DEX:INPUT #2;LK:INPUT #2;HP:INPUT #2;LV:INPUT #2;XP:INPUT #2;WP:INPUT #2;ARM:INPUT #2;SH:INPUT #2;PO:INPUT #2;SP:INPUT #2;GD:INPUT #2;PO:CLOSE #2
2220 ? "Welcome back,my lord.Please step into"
2230 ? "the castle."
2240 POSITION 2,22:"Press [RETURN]";
:GET #1,K:GOTO 670
2245 REM *** PHEW !!! ***

```

```

100 REM *****
110 REM *
120 REM * RADRO - UNDERGROUND *
130 REM * BY MARC FREEBURY *
140 REM *
150 REM *****
160 DIM NAME$(20),NAME2$(80),GEN$(20),A(20,20),RATE$(120),STU(6),DUX(6),MAG(6),HIP(6),MON5$(110)
170 MON5$="ORC BRIGAND DRUID
BUGBEAR TROLL VAMPIRE MEDUSA
DEMON V LICH LVL 9DRAGON "
180 RATE$="BUMPKIN PEASANT ANATEUR
SWORDSMAN ADVENTURERKNIGHT SLAYER
RADROIST HERO DEMI-GOD "
190 RATE$(101)="GOD-TYPE 1"
200 OPEN #1,4,0,"D:NAME.DAT":INPUT #1;NAME$:CLOSE #1
205 REM *** MUST LOAD CHARACTER ***
210 NAME2$="D:" :NAME2$(3)=NAME$
220 OPEN #2,4,0,NAME2$:OPEN #1,4,0,"K:"
230 INPUT #2;ST:INPUT #2;DEX:INPUT #2;LK:INPUT #2;HP:INPUT #2;LV:INPUT #2;XP:INPUT #2;WP:
240 INPUT #2;ARM:INPUT #2;SH:INPUT #2;PO:INPUT #2;SP:INPUT #2;GD:INPUT #2;PO:CLOSE #2
250 HP2=HP:ST2=ST:DEX2=DEX
255 REM *** DRAW FRONT PAGE ***
260 GRAPHICS 8:SETCOLOR 2,0,0:COLOR 1:5:ETCOLOR 1,0,0
270 PLOT 100,160:DRAWTO 100,20:DRAWTO 240,20:DRAWTO 240,160:DRAWTO 170,90:DRAW

```

# ATARI PROGRAM

```

TO 100,160
280 POKE 709,12:POKE 752,1:? CHR$(125);
" ** THE ENTRANCE **"
290 ? " " ;NAME$
300 FOR I=1 TO 1500:NEXT I:GOTO 560
305 REM *** FAST MAZE PLOTTER ***
310 I=0:X1=0:Y1=0:XVEC=60:YVEC=32:XL=X:
YL=Y
320 ON DIR GOTO 330,340,350,360
330 XL=X-1:YL=Y+1:GOTO 370
340 XL=X+1:YL=Y+1:GOTO 370
350 XL=X+1:YL=Y-1:GOTO 370
360 XL=X-1:YL=Y-1
370 IF A(XL,YL)=0 THEN 400
380 PLOT X1,Y1+YVEC:DRAWTO X1+XVEC,Y1+Y
VEC:DRAWTO X1+XVEC,Y1+YVEC*4:DRAWTO X1,
Y1+YVEC*4
390 GOTO 410
400 PLOT X1,Y1:DRAWTO X1+XVEC,Y1+YVEC:D
RAWTO X1+XVEC,Y1+YVEC*4:DRAWTO X1,Y1+YV
EC*5
410 ON DIR GOTO 420,430,440,450
420 XL=X+1:YL=Y+1:GOTO 460
430 XL=X+1:YL=Y-1:GOTO 460
440 XL=X-1:YL=Y-1:GOTO 460
450 XL=X-1:YL=Y+1
460 IF A(XL,YL)=0 THEN 490
470 PLOT 319-X1,Y1+YVEC:DRAWTO 319-X1-X
VEC,Y1+YVEC:DRAWTO 319-X1-XVEC,Y1+YVEC*
4:DRAWTO 319-X1,Y1+YVEC*4
480 GOTO 500
490 PLOT 319-X1,Y1:DRAWTO 319-X1-XVEC,Y
1+YVEC:DRAWTO 319-X1-XVEC,Y1+YVEC*4:DR
AWTO 319-X1,Y1+YVEC*5
500 X1=X1+XVEC:Y1=Y1+YVEC:XVEC=XVEC/2:Y
VEC=YVEC*0.6
510 XL=X+(DIR=2)*(I+1)-(DIR=4)*(I+1):YL
=Y+(DIR=1)*(I+1)-(DIR=3)*(I+1)
520 IF I<9 AND A(XL,YL)>0 THEN I=I+1:GO
TO 320
530 IF A(XL,YL)>0 THEN RETURN
540 PLOT X1,Y1:DRAWTO 319-X1,Y1:PLOT X1
,160-Y1:DRAWTO 319-X1,160-Y1
550 RETURN
560 NAME2$="D:"
565 REM *** OLD LEVEL ? ***
570 GRAPHICS 0:SETCOLOR 2,0,0:POSITION
15,0:? "Doorwarden.":? :?
5.0:? "Doorwarden.":? :?
580 ? "Do you wish to enter a saved lev
el ";:GET #1,K
590 IF K=78 THEN 690
600 IF K<>89 THEN 570
610 ? :? "Name of this stored level ";:
INPUT GEN$
620 NAME2$(3)=GEN$
630 TRAP 650
640 OPEN #2,4,0,NAME2$:GOTO 660
650 CLOSE #2:GOTO 610
660 FOR I=1 TO 20:FOR J=1 TO 20:INPUT #
2;Z:A(I,J)=Z:NEXT J:NEXT I
670 INPUT #2;X:INPUT #2;Y:INPUT #2;DIR:
CLOSE #2
680 TRAP 40000:GOTO 770
684 REM *** ULTRA COMPLEX MAZE ***
686 REM *** GENERATOR!!! ***
690 ? CHR$(125):POKE 752,1:POSITION 16,
0:? "WAIT":Z=320
700 FOR I=1 TO 20:A(I,1)=0:A(I,20)=0:A(2
0,1)=0:A(1,1)=0:NEXT I
710 FOR I=2 TO 19:FOR J=2 TO 19:POSITIO
N 21,0:? Z;" " :Z=Z-1
720 X=INT(RND(1)*14):IF X>9 THEN X=0
730 IF X<>0 AND RND(1)<0.75 THEN X=1
740 A(I,J)=X:NEXT J:NEXT I
750 X=INT(RND(1)*17)+2:Y=INT(RND(1)*17)
+2:DIR=INT(RND(1)*4)+1:IF A(X,Y+1)<>1 T
HEN 750
760 A(X,Y)=9
765 REM *** RE-ENTRY POINT ALWAYS ***
770 GRAPHICS 8:SETCOLOR 2,0,0:COLOR 15:
IF A(X,Y)<>5 THEN GOSUB 310
780 ? CHR$(125):POKE 752,1
790 ? " W STRENGTH ";5T2;" DEXTERIT
Y ";DEX2;" "
800 ? "A D HIT PTS ";HP2;" TREASURE
";GD
810 GET #1,K
815 REM *** IF TURN, DO IT ***
820 IF K=A5C("A") THEN DIR=DIR-1:DIR=DI
R+(DIR=0)*4:GOTO 770

```

```

830 IF K=A5C("D") THEN DIR=DIR+1:DIR=DI
R-(DIR=5)*4:GOTO 770
840 IF K<>A5C("W") THEN 810
850 XL=X+(DIR=2)-(DIR=4):YL=Y+(DIR=1)-(
DIR=3)
855 REM *** HIT A WALL, TWIT! ***
860 IF A(XL,YL)=0 THEN ? CHR$(125);"
OUCH!":? CHR$(259):FOR I
=1 TO 500:NEXT I:GOTO 780
870 X=XL:Y=YL
880 IF A(X,Y)=1 OR A(X,Y)=3 THEN 770
890 IF A(X,Y)<4 THEN 960
895 REM *** NIT FALLS DOWN HOLE! ***
900 ? CHR$(125);" *** A PIT!
***"
910 FOR I=0 TO 255:SOUND 0,I,10,15-INT(
I/16):NEXT I
920 ST2=5T2-INT(RND(1)*5)+1:HP2=HP2-INT
(RND(1)*9):IF ST2<0 THEN ST2=0
930 FOR I=1 TO 500:NEXT I
940 IF HP2<0 THEN 2210
950 GOTO 770
955 REM *** I FEEL DIZZY... ***
960 IF A(X,Y)<>8 THEN 980
970 DIR=INT(RND(1)*4)+1:GOTO 770
980 IF A(X,Y)<>9 THEN 1250
985 REM *** YIPPEEE! WAY OUT. ***
990 ? CHR$(125);"Stairway out.Do you wi
sh to leave Y/N";:GET #1,K
1000 IF K<>89 AND K<>78 THEN 990
1010 IF K=78 THEN 770
1020 GRAPHICS 0:SETCOLOR 2,0,0:? "YOU 5
URVIVED!"
1030 ? :? :? "Current gold is ";GD
1040 ? :? "Current experience is ";XP
1050 XPE=100:IF LV=1 THEN 1070
1060 FOR I=1 TO LV-1:XPE=XPE+XPE:NEXT I
1070 IF XP>XPE THEN LV=LV+1:XP=0:HP=HP+
INT(RND(1)*10)*LV:? :? "You have made i
t to level ";LV
1080 ? :? "Rating is ";
1090 Z=INT(XP/1000):IF Z>10 THEN ? "TOO
GOOD!":GOTO 1110
1100 ? RATE$(2*10+1,Z*10+10)
1110 POSITION 2,23:? "PRESS [RETURN]";:
GET #1,K
1120 GRAPHICS 0:SETCOLOR 2,0,0:POSITION
15,0:? "Doorwarden.":? :?
1130 ? "Do you wish to save this level
";:GET #1,K
1140 IF K<>89 AND K<>78 THEN 1120
1150 IF K<>89 THEN 1210
1160 ? :? "Name of this stored level ";:
INPUT GEN$
1170 NAME2$(3)=GEN$
1180 OPEN #2,8,0,NAME2$
1190 FOR I=1 TO 20:FOR J=1 TO 20:Z=A(I,
J):PRINT #2;Z:NEXT J:NEXT I
1200 PRINT #2;X:PRINT #2;Y:PRINT #2;DIR
:CLOSE #2
1205 REM *** DUMP CHARACTER ***
1210 ? CHR$(125):NAME2$(3)=NAME2$(3)=
NAME$:OPEN #2,8,0,NAME2$
1220 PRINT #2;ST:PRINT #2;DEX:PRINT #2;
LK:PRINT #2;HP:PRINT #2;LV:PRINT #2;XP:
PRINT #2;WP
1230 PRINT #2;SP:PRINT #2;SH:PRINT #2;
PO:PRINT #2;5P:PRINT #2;GD:PRINT #2;PO:
CLOSE #2
1240 RUN "D:CASTLE.BAS"
1245 REM *** HELLO,WHAT'S THIS ? ***
1250 IF A(X,Y)<>7 THEN 1430
1260 A(X,Y)=1:RESTORE 1940:Z=INT(RND(1)
*INT(XP/1000)):IF Z>9 THEN 1260
1270 FOR I=1 TO Z:READ NAME2$,TGP,MAG,5
TU,DUX:NEXT I
1280 ? CHR$(125);"You have found ";NAME
2$;:IF TGP>0 THEN ? " worth ";TGP;" GP"
:GP=GP+TGP
1290 ? :IF MAG>0 THEN ? "You gain magic
al ability";5P=5P+INT(RND(1)*LK):IF 5P>
4 THEN 5P=4
1300 IF STU>0 THEN ? "You feel stronger
";5T2=5T2+INT(RND(1)*(X/1000))
1310 IF DUX>0 THEN ? "Your armour feels
weightless.":DEX=DEX+INT(RND(1)*(5T/10
))
1320 ? "Press [RETURN]";:GET #1,K
1330 GOTO 770
1334 REM *** LIST OF OBJECTS-CAN ***
1336 REM *** BE EXTENDED BY YOU ***

```

# ATARI PROGRAM

```

1940 DATA Magic Scrolls,0,1,0,0
1950 DATA Loose Coins,2,0,0,0
1960 DATA A Green Potion,0,0,1,0
1970 DATA A Blue Potion,0,0,0,1
1980 DATA A Ring,3,1,0,0
1990 DATA A Carved Figure,2,0,0,0
1400 DATA Gemstones,4,0,0,0
1410 DATA Fragrant oils,0,0,1,1
1420 DATA A rod,0,1,0,1
1424 REM *** ULP! WHAT'S THAT ***
1426 REM *** DARK,NASTY SHADOW? ***
1430 GRAPHICS 0:SETCOLOR 2,0,0:POKE 752
.1
1440 TGP=INT(RND(1)*(LV/2))+INT(RND(1)*
3):IF TGP<1 THEN TGP=1
1450 IF TGP>6 THEN TGP=6
1460 TGP2=TGP:GOLD=0:XPE=0
1470 FOR I=0 TO TGP-1:MONS=INT(RND(1)*L
V)+1+INT(RND(1)*2):IF MONS>10 THEN MONS
=10
1480 RESTORE 2180:GOLD=GOLD+INT(RND(1)*
(MONS)):XPE=XPE+MONS*50
1490 FOR J=1 TO MONS:READ STU:STU(I+1)=
STU:READ DUX:DUX(I+1)=DUX:READ MAG:MAG
(I+1)=MAG:READ HIP:HIP(I+1)=HIP
1500 NEXT J:MONS=MONS-1:NAME2$(I*10+1,I
*10+10)=MONS$(MONS*10+1,MONS*10+10):NEX
T I
1510 ? "You Have Come Upon : "
1520 POSITION 2,2: ? "GROUP NAME STA
TUS"
1530 FOR I=0 TO TGP-1: ? " ;I+1;" "
;NAME2$(I*10+1,I*10+10);:POSITION 18,I+
3:IF HIP(I+1)>0 THEN ? "ALIVE "
1540 IF HIP(I+1)<=0 THEN ? "DEAD "
1550 NEXT I
1560 IF RND(1)>0.65 THEN POSITION 2,20:
? "The Enemy Have The Advantage...":GOTO
1930
1570 POSITION 2,20: ? "Your Options : 1)
FIGHT 2) WITHDRAW":POSITION 17,21: ? "3
) SPELL 4) BARGAIN"
1580 POSITION 17,22: ? "5) DRINK POTION"
1590 POSITION 2,29: ? "Your Option ";:GE
T #1,K
1600 IF K<49 OR K>59 THEN 1590
1610 POSITION 0,20:FOR I=1 TO 15: ? "
";:NEXT I
1620 K=K-48:ON K GOTO 1830,1810,1720,16
60,1690
1625 REM *** MAGIC POTION! ***
1630 IF P0=0 THEN 1940
1640 HP2=HP2+INT(RND(1)*10)+1:IF HP2>HP
THEN HP2=HP
1650 GOTO 1940
1654 REM *** LOOK GUYS,CAN'T WE ***
1656 REM *** MAKE A DEAL ?? ***
1660 IF LV/10>RND(1) THEN 1940
1670 DAM=INT(RND(1)*5)*TGP2+1:IF DAM>GD
THEN 1940
1680 POSITION 2,20: ? "You May Pass For
";DAM;" Gp.Y/N";
1690 GET #1,K:IF K>89 AND K<78 THEN 1
690
1700 IF K=89 THEN GD=GD-DAM:GOTO 770
1710 GOTO 1940
1715 REM *** ZAPPEM!! ***
1720 POSITION 2,20: ? "Which Spell (1-4)
";
1730 GET #1,K:K=K-48:IF K<1 OR K>4 THEN
1730
1740 IF 5P<K OR RND(1)>0.9 THEN 5P=0:GD
TO 1930
1750 5P=5P-K:IF 5P=1 THEN I=INT(RND(1)*
TGP)+1:HIP(I)=HIP(I)-INT(RND(1)*4)+1:GD
TO 1930
1760 IF 5=2 THEN I=INT(RND(1)*TGP)+1:HI
P(I)=INT(RND(1)*4)+1:GOTO 1930
1770 I=INT(RND(1)*3)-1:J=INT(RND(1)*3)-
1:A(X+I,Y+J)=1:GOTO 770
1780 X=INT(RND(1)*17)+2:Y=INT(RND(1)*17
)+2:IF A(X,Y)<1 THEN 1780
1790 GRAPHICS 2:SETCOLOR 2,0,0:POKE 752
.1:POSITION 9,6: ? #6;"GO!"
1800 FOR I=255 TO 0 STEP -1:SOUND 0,I,8
.8:NEXT I:SOUND 0,0,0:GOTO 770
1810 IF RND(1)>0.7 THEN POSITION 2,20:F
OR I=1 TO 10: ? " ";:NEXT I:
GOTO 1930
1820 GOTO 770
1824 REM *** THE FOOL'S TRYING ***

```

```

1826 REM *** TO FIGHT IT OUT! ***
1830 POSITION 2,21: ? "Against Which Gro
up ";:GET #1,K
1840 K=K-48:IF K<1 OR K>TGP OR HIP(K)<=
0 THEN 1830
1850 POSITION 2,20:FOR I=1 TO 10: ? "
";:NEXT I
1860 DAM=INT(RND(1)*100)+INT(XP/1000)
1870 IF DAM<DUX(K) THEN POSITION 2,20: ?
"Your Stroke Goes Wide!":FOR I=1 TO 20
0:NEXT I:GOTO 1930
1880 DAM=INT(RND(1)*100)
1890 IF DAM<STU(K) THEN POSITION 2,20: ?
"THE ";:NAME2$(K-1)*10+1,(K-1)*10+10);
" Defends!":GOTO 1930
1900 DAM=INT(RND(1)*WP*2*LV)+1:DAM=DAM+
(WP=6)+(WP=7):DAM=DAM+(WP=7 AND RND(1)
0.95)*100+(WP=8)*DAM
1910 POSITION 2,21: ? "You Strike For ";
DAM;" points!":HIP(K)=HIP(K)-DAM
1920 IF HIP(K)<=0 THEN POSITION 2,22: ?
"The ";:NAME2$(K-1)*10+1,(K-1)*10+10);"
is dead!":TGP2=TGP2-1
1930 FOR I=1 TO 150:NEXT I
1940 POSITION 0,20:FOR I=1 TO 15: ? "
";:NEXT I
1950 IF TGP2=0 THEN GOTO 2120
1960 FOR I=0 TO TGP-1:IF HIP(I+1)<=0 TH
EN 2100
1970 DAM=INT(RND(1)*100)
1980 POSITION 2,20: ? "The ";:NAME2$(I*10
+1,I*10+10);" strikes...";
1990 IF RND(1)<0.75 OR MAG(I)=0 THEN 20
40
2000 ? "with a thunderbolt!":FOR J=1 TO
150:NEXT J
2010 DAM=INT(RND(1)*MAG(I))+1:MAG(I)=MA
G(I)-DAM:HP2=HP2-DAM
2020 IF HP2<=0 THEN 2210
2030 POSITION 2,20:FOR I=1 TO 5: ? "
";:NEXT I:GOTO 2110
2040 HPB=INT(DEX2/10)+ARM*4:IF DAM<=HPB
THEN ? "but misses!":FOR J=1 TO 100:N
EXT J:GOTO 2100
2050 IF RND(1)*100+LV*4<5T2 THEN ? "you
defend!":FOR J=1 TO 100:NEXT J:GOTO 21
00
2060 DAM=INT(RND(1)*(STU(I+1)/5))+1:DAM
=DAM-INT(RND(1)*(ARM*2)):IF DAM<1 THEN
DAM=1
2065 REM *** OWWWWWWWWWW!! ***
2070 ? "and hits for ";DAM;" points!"
2080 FOR J=1 TO 150:NEXT J
2090 HP2=HP2-DAM:IF HP2<=0 THEN GOTO 22
10
2100 POSITION 0,20:FOR J=1 TO 15: ? "
";:NEXT J
2110 NEXT I:GOTO 1520
2114 REM *** CAN I OPEN MY EYES ***
2116 REM *** NOW ? ***
2120 ? CHR$(125);:POSITION 13,0: ? "You
Survived!"
2130 ? : ? ? "Searching the bodies of t
he fallen"
2140 ? "reveals ";:GOLD;" gold pieces!";
:GD=GD+GOLD
2150 ? : ? "Experience points gained ";:X
PE:XP=XP+XPE
2160 POSITION 2,21: ? "PRESS [RETURN]";:
GET #1,K
2170 A(X,Y)=1:GOTO 770
2175 REM *** MONSTER ATTRIBUTES ***
2180 DATA 10,8,0,3,16,20,0,6,5,8,10,4
2190 DATA 30,18,0,12,50,10,0,20,60,40,2
0,26
2200 DATA 64,56,34,31,85,86,49,49,89,37
,65,66,95,45,75,86
2204 REM *** ABANDON HOPE ALL YE ***
2206 REM *** WHO ENTER HERE. ***
2210 GRAPHICS 0:SETCOLOR 2,0,0:POKE 752
.1:POSITION 18,10: ? "DEAD"
2220 POSITION INT((40-LEN(NAME$))/2),12
: ? NAME$
2230 COLOR 160:PLOT 19,14:DRAWTO 19,20:
DRAWTO 20,20:DRAWTO 20,14
2240 PLOT 16,16:DRAWTO 23,16:COLOR 32:P
LOT 0,0
2250 X10 33,#2,0,0,"D:NAME.DAT"
2260 NAME2$="D":NAME2$(3)=NAME$:X10 33
.#2,0,0,NAME2$
2270 POSITION 2,0:POKE 752,0:END

```

# sinclair special

6



*Inside...*

*Setting new standards in  
educational software with  
Sinclair-Macmillan*

*Plus six other learning programs*

# TODAY, LEARNING IS A NEW GAME

Subsidised microcomputers are now commonplace as teaching aids for the very youngest children and the ZX Spectrum is prominent amongst those micros at use in schools.

In the relatively short time that the Spectrum has been at work in the classroom, two questions have been answered. Yes: with the right software, the micro can and does teach effectively and thoroughly (and gives teachers more time to devote to individual pupils). Yes: young children think little of working rapidly and successfully, with a screen and keyboard, on even quite complex subjects.

In this Sinclair Special we reveal a range of educational software specifically designed to make full use of these advantages. The programs produced by Sinclair in collaboration with Macmillan Education are fascinating. They deal imaginatively and most effectively with early reading skills and take a truly refreshing approach to basic science.

In the Blackboard range we've programs which bring a light-hearted clarity to the tricky matters of spelling and punctuation.

These programs are designed for use both at home and in the classroom. Each program is accompanied by full documentation which gives parents helpful advice and guidance on the educational objectives.

The programs covered on these pages represent only a fraction of the full and fast-growing list of Spectrum software. Be assured we'll keep you in touch with new developments as they happen.

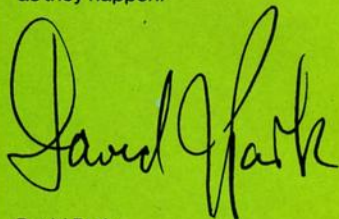

David Park  
Education Marketing Manager

# NEW WAYS TO LEARN WITH THE ZX SPECTRUM<sup>™</sup>

## Programs from Blackboard Software

The new range of educational programs from Blackboard Software makes learning an enjoyable process by involving the child in a game which teaches as it entertains.

Each program has a step-by-step example section and gives correct answers after a number of attempts. Vocabulary changes can be made, allowing each program to keep pace with the child's development. This flexibility can also be used in the classroom to cater for children of differing ability.

The instructive and colourful games which follow the successful completion of each group of sentences provide useful practice in letter recognition and increase familiarity with the Spectrum keyboard.

All programs are written for the 48K RAM Spectrum.



### Alphabet Games

Three games of letter recognition (using either upper or lower case) to help children learn the alphabet and find their way round the computer keyboard.

**Alphagaps** — The full alphabet is displayed, along with a second, incomplete version. The child must fill in the missing letters.

**Random Rats** — Press the letter key that is displayed on the gun to destroy the rats which have invaded the cellar!

**Invaders** — Stop little green men from landing on Earth by pressing the appropriate letter.

### Early Punctuation

While an animated matchstick man marches above displayed sentences the child must decide which punctuation mark is missing and where to insert it. At the touch of a key the matchstick man drops the mark into place. After successful completion of every sentence in the exercise, light relief comes in the form of a bottle-shooting game!

### The Apostrophe

As each sentence is displayed, a bird appears with a worm in its beak. The keyboard is used to move the bird and drop the worm into the correct place for the apostrophe. When ten sentences have been corrected, the Grub Game is displayed. Press the correct character to change the grub into a butterfly...before it munches through a flower!

### Capital Letters

A program to teach the use of capital letters. Sentences incorporating proper nouns and sentences without opening capitals are displayed. The child inserts the correction by guiding an animated figure to the appropriate letter.

For each correct answer an apple grows on a tree. After ten correct answers the child's skills in recognising letters and using the Spectrum keyboard are needed to save the apples as they fall to the ground.

### Speech Marks

A comprehensive program including sentences with one or two sets of speech marks ("inverted commas") and exercises in both direct and reported speech.

Using the Spectrum keyboard, a cursor is used to guide speech marks to the correct position. The program offers three levels of difficulty, with full examples for each section. Guide Max the mouse through a maze, after the correct completion of five sentences from each section, but beware of Persian cats!

### Castle Spellerous

A spelling game with ten levels of vocabulary, including words with silent first letters, double letters and other difficult words. The Princess has been captured and carried off to Castle Spellerous. Helped by ten soldiers, the child can attempt a rescue by giving the right answers. Part of a siege tower is built for each correctly spelt word. Mistakes are costly — the wicked wizard appears as a vampire bat, turning the men into frogs, butterflies and bats!

When ten words are spelt correctly the rescue begins and the wizard takes flight.



# SINCLAIR + MACMILLAN: A NEW DIMENSION IN EDUCATIONAL PROGRAMS

Sinclair have joined forces with Macmillan Education to produce a completely new and different range of educational software. The results so far can be seen in these exceptional programs.

The Learn to Read series is derived from Macmillan Education's best-selling primary school reading scheme, Gay Way. It offers a unique opportunity for parents and

teachers to participate in the child's first experience in reading.

Macmillan Education's Science Horizons is one of Britain's most successful school science schemes. Each program concentrates on key scientific ideas and, through simulation of real life, makes the learning process entertaining and enjoyable.



## Learn to Read 1

Learn to Read 1 is designed for children who are just beginning to read. It is in four parts, each of which develops skills central to the reading process — letter recognition, sight vocabulary, early spelling and memory. The program is full of colour and fun and children will enjoy learning to read as they meet the animal characters — Ben the dog, Jip the cat and their friends.

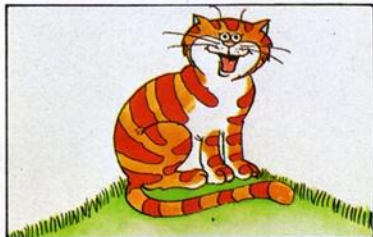

## Learn to Read 2

Learn to Read 2 extends the fundamental reading skills practised in the first program, as well as encouraging logical thinking. The child's vocabulary is gradually built up as new words such as "red," "green," "car," "ship" and "bus" are introduced. In addition, Learn to Read 2 features an attractive 'reward' system enabling children to see their achievements grow.

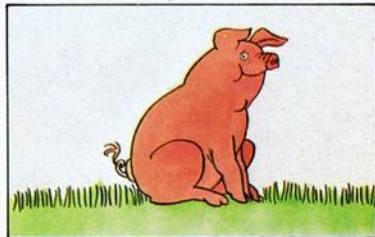

## Learn to Read 3

Learn to Read 3 builds on the child's progress so far, so that he or she can gain the confidence to move on through the complex reading process. Learn to Read 3 features four different activities, all of which are colourful and lively. Further vocabulary is introduced until the child is reading more than 30 words.



## Learn to Read 4

Learn to Read 4 is the alphabet program in the Learn to Read series.

Using various stimulating activities the program gives the child plenty of practice in working with the alphabet — matching initial letters to words and pictures and spotting missing letters. These exercises build familiarity with simple sequences within the alphabet.

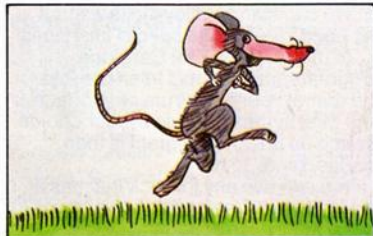

## Learn to Read 5

Learn to Read 5 teaches positional language — often difficult to understand and remember — by using words and phrases such as "behind" and "in front of," "inside" and "outside."

The program first demonstrates the meanings of the words using clear pictures. It then tests the child's understanding of the words in two lively games.



## Cargo

Set sail around the world. Choose your ports of call — New York, Tokyo, Belem, Helsinki — then the real challenge begins! You must reach your destinations safely, weathering storms on the way. But first, load your cargo — using all your knowledge and skill. Poor loading can mean capsizing and sinking. Your rank, if not your life, is always at stake!



## Glider

Be a glider pilot! The glider models real-life gliding conditions so that you can learn through experience. As the pilot you must consider the time of day, the amount of cloud cover and the kind of terrain below you in order to find the up-currents of air that will keep you airborne. Try to fly as far as possible and, when you are high enough, navigate your way back to your home airfield and land safely — if you can.



## Survival

Discover what it is like to be an animal in the wild! Be a lion stalking your prey, escaping human hunters. Or be a hawk, mouse or even a butterfly, searching for food and avoiding predators.

Survival models the natural world and brings to life hazards that different creatures must face in their struggle to stay alive.



## Magnets

With an army of small magnets you set out to conquer the powerful supermagnets of your opponent. You have one weapon — your forces of magnetic attraction and repulsion.

The strategy is simple: attract smaller magnets to build strength to repel the super-magnet. When cornered, just turn your poles on your enemy and see what happens!

# ZX INTERFACE 2

## THE NEW ROM CARTRIDGE AND JOYSTICK INTERFACE

Now available in shops



**Loads programs instantly**  
**Takes two joysticks**  
**Just plug-in and play**

The ZX Interface 2 is the latest new peripheral for the ZX Spectrum system. It enables you to use new ZX ROM cartridge software: plug-in programs that load instantly. There are ten terrific games already available on cartridge. ZX Interface 2 also allows you to use

one or two standard joysticks without the need for separate special interfaces.

To use new ZX ROM Cartridge programs, just connect Interface 2 to the rear of your Spectrum or Interface 1 and plug in the cartridge of your choice. Switch on and the program is then loaded, ready to run!

You can use any joystick that has a 9-way D plug. Use one or two of them for extra fun with suitable ZX ROM cartridge or Sinclair cassette programs – or with dozens of other Spectrum programs.

## ZX MICRODRIVE/ ZX INTERFACE 1

The ZX Microdrive System is unique. This compact, expandable add-on system provides high-speed access to massive data storage. With just one Microdrive and a ZX Interface 1 you'll have at least 85K bytes of storage, the ability to LOAD and SAVE in a matter of seconds, the beginnings of a local area network of up to 64 Spectrums and a built-in RS232 interface. The cost? Less than £80.

### How to get ZX Microdrive and ZX Interface™ 1

Spectrum owners who bought direct from us by mail order have been sent full details. Order forms are being mailed in strict rotation. If you haven't yet received your order form please bear with us. We're making good progress in meeting the huge demand.

If you didn't buy your Spectrum by mail order, send us the form at the bottom of this page and we'll add your name to the mailing list.

### How to order

Complete the appropriate sections on the order form below. Note that there is no postage or packing to pay on software purchases. Orders may be sent FREEPOST (no stamp needed). Credit card holders may order by phone, calling 01-200 0200, 24 hours a day. Please allow 28 days for delivery.

© Sinclair, ZX Spectrum, ZX Microdrive, ZX, ZX Interface are trade marks of Sinclair Research Ltd.

# sinclair™

Sinclair Research Ltd, Stanhope Road, Camberley, Surrey, GU15 3PS. Telephone: (0276) 685311.

To: Sinclair Research Ltd, FREEPOST, Camberley, Surrey, GU15 3BR.

#### Section A: Hardware

Qty	Item	Code	Item Price £	Total £
	ZX Interface 2	8501	19.95	
	ZX Spectrum – 48K	3000	129.95	
	ZX Spectrum – 16K	3002	99.95	
	Postage and packing: orders under £90	0028	2.95	
	orders over £90	0029	4.95	
			<b>TOTAL £</b>	

#### Section B: Software

	E10/S Learn to Read 1	4309	9.95	
	E11/S Learn to Read 2	4310	9.95	
	E12/S Learn to Read 3	4311	9.95	
	E13/S Learn to Read 4	4312	9.95	
	E14/S Learn to Read 5	4313	9.95	
	E15/S Cargo	4314	9.95	
	E16/S Glider	4315	9.95	
	E17/S Survival	4316	9.95	
	E18/S Magnets	4317	9.95	
	E19/S Early Punctuation	4318	7.95	

#### ORDER FORM

E20/S Speech Marks	4319	7.95
E21/S Apostrophe	4320	7.95
E22/S Capital Letters	4321	7.95
E23/S Castle Spellerous	4322	7.95
E24/S Alphabet Games	4323	7.95
		<b>TOTAL £</b>

\*I enclose a cheque/postal order made payable to Sinclair Research Ltd for £

\*Please charge my Access/Barclaycard/Trustcard account no:

\*Delete/complete as applicable.

Signature \_\_\_\_\_

Mr/Mrs/Miss \_\_\_\_\_

Address \_\_\_\_\_

\_\_\_\_\_

\_\_\_\_\_

HCW 912  
(Please print)

### ZX Microdrive™ information request

Please add my name to the Microdrive Mailing List and send me a colour brochure with full specifications of ZX Microdrive/Interface 1  (tick here).

### Free Sinclair ZX™ Software Catalogue

Please reserve my priority copy of the January 1984 Sinclair ZX Spectrum Software Catalogue  (tick here).

Please use the form above to send your name and address.

# NATIONWIDE SHOPS & DEALERS

## CAMBRIDGESHIRE



Computer Software Specialists  
at **JUST VIDEO**  
Fitzwilliam Street  
Peterborough  
Tel: Pet. 310554

## CORNWALL

### FAL-SOFT COMPUTERS

8 St. Georges Arcade, Falmouth,  
Cornwall. Tel: 0326 314663.  
We are stockists of BBC, Sinclair,  
Commodore, Dragon, Oric, Colour Genie,  
MPS-2 and Comex-35.

## ESSEX

**BBC ★  
SPECTRUM ★ TEXAS**  
Extensive range of  
software/hardware/books always in  
stock.  
**ESTUARY SOFTWARE PRODUCTS**  
261, Victoria Avenue, SOUTHEAD,  
Essex. Tel: 0702 43568.

## HERTFORDSHIRE



Computer Software Specialists  
at **VIDEO CITY**  
45/47 Fisher's Green Road  
Tel: Stevenage 353808



Computer Software Specialists  
at **DJ RECORDS**  
16 High Street  
Hitchin  
Tel: Hitchin 56805

## KENT

### ROCHESTER SOFTWARE & COMPUTER CENTRE

Open  
27th, 28th, 29th December  
and New Years Day  
All makes of computers, books  
and software.  
Access/Barclay Card welcome at:  
38, Delce Road, Rochester, Kent.  
Tel: 0634 408305.

## COMPUTER BARGAINS

**LIMITED PERIOD ONLY**  
ORIC 16K - £89 (save £10)  
ORIC 48K - £134 (save £5)  
DRAGON 32K - £170 (save £5)  
COMMODORE Disc Drive -  
£219 (save £10) PLUS  
incl. £105 FREE Software.  
Plus other computers, software  
and peripherals etc.

**COMPUTER WORLD**  
208 Kent House Road,  
Beckenham, Kent  
Tel: 01-853 3307 after 8pm

## LANCASHIRE

**LEIGH COLOUR  
LABORATORY LTD.**  
87 Chapel St, LEIGH, Lancs.  
Tel: Leigh (0942) 607661

Open: Monday - Friday 9.00 - 5.30  
and most Saturdays 10.00 - 4.00.  
- Be Wise, Use The Specialists -

## SOMERSET

### PHOENIX SOFTWARE CENTRE

A large range of software in stock for  
ATARI, BBC, DRAGON, ORIC-1,  
SPECTRUM, COM 64 & VIC-20.  
Also stockists of BBC &  
SPECTRUM COMPUTERS.  
Open Mon - Sat 9am - 6pm.  
Access & Barclaycard accepted.

88 Huish, Yeovil, Somerset  
Tel: (0935) 21724

### HCW YOUR SOFTWARE SUPERMARKET.

## STAFFS

24 The Parade  
Silverdale, Newcastle  
Tel. 0782 636911  
**Official dealers for  
Commodore, Sinclair, &  
Acorn. BBC service and  
information centre**  
Huge range of hardware and  
software backed up by  
sophisticated service department

## Computarama - The Midlands/ Home Computer Specialists

**FOR BBC, SPECTRUM &  
ALL LEADING MICRO'S**  
STAFFORD: 59 FOREGATE ST  
TEL: 0785 41899

**STOKE-ON-TRENT:**  
MARKET SQUARE ARCADE  
TEL: 0782 268620

### HCW — COMPATIBLE WITH ALL POPULAR HOME COMPUTERS.

## LONDON

### DAVID SHACK SOFTWARE

Over 150 games for the Spectrum and  
100 for the VIC-20. Also BBC, CBM  
64, Dragon, Atari, software sold at  
discount prices. SAE for lists to:  
294 Romford Road,  
Forest Gate E7. Tel: 01-555 9303

### CHRISTMAS SPECIAL OFFERS

- Quickshot joysticks: £8.50
  - Program data recorders: £23
  - BBC Model B: £399.95  
(with FREE tape recorder)
- All prices inclusive of VAT and  
p&p. Cheques/POs crossed,  
payable to: 'JAYSONS'

**JAYSONS**  
20 Chessington Ave,  
London  
Tel: 01-349 3638/2498  
TRADE ENQUIRIES WELCOME

### ARMCHAIR ACTION COMPUTERS BEAT THESE PRICES

VIC-20 KIT £135  
Commodore 64 £198  
Commodore 1541 Disc Drive £209  
Spectrum 16K £97. Spectrum 48K £127  
Large range of software available for any of the above machines plus Oric,  
Dragon & BBC.  
Open Monday - Saturday 10am - 5.40pm (5 pm Wednesday)  
Contact Armchair Action at: 41 Drayton Green Road, Ealing, London W13  
(next to West Ealing Station). Tel: 01-567 1944

## SUSSEX

Sussex Computer Centre  
39 High Street  
**LITTLEHAMPTON**  
West Sussex Tel: 5674  
We are stockists of Sinclair, VIC, Atari,  
Dragon, Oric, Lynx, Sharp, Colour Genie  
and Texas Instruments.  
Members of Spectrum Discount Group.

### The Micro Store HOME COMPUTER CENTRE

We carry a large selection of  
hardware/software/accessories  
for BBC, ORIC, SPECTRUM,  
CBM 64, VIC-20, ATARI 400,  
600 & 800, DRAGON &  
MEMOTECH.  
13B West Street,  
Horsham, W. Sussex  
Tel: 0403 52297

## SCOTLAND

**THE GAMES SHOP AND  
COMPUTER SOFTWARE  
CENTRE TEL. NO. 0224-643740**  
3 Waverley Place, Aberdeen AB1 1XH.  
Stockists of Spectrum, Dragon, VIC-20  
and Commodore 64 software. Extensive  
selection of books and magazines.

**PLEASE NOTE THAT  
WE ARE MOVING TO  
NEW OFFICE  
PREMISES ON  
MONDAY 19th  
DECEMBER. WRITE  
TO 1 GOLDEN  
SQUARE, LONDON  
W1 OR TELEPHONE  
01-437 0699 TO  
BOOK YOUR  
ADVERTISEMENT  
SPACE.**

Please include my business details in the next available issue of Home Computing Weekly

Business Name: .....

Address: .....

Tel. No.: .....

Open Hrs: .....

Contact (Office Use Only): .....

Post To: H.C.W. (Shops & Dealers), 145 Charing Cross Rd., London WC2H 0EE.



# HOME COMPUTING WEEKLY CLASSIFIED

Lineage:  
35p per word



01-437 1002  
EXT 211.

Send your requirements to:  
**Debra Stuppel**  
**ASP LTD.**  
145 Charing Cross Road,  
London WC2H 0EE

Semi display: £6.00 per single column centimetre  
Ring for information on series bookings/discounts.

All advertisements in this section must be prepaid.  
Advertisements are accepted subject to the terms and  
conditions printed on the advertisement rate card (available on request).

## ACCESSORIES

UNIT  
ONLY

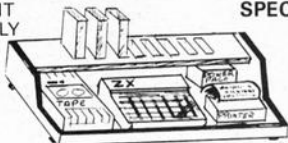

**SPECTRUM & ZX 80/1**  
USERS  
LOOK THIS  
WAY  
PUT AWAY  
ALL THOSE  
UNTIDY  
WIRES

With this amazing new unit designed by a Spectrum user. Put on a chair, floor, on your lap. Move it all in one go. Made of polished Mahogany, ply or black. (State colour) at £23.50 inc. VAT & p&p. Send cheque, P/O to:

E. R. Cameron & Son Ltd. Est. 1870  
H/O 9 The Vineries, Enfield, Middx. EN1 9DQ

**LYNX LYNX LYNX**  
COMPLETE KEYBOARD PACKAGE OF  
A DATA STAND PLUS DATA CARDS  
• Quality DATA STANDS to help in typing in programs  
• DATA CARDS contain full keyboard information  
• Keyboard entry of user defined graphic characters.  
• Also a new approach to number conversion.  
Avoid those '0's & '1's. BPP  
Dealers enquiries welcome. **£14.95** inclusive  
Cheques & PO's only. Please allow 28 days for delivery.

**PERIPHERAL PRODUCTS**  
209 KENTON LANE,  
KENTON, MIDDX.  
Tel: 01-907 3406

## PREVENT TAPE LOADING ERRORS!

### SPECIAL COMPUTER CASSETTE RECORDER

- Spectrum, Dragon, Acorn, ZX-81 etc.
- Correct output level Led's.
- Individually tested and aligned to suit your computer type.
- Tape counter • BEEP Amp option.
- No need to remove leads to load or save (even on ZX + Spectrum).
- Only £29.95 inc. VAT includes FREE cleaning kit. p&p £2.25.

A. W. HEADEN LTD 218 High St.  
Potters Bar, Herts. 0707 52688

Dust Covers available for any computer printer, etc. BBC, TI, Epson £3.95. Dragon, Atari, VIC-20 £2.95. Sharp MZ-80A-K, £4.95, for others please phone or write to: Sherborne Designs, 15B Chemical Road, West Wilts Trading Estate, Westbury, Wilts. Tel: 02214 4425. Also made-to-measure service. Dealer enquiries welcome. Access and Barclaycard.

Keep it Clean. Maintain the high performance of your micro with the micro maintenance kit, approved by I.B.M., 3M, etc. Call Screen Care 01-654 9538.

**ALL YOUR COMPUTER  
NEEDS** from our **FREE**  
COMPREHENSIVE CATALOGUE OF  
MICROCOMPUTER ACCESSORIES  
and SOFTWARE  
sae please to:  
'Freepost' ALLCOM  
20 Harwood Road, Lichfield.  
Staffs WS13 6BR

## ZX OWNERS BANISH LOADING PROBLEMS

Send S.A.E for Leaflet.  
STATE ZX81 or SPECTRUM.

**ELINCA PRODUCTS LTD.**  
Lyon Works, Capel Street,  
Sheffield 6. (tel 0742 339774)



for only

**£14.99**  
Inc. VAT - Post FREE

COMPUTER ADDICTS. At last, a purpose built trolley for the home computer and accessories. So convenient to keep your equipment safe, tidy and ready for use on a mobile unit. How have you managed without one. Solid wood frame

recessed upper & lower shelves. Prices from £18.25 + p&p 55p. Send now for further information to Setcraft, Sussex Ltd, 32 Walpole Ave, Worthing, Sussex BN12 4PL. SAE appreciated.

## CLUBS

Software Exchange. Swap your used software. Spectrum speciality. FREE membership. S.A.E. UK SEC, (HCW), 15 Tunwell Grave, Sheffield S5 9GB.

## REPAIRS

**ZX81 - Spectrum.** We can now offer out-of-guarantee repairs by our Computer Dept. Our engineers have had over three years experience servicing Sinclair Computer products. Price including p&p. ZX81 - £11.50; 16K Ram - £9.95; Spectrum - £18.75. Send with cheque or PO. T.V. Service of Cambridge, French's Road, Cambridge CB4 3NP. Phone (0223) 311371.

## MICRO COMPUTER REPAIRS - VERY FAST SERVICE

VIC-20 • Spectrums • C64 • Pets  
Tel: SLOUGH (0753) 48785  
(Mon - Sat)  
WE ALSO REPAIR ALL COMMODORE  
SYSTEMS

## SERVICES

### COMPUTER PRINTED self-adhesive CASSETTE LABELS

4p each - min. chg. £2-£3.50 per 100  
Black on white (text only). CW.O.  
PAMCOMMS LTD.  
21 Wycombe Lane, Woodburn Green,  
High Wycombe, Bucks. HP10 0HD

### ALL YOUR CASSETTE NEEDS

Blank cassettes C15 with case, 40p each.  
Labels in Blue, White or Yellow, 20 for 36p. Inlay cards in Blue, Red or Yellow 20 for 60p. Library cases, 9p each.  
Postage on each complete order 55p. Stonehorn Ltd, (HCW), 59 Mayfield Way, Barwell, Leicester LE9 8BL.

### ZX81 REPAIR SERVICE AT LAST NO NEED TO WAIT FOR WEEKS

Send your faulty ZX81 for fast reliable repair. We will repair any ZX81 KIT or READY BUILT UNIT Only £15.95 fully guaranteed + p+p £1.75  
Please state the nature of problem. Send cheque or postal order to NEXT COMPUTER SYSTEMS, 89 HARVEST RD, (H.C.W.) ENFIELD GREEN, SURREY TW20 0QR.

## SOFTWARE APPLICATIONS

### SPECTRUM KOPYKAT IMPROVED PERFORMANCE

Simply the best. Copying any program is now as easy as LOADING and SAVEing your own programs. Any ZX Spectrum program can be backed-up onto a fresh tape. Even programs that cannot be stopped can now be copied. 100 per cent machine code. Prints file names. Copies headerless files. SPECTRUM KOPYKAT uses no program area so full size programs over 41.7K (9K for 16K machines) can be copied. PLUS FREE Header Reader program.

Despatched by first class return of post.

Send cheque/PO for £4.95 to:

**MEDSOFT**  
61 Arden Road, Doncaster,  
South Yorks DN2 5ER.  
IT CAN EVEN COPY ITSELF

Spectrum tape copier. Copies all tapes. Full instructions. Easy to enter listing, £2.00. On tape, £3.50. G. Sim, 95 Harbourne Avenue, Paignton, Devon.

## TAPE COPIER

The most advanced BACK UP COPIER for ANY SPECTRUM available. MICRODRIVE COMPATIBLE. Does any other copier come near? LOOK at SOME of its options:  
• MAXBYTES copies programs occupying the FULL 16K or 48K! Verifies. Repeat copies. Auto. Abort. STOPS programs.  
• Loads CONTINUOUSLY (not just one part at a time like most copiers) even without pressing a key. Copies HEADERLESS and ALL programs that we are aware of! Very simple to use.  
• We offer a FULL MONEY BACK GUARANTEE if you are not fully satisfied. Cost only £4.49.

LERM (DHG),  
16 Stonepit Drive, Cottingham,  
Mkt. Harborough, Leics.

## FOR SALE

VIC-20 Starterpack. 5 months old, including Jellymonsters, 6 O-Level revision cassettes, Choplifter, Xenon-2 and 16K RAMpack. £190. Tel: 01-575 0292.

Sharp MZ 80K (40K). Perfect condition, including high resolution graphics and lots of programs. £300 o.n.o. Tel: 01-455 9566.

TRS 80 48K Model 1 with LC mod. RS-232 line printer 7, £700. 0264 772127 (evenings) 0264 82770 (day).

## HARDWARE

Home and Business micro computers bought and sold. Apple equipment always required. Your BBC stockist in Berkshire.  
Tel: 0344 84423

## FOR HIRE

To Hire a Computer from ZX81 upwards, ring or write to: Business and Computer Services, 292 Caledonian Rd., N1 1AB. Tel: 01-607 0157.

Oric Software Library. Two weeks hire £1. Annual Membership £5. Stamp for list. Les Wilson, Penallick, Tintagel, Cornwall.

## HCW YOUR SOFTWARE SUPERMARKET.

## SOFTWARE GAMES

### LANTERN SOFTWARE TI99/4A

Discover our range of arcade games and utilities. High quality software at New Low Prices.  
Daddie's Hot Rod £5.95 Troll King £5.95  
Runner on Treiton £5.95  
NEW !! Builder/Minefield - Two great games for youngsters - £4.95  
The Black Tower - from the author of Troll King - £5.95  
Hunchback Hawok - 24 sheets of action - unequalled in speed and graphics - simply the best - £5.95  
For a full list of these, our Ext-Basic range and more send S.A.E. to: 4 Haffenden Road, Tenterden Kent TN30 6DD.

### SPECTRUM PROGRAMS

Gnasher £4.95, Arcadian £4.95, Escape £4.95, Backgammon £5.95.

All 16K and many more. Crossed cheques/PO's to: VYAJYS HK or SAE. For full list to VYAJYS HK, 11 Margaret Avenue, St. Austell, Cornwall.

**Dromeda Software.** Quality games for TI-99/4A. S.A.E. for details. 56 Wells Street, Haslingden, Lancashire BL0 9AN.

**Computer games, discount prices.** Free catalogue. Send S.A.E. to: A. D. Software, 17 West Street, Wath on Dearne, Rotherham S63 7QU.

Transform your 48K into a W.W.2 fighter

### ORIC-1

"BATTLE FLIGHT"  
Flight & Combat Sim. in hi-res £4.95 inc. P&P

And fun for all the family with

"MEMORY GAME"  
£3.95 inc. P&P

Xmas Offer BOTH for £7.95

STOUR COMPUTING  
16 Old Bridge Road,  
Bournemouth BH6 5RG

Astasoft TI-99/4A software. Extended BASIC. Dreamer. You are trapped in a nightmare world of monsters, can you survive? 26 screens and keeps top scores on tape. Cheques please to: E. A. Stanley, 4 Victoria Court, Victoria Road, London E18 1LH. £5.50. Needs joysticks. Tape.

## PROBLEMS WITH YOUR MACHINE? SCAN OUR SERVICE/REPAIR SECTIONS.

### 4 FOR TEXAS!

TEXIGOLF Super golf game for the TI. Choose from 16 directions and 11 clubs. Lower your handicap! £3-50  
HANGMOG Save the nousey mog from the meat factory mincer with your knowledge of words! £3-20  
FLASH Save Earth Data Base from aliens! Zap robots as they land. Hunt Green Leader (Joysticks) £3-20  
BANGER Negotiate a stock-car track in your banger. Watch out for trees, wrecks etc! (Joysticks) £3-00  
14 STATION RD  
BROOKHURST  
N. HERTS. SG9 5DE.  
Payments to SofTI.

### VIC-20 Adventures

KRAAL'S KINGDOM (as reviewed in this issue and in Micro Adventurer Nov.) In 2 16K parts £4.95.

MAROOED  
16K very addictive £4.50.

DEATH HOUSE  
100% graphic adventure £4.95.

All games will soon be available for the Spectrum. Add 50p p&p

BUNTASOFT

149 Monks Walk, Buntingford,  
Herts SG9 9DS

## HCW — COMPATIBLE WITH ALL POPULAR HOME COMPUTERS.

### ATARI 400/800

"MADAME GUILLOTINE"  
Novel version of hangman. Can you win a front row seat in the Bastille?  
Only £5.95 inc. Cheque/PO's to:

T. Smith Software (Dept. HCW)  
26 Wesley Grove, Portsmouth,  
Hants, PO3 5ER

Mail Order Only SAE for lists

## THIS SPACE IS VACANT. REACH THE RIGHT AUDIENCE AT THE RIGHT PRICE BY PLACING YOUR VACANCY IN THIS SECTION. RING 01-437 1002 EXT 213.

### ORIC-1

"FIND THE FLEET"  
Four skill levels. Mines and optional sound. £3 inclusive.

TRADSOFT

23 Meyrick Close, Knaphill,  
Woking, Surrey

### TRON!

Tron light-cycles. Can you surround the opposing light-cycle before it ZAPPS you? High score display and sound incorporated. Excellent flicker-free action on cassette for Atari 400/800, with full instructions and money-back guarantee. £6.83 (inc. p&p + VAT) to:  
P. W. SOFTWARE INC.,  
25 Chart Place, Gillingham,  
Kent ME8 0LN

## SOFTWARE EDUCATIONAL

Learning to drive?

Driver who thinks he knows it all?

### LEARNER DRIVER 16K Spectrum (FREE Highway Code)

Two fascinating educational fun programs from a professional driving school on one tape.

PASS YOUR TEST

Driving Test Simulation. Are you good enough to pass first time? and

KNOW YOUR SIGNS

Test your knowledge of the Highway Code. Both 16K programs on tape.

Unique and excellent value at an inclusive price of £6.00. Cheques to:

M. J. Hawkins, D.O.T.A.D.I., M.I.A.M.  
Stowe IX Churches School of  
Motoring (Est. 1974) Benu Vista,  
Church Stowe, Northampton

## DO YOU OFFER A SERVICE PEOPLE IN COMPUTING REQUIRE? IF SO WHY NOT TELL THEM ABOUT IT? RING 01-437 1002

## USER GROUPS

TI99/4A. Yahtzee free. Details only when you join nationwide group. S.A.E. TI-users, 40 Barrhill, Brighton, BN1 8UF.

## WANTED

PERSONAL COMPUTERS  
All models bought for cash.

Morgan Camera Company  
160 Tottenham Court Road  
London W1. Tel: 01-388 2562

## XMAS GIFTS

### Micro-Users SOFTWARE T-SHIRTS AND SWEATSHIRTS

1 Apple	6 I'm User Friendly
2 Spectrum	7 Have you seen my
3 Oric 1	Peripherals?
4 Epsom	8 Z80A
5 Invader	9 6502

100% Cotton T-shirts in white, red or sky £3.25 each inclusive.

Poly-cotton Sweatshirts in white or grey £5.50 each inclusive, small, medium, large and extra large sizes.

Mail Order only from:  
One Per Cent Screens, Unit 12, Star Lane Estate, Great Wakering, Essex.

### MICRO CHIP POSTER

40 x 50cm poster featuring Motorola MC68000 16-bit microprocessor chip in die form showing fine circuit details at a magnification of 150 x.

SATELLITE POSTERS  
41 x 60cm Landat poster showing whole of U.K. 48 x 70cm. Meteosat poster showing whole of earth, only £1.75 each or £4.50 for any three. Add 5p p&p per order.

Send Cheque/PO to:

Climax Computer Systems Ltd,  
17A Broad St. South Molton,  
Devon EX36 3AR  
Tel: 07695 2314

## SPECIAL ANNOUNCEMENTS

### TI-99/4A

Stainless Software will continue to support the TI-99/4A and still welcomes new programs. Well written original programs are welcome and we will consider taking over ranges of programs. Please write with SAE for details. For software catalogue please send large SAE.

STAINLESS SOFTWARE  
10 Alstone Road, Stockport,  
Cheshire SK4 5AH

## PLEASE NOTE THAT WE ARE MOVING TO NEW OFFICE PREMISES ON MONDAY 19th DECEMBER. WRITE TO 1 GOLDEN SQUARE, LONDON W1 OR TELEPHONE 01-437 0699 TO BOOK YOUR ADVERTISEMENT SPACE.

## RECRUITING? SELLING A PRODUCT? OR A SERVICE? GET MAXIMUM BENEFIT FOR YOUR MONEY FIND OUT ABOUT OUR WHOLE RANGE OF PUBLICATIONS IN:

## COMPUTING ELECTRONICS VIDEO RADIO

Simply telephone

### ASP CLASSIFIED

01-437 1002

(We take Access and Barclaycard)

# CLASSIFIED ADVERTISEMENT — ORDER FORM

1.	2.	3.
4.	5.	6.
7.	8.	9.
10.	11.	12.
13.	14.	15.

## PREFERRED CLASSIFICATION

Please place my advert in Home Computing Weekly for \_\_\_\_\_ weeks.  
Please indicate number of insertions required.

Advertise nationally for only 35p per word (minimum charge 15 words).

Simply print your message in the coupon and send with your cheque or postal order made payable to Argus Specialist Publications Ltd to:

CLASSIFIED DEPT., HOME COMPUTING WEEKLY,  
145 Charing Cross Rd., London WC2H 0EE.  
Tel: 01-437 1002.

Name .....

Address .....

Tel. No. (Day) .....



--	--	--	--	--	--	--	--	--	--	--	--	--	--	--	--	--	--	--	--

## T199/4A SOFTWARE

**PILOT** £5.95

A great new flight simulation game for the unexpanded T199/4A. Graphics display of landing strip and terrain map, plus updated instrument panel. Options for take-off, landing or in flight. Full instructions included. Graphics in sound.

**TI TREK** £5.95

Defeat the Klingon invasion fleet. Features include 5 skill levels, graphics, quadrant display, galaxy map, phasors, photon torpedoes, long range scans, damage reports, shield control, impulse and warp drive. Eight by eight galaxy. Full instructions included. Graphics and sound.

Send cheque or P.O. or telephone with Access, Barclaycard for immediate despatch. Please add 50p p&p to orders under £7. Orders over £7 post free.

### APEX SOFTWARE

Swiss Cottage, Hastings Road,  
St. Leonards-on-Sea, TN38 8EA  
Tel: Hastings (0424) 53283



## Texas T199/4A



**ARENA III** (EXT. BASIC) £4.95

Space war. Defend your ship from attacking aliens. Battle your way to Arga. To land, you *must* blast out a landing strip. Descend from ship through treacherous meteor storms. Laser cannon, neutron bombs, space walks. This game has the lot.

**PINBALL + CUBITS** (EXT. BASIC) £4.95

Two games on one tape. A realistic pinball machine. All the excitements of the real thing. Cubits: A test of skill and memory for those who like a challenge.

**POSTMANS KNOCK** (BASIC) £4.95

"ON YOUR BIKE" says the Boss. Wobble through dense countryside. Post letters; empty postboxes; pick up parcels. Have you time to do it, before the post office does the sorting? Ride the regulation bike (with bell). It is not easy! Extra screen for High Scores, unless you are sacked first!

Send cheque or P.O. to Lizard Games, Orders post free.

14 Bridgwood, Brookside, TELFORD, Shropshire TF3 1LX.

# THE

# Ω MEGA RUN

## ... is coming

## SOLWAY SOFTWARE

FOR THE TEXAS T199/4A (UNEXPANDED)

### SYSTEM TRADER

Can you land safely on each planet AND make a profit? Instrument display for launching and landing text for trading. Uses full 16K. Side 2 is a typing text. £5.95

### CRUISER

Take a holiday on the "Texas" canals. But don't expect to relax! Graphics. Side 2 is a character generator. £4.95

Prices include P & P.

### Solway Software

6 CURZON STREET, MARYPORT  
Telephone: (0900) 812579

COMING SOON!

Tumbledown Tower. A "classic" adventure with a difference!  
Please send S.A.E. for details of these and others.

# CALPAC LEARNING SERIES

Colour graphics and sound are used extensively to make learning more enjoyable.

**5. MULTIPLICATION TABLES.** This program with correction sequences enables you to test individual multiplication tables, or all tables up to a maximum that you choose. Carriages are added to a train as the score increases - see the train glide through the countryside when the test is finished.

**6. THE ROMANS.** Answer questions on the Romans to win a horse, chariot, viaduct and temple. Answer enough correctly and the horse will gallop away with its chariot.

© J. J. Warren 1983  
Published by Calpac Computer Software, 108 Hermitage Woods Crescent, St Johns, Woking, Surrey GU21 1UF

**7. SPELLING TESTER.** The words in the test are initially displayed on the screen. Then short sentences are used as prompts for the words, which must be typed correctly to add stages to a space-ship.

Replace the words and sentences in the program with weekly spelling lists, save them on cassette, and you will rapidly create a whole library of programs.

**8. HOMOPHONES.** See or sail, bare or bear? Choose the correct word to complete the sentence. Extra motivation is provided by a coloured pot-plant, which grows with each correct response. The plant flowers in an unusually tuneful fashion at the end of the program.

The programs on this cassette are subject to copyright, and may not be copied, transmitted, hired or lent without the written permission of Calpac Computer Software.

CALPAC  
LEARNING SERIES  
ZX SPECTRUM  
VOL. 2

SEE US AT THE

9th  
ZX MICROFAIR

Saturday / Sunday  
December 3-4  
Alexandra Palace

# CALPAC LEARNING SERIES

PROGRAMS 5-8

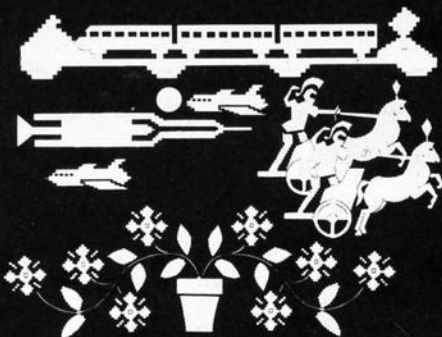

5. MULTIPLICATION TABLES  
6. THE ROMANS  
7. SPELLING TESTER  
8. HOMOPHONES

SPECTRUM 16K  
FROM 7 YEARS 48K

# CALPAC LEARNING SERIES

Colour graphics and sound are used extensively to make learning more enjoyable.

**9. HOURS, VERBS, ADJECTIVES AND ADVERBS.** Sentences are displayed and you select the named parts of speech. Instant feedback and helpful comments ensure positive learning. Correct answers are rewarded by the creation of a coastal scene, which is animated at the end of the program.

**10. VERB PRACTICE.** You have to complete the sentences using the correct tenses of the verbs. The program concentrates on those irregular verbs that often cause difficulty. An underwater landscape is created as questions are correctly answered.

© J. J. Warren 1983  
Published by Calpac Computer Software, 108 Hermitage Woods Crescent, St Johns, Woking, Surrey GU21 1UF

**11. THE STRUCTURE OF THE FLOWER.** This program explains how the parts of the flower are involved in the formation of seeds. This is a three part program which makes full use of high resolution colour graphics.

**12. LONG DIVISION.** This detailed program takes the learner through long division sums in easy stages. Correction sequences are automatically provided when they are needed. Sums with remainders can be chosen if required.

The programs on this cassette are subject to copyright, and may not be copied, transmitted, hired or lent without the written permission of Calpac Computer Software.

CALPAC  
LEARNING SERIES  
ZX SPECTRUM  
VOL. 3  
FROM  
9 YEARS

# CALPAC LEARNING SERIES

PROGRAMS 9-12

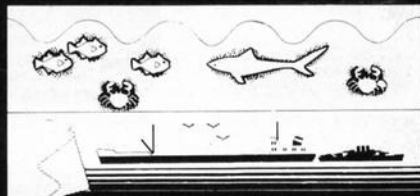

9. HOURS, VERBS, ADJECTIVES AND ADVERBS  
10. VERB PRACTICE  
11. THE STRUCTURE OF THE FLOWER  
12. LONG DIVISION

SPECTRUM 16K  
FROM 9 YEARS 48K

Our software is suitable for use in the home, school or college.

For further details or retail stockists please telephone:- 048 67 2584

We have a demonstration cassette available for retailers or schools.

We would like to hear from good programmers, graduates or teachers wishing to participate in the expansion of our Learning Series on the Spectrum, BBC Model B and other machines.

Our software is available by direct mail from:-

CALPAC COMPUTER SOFTWARE  
108 Hermitage Woods Crescent  
St Johns, WOKING, Surrey GU21 1UF

#### PRICE LIST

CALPAC LEARNING SERIES VOL 1	16K or 48K Spectrum	£9.50
CALPAC LEARNING SERIES VOL 2	16K or 48K Spectrum	£9.50
CALPAC LEARNING SERIES VOL 3	16K or 48K Spectrum	£9.50
CALPAC CHEMISTRY SERIES VOL 1	48K Spectrum	£7.50
CALPAC CHEMISTRY SERIES VOL 1	16K ZX81	£6.95
CALPAC PATTERNS	16K ZX81	£5.95

Additional features of the CALPAC LEARNING SERIES include:-

- \*Spelling checkers
- \*\*"Help" call up routine
- \*Easy insertion of subject material of your own choice into the programs

LIFT OFF with



# SPACE SHUTTLE



SPECTRUM LAUNCH STAGE



DRAGON 32 ARM STAGE



BBC FINAL STAGE

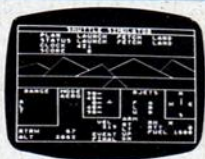

ATARI FINAL STAGE

## MISSION BRIEF

Successfully pilot the Shuttle through Launch, Fetch & Finals. Take off and position Shuttle in orbit  
Manoeuvre alongside malfunctioning Satellite. Retrieve - then re-enter to glide without fuel to White Sands Desert.

## PREVIOUS SUCCESSFUL MISSIONS

EXCELLENT - "Personal Computer News"  
A WELL THOUGHT OUT GAME - "Dragon User"  
ALMOST WORTH BUYING A DRAGON FOR -  
"Which Micro"



**MISSION STATUS** Available for  
48K ORIC 1, ATARI 16K, DRAGON 32, BBC  
MODEL B, SPECTRUM 48K, COMMODORE 64,  
ACORN ELECTRON, TANDY COLOUR 32K  
CASSETTE £8 DISK £10

Postal Orders to  
41 Truro Road, St. Austell, Cornwall PL25 5JE  
Telephone/Credit Card Order  
Tel: 0726 3456

Available from computer dealers  
nationwide or from larger branches of



# MICRODEAL



John Menzies