

AUST MAG
\$3.00

THE AMSTRAD USER

Issue No. 12 \$3.50

January 1986

FREE FOR
SUBSCRIBERS
See Page 17

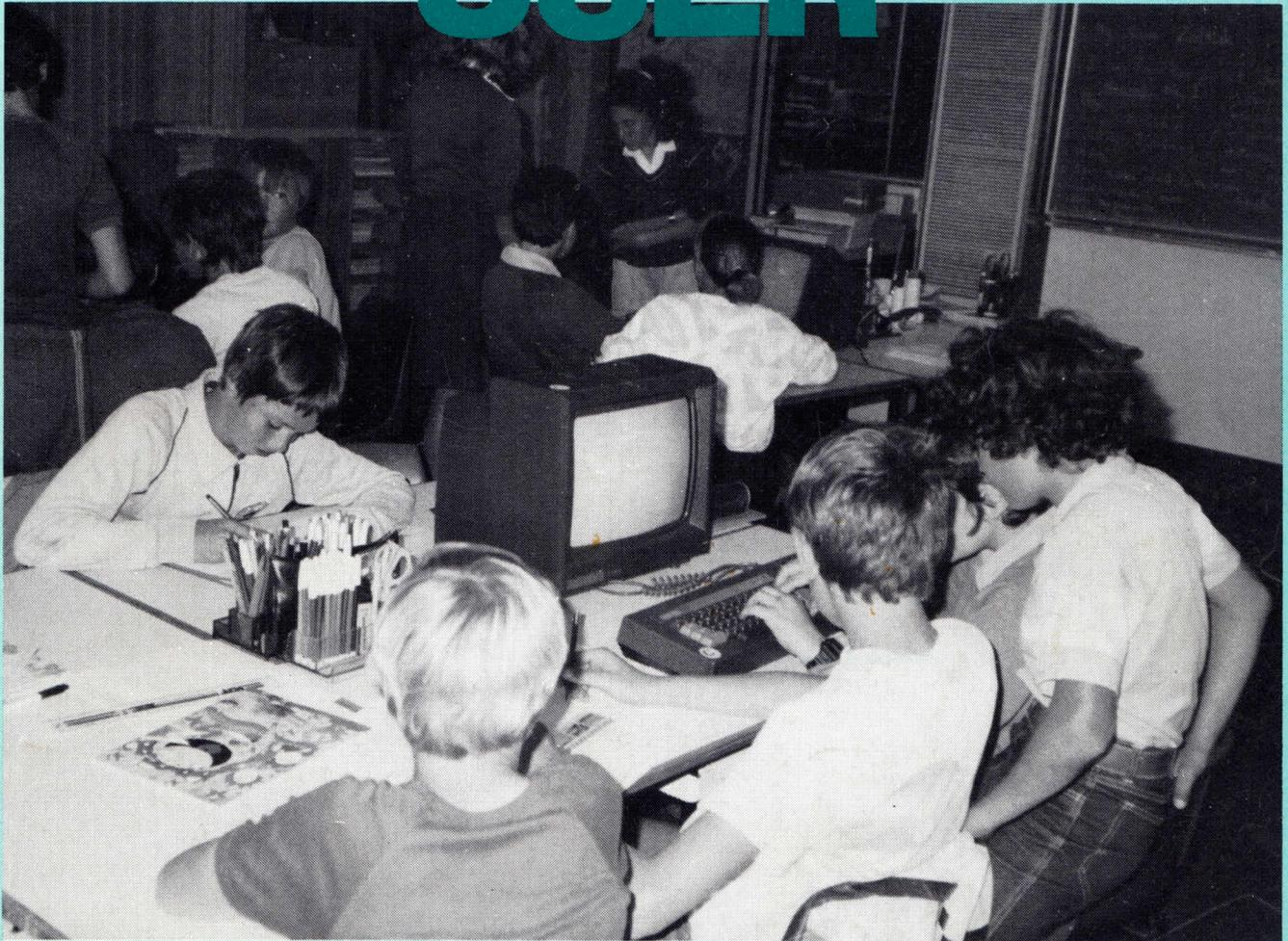

- *GUIDE TO A 5.25" DISC DRIVE POWER SUPPLY*
- *SPACE EXPLORER - AN EDUCATIONAL GAME*
- *COMPUTERS IN THE CLASSROOM*
- *USER GROUP INFORMATION*

FOR THE NOVICE & EXPERIENCED USER

Registered by Australia Post - Publication No VBP7017

THE LATEST VIDEO GAMES FROM AMSTRAD

DARE YOU TAKE THEM ON?

So you're pretty hot at video games are you? We dare you to take on these. They're the latest video game challenges from Amstrad and they're out to win.

The substantial RAM in the Amstrad CP464 has provided our software authors with greater scope to bring you more challenging, more cunning, more exciting fun than ever. If you dare!

Ask your nearest Amstrad dealer for full details on these and all Amstrad software for home or business.

When ordering please quote catalogue number.



Airwolf
SOFT 06011 (Joystick only)
Based on the series, only you are trained to fly the billion dollar helicopter Airwolf. Your mission — free five US scientists held hostage deep beneath the scorching Arizona desert. You'll need all Airwolf's stealth capabilities in a series of night time missions, and that mightn't be enough!

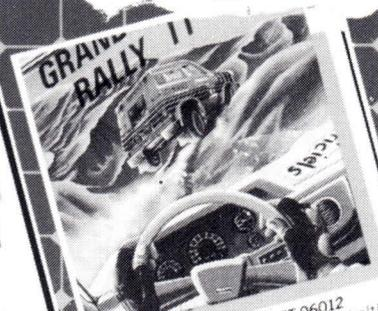

Grand Prix Rally II SOFT 06012
(Joystick only) Put on your seat belt! You're in a world famous rally at the wheel of a fabulous racing car. Darkness, ice, rain, desert, fog all test you. Don't crash into your competitors! The road is in 3-D and fast! Great graphics, and you can create your own tracks too!



Fantastic Voyage SOFT 984
(Keyboard or Joystick) Based on the movie. You have been miniaturised and are inside a human body. To escape you must reassemble your pieces. But can you overcome the viruses, cholesterol blocks, growths and infections? Will you escape in time?



The Way of the Exploding Fist SOFT 026 (Keyboard or Joystick)
Master this ancient martial art — progress from novice to Tenth Dan. 18 manoeuvres include blocks, flying kicks, leg sweeps, roundhouse, even somersaults! Challenge the computer or a friend. Dazzling animation and competitive action.

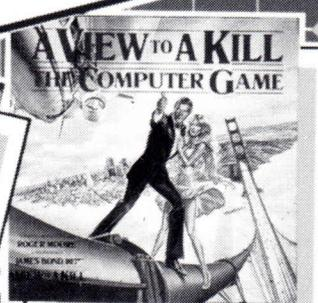

A View To A Kill SOFT 027
(Keyboard or Joystick) Based on the Movie. Dare you be James Bond? Three exciting adventures from the film, including a stunning 3-D taxi chase through Paris, a desperate escape from the burning City Hall and a descent down the mine shaft to remove a nuclear detonator.

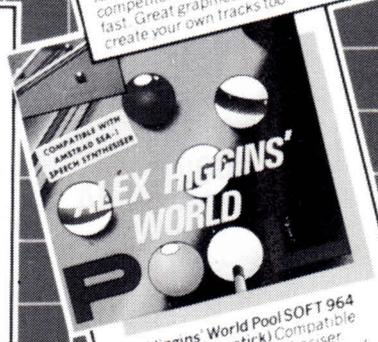

Alex Higgins' World Pool SOFT 964
(Keyboard or Joystick) Compatible with Amstrad SSA-1 synthesiser. Challenge your friends to a game of pool, and sink the spotted or striped balls. It's just like the real game. You can even spin the cue ball. Alex Higgins' World Pool is a great new angle on a classic game.



Braxx Bluff SOFT 955
(Keyboard or Joystick) You control an intergalactic rescue cruiser. Can you find and save a planetary exploration team stranded in their Rover vehicle? First you must land on the treacherous Braxx Bluff. Fight off the energy eating creatures and get the Rover back through the acid sea in time.



Alien SOFT 956
(Keyboard and Joystick) Based on the movie "Alien". Can you destroy the alien or drive it away from your spaceship "Nostromo" before it destroys you? And which of your crew members is the android? Outwit the alien, but don't overstress crew members or you'll be in trouble!

AMSTRAD

Distributed and guaranteed throughout Australia by

AWA-THORN

THE AMSTRAD USER

Issue No. 12 January 1986

CONTENTS

Editorial.....	2
The Learning Centre - Introduction to Music Part 4.....	3
Junior Jotters - including a Drawing program.....	5
User Group Information.....	10
PAINTOUT - a game.....	12
Discounted Books for Subscribers.....	14
Firebird goes cheap-cheap.....	15
Computers in the Classroom.....	16
A "Thank you" gift for Subscribers.....	17
The Amstrad User Binder details.....	18
Guide to a 5.25" Disc Drive Power Supply.....	19
Result of "Win an Amstrad Library" Competition.....	22
New Subscriptions for the English Amstrad Computer User.....	23
Space Explorer - an educational game.....	24
Random Number Generation.....	31

For Tape Subscribers, the programs/routines can be found at these approximate counter readings:

Side 1 - SPACELDR:3, SPACEXP:12, PAINTOUT:91

Side 2 - DRAW:3

All enquiries and contacts concerning this Publication should be made to The Amstrad User, Suite 1, 33 The Centreway, Blackburn Road, Mt. Waverley, Victoria 3149, Australia. [Telephone: (03) 232 7055].

The Amstrad User is published each month by Strategy Publications. Reprinting of articles in The Amstrad User is strictly forbidden without written permission. All rights reserved. Copyright 1986 by Strategy Publications.

The single copy price of \$3.50 is the recommended retail price only. The subscription rate (for Australia only) is \$35.00 for 12 issues of the magazine only, or \$75.00 for 12 issues of the magazine plus tape containing all programs

appearing in that issue. Postage is included in the above prices. Overseas prices available upon application.

Please note that whilst every effort is made to ensure the accuracy of all features and listings herein, we cannot accept any liability whatsoever for any mistakes or misprints.

Contributions are welcome from readers or other interested parties. In most circumstances the following payments will apply to published material: Letters-\$5.00, Cartoons-\$5.00 and a rate of \$10.00 per page for programs, articles etc.

Contributions will not be returned unless specifically requested coupled with suitable stamped and addressed padded bag (for tapes) or envelope.

THE AMSTRAD USER

G'day and a very Happy New Year.

This may be the first Amstrad User for 1986, but for many it is the last on their current subscription. I have had an extraordinary number of people writing to ask how they should go about renewing their subscription or remind me to remind them when it is due. No worries! When the time is near, you will be sent a renewal form, and as you will discover on Page 17 of this month's magazine, for all subscribers who renew their subscription which becomes due during 1986, they will receive a free copy of our own "High Energy Programs for the Amstrad". For those who miss out, we hope to have the book in the bookshops later on in the year.

So what is your New Year Resolution? Apart from all the usual ones which attempt to reduce ones excesses, how about resolving to send a contribution to The Amstrad User during 1986? Or even better, sending two or three! It may surprise you that some \$4000 has been paid to contributors over the last eleven issues.

As promised last month, you can find details of The Amstrad User Binder on Page 18. It is difficult to gauge the demand - and they are not cheap to produce - so we've plumped for 250 to start with and will have more made if required. I must admit they are very smart with the silver lettering on the white cover and they do keep the magazines neatly in one place.... there are now only 249 available!

Finally, an apology for not letting you know that these offices closed on 19th December 1985 for a well earned holiday, and will re-open on Monday 13th January 1986.

See you next month,

Ed

The Learning Centre

An Introduction to Music - Part Four

by Peter Campbell

Last month we looked at the first four numbers in the sound command: channel status, tone period, duration and volume. These produce a tone for a length of time at our chosen volume setting and enable us to direct it to one or more sound channels, to hold it until we are ready to use it and to clear the sound queues of all sound. This month I am going to look at ways we can reshape the tone if it doesn't produce the sound we want.

Although Amstrad computers use a versatile sound chip, there are some things which we cannot do with the in-built facilities of our machines. These include filtering the sound to remove unwanted harmonics and changing the shape of the waveform which, in this case, is not the pure sine wave that was illustrated earlier in this series of articles, but a 'square' wave. Such features are found on one or two computers and are among the reasons why it is best to write sound programs for your own computer, rather than trying to convert something written for the 'Admiral 64', or whatever.

What then can we do? There are four main ways to alter the sound. The first is to vary the hardware. For example, we can attach a stereo amplifier and a pair of better quality speakers. We can then use the features of the amplifier to manipulate the sound by, say, boosting the bass and cutting the treble. With the right equipment we could even filter out the unwanted harmonics. Such an approach could be expensive, but a pair of speakers with a small amplifier built in, such as those used with 'Walkperson' cassette players, cost as little as \$39 and produce quite a significant improvement in sound

quality. There are cheaper units, but make sure there is some form of amplifier included, as the unamplified sound output from the Amstrad is not strong enough to drive a pair of speakers.

Secondly, we can experiment with playing two or three tones in unison. Try this by adding the following lines to last month's 'Silent Night':

```
122 notenumber=notenumber-12:
    status=5
123 frequency=440*(2^(octave=
    ((notenumber-10)/12)))
125 period=ROUND
    (125000/frequency)
128 SOUND status,period,
    duration*tempo,volume-3
```

So long as we choose notes which blend (remember tetrachords?), the sound output will be reshaped by the added harmonics which result.

To do more than that we must extend our SOUND command with a fifth and sixth parameter. The fifth number simply designates which volume envelope is to be used in conjunction with the particular SOUND command and the sixth, which tone envelope. These two envelopes enable us to manipulate the volume and tone period within a given sound. Let's look at each of them in turn.

In common with the SOUND command, the volume envelope (ENV) has a number of parameters which make it appear much more complicated than it really is! In chapter 6 of the CPC 464 User Instructions it appears something like this:

```
ENV N,P1,Q1,R1,P2,Q2,R2,P3,Q3,
R3,P4,Q4,R4,P5,Q5,R5
```

Actually, only the first four parameters need explaining, the rest follow the same rules.

Before we look at these parameters, considering what they are intended to do will give us some understanding of the effect of different values. Typically a musical note rises sharply in volume ('attack'), fades a little ('decay'), continues for a time (or about) a given level ('sustain') then fades away completely ('release'). This is, of course, a convenient simplification which some writers simplify further by describing the shape as attack, sustain and decay.

In reality, acoustic envelopes are very complex and can vary not only with different instruments, but also with the pitch of the note, the playing style of the musician and indeed the environment in which the music is heard! Just how complex can be seen if you have access to a digital oscilloscope, but Amstrad's ENV command enables us to experiment until we can achieve an approximation.

The first parameter, N, is the envelope number. This can take any integer value from 1 to 15. That is, we can choose from 15 volume envelopes at any given time.

Then follow the three parameters that describe a segment of the envelope. In Figure 1, I have sketched a volume envelope which reaches peak volume (15) in 0.15 seconds, fades to volume level 12 over the next 0.15 seconds, holds that level for 0.25 seconds and then fades away over 0.32 seconds. If this were volume envelope number 1, it would be written thus:

```
ENV 1, 5,3,3, 3,-1,5, 1,0,25,
4,-3,8
```

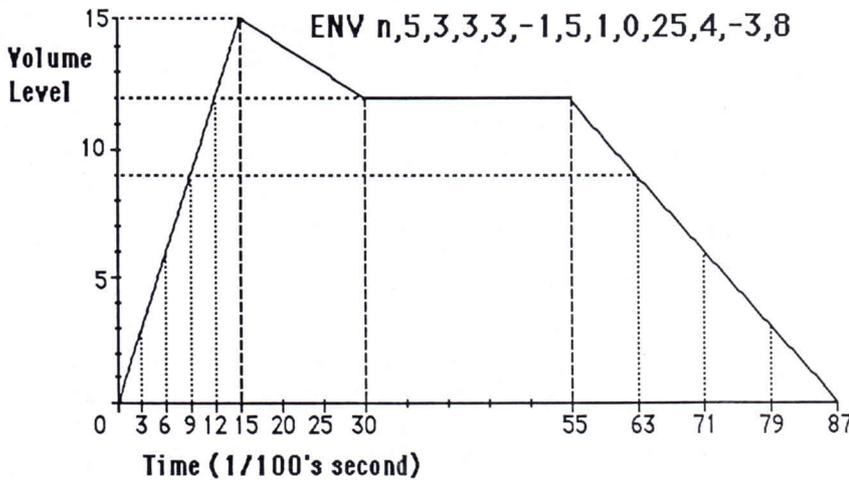

FIGURE 1

Notice that there are four segments each made up of a number of steps ('step count'), and variation in volume ('step size') and the time taken for each step ('step time'). The total time taken is $5*3 + 3*5 + 1*25 + 4*8 = 0.87$ seconds.

Add a SOUND command:

```
10 FOR i=1 to 5
20 ENV 1,5,3,3,3,-1,5,1,0,
  25,4,-3,8
30 SOUND 1,478,0,0,1
40 NEXT
```

and listen to the sound. (Note that making duration and volume zero, the ENV command takes control of the sound, which lasts precisely 0.87 seconds - the length of the envelope).

Now substitute this ENV command:

```
20 ENV 2,5,3,3,3,-1,5,1,0,
  33,8,-1,3
30 SOUND 1,478,0,0,2
```

The sound starts the same and lasts the same length, but it is sustained longer and fades out more quickly.

The User Instructions say that the value for the step count can range up to 127 and so it can, but if you take the volume above 15 or below 0 the results may not be what you expect! Try this envelope which takes the volume down a total of 32 units, starting from zero:

```
20 ENV 3,2,-3,20,10,-1,20,1,0,
  30,2,-3,20,10,-1,20
30 SOUND 1,239,0,0,1:SOUND 4,
  478,0,0,1:SOUND 2,119,0,0,1
(The three SOUND commands
just add some harmonics).
```

Five sections can be used in the envelope and this enables us to more closely match a curving envelope.

Tone envelopes are constructed in a very similar manner with one important difference. Tone envelopes (ENT) do not effect the duration of a note. Instead, they can be made to last as long as the note does by using a negative envelope number. (*Don't put the minus sign in the SOUND command, though!*) The effect of a tone envelope is to vary the tone period up or down, creating such effects as a vibrato.

Try adding this tone envelope to a sound command:

```
10 FOR i=1 to 5
20 ENT -1, 1,-1,12,1,1,12
30 SOUND 1,478,200,7,0,1
40 NEXT
```

Now turn line 20 into a remark and run the result. Notice the difference.

Tone envelopes can be used to create dramatic variations in tone:

```
10 ENT -1,5,5,1,10,-5,1,5,1,1
20 Sound 1,2000,2000,7,0,1
```

They can, of course, also be used with volume envelopes:

```
10 ENT -1,1,2,20
20 ENV 1,3,5,15,15,-1,255
30 SOUND 2,100,0,0,1,1
```

Well, that's it for this month. Next time I'll try to give you the rest of a music composer/synthesiser, as well as looking at ways of combining sound and action. In addition, there are some more musical notation and a few more terms that we can use. In the meantime, experiment with ENT and ENV and try to create approximations of some musical instruments. If you succeed, send in details of the ENT and/or ENV commands that create the effect so we can all experiment with them, perhaps refining them further.

NEW YEAR'S RESOLUTION

from Don Leith

Christmas time has come and gone
Along with Christmas Cheer
The time has come for promises
Resolutions for New Year

I promise and solemnly avow
Never to curse you this year
(Or at least not loud enough
so that you can hear)

I promise to use gentle strokes
And not pound a single key
(Which is really asking something
when programs won't run for me)

I promise to have you off
More than you are on
(Sorry Old Boy she's on my back
and I feel put-upon)

I promise to spend less on you
Than I ever did last year
(But considering how much I did spend
you have nothing to fear)

I promise to give her equal time
My God that's going to be tough
(I'll have to spend a lot of time with her
and you think you've got it rough!)

And finally there's one for me
She's made a promise you see
If I don't keep my word this year
Arnold, next year.... IT'S JUST YOU
AND ME!

JUNIOR JOTTERS

A Column for Young
Amstrad Users

LETTERS

I have enclosed a little program that I put at the end of my games on disc. The program asks you if you want to play other games on the same disc. It saves you from typing "RUN" or "LOAD" making them easier to get at. I started computing with a CPC464 when they first came out and now have a CPC664.

```
450 MODE 1
460 PRINT "WANT TO PLAY A DIFFERENT GAME?"
470 G$="INKEY$:IF G$="" THEN 470 ELSE
    G$=LOWER$(G4)
480 IF G$="Y" OR G$="y" THEN 560
490 CLS
500 PRINT "WELL - GOODBYE"
510 A=A+1
520 LOCATE 16,1:PRINT CHR$(250)
530 LOCATE 16,1:PRINT CHR$(251)
540 IF A=80 THEN 550 ELSE 510
550 CLS:NEW
560 MODE 1:CLS:CAT
570 PRINT"PLEASE TELL ME WHICH GAME YOU WISH TO
    PLAY NEXT"
580 INPUT Z$
590 RUN Z$
```

Tony Jeppesen, Bloomsbury, QLD

I am hoping that you can publish my small program in the Junior Jotters section of your magazine. It may be a small program but it can produce thousands of shapes. Instructions are included in the REM parts of the program. Here are some example - each set of numbers in a line is the shape:

Rectangles: 1,1:500,1:500,100:1,100
200,1:340,1:340,300:200,300
Squares: 1,1:100,1:100,100:1,100
1,1:200,1:200,200:1,200
Triangles: 1,1:600,1:300,250:1,1
1,1:600,1:600,398:1,1
Parallelograms: 1,1:400,1:600,300:200,300
630,1:600,200:1,200:30,1
Arrows: 50,1:300,400:550,1:300,100
1,200:600,400:300,200:600,1

For a different shape, use the same numbers of each shape except in a different order. For example:

Square: 1,1:100,100:100,1:1,100

If you increase lines 20, 30 and 40 to include I,J (and

change line 10) you can make more shapes such as a star or double triangles. Adding even more (K,L and M,N etc.) to the above lines makes it easy to draw simple pictures and designs.

Stars: 213,1:316,400:420,1:50,300:590,300
316,1:100,400:540,100:100,100:540,400
Dbl. Triangle: 1,1:100,100:200,1:300,100:400,1
1,100:100,1:200,100:300,1:400,100

This is the program:

```
1 CLS
2 ***PLOTING PROGRAM**
3 ***BY STEPEN RULE 1985 **
4 'JUST TYPE IN FOUR PLOT CO-ORDINATES.THE
  COMPUTER WILL AUTOMATICALLY DRAW THE SHAPE.
5 'BEARING IN MIND THAT THERE ARE ONLY 640
  HORIZONTAL PIXELS, AND 400 VERTICAL PIXELS IN
  ANY MODE, ANY NUMBERS ABOVE THIS WILL PRODUCE
  LINES THAT GO OFF THE SCREEN.
6 'TRY ALTERING THE NUMBERS TO GET DIFFERENT
  SHAPES.
7 MODE 1:INL 0,0;BORDER 0:INK 1,26
10 PRINT"ENTER 4 PLOT CO-ORDINATES"
20 INPUT A,B: INPUT C,D: INPUT E,F: INPUT G,H
30 PLOT A,B: PLOT C,D: PLOT E,F: PLOT G,H
40 DRAW A,B: DRAW C,D: DRAW E,F: DRAW G,H
50 END
```

Stephen Rule, Werribee, Vic.

SOFTWARE REVIEWS BY STEPHEN KERR

THE SCOUT STEPS OUT

The aim of the game is to boldly go where no other scout has gone before. On the way you can do good deeds such as cleaning the pensioner's flats, gathering mushrooms (not the red ones, they are poisonous), diving in the sea for samples of sea-life for the nature study class and even fixing the camp radio. You are also given the task of finding the stolen award-shields. Quite exhausting! As soon as this game is loaded you are shown a screen with scouts marking time. In the left hand corner there are about twenty cornflakes. When these are eaten, you are given a life. You are given the opportunity to have a tour which takes you round all the screens.

When you have completed a screen you get a bonus of two-thousand points. You can, of course, leave the screen before you have done this. On one screen there is a man who follows you around and if he catches you - you had better go back and get some cornflakes. Quite a good game but it takes quite a long time to load.

Ease of Use.....	5	Documentation..	4
Entertainment Value.....	8	Originality.....	6
Ability to Hold Interest..	8	Use of Graphics.	6
Speed.....	5	TAU INDEX...75%	

GRAPHIC MAGIC

This is not a game, instead it is a program which allows you to draw pictures and then save them on cassette. It uses one letter commands like A-ALPHABET, B-BOX, etc. These are all explained in the short manual. When you get started you will be shown a screen with a cursor in the middle and a line of colours at the bottom. You are able to change the colour at any time. When you press a button that is one of the commands it immediately responds. The pen is the cursor keys or the joystick. This game uses the twenty column mode, which allows more of the available ink colours.

Two very useful commands are A - ALPHABET and M - MODIFY INK. Alphabet allows you to print a letter wherever the cursor is. The main use of this is to write your signature in the corner. The only problem with this is when you write a letter the cursor doesn't move. So, if you don't move the cursor the next letter is on top of it. Modify ink can change an ink colour which can also change a colour in the picture if it is wrong.

To conclude this is a very good program and one which every one in my family liked.

JIGSAW MAGIC

This game goes with Graphic Magic. It uses the screens that you draw and mixes them up. If you do not have Graphic Magic a screen is provided on the tape. This is quite good and uses the colours well. When all this is loaded the computer mixes it up as you watch. You then have to move the pieces around the screen and you will be rewarded with a short tune.

You have three sizes and five levels to choose from. The bigger the size the easier; the lower the level the easier. This game is not an arcade game, it's more a puzzle and uses the joystick only, which is unfortunately not mentioned on the cover. It has given my family great fun trying to work out the puzzles except for Mum who couldn't work it out. I would recommend this to any one who likes jigsaw puzzles.

A DRAWING PROGRAM FOR THE CPC 664

From Gary Meinhardt

I am sixteen years of age and had fun with this simple drawing program for the CPC 664 on which you can draw pictures or create designs - eg. for T-Shirts etc.

Lines can be drawn by either using the four cursor control keys or the joystick for the four-way drawing actions (up, down, right or left), and the other directions (in between) can be achieved by using the 7, 9, 1 or 3 on the numeric keypad.

To get rid of unwanted lines, press <COPY> or the fire button and then draw right over the line.

The loaded program will display an introduction and then

the actual program. A small white dot will appear at the centre of the screen and this is where your drawing line will always return - the home position - when coming back from the main menu. There are guide notches on the bottom at intervals of approximately 30 pixels. This will come in handy when drawing circles and filling.

Press the <ESC> key twice and a menu will be displayed, and if the <SPACE> bar is pressed, one of three different menus will be displayed.

When the appropriate menu is displayed, you can select one of the following commands:

S- after you have drawn your work, press the <S> key and you can save it under a name (not more than 8 letters long).

L- you can get your work back by pressing the <L> key and following the instructions.

C- press the <C> key and 'DRAW' will clear the graphic screen and the cursor return to the 'home' position.

S- this will swap the pen, paper and border colours to your choice to give maximum resolution.

F- to fill you must give the position of the graphics cursor to be put inside the shape by using the scale at the bottom of the screen and by typing two numbers separated by a comma. The program will then ask what colour you would like.

0 - paper colour

1 - white

2 - pen colour

3 - flashing colour

R- returns you to the drawing mode and puts the graphic cursor in the 'home' position.

D- you can draw a circle anywhere and any size. Just follow the instructions and use the scale to help.

A- if you would like to give your drawing a title or name, follow the instructions on the screen.

C- this will enable you to change the speed of drawing, but I do not recommend to draw over 5 because it is too fast.

Conversion to the CPC 464

The FILL cannot be carried out on the 464 and has to be removed (lines 1990 to 2180). In addition, it is recommended that the program be run by disc drive owners only. You may have to change line 1530, which states:

```
1530 SAVE n$,b,49152,16384
```

where 49152 is the starting address of the screen memory and 16384 is the size. I have not tried it on the 464 as yet, so a few minor bugs could occur.

Note: This program was tested on a CPC 464 with a disc drive and, apart from FILL, worked well. However, when we saved it as an ASCII file it produced a Syntax Error message at the end of the save and did not save the file! We were successful in saving it as an ASCII file on a 6128. As yet, we haven't had a chance to work out why it won't save in this fashion on the 464. Has anyone any ideas? - Ed.

```

10 '
20 ' DEFINE CHR'S
30 '
40 SYMBOL AFTER 47
50 SYMBOL 48, &0, &18, &24, &24, &24,
&24, &18, &0
60 SYMBOL 49, &0, &8, &18, &8, &8, &8,
&1C, &0
70 SYMBOL 50, &0, &8, &14, &4, &8, &10
, &1C, &0
80 SYMBOL 51, &0, &1C, &4, &1C, &4, &4
, &1C, &0
90 SYMBOL 52, &0, &8, &18, &28, &3C, &
8, &8, &0
100 SYMBOL 53, &0, &1C, &10, &1C, &4, &
4, &1C, &0
110 SYMBOL 54, &0, &1C, &10, &1C, &14,
&14, &1C, &0
120 SYMBOL 55, &0, &1C, &14, &4, &4, &4
, &4, &0
130 SYMBOL 56, &0, &1C, &14, &1C, &14,
&14, &1C, &0
140 SYMBOL 57, &0, &1C, &14, &1C, &4, &
4, &1C, &0
150 SYMBOL 140, &0, &0, &0, &0, &FF, &9
9, &99, &FF
160 SYMBOL 142, &F, &9, &9, &F, &FF, &9
9, &99, &FF
170 '
180 ' INTRO
190 '
200 MODE 1
210 INK 0, 0: INK 1, 26: INK 2, 11: INK.
3, 6
220 PEN 1: BORDER 0
230 LOCATE 11, 12: PRINT"- A DRAWIN
G PROGRAM -"
240 PEN 3
250 PRINT" "; STRING$(1
7, CHR$(208))
260 PLOT 180, 260
270 FOR a=1 TO 43
280 READ x, y
290 DRAW x, y, 2
300 DATA 205, 260 , 205, 290 , 209,
290 , 209, 260 , 235, 260 , 235
, 290 , 209, 290 , 235, 290 , 23
5, 310 , 239, 310 , 239, 260 , 2
49, 260
310 DATA 259, 260 , 259, 290 , 262,
290 , 262, 280 , 290, 290 , 26
2, 280 , 262, 260 , 310, 260 , 3
10, 290 , 340, 290 , 340, 297
320 DATA 344, 297 , 344, 260 , 313,
260 , 313, 290 , 340, 290 , 340
, 260 , 355, 260 , 372, 290 , 37
8, 290 , 378, 260 , 383, 260
330 DATA 383, 290 , 383, 260 , 405,
290 , 408, 290 , 433, 260 , 433
, 290 , 436, 290 , 436, 260 , 46
0, 260
340 NEXT
350 LOCATE 11, 24: PRINT"Press SPAC
E to start."
360 IF INKEY(47)<>0 THEN 360
370 '
380 ' DRAW
390 '
400 CLS
410 INK 3, 26, 0
420 PEN 1
430 PRINT" - DRAW -"
440 PEN 2
450 PRINT STRING$(25, CHR$(131))+C
HR$(139)
460 FOR b=3 TO 25
470 LOCATE 26, b
480 PRINT CHR$(138)
490 NEXT
500 FOR a=1 TO 26 STEP 2
510 LOCATE a, 25
520 PRINT CHR$(140)+CHR$(142)
530 NEXT
540 LOCATE 27, 20: PRINT"<SPACE>-"
550 LOCATE 27, 21: PRINT"for next M
ENU,"
560 LOCATE 28, 24: PRINT"Select:"
570 LOCATE 1, 24: PRINT"30"
580 LOCATE 23, 24: PRINT"360"
590 PEN 1
600 LOCATE 32, 15: PRINT"7"CHR$(240
)"9"
610 LOCATE 32, 16: PRINT CHR$(242);
" "; CHR$(243)
620 LOCATE 32, 17: PRINT"1"CHR$(241
)"3"
630 LOCATE 29, 3: PRINT"MAIN MENU"
640 WINDOW #1, 27, 40, 5, 14
650 PAPER #1, 0
660 PEN 3
670 LOCATE 34, 24: PRINT STRING$(3,
CHR$(246))
680 '
690 ' DRAWING LINES
700 '
710 v=1
720 ON BREAK GOSUB 930
730 PEN 1: LOCATE 33, 16
740 ORIGIN 210, 200, 400, 0, 375, 17
750 e=1
760 DRAW ac, up, 1
770 IF JOY(0)=1 OR INKEY(0)=0 THE
N up=up+v: GOTO 870
780 IF INKEY(3)=0 THEN ac=ac+v: up
=up+v: GOTO 870
790 IF INKEY(10)=0 THEN ac=ac-v: u

```

```

p=up+v:GOTO 870
800 IF INKEY(13)=0 THEN ac=ac-v:u
p=up-v:GOTO 870
810 IF INKEY(5)=0 THEN ac=ac+v:up
=up-v:GOTO 870
820 IF JOY(0)=2 OR INKEY(2)=0 THE
N up=up-v:GOTO 870
830 IF JOY(0)=4 OR INKEY(8)=0 THE
N ac=ac-v:GOTO 870
840 IF JOY(0)=8 OR INKEY(1)=0 THE
N ac=ac+v:GOTO 870
850 IF JOY(0)=16 OR INKEY(9)=0 TH
EN e=e+1:FOR n=1 TO 300:NEXT:
GOTO 870
860 GOTO 770
870 IF e=2 THEN 890
880 DRAW ac,up,1:e=1:GOTO 770
890 DRAW ac,up,0:GOTO 770
900 '
910 ' MENU #1
920 '
930 CLEAR
940 ORIGIN 1,17,400,0,375,17
950 CLS #1
960 PEN #1,1
970 PRINT #1
980 PRINT #1," S ave your"
990 PRINT #1," work,"
1000 PRINT #1
1010 PRINT #1," C lear paper,"
1020 PRINT #1," L oad your"
1030 PRINT #1," work,"
1040 PEN #1,2
1050 GOSUB 2740
1060 a$=INKEY$:IF a$= "" THEN 1060
1070 ON INSTR("SLC ",UPPER$(a$)) G
OTO 1470,1590,1710,1120
1080 GOTO 1060
1090 '
1100 ' MENU #2
1110 '
1120 CLS #1
1130 PEN #1,1:PRINT #1
1140 PRINT #1," S wap"
1150 PRINT #1," colours,"
1160 PRINT #1
1170 PRINT #1," F ill,"
1180 PRINT #1
1190 PRINT #1," R eturn"
1200 PRINT #1," to work,"
1210 PEN #1,2
1220 GOSUB 2740
1230 a$=INKEY$:IF a$= "" THEN 1230
1240 ON INSTR("SRF ",UPPER$(a$)) G
OTO 1780,1950,2010,1290
1250 GOTO 1230
1260 '
1270 ' MENU #3

```

```

1280 '
1290 CLS #1
1300 PEN #1,1:PRINT #1
1310 PRINT #1," D raw a"
1320 PRINT #1," circle,"
1330 PRINT #1
1340 PRINT #1," A dd text,"
1350 PRINT #1
1360 PRINT #1," C hange"
1370 PRINT #1," speed of"
1380 PRINT #1," draw line,"
1390 PEN #1,2
1400 GOSUB 2740
1410 a$=INKEY$:IF a$= "" THEN 1410
1420 ON INSTR("DAC ",UPPER$(a$)) G
OTO 2220,2470,2600,950
1430 GOTO 1410
1440 '
1450 ' SAVE YOUR WORK
1460 '
1470 CLS #1:PEN #1,2
1480 PRINT #1,"The NAME of"
1490 PRINT #1,"the screen youwish
to save?"
1500 PEN #1,1
1510 INPUT #1,"";",n$
1520 GOSUB 2820
1530 SAVE n$,b,49152,16384
1540 GOSUB 2720
1550 GOTO 930
1560 '
1570 ' LOAD YOUR WORK
1580 '
1590 CLS #1:PEN #1,2
1600 PRINT #1,"The NAME of"
1610 PRINT #1,"the screen youwish
to load?"
1620 PEN #1,1
1630 INPUT #1,"";",n$
1640 GOSUB 2820
1650 LOAD n$
1660 GOSUB 2720
1670 GOTO 930
1680 '
1690 ' CLEAR PAPER
1700 '
1710 CLG
1720 GOSUB 2720
1730 CLS #1
1740 GOTO 710
1750 '
1760 ' SWAP COLOURS
1770 '
1780 CLS #1
1790 PEN #1,1
1800 PRINT #1," (0-26)"
1810 PEN #1,2
1820 INPUT #1,"Pen";d

```

```

1830 INPUT #1,"Paper";p
1840 INPUT #1,"Border";b
1850 BORDER b
1860 INK 0,p
1870 INK 1,26
1880 INK 2,d
1890 INK 3,26,p
1900 GOSUB 2720
1910 GOTO 930
1920 '
1930 ' RETURN TO DRAW
1940 '
1950 GOSUB 2720
1960 CLS #1
1970 GOTO 710
1980 '
1990 ' FILL
2000 '
2010 CLS #1
2020 PEN #1,1
2030 PRINT #1,"Coordinates"
2040 PRINT #1,"of fill:"
2050 PEN #1,2
2060 PRINT #1,"(seperated"
2070 PRINT #1," by comma)"
2080 PEN #1,1
2090 INPUT #1,":",a,u
2100 PRINT #1
2110 PRINT #1,"Colour of"
2120 PRINT #1,"Fill:"
2130 PEN #1,2
2140 PRINT #1," (0,1,2or3)"
2150 INPUT #1,":",c
2160 MOVE a,u:FILL c
2170 GOSUB 2720
2180 GOTO 930
2190 '
2200 ' DRAW CIRCLE
2210 '
2220 CLS #1
2230 PEN #1,1
2240 PRINT #1,"Coordinates"
2250 PRINT #1,"for centre?"
2260 PEN #1,2
2270 PRINT #1,"(seperated"
2280 PRINT #1," by comma)"
2290 INPUT #1,":",e,n
2300 PRINT #1
2310 PEN #1,1
2320 PRINT #1,"Circle size"
2330 PEN #1,2
2340 INPUT #1,s
2350 ORIGIN e,n
2360 DEG
2370 MOVE 0,s
2380 FOR a=0 TO 360 STEP 5
2390 DRAW s*SIN(a),s*COS(a)
2400 NEXT

2410 ORIGIN 0,30
2420 GOSUB 2720
2430 GOTO 930
2440 '
2450 ' ADD TEXT
2460 '
2470 CLS #1:PEN #1,1:PEN 1
2480 PRINT #1,"Type text any"
2490 PRINT #1,"-where in the"
2500 PRINT #1,"the boundry &"
2510 PRINT #1,"when finished press
      ENTER."
2520 LOCATE 1,3
2530 LINE INPUT"",a$
2540 PEN #1,2
2550 GOSUB 2720
2560 GOTO 930
2570 '
2580 ' CHANGE SPEED OF DRAW LINE
2590 '
2600 CLS #1
2610 PRINT #1," (0.5-5)"
2620 PEN #1,1
2630 PRINT #1,"What speed do"
2640 INPUT #1,"you want";v
2650 PEN #1,2
2660 GOSUB 2720
2670 CLS #1
2680 GOTO 720
2690 '
2700 ' GOSUBS
2710 '
2720 CLS #1:PRINT #1,"O.K.....":FO
      R t=1 TO 1000:NEXT
2730 RETURN
2740 s$="(:;t$=)"
2750 LOCATE #1,1,2:PRINT #1,s$
2760 LOCATE #1,1,5:PRINT #1,s$
2770 LOCATE #1,1,7:PRINT #1,s$
2780 LOCATE #1,3,2:PRINT #1,t$
2790 LOCATE #1,3,5:PRINT #1,t$
2800 LOCATE #1,3,7:PRINT #1,t$
2810 RETURN
2820 PRINT #1
2830 PRINT #1,"Is a Disc in"
2840 PRINT #1,"Drive A?"
2850 PEN #1,2
2860 PRINT #1,"(Y/N). "
2870 IF INKEY(43)=0 THEN 2900
2880 IF INKEY(46)=0 THEN 930
2890 GOTO 2870
2900 RETURN

```

User Group Contact List

Please note that the following names are listed as contact points for new user groups and should NOT be viewed as a problem solving service.

See other list for established groups.

NSW

Chris Craven	Canowindra	(063) 44 1150
Trevor Farrell	Coolah/Mudgee area	(063) 77 1374
T.J. Webb	Glossodia	(045) 76 5291
David Higgins	Inverell	(067) 22 1867
John Patterson	Lismore	(066) 21 3345
Paul Wilson	Moruya	(044) 74 3160
Frank Humphreys	Mummulgum	(066) 64 7290
Martin Clift	Narrabri	(067) 92 3077
Bob Hall	Newcastle	(049) 52 6915
Reuben Carlsen	North Sydney	(02) 957 2505
Stephen Gribben	Singleton	(065) 72 2732
Ken Needs	St. Ives	(02) 449 5416
Chas Fletcher	Toongabbie	(02) 631 5037
Nick Bruin Snr.	Tweed Valley	(066) 79 3280
Jim Owen	Uranga	(066) 55 6190
John Harwood	Windale	(049) 48 5337

Vic

Stuart McLean	4/304 Albert St. Sebastopol, 3356	
David Carbone	Burwood	(03) 29 4135
Rod Anderson	Camperdown	(055) 93 2262
Paul Walker	Heathmont	(03) 729 8657
Terry Dovey	Horsham	(053) 82 3353
Andrew Portbury	Leongatha	(056) 62 3694
Ron Butterfield	Leopold	(052) 50 2251
Sue Kelly	Manangatang	(050) 35 1402
Keith McFadden	Numurkah	(058) 62 2069
Mrs. G. Chapman	South Clayton	(03) 551 4897
Lindsay Parker	Wandin North	(059) 64 4837

QLD

Debbie Topp	Bribie Island	(075) 48 1688
Steven Doyle	Caloundra	(071) 91 3147
Mick O'Regan	Gladstone	(079) 79 2548
Kylie Telford	Goondiwindi	Calingunee246 (weekendsonly)
D.F. Read	Ingham	(077) 77 8576
Tim Takken	Ipswich	(07) 202 4039
Michael Toussaint	Loganlea	(07) 200 5414
Alan Laird	Maryborough	(071) 22 1982
R.C. Watterton	Toowoomba	(076) 35 4305

SA

Lindsay Allen	Murray Bridge	(085) 32 2340
---------------	---------------	---------------

WA

Dave Andersen	6 Kitchener Rd Merredin, 6415	
Graeme Worth	Scarborough	(09) 341 5211
P.M. Nuyens	Waroona	(095) 33 1179

TAS

Conal McClure	Scottsdale	(003) 52 2514
---------------	------------	---------------

NT

G.P. Heron	Tiwi	(089) 27 8814
------------	------	---------------

NATIONWIDE USER GROUPS

WESTERN AUSTRALIA

AMSWEST, Perth

President:	Tony Clitheroe	(09 275 1257)
Secretary:	Mrs. P.T. Ardron	(09 361 8975)
Treasurer:	Eric Stallard	(09 339 6361)

Regular meetings take place at a venue in Shenton Park on the first and third Tuesdays of each month starting at 7.30 p.m.

SOUTHSIDE AMSTRAD USER CLUB

President:	John Marshall	(09 390 7335)
Secretary:	Linda Marshall	(09 390 7335)
Treasurer:	Eric Tytherleigh	(09 390 8865)
Librarian:	Roy Depurouzel	(09 457 9026)

SAUC meets from 7.00 p.m. every 2nd and 4th Tuesday of each month at Thornlie Technical College. All meetings are socially orientated with a minimum of business matters and can include software and hardware demonstrations. Discounts have been obtained from most local dealers and are available to financial members.

ROCKINGHAM/KWINANA USER GROUP

Contact Bob Harwood on 095 27 1777 for further details on meeting times.

SOUTH AUSTRALIA

AMSTRAD COMPUTER CLUB INC. (SA)

President:	Chris Sowden	(08 295 5923)
Vice Pres:	Frank Matzka	(08 382 2101)
Treasurer:	Les Jamieson	(08 356 9612)

The group now meets each Tuesday at the Unley High School between 6.30 p.m. and 9.00 p.m. Any of the above officers can be contacted for further details and correspondence can be addressed to PO Box 210, Parkholme, 5043.

PORT PIRIE AMSTRAD USER GROUP

President:	Rick Cable	(086 32 5967)
Treasurer:	Dave Green	(086 32 6834)

The group meets at 7.30 p.m. on the first Monday of each month at the Princess Park Scout Hall, Three Chain Road, Solomontown. Meetings are well attended with members from Pt. Broughton, Warnertown and even Burra. For further details contact Rick Cable who will advise on the benefits of belonging to this group.

API COMPUTER GROUP

Contact:	Mike Denieuwe	(08 225 5995)
----------	---------------	---------------

The Australian Post-Tel Institute has a number of computer groups, almost entirely dedicated to Amstrads. Monthly meetings are held in:

Blair Athol	- 2nd Tuesday of the month at 5.30 p.m.
Elizabeth	- last Tuesday of the month at 5.30 p.m.
St. Marys	- 3rd Tuesday of the month at 5.15 p.m.
Christie Downs	- last Tuesday of the month at 5.30 p.m.

with a central meeting place in the City at various times

during the month. Membership is \$15 per year. For more details, contact Mike Denieuwe during office hours on the above telephone number, or on 08-297 8500 after hours.

VICTORIA

WESTERN AMSTRAD USER GROUP

President: Mike McQueen (03 312 5594)
Secretary: Peter Pilbeam (03 336 0705)
Treasurer: Frank Melino (03 337 2495)

The meetings are held on each alternate Tuesday and Sunday (to allow for shift workers) at the Tottenham North Primary School, South Road, Braybrook.

CENTRAL AMSTRAD USER SOCIETY

President: Rimon Russo (03 428 4281)
Vice-Pres: Dennis Whelan (03 367 6614)
Treasurer: Fred Gillan (03 598 5780)
PR Officer: John Holmes (03 434 1607)

Meetings are held twice a month in the Hall at the corner of Church and Somerset Streets, Richmond on the first Sunday of each month commencing at 4.00 p.m. and generally twelve days later on a Friday evening starting at 7.00 p.m. All meetings are conducted in a friendly atmosphere - families are welcome.

EASTERN AMSTRAD USER GROUP

President: Tony Blakemore (03 878 6212)
Secretary: Andrew Martin (03 729 8471)
Treasurer: Ron Dunn (03 277 7868)

Regular meetings are held on the first Sunday of every month at the Lutheran Hall, Station Street, Box Hill, (north of the Box Hill Post Office). The group organises tutorials for beginners as well as lectures and demonstrations. Proceedings commence at 2.00 p.m.

SOUTHERN AMSTRAD USER GROUP

President: Mike Prezons (03 781 2158)
Secretary: Martin Scragg (059 78 6949)
Treasurer: Steve Issell (03 786 9340)

Meetings are held on the third Tuesday of every month (except December) from 7.30 p.m. to 10.30 p.m. The venue is the Senoir Campus at John Paul College, Frankston.

NORTHERN AMSTRAD USER GROUP

Contact: Brian Ellis (03 469 4425)

This group caters for users in the Preston/Coburg areas. Meetings are devoted to learning more about computers and consist of lectures, demonstrations and practical workshops of projects such as modems, expansion busses etc. Arcade games are banned from meetings. The Group is privately funded and there are no membership fees.

SALE AMSTRAD GROUP

Organiser: Alan Harris (051 44 1454)

The Group meets informally every Thursday night from 7.00p.m. at the Sale Neighbourhood House in Leslie Street. In addition, small group tutorials are held twice a month. Contact Alan Harris for further details.

ACT

ACT AMSTRAD USER GROUP

Convenor: Arthur McGuffin (062 31 9437)
Secretary: Kevin Loughrey (062 31 2991)
Treasurer: Kevin Cryer (062 91 9881)

The group meets at 7.30 p.m. on the first Wednesday of each month in the Seminar Room of the Oliphant Building at the Research School of Physical Science, Australian National University.

NEW SOUTH WALES

JUBOL AMSTRAD USER GROUP of COFFS HARBOUR and DISTRICT

Contacts: Bruce Jones (066 52 8334)
Jim Owen (066 55 6190)

The "JUBOL" User Group is currently a small group covering the Coffs Harbour area. They have already met a few times in an informal manner and are very keen for other users in the area to contact them.

SYDNEY AMSTRAD COMPUTER CLUB

President: Raja Vijayenthiran (02 519 4106)
Secretary: Reed Walters (02 560 9487)
Treasurer: Jim Chrissy (02 327 7872)
Junior Rep: Daniel Story

This club, which services the inner City area, meets on the first Monday of every month at 7.00 p.m. A permanent meeting place has not yet been established so prospective members or visitors are advised to contact one of the officers listed above.

QUEENSLAND

BRISBANE AMSTRAD COMPUTER CLUB

President: Paul Witsen (07 371 9259)
Secretary: Mal Harper (07 288 3578)
Treasurer: Ian Cartwright (07 369 9364)

Meetings are held on the first Tuesday of each month at Junction Park State School, Annerley starting at 7.30 p.m. in Room 15a.

SOUTHSIDE AMSTRAD USER GROUP (QLD)

President: Michael Toussaint (07 200 5414)
Secretary: Sylvia Wilson (07 209 1947)
Treasurer: Col Liebke (07 200 5555)

Meetings take place every third Saturday of the month at 10 Carramar Street, Loganlea starting at 2.00 p.m. The group was formed to service the southern outskirts of Brisbane and membership consists of beginners to advanced programmers. Various demonstrations are given at meetings plus Basic programming instruction on a fortnightly basis and will later expand to include machine code.

TASMANIA

SOUTH TASMANIA AMSTRAD USER CLUB

An inaugural meeting was held recently at which nearly 30 people attended. Future meetings will take place at the Elizabeth Matriculation College (off Elizabeth Street) on the first Wednesday of each month, commencing at 7.30 p.m. Enquiries should be made to Graham West - (002) 34 5817.

Paintout

A Game from Andre Urankar

PAINTOUT is a strategy game based on the Gaussian Theorem of Convergence of Probabilities, which suggests that this puzzle can be solved but could take up to 625 moves (ie. 25 x 25).

However, depending upon the starting condition (which is randomly set up by Ami), an almost complete solution can be obtained within about 20 moves.

The presentation of the puzzle is described within the program itself. Inputs are all single characters and therefore do not require the use of the <Enter> key.

If it becomes hopeless, then press the <?> character to end the current arrangement.

The routines and subroutines within the program are:

```
10 Author details
Subroutine Area
70 Set up Pattern
130 Draw pattern on screen using 'redefining of
    windows' concept.
210 Draw field outlines
250 Label the screen blocks
290 Draw the changed blocks
390 Main program loop
590 "Win" response
690 "Give-up" response
770 Initialisation and Instructions
```

Variable names have been chosen to indicate the functions so that modifications can be easily achieved (if required).

As a suggested enhancement, a sound routine could be added at line 325.

If you manage to solve the puzzle within a 'low' number of moves, then perhaps you should apply to the MENSA Society (or are you a member already?)

```
10 'Program Name: PAINTOUT
20 'Developed By: A.M. Urankar
30 'Date: October 1985
40 '
50 GOTO 770
60 '
70 '*** Subroutines
80 RANDOMIZE TIME
```

```
90 FOR square=1 TO 25
100 IF RND(1)<0.5 THEN area(square)=0 ELSE area(square)=1
110 NEXT: RETURN
120 '
130 n=1
140 FOR y.fill=0 TO 4: sy=offset.y
    +y.fill*4
150 FOR x.fill=0 TO 4: sx=offset.x
    +x.fill*4
160 WINDOW#3, sx, sx+3, sy, sy+3
170 IF area(n)=1 THEN PAPER#3, colour ELSE PAPER#3, blank
180 CLS#3: n=n+1: IF other=1 THEN RETURN
190 NEXT: NEXT: RETURN
200 '
210 FOR d=1 TO 6: ORIGIN 0, 64*d: DRAW
    AWR 320, 0, 2: NEXT
220 FOR d=0 TO 5: ORIGIN 64*d, 64: DRAW
    RAWR 0, 320: NEXT
230 RETURN
240 '
250 FOR cycle=0 TO 4
260 FOR n=0 TO 4: LOCATE#1, offset.x
    +n*4+1, offset.y+1+cycle*4: PRINT
    INT#1, CHR$(65+n+cycle*5): NEXT
270 NEXT cycle: RETURN
280 '
290 IF area(x)=1 THEN area(x)=0 ELSE area(x)=1
300 other=1: n=x
310 sx=(x-INT((x-1)/5)*5-1)*4+offset.x
320 sy=(INT((x+4)/5)-1)*4+offset.y
330 WINDOW#3, sx, sx+3, sy, sy+3: PAPER#3, 2
340 FOR flash=1 TO 25: INK 2, flash: CLS#3: FOR cycle=1 TO 50: NEXT
    : NEXT
350 GOSUB 160: other=0
360 RETURN
370 '
```

```

380 '*** Main Program
390 GOSUB 80:GOSUB 130:total=0
400 GOSUB 210
410 GOSUB 250
420 PRINT"Which one now boss?";
430 w$=INKEY$:IF w$="" THEN 430 ELSE PRINT UPPER$(w$):number=ASC(UPPER$(w$))-64
440 IF w$="?" THEN 690
450 IF number<1 OR number>25 THEN PRINT CHR$(7)"Sorry boss!That one doesn't exist.":PRINT:GOTO 420 ELSE PRINT
460 x=number:GOSUB 290
470 IF number-5>0 THEN x=number-5:GOSUB 290
480 IF number+5<26 THEN x=number+5:GOSUB 290
490 IF number/5=INT(number/5) THEN 520
500 IF number+1<26 THEN x=number+1:GOSUB 290
510 IF (number-1)/5=INT((number-1)/5) THEN 530
520 IF number-1>0 THEN x=number-1:GOSUB 290
530 total=total+1:result=0
540 FOR sum=1 TO 25:result=result+area(sum):NEXT
550 IF result=25 THEN GOTO 590
560 PRINT#5,"Move # : "USING"###";total:GOTO 400
570 '
580 '*** Win response
590 CLS
600 WINDOW#6,30,30,4,25
610 PEN#6,2:PAPER#6,0
620 PRINT#6,"WE DID IT BOSS!!!"
630 FOR flash=0 TO 25:INK 2,flash:FOR pause=1 TO 200:NEXT:NEXT
640 PRINT#5,"Shall we try again boss?":
650 a$=INKEY$:IF a$="" THEN 650
660 IF UPPER$(a$)="Y" THEN CLS:CLS#5:GOTO 390 ELSE CLS:CLS#5:PRINT"Thank's boss! See you soon.":END
670 '
680 '*** Give-up response
690 CLS:PRINT"Too bad we couldn't do this job boss.":PRINT:PRINT"Maybe we could try again?"
700 PRINT:PRINT"Only"25-result"flagstones remainedunpainted.":PRINT:PRINT"For a total of"total"moves!":PRINT
710 IF (25-result)=1 AND total<21 THEN PRINT"Excellant result!":GOTO 640
720 IF (25-result)<=3 AND total<15 THEN PRINT"Could be improved!":GOTO 640
730 PRINT"Not a very exciting score boss!":GOTO 640
740 STOP
750 '
760 '*** Initializations
770 MODE 1:WIDTH 75:CALL &BC02
780 INK 0,13:INK 1,0:INK 2,26:INK 3,24
790 BORDER 13:PEN 1:PAPER 0:CLS
800 PEN#1,3:PEN#5,3
810 PAPER#1,1:PAPER#5,0
820 WINDOW#1,1,20,1,22
830 WINDOW#2,22,40,1,22
840 WINDOW#5,1,40,25,25
850 DEFINT a-z
860 DIM area(25)
870 colour=1:blank=0
880 offset.x=1:offset.y=2
890 title$=""
900 FOR effect=1 TO 10:title$=title$+CHR$(137)+CHR$(134):NEXT
910 LOCATE 10,2:PEN 3:PRINT title$
920 LOCATE 16,4:PRINT"PAINTOUT"
930 LOCATE 10,6:PRINT title$
940 LOCATE 1,8:PEN 1:PRINT"Poor Luigi!!":PRINT"He has been given the job of repainting the front flagstones of the Magician's Palace. Unfortunately these particular flagstones are bewitched and are playing a trick on him.
950 PRINT:PRINT"Every time that Luigi paints one, those that are beside it decide to change their state: if painted, they 'unpaint' themselves, and if unpainted they paint themselves."
960 PRINT:PRINT"Can you help Luigi beat the flagstones. (To give-up, press <?>)"
970 LOCATE 1,25:PRINT"Press <ENTER> key when you are ready.";
980 WHILE INKEY$="":WEND:CLS
990 WINDOW SWAP 2,0
1000 GOTO 390

```

YOUR AMSTRAD BOOK SOLUTION

All titles discounted by 10% for subscribers only

Title		Subscriber Price	Normal Price
Advanced User Guide		\$ 19.75	\$ 21.95
Adventure Games for the Amstrad		\$ 25.15	\$ 27.95
Amstrad Compendium		\$ 20.65	\$ 22.95
Amstrad Computing		\$ 21.55	\$ 23.95
Amstrad Games Book (Pitman/Ramshaw)		\$ 14.35	\$ 15.95
Amstrad Games Book (Melbourne House)	NEW	\$ 20.65	\$ 22.95
Amstrad Pentacle Adventure Creator	NEW	\$ 8.05	\$ 8.95
Amstrad Users Omnibus - 464/664/6128	NEW	\$ 17.95	\$ 19.95
Basic BASIC		\$ 11.45	\$ 12.75
Basic Programming on the Amstrad		\$ 22.45	\$ 24.95
Brainteasers for the Amstrad		\$ 19.75	\$ 21.95
Childs' Guide to the Amstrad Micro		\$ 9.85	\$ 10.95
Disc System, The Amstrad CPC 464	NEW	\$ 25.15	\$ 27.95
Dynamic Games for the Amstrad		\$ 17.95	\$ 19.95
Exploring Adventures on the Amstrad		\$ 21.55	\$ 23.95
Filing Systems And Databases for the Amstrad		\$ 26.95	\$ 29.95
Games and Graphics Programming - 464/664/6128	NEW	\$ 26.95	\$ 29.95
Graphics Programming Techniques	NEW	\$ 22.45	\$ 24.95
Ins and Outs of the Amstrad		\$ 20.65	\$ 22.95
Machine Code for Beginners on the Amstrad		\$ 17.95	\$ 19.95
Machine Language for the Absolute Beginner	NEW	\$ 20.65	\$ 22.95
Making Music on the 464/664	NEW	\$ 19.75	\$ 21.95
Master Machine Code on your 464/664	NEW	\$ 19.75	\$ 21.95
On the road to Artificial Intelligence		\$ 17.95	\$ 19.95
Pitman's First Book of Amstrad Games		\$ 11.65	\$ 12.95
Practical Programs for the 464		\$ 21.55	\$ 23.95
Programming the Amstrad CPC 464	NEW	\$ 17.95	\$ 19.95
Ready made Machine Language routines - 464/664	NEW	\$ 20.65	\$ 22.95
Structured Programming on the 464/664/6128	NEW	\$ 26.95	\$ 29.95
Whole Memory Guide	NEW	\$ 26.95	\$ 29.95
Working Amstrad		\$ 17.95	\$ 19.95
Writing Adventure Games on the 464/664	NEW	\$ 20.65	\$ 22.95
Your first Amstrad Program		\$ 20.65	\$ 22.95
40 Educational Games for the Amstrad		\$ 19.75	\$ 21.95
60 Programs for your Amstrad		\$ 19.75	\$ 21.95

How to Order

Send a list of the titles and quantities you require along with a cheque for the total **plus** \$5.00 postage and packing (regardless of the quantity you order) to:

STRATEGY PUBLICATIONS

Shop 2, 33 The Centreway, Blackburn Road, Mount Waverley, Victoria, 3149
 Bankcard or Mastercard orders accepted by phone on (03) 232 7055

FIREBIRD GOES CHEAP CHEAP

from Tony Blakemore

A series of games for \$7.98 each? It seemed awfully cheap, so I enquired and was told - No, it was not a sale special and Yes, \$7.98 was the retail price. Having got used to paying top dollar for any decent software for the Amstrad, I must say I was very wary of the low price.

Throwing caution to the wind I dipped into the ever diminishing reserves and bought a couple of titles - LOCOMOTION and THE WILD BUNCH - both by Firebird, a British Telecom subsidiary.

Being very surprised by the quality of the games and with Christmas in mind I bought the other titles a few days later. With one exception I would rate the games as excellent value for money and certainly hope that other software houses follow in producing lower priced software.

THE WILD BUNCH: Strategy/Adventure from Firebird. This is rather hard to classify, as the game contains elements of both. It is set in the old Wild West and you have a selection of different towns as start locations in your quest to track down The Wild Bunch. The game is mainly text with a few graphic screens to liven up the action. The sound is very good and though written entirely in Basic, should keep the younger adventurer occupied for many hours.

SUBSUNK: Adventure from Firebird. Set in a submerged submarine, SUBSUNK was written using The Quill adventure writer and is enhanced with a series of graphic screens. Not for the seasoned adventurer, but if you

would like to try your first adventure, SUBSUNK is for you. PS. Study the label for the first clue.

MR. FREEZE: Platform from Firebird. As an introduction to platform games, MR. FREEZE is excellent. Because of the lower price you do not get as many screens as the more expensive games, but there are still enough to contain the usual selection of hazards and baddies. I always have a soft spot for any game that lets me live for more than 30 seconds, and with this game I was able to make three or four screens with lives still intact. Very nice graphics and excellent sound make MR. FREEZE recommended buying.

SHORT FUSE: Platform from Firebird. Not being a seasoned player of platform games, I found SHORT FUSE difficult. I never get the hang of jumping onto moving platforms. The object of the game is to defuse a series of bombs placed in very difficult locations. With a bit of perseverance I managed a couple of screens and I am sure the better players will not find the game too difficult. The sound is so-so with interesting graphics. Not one of the better games, but not too bad.

NONTERRAQUEROUS: Shoot 'em up from Mastertronics. I don't know where this little gem has been hiding but what a great game. Plenty of baddies to shoot and annoying pests that get in the way when you are trying to move to another screen. Beautiful multicoloured locations and sprites make this game one of the most colourful I have seen. Walls of moving colour that destroy you at the slightest touch make movements around the screen hazardous to say the least. There are a thousand screens in this game and it should keep the "shoot 'em ups" happy for many hours. Roland keep running, you will never catch this one. Highly recommended.

LOCOMOTION: Mindbender from Mastertronics. A series of tiles that contain part of a rail track are arranged

in a random fashion on the screen, the object being to re-arrange them to enable the train to return to the station. It sounds easy but don't you believe it. LOCOMOTION is one of the most frustrating games that I have played. A panic key allows you to halt the train for a minute while you get the tracks arranged. It only seems to add to the tension. The graphics are excellent and I am sure this game will keep all ages enthralled for hours. Highly recommended.

CHILLER: Platform from Mastertronics. This left me for cold. The music and intro screen offer a lot of promise and that's about it. The graphics are C64 vintage and the music during the game is very irritating - still, you can't win them all.

FINDERS KEEPERS: Platform/Adventure/Strategy from Mastertronics. Has a bit of everything. Plenty of objects to find and trade. Multilevel platforms to rush around and one of the best mazes that you will find. The scrolling is very smooth, and the screen changes as you move around are very fast. There are lots of fairly benign baddies, more a nuisance than anything else, which help to keep you on the hop. The object of the game? I have yet to find out. Still, lots of fun if you like a not so serious Adventure/Strategy. Recommended.

I only hope that the software companies keep up the trend towards cheaper software. Certainly none of the games is in the classics class but how long can you play a game before you get sick of it? At \$7.98 they are terrific value.

Just as I finished this article, I discovered that Ozi-Soft are to release a range of classics that have not been seen on general release in Australia. Titles such as Galaxia, Fruity Frank and others by Kuma - titles that I was surprised not to see released many months ago. The best part is the price of \$9.95. I'll let you know what I think of them.

Computers in the Classroom

by Peter Norrish and Keith Saw

Hillman Primary School purchased five Amstrad CPC 464 computers in May 1985 and Cooloongup Primary School purchased five in August 1985. The computers were purchased by both schools for student and teacher use. Initially they were used by the students playing "Hangman", "Maths Invaders" and other educational software that was available. Since then there have been several developments which have been extremely exciting and innovative in using computers in a Primary School.

Teacher Inservice

Ten teachers from Hillman Primary School undertook a ten week computer course in using the Amstrad. This

course was conducted at Hillman school in June and the purpose was familiarisation with computers, an introduction to programming and an explanation of some of the capabilities of the CPC 464. All teachers considered such a course was imperative prior to using the computers in their own classroom.

Incidentally, teachers borrow the computers for their own use either on a nightly basis or for weekends.

Teacher Implementation and Classroom Use

Using a roster system, the computers are deployed around the classrooms for student use on each working day.

Whilst the classroom teacher is conducting normal lessons, students have an opportunity to use the computer either on a particular educational program or on a program designed to improve a particular skill, e.g. mathematics, spelling, social studies or science.

The computers have become a focal point in the classroom and teachers are extremely happy with the way children use them and how computers can be used as a classroom incentive. With the emphasis being "hands-on", the Amstrad computers are turned on at 8.15 a.m. each morning and are continually in use until the close of the school day.

School Interchange and Computer Use

During June 1985, Cooloongup students from Year 7 (11-12 year olds) and Year 7 students from Hillman Primary School met at Hillman School and worked together on a variety of programs. The interchange of ideas and the communication between the students from both Rockingham schools over 'Arnold' was terrific. Since the initial meeting there have been three other meetings lasting approximately two hours and concluding with a November meeting to evaluate and discuss various programs.

The benefits derived from such meetings are numerous and lead to the development of communication skills, an exchange of computer programming ideas, plus the social aspects of meeting other students with the common denominator being the Amstrad.

Student Computer Groups

Ten students from the senior section



Tony Beatty assisting Hillman Primary School students

of the schools meet once a week for additional computer instruction. It is at these sessions that students learn and experiment with programs and extend their own working knowledge of the machines.

Computer Support

To ensure maximum use of the Amstrad computers, both Coo loongup and Hillman Schools have spent money on purchasing a disc drive, a printer (very handy for writing reports), plus many blank tapes. In addition, the reference material available and distributed by Strategy Publications has been purchased and forms a reference library that can be used by students and teachers to extend themselves and to assist them when writing programs. Educational software has been developed for use in all core subjects.

Parent Involvement

Parents have been involved in two major ways since our schools introduced computers. Several mothers have volunteered their services to type up programs for use by students with quite a degree of success. Secondly, two parent sessions have been undertaken by one of the Hillman School teachers, Mr. Tony Beatty, to explain how computers are used in the class and in the school. In fact, parents became so involved in using the computers that it

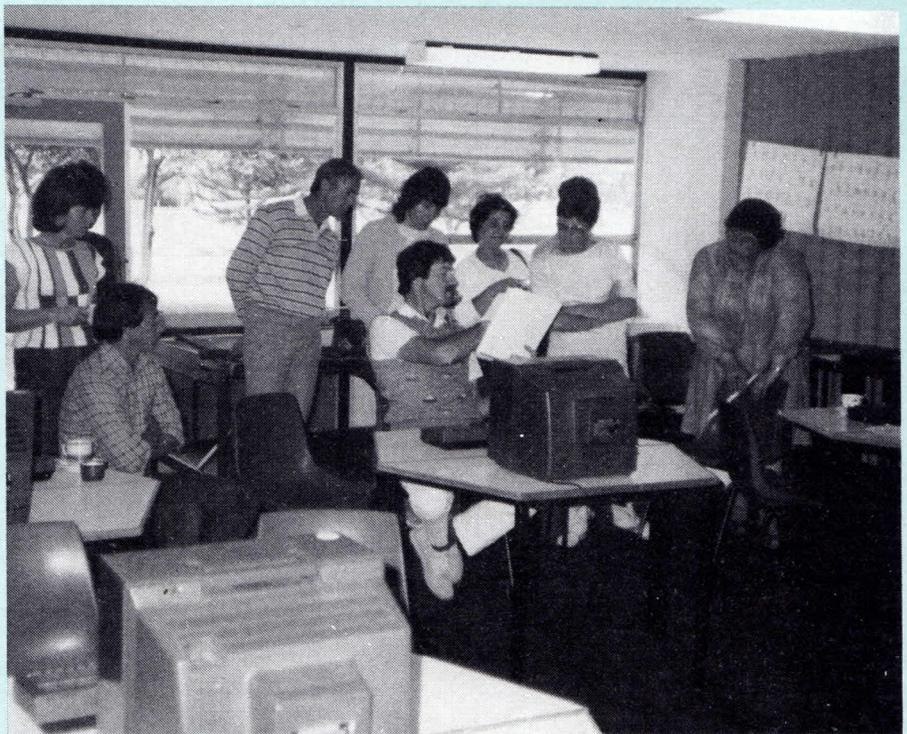

Peter Norrish familiarising parents with Amstrad concepts

was difficult to get them out of the room at the end of the meeting!

Conclusion

Since having the Amstrad computers at Hillman and Coo loongup, we have found that they are more than 'adequate' for school use. In fact, the capabilities of these computers ensure that all aspects of computer education can be undertaken with a great deal of

confidence in any school. We would definitely recommend that any school (Primary or Secondary) considering the purchase of a versatile and robust classroom computer would not go far wrong in buying an Amstrad CPC 464.

Keith Saw is a Year 7 teacher at Coo loongup Primary School.

Peter Norrish is the Deputy Principal at Hillman Primary School.

To all Subscribers - we thank you for your enthusiastic response to The Amstrad User during 1985 and look forward to even better and more exciting pages over the next 12 months.

As a special "thank you" for your continued support, we have exclusively commissioned the printing of a new book called "High Energy Programs for the Amstrad". It contains an exceptionally good game of Backgammon, with Tank Attack and Poker amongst others, and utilities including a Disc Label Printer, a Hi-res Screen dump and a Disassembler.

It will probably be released to bookshops later this year at a price of \$8.95 - but is available **FREE OF CHARGE** to people who had an existing subscription at 31st December 1985 and who renew that subscription when due. Further details will be sent with a renewal reminder at the appropriate time.

***Now you can look after
your copies of
THE AMSTRAD USER
in a smart white and
silver binder that will
grace any bookshelf.***

***The Binder, which houses 12
copies of the magazine, costs
\$12.95 (including postage in a
special protective box) and
comes with matching volume
number decals.***

***Only 250 have been produced
- so order now to be sure of
protecting your collection.***

***Strategy Publications
Suite 1, 33 The Centreway
Mt. Waverley, Victoria 3149
Telephone: 03 - 232 7055
Bankcard or Mastercard accepted***

Guide to a 5.25" Disc Drive Power Supply

by Jan Lotocky

Having started to write this article about voltage drops in extension leads and in power supplies, I got too carried away mentioning how these effects are produced and related by resistance, impedance, reactance and inductance. This could be too confusing for many and people buying this magazine certainly do not expect a course in electronics, as there are many good books available from your bookstore.

The article is divided into two sections, the first as a guide to the novice in computing with little back-ground knowledge in electronics and save them the pit-falls others have fallen into, including myself. The second part is for the experienced project builder

Many people bought 5.25" drives without power supplies. Some people have coupled (piggy-backed) their 5.25" to the supply of the 3 inch drive and others have used power supplies not intended for that particular purpose. Power supplies designed to run disc drives have good voltage regulation allowing for the input voltage fluctuation maintaining a constant voltage output and good filtering. To some degree they reject most voltage spikes that get into the disc drive and are designed to run either one or more drives.

By coupling into the 3 inch disc drive power supply there is additional load and heat on the components trying to deliver the extra current and in time a device could fail. When it does it depends on just how lucky you are, either one or two drives destroyed.

Sure, some people are piggy-backing and getting away with it at the moment but many warnings have already shown

up. In clubs, where a lot of extension leads are used creating voltage drops along them, the 5.25" drive usually does not function properly. The other signs are trouble in formatting discs, discs losing data, noticeably slower access time in running a program from disc and many occasions when, whilst saving data onto a disc, voltage interference entering the disc drive corrupts the data. For example, when the air-conditioner or washing machine is suddenly turned on.

"A LITTLE KNOWLEDGE IS A DANGEROUS THING". This saying is commonly used in the electronics industry to other people who have attempted to repair or modify their equipment and were later burdened with the extra expense to be paid to a technician for repairs.

Another favourite saying - *"NO KNOWLEDGE IS SAFE"*. If you have no knowledge at all about drives and supplies then you wouldn't be fiddling with them and the best advice when purchasing your 5.25" drive is to buy a supply designed for that particular purpose thus reducing the amount of failures described.

The rest of this article is a guide for experienced project builders with adequate knowledge in electronics should they wish to build their own power supply either in a similar manner or to their own requirements.

I wanted a power supply to be compact yet run two drives plus power my portable "2 meter". In addition, as there are electronic projects starting to

appear in magazines as add-ons for the "AMSTRAD", I didn't want to build a separate supply for each unit as my table is already cluttered with books, discs etc. I had a spare box in which to build the power supply. I worked out how much power my add ons will draw and assumed the box to be large enough to house the transformer required. Mentally I already had the cct. diagram in my head and all I had to do was chase the components. Shopping around I came against a brick wall for the required transformer 7.5 & 15/80VA to be able to handle the current I wanted to draw. Back to the drawing board. This time I decided to use the low profile FERGUSON PL 15/60VA and thus design or should I say assemble the required circuitry around it. This transformer is already encapsulated in an earth shield thus minimizing stray flux and critical layout. My next thought was the linear voltage regulators - the most concerning was the 5 volt regulator. I drew up a rough cct. and started to work out the power dissipated in the device. I worked out the worst possible extreme on the 12V. regulator being 37 watts, 5V. regulator being 65 watts - this was too high on the 5V. device but if the 5V. regulator input is coupled to the 12V. regulator output, then the output would then be 28 watts.

I measured the current drawn in the 5.25" drive and found it to be 340 mA idle current, peaking to 710 mA when fully engaged. Now I could work out the maximum number of drives that could be used with low temperature on the heat sink. I worked it out to be THREE drives and the temperature on this heat sink to be under 40 deg.C. which was well into the guide from the

data, (150 deg.C. before thermal shut down occurs). So if three drives are used from this supply the dissipated power worked out from the worst extreme power calculated is lowered to the 12V. regulator fluctuating from 19.5 watts to 9.5 watts and the 5V regulator being 15 watts, so now you can work out the size of the heat sink required to dissipate the heat given off.

The cct. is simple consisting of a transformer, bridge rectifier, filter capacitor and an IC voltage regulator. This design makes allowances for the way the supply is to be used. These three terminal POSITIVE VOLTAGE REGULATORS are excellent for TTL projects and Microprocessor power supplies. Also by using these voltage regulators a lot of other devices are omitted and all that is required is a good DC filtered input voltage. If used within the manufacturer's specifications, the reliability of these devices are indestructible because of internal current limiting and thermal shutdown. They require a minimum voltage on the input to be 3 volts higher for good regulation and heat dissipation. Although their input voltages can be up to 30 volts, much power is dissipated as heat if higher input voltages are used and large

currents be drawn from them.

The 3rd voltage regulator is the adjustable type and its output voltage can be pre-set to any desired voltage, the nominal value being 1.5 to 18V. Between the ground and adjust terminal a multiple switch with pre-set resistors (2K2) can be inserted to give the required outputs i.e. 6V, 9V, 12V.

If more than two drives are to be used for long periods of time or the older type drive used (they draw more current) I advise the use of "CCT.B" with the proper transformer which I have substituted (being out of stock at the time). As you can see an extra bridge rectifier and capacitor is used and only a minor modification made to the layout. The rest of the circuitry is the same as in "CCT.A".

BRIEF CCT. DESCRIPTION

240V AC entering the transformer is stepped down to 15V AC. The bridge rectifier rectifies the AC to DC and the storage filter capacitor smooths this voltage. This high filtered DC voltage is regulated by the IC REGULATORS thus the output is constant regardless of whether the input voltage fluctuates. For the disc drive loads, the TOTAL CURRENT is drawn from IC2, and some of this current is branched off to

IC1. IC3 is independent to the others, and the current being drawn from it depends on its rating and the load already on the VA of the transformer.

For this cct., a 6 to 10 AMP bridge can be used - the electrolytic 4700 to 5600 micro farads 35 or 50 volts. IC1 and IC2 are 5 AMP rated -78H05 and 78H12. IC3 can be 317K 1.5 AMP rated or 350K 3 AMP rated. All resistors are 1/2 watt, tantalums 25 volts for the variable output, and 16 volts for the other outputs. Standard LEDs can be used if required.

Looking at the cct. diagram you'll notice a 4 amp fuse inserted in the secondary and may wonder why. As stated these regulators have foldback current. The transformer is rated at 4 amps at this voltage, and IC1 & IC2 are 5 amp rated, thus should extra load be drawn from IC3 when IC1 & IC2 are loaded or vice versa - the fuse should blow preventing overload.

By now constructors should have worked out the values if a supply for one drive is assembled i.e. 1 amp rating for the transformer, 1.5 amp bridge, 2200 micro farad filter capacitor and the positive regulators being 1 amp min. But wait, IC1 draws current from IC2, thus if used in this configuration IC2 could be too heavily loaded. So the

CCT.A

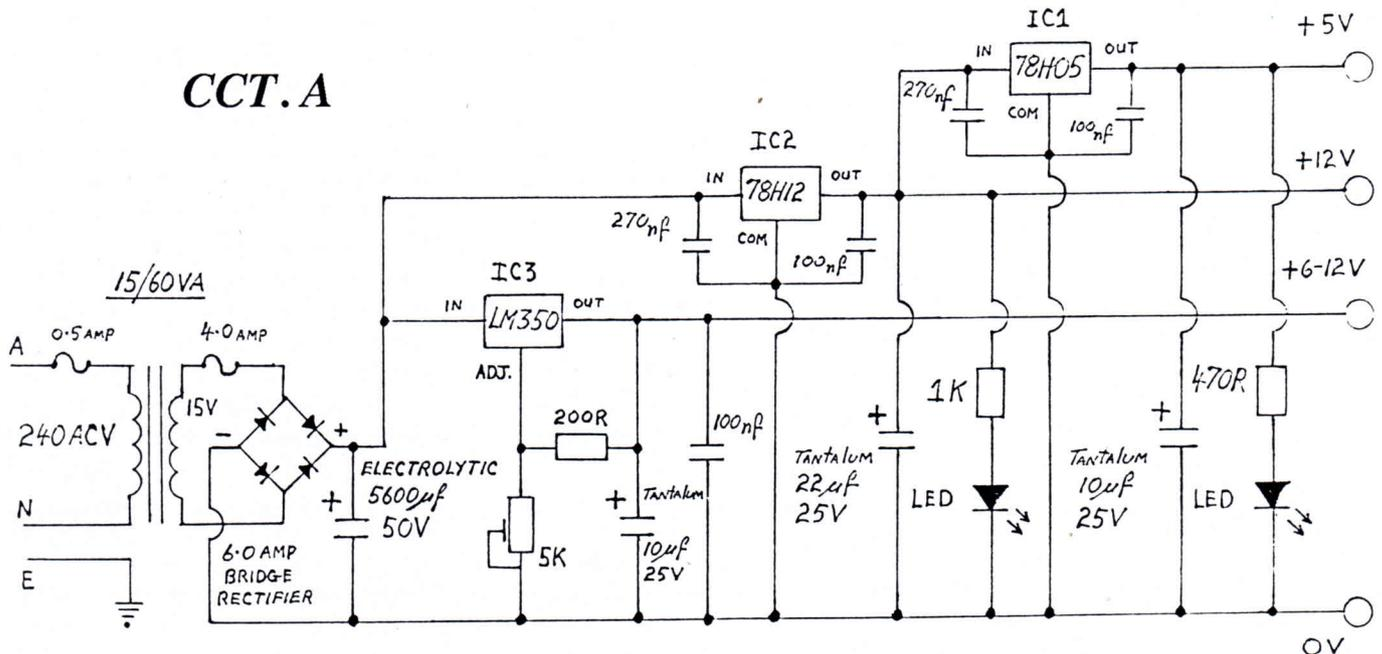

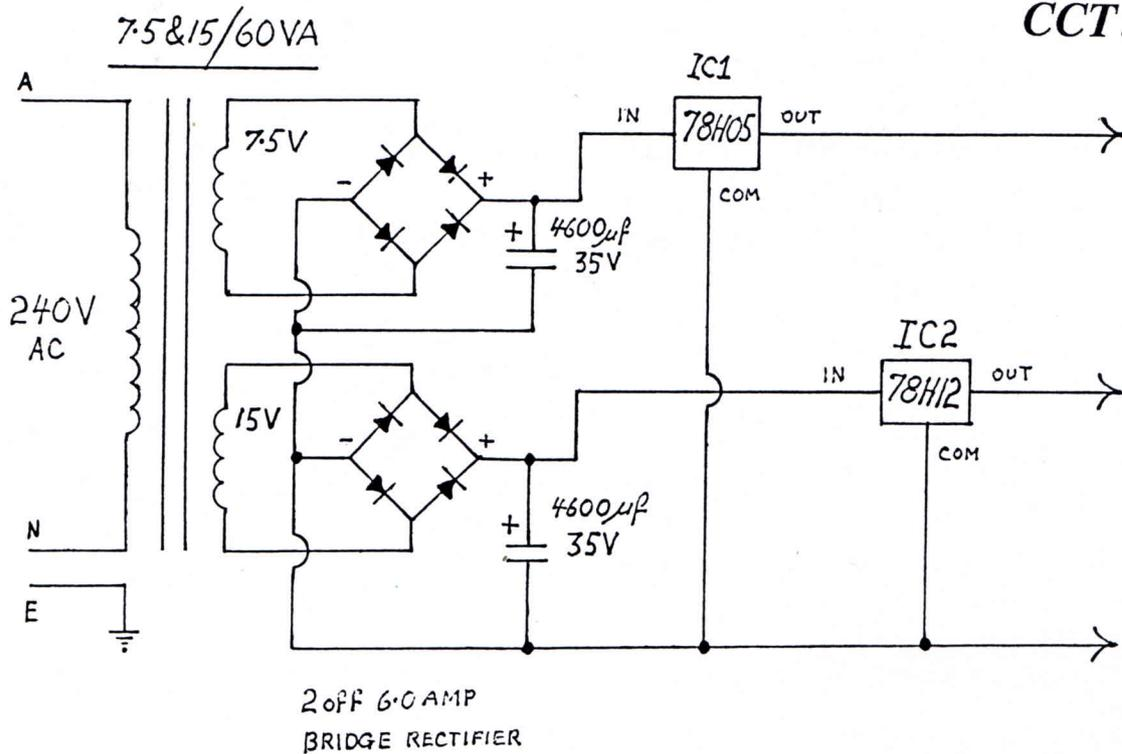

input of IC1 is removed and joined to the input of IC2. Alternatively the same configuration may be used with the TO-3 package regulators rated at 1.5 amp each.

Before going into construction thought must be given to a number of points. How many drives do you intend to run? Do you require the variable voltage cct? and if you do, how much current will be drawn? What is the total current and will the consumption be at the same time?

If heavy current is drawn the transformer will also get hot and adequate ventilation in the box must be provided. Thought also has to be given to whether you intend to use a lead output passing through the grommet and how many times will the plug be inserted and removed from the drive. Is the supply going to be transported? Do you require output sockets and where should they be placed? (i.e. for the drives at the back of the supply and the variable output in the front). Don't forget the little "FEET" which should be at least 1 cm high, to allow air to circulate around the box. The other

main thought is a switch on the primary if required, but most important a switch on the output. The reason being if your drives are connected and you switch on the 240V, there is a sudden surge of high voltage and at this split micro second before the voltage regulators have time to control the output, the voltage could get into the drives and.....*!*!

CONSTRUCTION

Almost all of the components are inserted under the heat sink. The side view of the heat sink is a wide "H" with a series of vertical fins, the end fins have the extension mounts. Other heat sinks may be adapted. The extra hardware required are lugs of three sizes and 2 or 3 x 6 lug tag strips. The reason for use of the TO-3 package voltage regulators was to simplify construction and eliminate the use of a PC board. Put heat transfer compound to both sides on the mica insulator washer then attach the washer to the IC regulator, mount the IC onto the heat sink. Pass the fixing screws through the top of the regulator and insert a "T"

insulating bush on each screw. Insert a thin metal washer on top of the insulating bush and tighten the nut making sure the other terminals are centered in the slot of the heat sink. Cut some heavy insulation (pvc tube) and fit onto the leads allowing room for the thickness of two lugs to be soldered. Check with a multimeter for infinite resistance between the fixing screws and heat sink (scratch some of the anodizing off the heat sink and insert the probe onto that point as the anodizing compound is none conductive). Check with the meter on each end of the fixing screws for a reading of 0.01 ohms. Assuming all is OK follow the diagram and use low resistive wire able to carry the current required i.e. figure 8 flex, crimp the lugs well, and use lugs 1/16" hole to be soldered onto the other terminals. Allow the ends of the input and output leads to be at least 8" in length - they can be trimmed to size when inserted into box. Position the capacitors in place using the other thin lugs or solder onto the required lugs already inserted - taking care of their polarity. The other

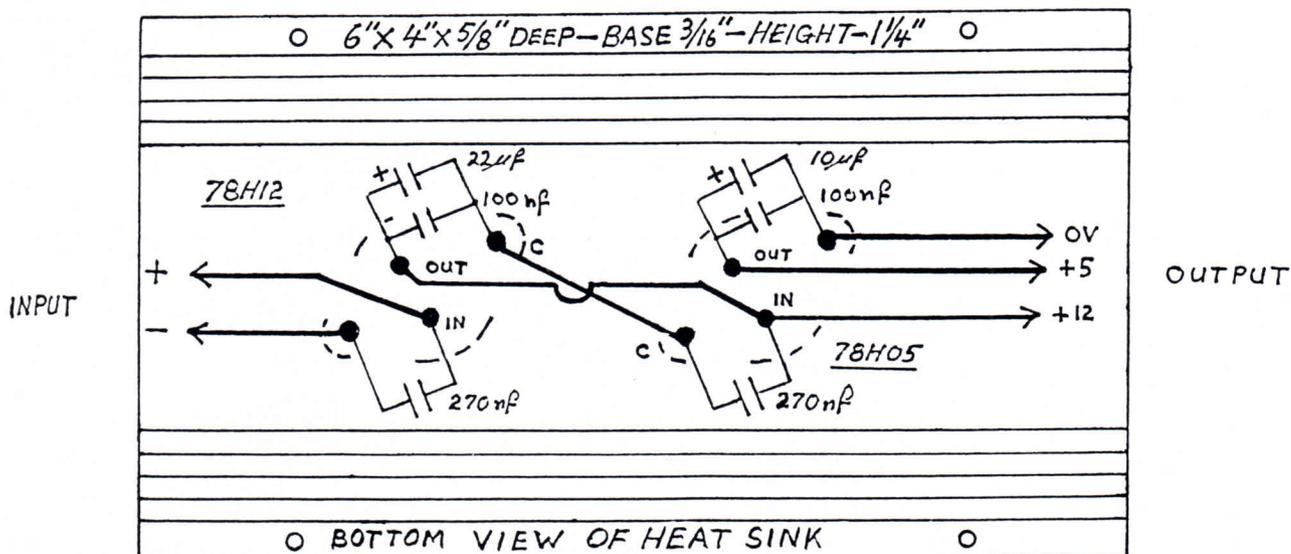

Diagram A

lugs are fixed with nuts on the fixing screws. (NOTE: Diagram A is only for drive supply).

The capacitors across the input of the voltage regulators are inserted with short leads at the terminals to maintain stability should the filter capacitor connection wire length exceed 2 inches. These capacitors are the miniature disc or plate ceramic type. The value of the capacitor can be 270 nano farads or higher.

The 100 nano farad capacitor across

the output is connected in the same way. The capacitor in this position reduces the high frequency noise and improves the transient response.

Tantalum capacitors were chosen on the outputs because of their low leakage and small size. These may be inserted on the output terminals on the voltage regulators or at the output terminals on the supply.

That's it - testing can be carried out before fixing the heat sink to the required position on the box. Be sure if

heavy load is applied, sink the bridge rectifier if it is of that type. If the tests prove successful, position the heat sink to the box and measure and mark the position of clearance holes (nominal 1/2" centers from each end of the heat sink) to pass the leads through etc. **MAKE SURE THE BOX IS WELL EARTHED.**

Well, good luck - I'm being called on the air waves.....QRZ.....THIS IS VK3ZGK.....

How many



did you find?

Result of the November Competition to "Win an Amstrad Library"

The answers received ranged from 20 to 97 appearances of the word AMSTRAD. There was no secret - it just required a sharp eye and, in some cases, the ability to read very small print. The Amstrad Omnibus for example had 5, albeit 3 were very small but legible. Some should have been there (eg. picture of machine on Amstrad Machine Language for the Absolute Beginner) but weren't. As there were some borderline cases, our final, irrevocable, no-correspondence-or-telephone-calls decision was to accept a figure in the range of 81 to 84.

The envelope to be drawn from that bundle came from:

J.P. and S.M. WODE of WARWICK in Queensland

Congratulations and let us know by phone (after 13th January 1986) which ten books you would like. Our thanks to all who entered.

THE ENGLISH AMSTRAD USER

(Amstrad Computer User)

In view of the increased demand for this publication, Strategy Publications is now offering new 12 month subscriptions.

There will be no restrictions on the starting date for your subscription. This means you can ask us to commence your 12 issue subscription from any month since January 1985. It's your choice, just make it clear on the form below, but ring us first if starting before July 1985.

The cost of the 12 issues including delivery to your home will be \$47.50, but a word of warning - this magazine is very often in short supply in Australia (as many users will know!) so will only be supplied on a strict first come first served basis.

Secure your copies now by telephone or by completing and returning the form below.

Strategy Publications, Suite 1, 33 The Centreway, Mt. Waverley,
Victoria 3149
(Tel: 03 - 232 7055)

Please enrol me for a 12 issue subscription to the English Amstrad User starting from
issue.....(month/year) at a cost of \$47.50 including postage.
In addition I would like the following back copies if available at \$4.50 each (incl p&p)

..... (month/year)
I enclose a cheque/please debit my Bankcard or Mastercard number:
..... (Expiry Date.....) for \$.....

Signed..... (Please allow 21 days for first delivery)

Telephone orders are accepted for payment by Bankcard or Mastercard

Space Explorer

An Educational Game from Andrew Halsey

1986 is the year for Halley's Comet, named after the English astronomer and mathematician Edmund Halley (1656 - 1742) who predicted the return of the comet. So it is fitting that we have a program to provide more information about our solar system. It could be especially useful to our younger readers who, by plotting a co-ordinate, are transported to a planet and provided certain information to be retained for a later quiz.

Of course, you can cheat and go straight to the quiz - but then you won't learn much and probably get a low score. So visit the planets first. As with most pieces of software in this magazine, Space Explorer provides an opportunity for enhancements, for example, sound can be added or the colours improved as this was originally developed for a green screen CPC464.

The program is preceded by an optional loader.

```
5 INK 0,1:BORDER 1
10 CLS
20 MODE 1
30 FOR A=0 TO 26
40 INK 0,A
50 FOR T=1 TO 100:NEXT
60 NEXT A
70 FOR T=1 TO 100:NEXT
80 INK 0,0
90 FOR C=0 TO 26
100 BORDER C
110 FOR T=1 TO 100:NEXT
120 NEXT
130 FOR A= 1 TO 15
140 PEN A
150 PRINT TAB(6);" SPACE EXPLORER
    NOW LOADING"
160 FOR T=1 TO 100:NEXT
170 NEXT
180 CHAIN "!SPACE"
```

```
10 REM *****
*
20 REM *PROG NAME:SPACE EXPLORER
*
30 REM *AUTHOR:ANDREW HALSEY****
*
40 REM *VERSION 1:6*****
*
50 REM *DATE 28\4\1985*****
*
60 REM *****
*
70 REM *****
*
400 REM INTRODUCTION
410 BORDER 1
420 PEN 13:INK 0,1
430 MODE 1
440 C1=1
450 PRINT #1, CHR$(206);
460 IF C1=1000 THEN 490
470 C1=C1+1
480 GOTO 450
490 WINDOW 10,30,7,18
500 A=0
510 ENV 1,100,1,3
520 ENT 1,100,-2,3
530 SOUND 1,284,300,1,1,1
540 PRINT CHR$(13)
550 IF A=22 THEN 580
560 A=A+1
570 GOTO 540
580 PAPER 13
590 PEN 0
600 PRINT
610 PRINT TAB(3)"SPACE EXPLORER "
620 PRINT
630 PRINT TAB(9)"BY"
640 PRINT
650 PRINT TAB(5)"ANDREW HALSEY"
660 PRINT
670 PRINT TAB(7)"PRESS I "
680 PRINT
690 PRINT TAB(3)"FOR INSTRUCTIONS
"
```

```

700 PRINT
710 PRINT TAB(5)"P FOR PLAY"
720 H$=INKEY$
730 IF H$="I" OR H$="i" THEN GOSU
    B 2270
740 IF H$="P" OR H$="p" THEN 760
750 GOTO 720
760 REM MAP
770 MODE 1: INK 0,1: INK 1,24
780 BORDER 22
790 CLG
800 PEN 13: PAPER 0
810 PRINT TAB(10);" PLEASE STUDY
    THIS"
820 FOR a=40 TO 500 STEP 50
830 FOR b=40 TO 500 STEP 50
840 PLOT 40,b
850 PLOT a,40
860 NEXT
870 NEXT
880 FOR x=40 TO 500 STEP 50
890 PLOT x,90
900 PLOT x,140
910 PLOT x,190
920 PLOT x,240
930 PLOT x,290
940 PLOT x,340
950 PLOT x,390
960 NEXT
970 TAG
980 MOVE 390,90
990 PRINT CHR$(231);
1000 MOVE 190,240
1010 PRINT CHR$(231);
1020 MOVE 290,106
1030 PRINT CHR$(231);
1040 MOVE 390,190
1050 PRINT CHR$(231);
1060 MOVE 90,240
1070 PRINT CHR$(231);
1080 MOVE 40,90
1090 PRINT CHR$(231);
1100 MOVE 90,140
1110 PRINT CHR$(231);
1120 MOVE 140,90
1130 PRINT CHR$(231);
1140 MOVE 90,290
1150 PRINT CHR$(231);
1160 MOVE 300,300:PRINT CHR$(230);
1170 MOVE 35,35
1180 PRINT"a";
1190 MOVE 85,35
1200 PRINT"b";
1210 MOVE 135,35
1220 PRINT"c";
1230 MOVE 185,35
1240 PRINT"d";
1250 MOVE 235,35
1260 PRINT"e";
1270 MOVE 285,35
1280 PRINT"f";
1290 MOVE 335,35
1300 PRINT"g";
1310 MOVE 385,35
1320 PRINT"h";
1330 MOVE 435,35
1340 PRINT"i";
1350 MOVE 485,35
1360 PRINT"j";
1370 MOVE 20,50
1380 PRINT"1";
1390 MOVE 20,90
1400 PRINT"2";
1410 MOVE 20,140
1420 PRINT"3";
1430 MOVE 20,190
1440 PRINT"4";
1450 MOVE 20,240
1460 PRINT"5";
1470 MOVE 20,290
1480 PRINT"6";
1490 MOVE 20,340
1500 PRINT"7";
1510 MOVE 20,390
1520 PRINT"8";
1530 MOVE 0,350
1540 MOVE 490,50
1550 PEN 1
1560 FOR T=1 TO 5000:NEXT
1570 ENV 1,50,2,10
1580 SOUND 1,284,1000,1,1
1590 TAGOFF
1600 FOR T=1 TO 5000
1610 NEXT
1620 REM PLOT CO-ORDINATES
1630 BORDER 18
1640 CLS
1650 PRINT CHR$(7)
1660 INPUT" PLOT HORIZONTAL CO-ORDI
    NATE PLEASE [1-8]";H
1670 PRINT CHR$(7)
1680 INPUT " PLOT VERTICLE CO-ORDIN
    ATE PLEASE [a-j]";V$
1690 REM COUNTDOWN
1700 CLS
1710 MODE 0
1720 PRINT"PREPARE TO BLAST OFF"
1730 PRINT
1740 PRINT TAB(4);"GOOD LUCK"
1750 FOR T=1 TO 1000:NEXT
1760 CLS

```

```

1770 FOR A=10 TO 1 STEP -1
1780 LOCATE 10,10
1790 PRINT TAB(10);A;:FOR t=1 TO 2
    00:NEXT:CLS
1800 PAPER A
1810 PRINT CHR$(7)
1820 FOR T=1 TO 1000
1830 NEXT T
1840 IF A=4 THEN PEN 0
1850 NEXT
1860 REM BLASTOFF
1870 PEN 13
1880 ENV 1,1,18,0,11,0,10:ENT 1,10
    ,2,2:SOUND 130,0,400,13,3,0,3
    1
1890 PRINT
1900 INK 0,9
1910 MODE 0
1920 BORDER 0
1930 PAPER 0
1940 CLG
1950 TAG
1960 MOVE 250,30
1970 PRINT CHR$(215);
1980 PRINT CHR$(214);
1990 MOVE 265,40
2000 PRINT CHR$(239);
2010 FOR t=1 TO 1000:NEXT
2020 CALL &BD19
2030 MOVE 265,40
2040 PRINT CHR$(32);
2050 FOR a=50 TO 350
2060 MOVE 265,a
2070 PRINT CHR$(239);
2080 NEXT
2090 FOR d=50 TO 335
2100 MOVE 265,d
2110 PRINT CHR$(32);
2120 NEXT
2130 CLS
2140 MODE 2
2150 IF H=2 AND V$="A" OR V$="a" T
    HEN GOSUB 2500
2160 IF H=2 AND V$="H" OR V$="h" T
    HEN GOSUB 4230
2170 IF H=3 AND V$="B" OR V$="b" T
    HEN GOSUB 2800
2180 IF H=5 AND V$="B"OR V$="b" TH
    EN GOSUB 3000
2190 IF H=6 AND V$="b" OR V$="B" T
    HEN GOSUB 3190
2200 IF H=2 AND V$="C" OR V$="c" T
    HEN GOSUB 3380
2210 IF H=5 AND V$="D" OR V$="d" T
    HEN GOSUB 3570
2220 IF H=2 AND V$="F" OR V$="f" T
    HEN GOSUB 3750
2230 IF H=4 AND V$="H" OR V$="h" T
    HEN GOSUB 4050
2240 IF H=6 AND V$="F" OR V$="f" T
    HEN 4510
2250 IF V$<>"A" OR V$<>"a" OR V$<
    >"B" OR V$<>"b" OR V$<>"C" OR
    V$<>"c" OR V$<>"D" OR V$<>"d
    " OR V$<>"F" OR V$<>"f" OR V$
    <>"H" OR V$<>"h" AND H<>2 OR
    H<>3 OR H<>5 OR H<>6 OR H<>4
    THEN 4410
2260 REM INSTRUCTIONS
2270 MODE 1
2280 CLS
2290 PRINT
2300 PRINT"YOU ARE A QUARK THAT WI
    SHES TO BECOME A"
2310 PRINT"MEMBER OF THE BROTHERHO
    OD OF QUARKS"
2320 PRINT"TO BECOME A MEMBER YOU
    MUST EXPLORE THE"
2330 PRINT"EARTH SOLAR SYSTEM.YOU
    WILL PASS THROUGH A TIME WARP
    TO GET THERE AND TO GET BACK"
2340 PRINT" THIS IS REPRESENTED BY
    AN OPEN CIRCLE "
2350 PRINT"ON THE MAP.A CLOSE CIRC
    LE REPRESENTS A"
2360 PRINT"PLANET.TO GET TO A PLAN
    ET OR THE TIME "
2370 PRINT"WARP YOU MUST PLOT ITS
    CO-ORDINATES ,"
2380 PRINT"FOR EXAMPLE 7D.WHEN ANS
    WERING QUESTIONS"
2390 PRINT"PRESS THE ENTER KEY AFT
    ER YOU HAVE TYPED THE RESPONCE
    "
2400 PRINT
2410 PRINT"THIS IS GENERAL AMSOFT
    SIGNING OFF!"
2420 PRINT
2430 PRINT" PRESS SPACE TO CONTINU
    E....."
2440 M$=INKEY$
2450 IF M$=" " THEN MODE 1:GOSUB
    2480
2460 GOTO 2440
2470 REM EARTH
2480 BORDER 1:INK 0,1:INK 1,24
2490 GOSUB 770
2500 MODE 1
2510 INK 0,0:BORDER 0
2520 CLS
2530 f=INT(RND*500)
2540 g=INT(RND*700)

```

```

2550 PLOT f,g
2560 PLOT g,f
2570 IF c2=150 THEN 2600
2580 c2=c2+1
2590 GOTO 2530
2600 FOR a=1 TO 360
2610 ORIGIN 300,200
2620 DRAW 40*COS(a),40*SIN(A)
2630 NEXT
2640 PRINT
2650 PRINT
2660 PEN 13
2670 PRINT TAB(15);"The EARTH"
2680 INK 0,1:BORDER 1
2690 FOR a=1 TO 360
2700 ORIGIN 200,200
2710 DRAW 10*COS(a),10*SIN(a)
2720 NEXT
2730 PRINT"THE EARTH IS THE ONLY P
LANET WHERE LIFE FORMS(PEOPLE
) EXIST.IT HAS ONLY ONE MOON.T
HE MOON'S GRAVITY IS 1/6 OF T
HE EARTHS.THE EARTH ITSELF IS
MADE OUT OF MOLTEN ROCK"
2740 TAG:MOVE 0,60
2750 PRINT"PRESS SPACE TO CONTINUE
.....";:TAGOFF
2760 M$=INKEY$
2770 IF M$=" " THEN 770
2780 GOTO 2760
2790 REM JUPITER
2800 MODE 2:INK 0,0: BORDER 0:FOR
s=1 TO 150:z=INT(RND*700)
2810 x=INT(RND*500)
2820 PLOT x,z
2830 PLOT z,x
2840 NEXT
2850 FOR a=1 TO 360
2860 ORIGIN 320,200
2870 DRAW 100*COS(a),100*SIN(A)
2880 NEXT
2890 TAG:MOVE 1,190
2900 PRINT "JUPITER";:TAGOFF
2910 FOR T=1 TO 1000:NEXT
2920 BORDER 5:PEN 13
2930 PRINT:PRINT
2940 PRINT USING "&###,##,##,##";"
JUPITER IS THE LARGEST PLANET
IN THIS SOLAR SYSTEM.IT HAS
ABOUT 13 MOONS.ON THE PLANET
IT SELF,THERE IS ONE LARGE RE
D SPOT.JUPITER IS VERY COLD"
2950 PRINT:PRINT TAB(22);"PRESS SP
ACE TO CONTINUE ....."
2960 M$=INKEY$
2970 IF M$=" " THEN 770
2980 GOTO 2960
2990 REM NEPTUNE
3000 INK 0,0:MODE 2:BORDER 0:
3010 FOR L=1 TO 150
3020 X=INT(RND*700)
3030 Z=INT(RND*500)
3040 PLOT X,Z
3050 PLOT Z,X
3060 NEXT
3070 FOR A1=1 TO 360
3080 ORIGIN 320,200
3090 DRAW 70*COS(A1),70*SIN (A1)
3100 NEXT A1
3110 PEN 13
3120 PRINT TAB(35);"NEPTUNE"
3130 PRINT:PRINT USING"&###,##,##,
##,##";"NEPTUNE WAS DISCOVERE
D IN 1846.IT IS A GREENISH CO
LOUR.IT HAS TWO MOONS"
3140 PRINT:PRINT TAB(22);"PRESS SP
ACE TO CONTINUE....."
3150 M$=INKEY$
3160 IF M$=" " THEN 770
3170 GOTO 3150
3180 REM MERCURY
3190 MODE 2:INK 0,0:BORDER 0
3200 FOR W=1 TO 150
3210 X=INT(RND*700)
3220 Z=INT(RND*500)
3230 PLOT X,Z
3240 PLOT Z,X
3250 NEXT
3260 FOR A=1 TO 360
3270 ORIGIN 320,200
3280 DRAW 50*COS(A),50*SIN(A)
3290 NEXT
3300 PRINT
3310 PRINT TAB(35);"MERCURY"
3320 PRINT USING"&###,##,##,##";"M
ERCURY IS THE CLOSEST PLANET
TO THE SUN.IT IS ALSO THE SMA
LLEST.THIS PLANET HAS NO MOON
S."
3330 PRINT:PRINT TAB(22);"PRESS SP
ACE TO CONTINUE....."
3340 M$=INKEY$
3350 IF M$=" " THEN 770
3360 GOTO 3340
3370 REM VENUS
3380 MODE 2:INK 0,0:BORDER 0
3390 FOR H=1 TO 150
3400 Z=INT(RND*700)
3410 X=INT(RND*500)
3420 PLOT Z,X
3430 PLOT X,Z
3440 NEXT

```

```

3450 FOR A= 1 TO 360
3460 ORIGIN 320,200
3470 DRAW 70*COS(A),70*SIN(A)
3480 NEXT
3490 PRINT
3500 PRINT TAB(35);"VENUS"
3510 PRINT USING"&###,##,##,##";"V
ENUS IS THE SAME SIZE AS THE
EARTH. IT IS ALSO CALLED 'THE
EVENING STAR'. THIS IS THE ONL
Y PLANET TO ROTATE BACKWARDS"
3520 PRINT:PRINT TAB(22);"PRESS SP
ACE TO CONTINUE....."
3530 M$=INKEY$
3540 IF M$=" " THEN 770
3550 GOTO 3530
3560 REM MARS
3570 MODE 2:INK 0,0:BORDER 0
3580 FOR D=1 TO 150
3590 Z=INT(RND*700)
3600 X=INT(RND*500)
3610 PLOT Z,X
3620 PLOT X,Z
3630 NEXT
3640 FOR A= 1 TO 360
3650 ORIGIN 230,200
3660 DRAW 35*COS(A),35*SIN(A)
3670 NEXT
3680 PRINT TAB(40);"MARS"
3690 PRINT USING"&###,##,##,##";"M
ARS IS KNOWN AS THE 'RED PLAN
ET'. IT CAN BE SEEN WITH OUT A
TELESCOPE. THERE ARE NO SIGNS
OF LIFE ON MARS . MARS HAS T
WO MOONS"
3700 PRINT:PRINT TAB(22);"PRESS SP
ACE TO CONTINUE....."
3710 M$=INKEY$
3720 IF M$=" " THEN 770
3730 GOTO 3710
3740 REM SATURN
3750 MODE 2:INK 0,0:BORDER 0
3760 FOR S=1 TO 150
3770 Z=INT(RND*700)
3780 X=INT(RND*500)
3790 PLOT Z,X
3800 PLOT X,Z
3810 NEXT
3820 FOR A=1 TO 360
3830 ORIGIN 320,200
3840 DRAW 90*COS(A),90*SIN(A)
3850 NEXT
3860 TAG
3870 FOR I=-200 TO 200
3880 MOVE I,0
3890 PRINT CHR$(201);
3900 NEXT
3910 MOVE 200,0
3920 PRINT CHR$(32);
3930 MOVE -1,180
3940 PRINT"SATURN";
3950 TAGOFF
3960 PRINT
3970 PRINT
3980 PRINT
3990 PRINT USING"&###,##,##,##";"
SATURN IS MOST NOTABLE FOR I
T'S RINGS.THERE ARE SIX RINGS
.IT IS THE SECOND LARGES
T PLANET IN THE SOLAR SYSTEM.
THERE ARE 12 MOONS"
4000 PRINT:PRINT TAB(22);"PRESS SP
ACE TO CONTINUE....."
4010 M$=INKEY$
4020 IF M$=" " THEN 770
4030 GOTO 4010
4040 REM URANUS
4050 MODE 2:BORDER 0:INK 0,0:FOR K
=1 TO 150
4060 X=INT(RND*700)
4070 Z=INT(RND*500)
4080 PLOT X,Z
4090 PLOT Z,X
4100 NEXT
4110 FOR A=1 TO 360
4120 ORIGIN 320,200
4130 DRAW 80*COS(A),80*SIN(A)
4140 NEXT
4150 PRINT TAB(40);"URANUS"
4160 PRINT
4170 PRINT USING"&###,##,##,##";"U
RANUS WAS DISCOVERED IN 1781.
URANUS HAS 5 VERY FAINT RINGS
.IT ALSO HAS FIVE MOONS"
4180 PRINT:PRINT TAB(22);"PRESS SP
ACE TO CONTINUE....."
4190 M$=INKEY$
4200 IF M$=" " THEN 770
4210 GOTO 4190
4220 REM PLUTO
4230 INK 0,0:BORDER 0:MODE 2
4240 FOR P=1 TO 150
4250 Z=INT (RND*700)
4260 X=INT(RND*500)
4270 PLOT Z,X
4280 PLOT X,Z
4290 NEXT
4300 FOR A=1 TO 360
4310 ORIGIN 320,200
4320 DRAW 50*COS (A),50 *SIN(A)
4330 NEXT
4340 PRINT TAB(40);"PLUTO"

```

```

4350 PRINT USING "&###,##,##,##,##
";"PLUTO WAS DISCOVERED IN 19
30.IT HAS A FROZEN SURFACE AN
D IS THE COLDEST PLANET"
4360 PRINT:PRINT TAB(22);" PRESS S
PACE TO CONTINUE....."
4370 M$=INKEY$
4380 IF M$=" " THEN 770
4390 GOTO 4370
4400 REM LOST
4410 INK 0,0:CLS:MODE 1:FOR Q=1 TO
150
4420 Z=INT(RND*700)
4430 X=INT(RND*500)
4440 PLOT Z,X
4450 PLOT X,Z
4460 NEXT Q
4470 PRINT TAB(10);"YOU ARE DRIFTI
NG IN SPACE"
4480 FOR T=1 TO 1000:NEXT
4490 GOSUB 770
4500 REM QUIZ
4510 MODE 2:INK 0,0:BORDER 15:PRIN
T
4520 PRINT"YOU HAVE ARRIVED SAFELY
IN YOUR OWN TIME SPAN"
4530 PRINT" IT IS NOW TIME FOR YOU
R INITIATION INTO THE BROTHER
HOOD OF QUARKS.
4540 PRINT" THE TEST IS A TEST OF
KNOWLEDGE IN THE FORM OF A QU
IZ"
4550 PRINT CHR$(7)
4560 INPUT "ARE YOU READY";A$
4570 IF A$="YES" OR A$="yes" THEN
PRINT"HERE WE GO THEN":GOTO 4
590
4571 IF A$="NO" OR A$="no" THEN PR
INT" NO TIME TO BE SCARED BEC
AUSE HERE WE GO":GOTO 4590
4580 IF A$<>"YES" OR A$<>"yes" OR
A$<>"NO" OR A$<>"no" THEN PRI
NT"PLEASE TYPE YES OR NO":GOT
O 4550
4590 FOR T=1 TO 1000:NEXT
4600 CLS
4610 PRINT TAB(22);"PLEASE USE CAP
ITAL LETTERS"
4620 PRINT TAB(22);"PRESS ENTER AF
TER YOU HAVE TYPED IN YOUR AN
SWER"
4630 FOR T=1 TO 1000:NEXT
4640 PRINT
4650 C=0:W=0
4660 INPUT "WHAT IS THE CLOSEST PL
ANET TO THE SUN";A$
4670 IF A$="MERCURY" THEN GOSUB 51
30
4680 IF A$<>"MERCURY" THEN GOSUB 5
500
4690 INPUT "WHAT IS THE HOTTEST PL
ANET";A$
4700 IF A$="MERCURY" THEN GOSUB 51
30
4710 IF A$<>"MERCURY" THEN GOSUB 5
500
4720 INPUT "WHAT PLANET IS THE SAM
E SIZE AS PLANET EARTH";A$
4730 IF A$="VENUS" THEN GOSUB 5130
4740 IF A$<>"VENUS" THEN GOSUB 550
0
4750 INPUT "WHAT PLANET IS ALSO CA
LLED THE EVENING STAR";A$
4760 IF A$="VENUS" THEN GOSUB 5130
4770 IF A$<>"VENUS" THEN GOSUB 550
0
4780 INPUT "WHAT PLANET ROTATES BA
CKWARD";A$
4790 IF A$="VENUS" THEN GOSUB 5130
4800 IF A$<>"VENUS" THEN GOSUB 550
0
4810 INPUT "WHAT PLANET IS KNOWN A
S THE RED PLANET";A$
4820 IF A$="MARS" THEN GOSUB 5130
4830 IF A$<>"MARS" THEN GOSUB 5500
4840 INPUT "WHAT IS THE LARGEST PL
ANET";A$
4850 IF A$="JUPITER" THEN GOSUB 5
130
4860 IF A$<>"JUPITER" THEN GOSUB 5
500
4870 INPUT"WHAT PLANET HAS NO LIFE
FORMS ON IT" ;A$
4880 IF A$="MARS" THEN GOSUB 5130
4890 IF A$<>"MARS" THEN GOSUB 5500
4900 INPUT"HOW MANY MOONS DOES JUP
ITER HAVE";A
4910 IF A=13 THEN GOSUB 5130
4920 IF A<>13 THEN GOSUB 5500
4930 INPUT"WHAT PLANET HAS 6 RINGS
";A$
4940 IF A$="SATURN" THEN GOSUB 513
0
4950 IF A$<>"SATURN" THEN GOSUB 5
500
4960 INPUT "WHAT PLANET ONLY HAS 5
RINGS";A$

```

```

4970 IF A$="URANUS" THEN GOSUB 513
0
4980 IF A$<>"URANUS" THEN GOSUB 55
00
4990 INPUT "WHAT PLANET IS GREENIS
H IN COLOUR";A$
5000 IF A$="NEPTUNE" THEN GOSUB 51
30
5010 IF A$<>"NEPTUNE" THEN GOSUB 5
500
5020 INPUT "WHAT PLANET HAS 5 MOON
S";A$
5030 IF A$="URANUS" THEN GOSUB 513
0
5040 IF A$<>"URANUS" THEN GOSUB 55
00
5050 INPUT "WHAT IS THE SMALLEST P
LANET";A$
5060 IF A$="PLUTO" THEN GOSUB 5130
0
5070 IF A$<>"PLUTO" THEN GOSUB 550
0
5080 INPUT"WHAT PLANET IS THE ONLY
ONE TO HAVE LIFE FORMS";A$
5090 IF A$="EARTH" THEN GOSUB 5130
5100 IF A$<>"EARTH" THEN GOSUB 550
0
5110 GOSUB 5720
5120 REM RIGHT
5130 MODE 0
5140 INK 0,1
5150 PEN 13
5160 BORDER 10
5170 TAG
5180 MOVE 300,15
5190 PRINT CHR$(215);
5200 PRINT CHR$(214);
5210 MOVE 318,30
5220 PRINT CHR$(94);
5230 FOR T=1 TO 1000:NEXT
5240 FOR U=30 TO 300
5250 CALL &BD19
5260 MOVE 318,U
5270 PRINT CHR$(94);
5280 PRINT CHR$(32);
5290 NEXT
5300 ENV 1,1,18,0,11,0,10:ENT 1,10
,2,2
5310 SOUND 130,0,200,13,3,0,31
5320 MOVE 318,300
5330 PRINT CHR$(238);
5340 FOR T=1 TO 100:NEXT
5350 MOVE 318,300
5360 PRINT CHR$(32);
5370 FOR D=1 TO 100
5380 Z=INT(RND*700)
5390 X=INT(RND*500)
5400 PLOT Z,X
5410 PLOT X,Z
5420 NEXT
5430 MOVE 250,200
5440 PRINT"CORRECT";

```

```

5450 C=C+1
5460 FOR T=1 TO 1000:NEXT
5470 TAGOFF :MODE 2
5480 RETURN
5490 REM WRONG
5500 MODE 0
5510 INK 0,1:BORDER 9
5520 LOCATE 20,1
5530 FOR D=20 TO 1 STEP -1
5540 PRINT TAB(D);"/"
5550 NEXT
5560 LOCATE 1,1
5570 FOR P=1 TO 10
5580 PRINT TAB(P);"\ "
5590 NEXT
5600 FOR G=10 TO 20
5610 LOCATE G,G
5620 PRINT"\ "
5630 NEXT
5640 LOCATE 9,11
5650 PRINT"WRONG"
5660 SOUND 1,4095,100,15
5670 FOR T=1 TO 1000:NEXT
5680 W=W+1
5690 MODE 2
5700 RETURN
5710 REM SCORE+DO YOU WANT TO PLAY
AGAIN
5720 INK 0,1:BORDER 1
5730 MODE 2
5740 PRINT
5750 PRINT TAB(22);" YOU HAVE FINI
SHED THE TEST "
5760 PRINT TAB(22);" YOU HAVE ";C"
RIGHT"
5770 PRINT TAB(22);" AND YOU HAVE
";W "WRONG"
5780 PRINT
5790 IF C>10 THEN PRINT"YOU HAVE S
CORED HIGH ENOUGH TO BE ALLOW
ED INTO THE BROTHERHOOD OF QU
ARKS"
5800 IF C<10 THEN PRINT"YOU ARE NO
T SMART ENOUGH TO BELONG TO T
HE BROHTERHOOD OF QUARKS. I A
M SORRY"
5810 PRINT
5820 IF C<10 THEN PRINT"I THINK YO
U NEED TO DO ANOTHER EXPLORAT
ION OF THE EARTH SOLAR SYSTEM
"
5830 PRINT CHR$(7)
5840 INPUT "DO YOU WISH TO GO AGAI
N";A$
5850 IF A$="YES" OR A$="yes" THEN
760
5860 IF A$="NO" OR A$="no" THEN CA
LL 64738
5870 IF A$<>"YES" OR A$<>"yes" OR
A$<>"NO" OR A$<>"no" THEN PRI
NT"PLEASE TYPE YES OR NO":GOT
O 5830

```

Random Number Generation

by Arthur Harris

When you use your computer to generate random numbers you expect these numbers to be truly random. But are they?

The mathematical definition of a random number is that it should have the following properties:-

- (a) it must fall within the required range;
- (b) all numbers within the range must have an equal likelihood of occurring; and
- (c) its occurrence must not be predictable.

Another discussion, which appears to be equally valid, is that errors made during measurement can be of any size. Small errors are more likely than large errors. Consequently, to simulate experimental data with a random number generator, the numbers produced should NOT be equally likely. The only mathematical criterion that they must meet is that of unpredictability. The frequency distribution should be bell shaped, i.e. it should have a Normal or Gaussian distribution. This states that the values should be grouped around a particular figure, with those closest to this figure having a high probability and those further away having a lower probability.

Firstly, I will examine the conventional random number generators and methods of testing for randomness and then I will devote some time to Gaussian random numbers. A series of seven programs will be presented next month to demonstrate the generation and testing of random numbers.

WHY DON'T COMPUTERS GENERATE RANDOM NUMBERS?

The basic generator in your computer will generate numbers within a given range (condition (a) met). Because your computer works to a given order of accuracy, some numbers are excluded from the generation. If your computer produces numbers to 6 digits of accuracy, a number such as 99.33333 cannot be generated (condition (b) NOT met). Finally, your computer is deterministic; it only does as told, when told. Hence if you know the algorithm (the program steps) used to generate "random" numbers, you CAN predict what the next number will be. The algorithm may be complex, in which case it will involve a lot of work to produce the prediction, but the prediction will be accurate (condition (c) NOT met).

HOW RANDOM MUST RANDOM NUMBERS BE?

If the random numbers are to be used in games programs, it is not too critical how random the numbers are. A fairly crude generator will suffice. It is when the numbers are used for business simulations (including production simulation) that it is imperative that the random numbers be of the highest quality. But should they be mathematical or Gaussian random numbers? To fit the real life situation, I believe they should be Gaussian. The problem then becomes one of selecting the mean and standard deviation for the frequency distribution to be applied to the situation.

HOW ARE RANDOM NUMBERS GENERATED?

They are (possibly) five general methods of producing random numbers. These are the Additive Generator, the Congruential Generator, the Shift Register Generator, the Gaussian Generator and the Mid-Square Generator. Each one has its advantages and disadvantages.

The Mid-Square Generator

This method squares a seed number to produce a number larger than required and extracts the digits required from the middle of this number. For example, square a six digit number to get a 12 digit number and extract the required 6 digits from the middle. Use this current number to repeat the process. This type of program is simple to write in BASIC using STR\$, MID\$ and VAL functions. The resulting numbers appear to be random but do not stand up to mathematical testing.

The Additive Generator

Additive generators select two numbers and add them together. The result is constrained to lie within the required range by modulus arithmetic. This method is easy to program and generates apparently random numbers. The sequences repeat after a very short period. It appears that the longer runs occur when at least one of the seed numbers is a prime. Program Listing 1, when run on the Amstrad, generated either 192 or 384 numbers before producing the original pair in the same order. This was with a range of 0 to 256. Generally, it can be expected that run lengths will be short.

The Congruential Generator

(a) These generators are also known as

linear transformation algorithms. If the numbers are examined in the order produced, it will be found that a number is produced from the previous one by applying the formula:

$$X(N+1) = A * X(N) + B$$

where A and B are fixed numbers. This is the equation to a straight line, hence the name linear transformation. Program Listing 2 will demonstrate this type of generator and time the generation of N numbers. The seed is generated from the internal clock and the range is restricted to 0 to 256. Runs for this type of generator are generally much longer than for the Additive Generator.

(b) A modification to this occurs in the algorithm given in the Applications Manual for the HP-45 calculator. A is a prime number, X(1) is a nine-digit decimal fraction containing the digits 1 to 9 in "random" order and B is the integer part of the product A*X(N). This automatically constrains the result to lie between 0 and 1. Suitable scaling can then be applied. Program Listing 7 will demonstrate this algorithm. I generated 60 seeds (X(1)) and 60 factors (A) and placed them into an array. To select the seed and factor, I read the seconds from the internal clock, introduced a delay and read the seconds again. The first reading selects X(1) and the second selects A. These are then driven through the algorithm for the desired number of times. The delay (in line 60) appears to work as the same factor (A) appeared several times during a number of runs, but not always with the same seed (X(1)) each time. I have not included the DATA lines. This program is quite slow in its operation. Its main virtue is that using the somewhat random value for B improves an already good algorithm.

(c) The information about the Gaussian's random numbers comes from "BASIC Programs for Scientists and Engineers". The same book presents a random number generator which I assume is of the congruential type. The generation formula is:

$$X(N+1) = \text{EXP}(N * \text{LN}(X(N) + \text{PI}))$$

and then takes the decimal fraction part

of the resulting number as the random number.

This book seems to have a fixation on particular numbers without giving reasons for their use. For example they insist that 4 is the only value to use for X(1). They suggest 5.04 for N and also suggest that experimentation close to this figure may improve the result in some computers. They insist that the mean of a list of true random numbers should be 0.5 (agreed) and the standard deviation should be the reciprocal of the square root of 12, or 0.2887, to four decimal places (why?). Then they discuss the generation of runs of 48 random numbers only. They then choose to consider a sequence of 12 random numbers and manipulate them to produce Gaussian Random Numbers. I agree with the idea of a mean of 0.5 and presume, after some testing that shows that with long runs the standard deviation tends towards 0.2887, that this figure can be proved mathematically.

In manipulating the random numbers they take the sum of 12 of them (which should equal 6, ideally), subtract 6, multiply by the desired standard deviation and add the desired mean. This reduces to:

$$G = (RS - 6) * SD + M$$

where G is the Gaussian Random Number;

RS is the sum of 12 random numbers;

SD is the desired standard deviation; and

M is the desired mean.

The term (RS - 6) should give a series of values with the desired properties. Using SD and M merely scales the numbers to the desired range.

If this method of generating the basic random number is not congruential, then it represents the possible fifth method.

(4) The Shift Register Generator

This is the best of the methods of generation. No clear details are given and it is assumed that there are several variations on a common theme. In general, the algorithm consists of shifting the current number right or left

several times, XORing it and shifting the result left or right again. These actions take place at machine level in the microprocessor registers. The variations I have assumed would occur in the number of shifts applied and the number of times the basic algorithm is repeated before an answer is output.

I have assumed that the random number generator in the Amstrad is of this type, at this stage. Program Listing 6 will demonstrate this type of generator programmed in BASIC.

The best quality random numbers are produced by using a shift register algorithm to provide a seed for a congruential algorithm.

Next month I will present the methods of testing a random number generator and also give the program listings referred to this month, as well as some others.

**If you are
thoroughly
confused about
CP/M then you
must read next
month's
magazine.**

**We start a new
series designed
to help the
Amstrad user to
come to grips
with this
operating
system.**

Don't miss it!

BACK COPIES AVAILABLE

They are disappearing *FAST* - and we wont be printing anymore! If you've missed any copies order **NOW**.

	MAG	TAPE		MAG	TAPE
No. 1 - Feb(\$3.50)(\$5.00)	No. 7 - Aug(\$3.50)(\$5.00)
No. 2 - Mar(\$3.50)(\$5.00)	No. 8 - Sep(\$3.50)(\$5.00)
No. 3 - Apr(\$3.50)(\$5.00)	No. 9 - Oct(\$3.50)(\$5.00)
No. 4 - May(\$3.50)(\$5.00)	No. 10 - Nov(\$4.00)(\$5.00)
No. 5 - Jun(\$3.50)(\$5.00)	No. 11 - Dec(\$4.00)(\$5.00)
No. 6 - July(\$3.50)(\$5.00)			

The above prices include postage and packing

We also have a limited number of back copies of the English Amstrad User - probably the only stocks left in Australia - so plug the gaps in your collection before it's too late!

Jan/Feb	... \$4.00 incl. p & p	July	... \$4.50 incl. p & p
March	... \$4.00 incl. p & p	August	... \$4.50 incl. p & p
April	... \$4.00 incl. p & p	Sept	... \$4.50 incl. p & p
May	... \$4.00 incl. p & p	Oct	... \$4.50 incl. p & p
June	... \$4.00 incl. p & p	Nov	... \$4.50 incl. p & p

Note: We have just 6 copies of May, 3 of June, 30 of July, August and September and 60 of October. Keep your fingers crossed that we can get some more!

Please send your order and remittance to:

Strategy Publications,
 2/33 The Centreway, Blackburn Road
 Mt. Waverley, Victoria 3149 Tel: (03) 232 7055
 (Bankcard and MasterCard accepted)

BACK COPIES AVAILABLE

The 40cent Programs

by Ivor Joystick

Once upon a time, a sensible man bought an Amstrad computer.

Thirsting for information, he took out a subscription to The Amstrad User, the largest selling magazine for the Amstrad range in Australia.

He didn't need his machine to work out that, for less than \$3* per month for 32 pages (and quite often more) of solid Amstrad information, he was getting programs for less than 40 cents each!

This made him live very happily ever after.

... but that's not the end of the story

Every month The Amstrad User is packed with a range of articles, programs, hardware and software reviews, utilities, User Group Information, Letters, Tutorials, Hints and Tips - all devoted entirely to the Amstrad computers.

And to save you the trouble of keying-in and correcting your typing errors, a cassette containing the programs appearing in the magazine each month is also available.

Make your Amstrad a success story by subscribing to The Amstrad User now.

* Based on yearly subscription of \$35.

Please send me THE AMSTRAD USER for 12 months

Magazine only: \$35 Magazine and cassette: \$75 (PNG and NZ add \$12 airmail)

Payment by: Cheque Bankcard or Mastercard

Card number _____ Expiry date.....

Name Phone.....

Address

..... Postcode

Signed **Please start with Issue No.....**

Return to THE AMSTRAD USER, Shop 2, 33-45 The Centreway,
Blackburn Road, Mt. Waverley, Vic 3149 Tel 03-232 7055

(OVERSEAS PRICES ON APPLICATION TO ABOVE ADDRESS)